

HMIC™ Silicon SP4T PIN Diode Switch with Integrated Bias Network

Rev. V4

Features

- Broad Bandwidth Specified up to 18 GHz
- Usable up to 26 GHz
- Integrated Bias Network
- Low Insertion Loss / High Isolation
- Fully Monolithic, Glass Encapsulated Chip
- RoHS* Compliant

Description

The MA4SW410B-1 device is a SP4T broadband switch with integrated bias network utilizing MACOM's HMIC™ (Heterolithic Microwave Integrated Circuit) process, US Patent 5,268,310. This process allows the incorporation of silicon pedestals that form series and shunt diodes or vias by imbedding them in low loss, low dispersion glass. By using small spacing between elements, this combination of silicon and glass gives HMIC devices low loss and high isolation performance with exceptional repeatability through low millimeter frequencies. Large bond pads facilitate the use of low inductance ribbon bonds, while gold backside metallization allows for manual or automatic chip bonding via 80/20 - Au/Sn, 62/36/2 - Sn/Pb/Ag solders or electrically conductive silver epoxy.

These high performance switches are suitable for use in multi-band ECM, Radar, and instrumentation control circuits where high isolation to insertion loss ratios are required. With a standard +5 V / -5 V, TTL controlled PIN diode driver, 80 ns switching speeds can be achieved.

Ordering Information

Part Number	Package
MA4SW410B-1	Gel Pack

Functional Diagrams

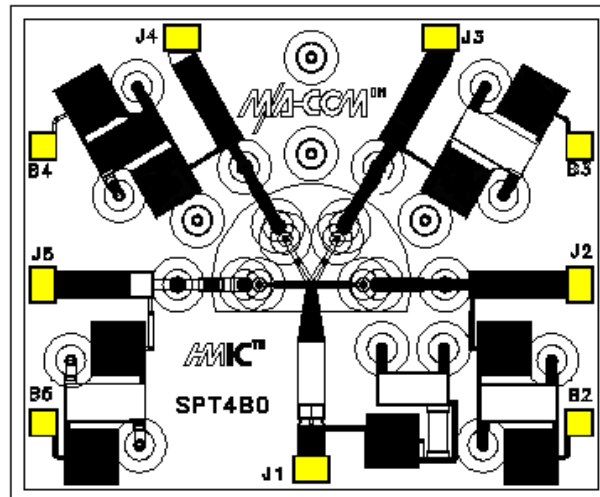

Yellow areas denote wire bond pads

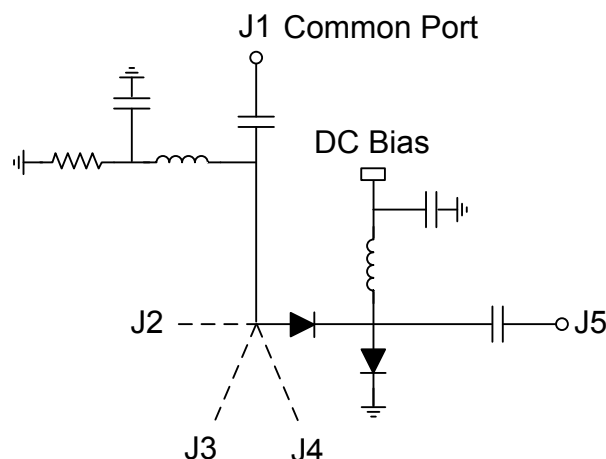

*Restrictions on Hazardous Substances, European Union Directive 2011/65/EU.

Electrical Specifications: $T_A = +25^\circ\text{C}$, 10 mA (On-Wafer Measurements)

Parameter	Test Conditions	Units	Min.	Typ.	Max.
Insertion Loss	6 GHz	dB	—	0.8	1.0
	12 GHz			1.0	1.2
	18 GHz			1.4	1.6
Isolation	6 GHz	dB	40	50	—
	12 GHz		35	40	
	18 GHz		30	35	
Input Return Loss	6 GHz	dB	—	10	—
	12 GHz			15	
	18 GHz			10	
Switching Speed ¹	10 GHz	ns	—	80	—

1. Typical switching speed is measured from (10% to 90% and 90% to 10% of detected RF voltage), driven by TTL compatible drivers. In the modulating state, (the switching port is modulating, all other ports are in steady state isolation.) The switching speed is measured using an RC network using the following values: R = 50 - 200 Ω , C = 390 - 1000 pF. Driver spike current, $I_C = C dv/dt$, ratio of spike current to steady state current, is typically 10:1.

Absolute Maximum Ratings^{2,3,4}

Parameter	Absolute Maximum
RF CW Incident Power	+33 dBm
Reverse Voltage	-25 V
Bias Current per Port	± 50 mA @ $+25^\circ\text{C}$
Junction Temperature	$+175^\circ\text{C}$
Operating Temperature	-65°C to $+125^\circ\text{C}$
Storage Temperature	-65°C to $+150^\circ\text{C}$

- Exceeding any one or combination of these limits may cause permanent damage to this device.
- MACOM does not recommend sustained operation near these survivability limits.
- Maximum operating conditions for a combination of RF power, DC bias and temperature: +33 dBm CW @ 15 mA (per diode) @ $+85^\circ\text{C}$.

Handling Procedures

Please observe the following precautions to avoid damage:

Static Sensitivity

These electronic devices are sensitive to electrostatic discharge (ESD) and can be damaged by static electricity. Proper ESD control techniques should be used when handling these Class 0 (HBM) and Class C1 (CDM) devices.

Typical RF Performance @ $T_{AMB} = +25^{\circ}\text{C}$ (Probed on Wafer)

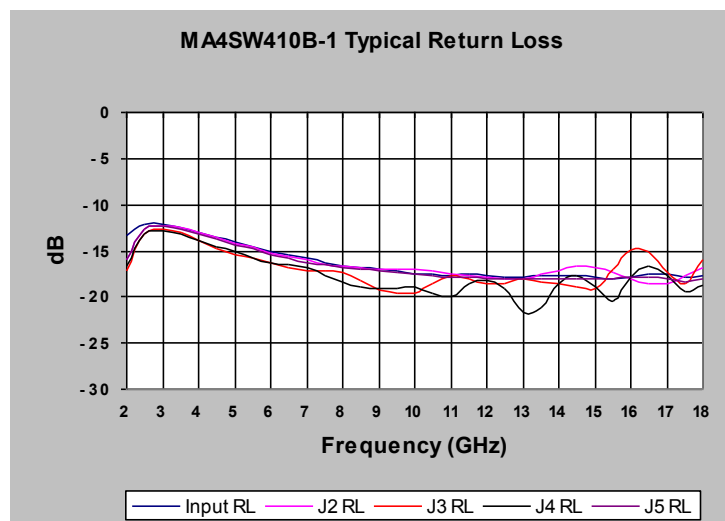
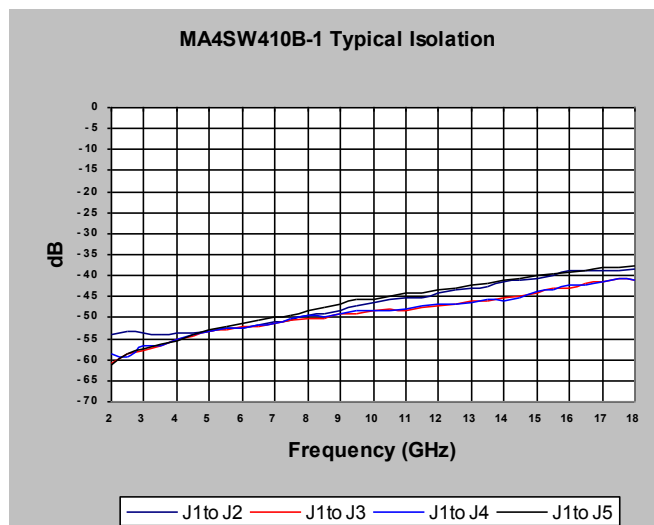
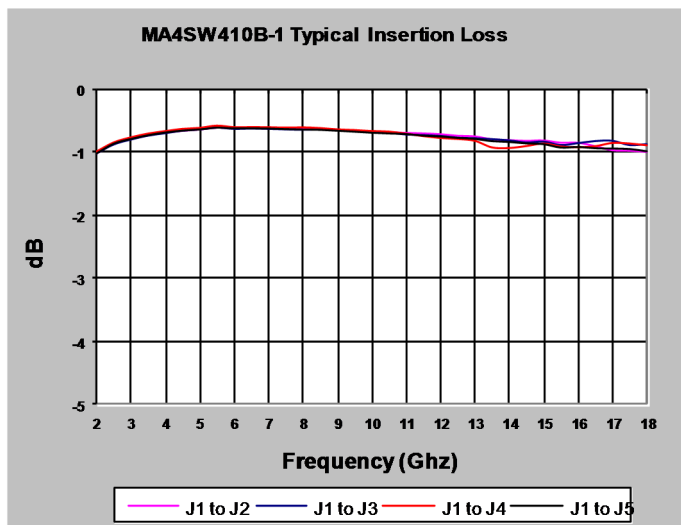

Operation of the MA4SW410B-1 PIN Switch

Operation of the HMIC Series of PIN switches is achieved by the simultaneous application of negative DC current to the low loss port and positive DC current to the remaining isolated switching ports per the Driver Connections table below. The control currents should be supplied by constant current sources. For insertion loss, -10 mA bias results in approximately -2 V, and for Isolation, +10 mA yields approximately +0.9 V at the respective bias nodes. The backside area of the die is the RF and DC return ground plane.

Typical Bias Network

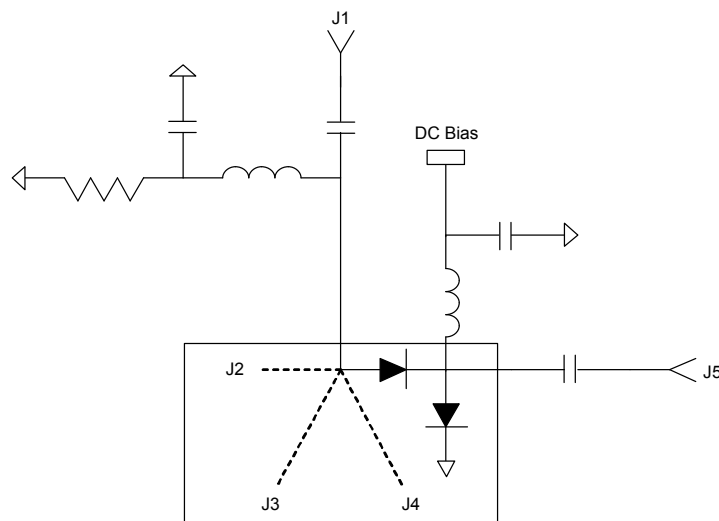

Typical Driver Connections

DC Control Current (mA)				RF Output States			
B2	B3	B4	B5	J1-J2	J1-J3	J1-J4	J1-J5
-10	+10	+10	+10	low loss	Isolation	Isolation	Isolation
+10	-10	+10	+10	Isolation	low loss	Isolation	Isolation
+10	+10	-10	+10	Isolation	Isolation	low loss	Isolation
+10	+10	+10	-10	Isolation	Isolation	Isolation	low loss

Chip Dimensions^{5,6}

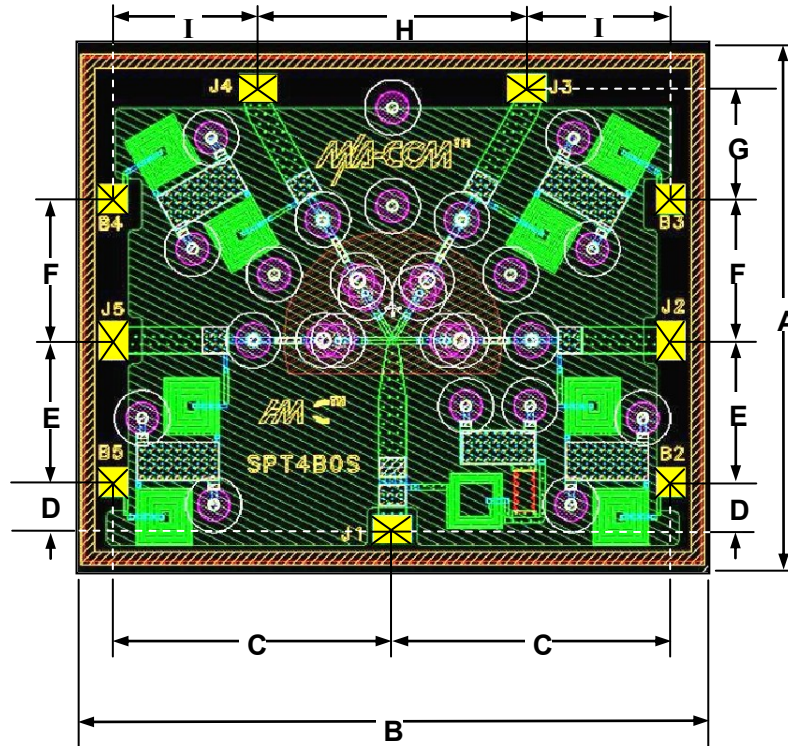

5. Topside and backside metallization is gold, 2.5 μm thick typical.
6. Yellow areas indicate wire bonding pads.

DIM	Mils		Millimeters	
	Min.	Max.	Min.	Max.
A	86.0	90.0	2.18	2.29
B	106.0	110.0	2.69	2.79
C	49.5	50.5	1.26	1.28
D	8.0	9.0	0.20	0.23
E	25.0	26.0	0.64	0.66
F	25.0	26.0	0.64	0.66
G	19.0	20.0	0.48	0.51
H	47.5	48.5	1.21	1.23
I	25.5	26.5	0.65	0.67
RF Bond Pads (J1 - J5)	7.0 x 5.0 ref.		0.178 x 0.127 ref.	
DC Bond Pads (B2 - B5)	5.0 x 5.0 ref.		0.127 x 0.127 ref.	
Chip Thickness	5.0 ref.		0.127 ref.	