

Features

- Saturated Power: 30.5 dBm Typical
- Gain: 19 dB Typical
- Power Added Efficiency: 30%
- DC Decoupled RF Input and Output
- Lead-Free 7-Lead Ceramic Package
- RoHS* Compliant and 260°C Reflow Compatible

Description

The MAAM26100-B1 is a GaAs MMIC two stage high efficiency power amplifier in a small, lead-free, 7-lead ceramic package. The MAAM26100-B1 is a fully monolithic design which eliminates the need for external circuitry in 50-ohm systems.

The MAAM26100-B1 is ideally suited for driver amplifiers and transmitter outputs in UMTS applications, test equipment, electronic warfare jammers, missile subsystems and phased array radars.

The MAAM26100-B1 is fabricated using a mature 0.5-micron gate length GaAs process. The process features full passivation for increased performance reliability.

Absolute Maximum Ratings ^{1,2}

Parameter	Absolute Maximum
V_{DD}	+9 V
V_{GG}	-6 V to -3 V
RF Input Power	+17 dBm
Channel Temperature	150°C
Storage Temperature	-65°C to +150°C

1. Exceeding any one or combination of these limits may cause permanent damage to this device and will void product warranty.
2. M/A-COM Tech does not recommend sustained operation near these survivability limits.

Functional Diagram ^{3,4}

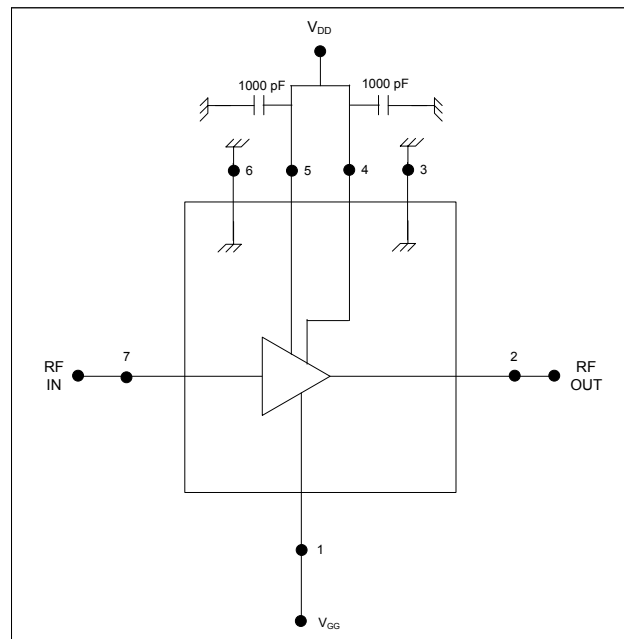

3. Nominal bias is obtained by first connecting -5 volts to pin 1 (V_{GG}), followed by connecting +8 volts to pin 5 (V_{D1}) and pin 4 (V_{D2}). Note sequence.
4. RF ground and thermal interface are the case bottom. Adequate heat sinking is required.

Pin Configuration

Pin No.	Function	Pin No.	Function
1	V_{GG}	5	V_{D1}
2	RF Output	6	Internal Ground
3	Internal Ground	7	RF Input
4	V_{D2}		

Ordering Information

Part Number	Package
MAAM26100-B1	7 lead, Ceramic (CR-2)
MAAM26100-B1G	7 lead, Ceramic (CR-2) with Gull Wing

* Restrictions on Hazardous Substances, European Union Directive 2002/95/EC.

GaAs MMIC Power Amplifier 2 - 6 GHz

Rev. V7

Electrical Specifications: $T_A = 25^\circ\text{C}$, $V_{DD} = +8\text{ V}$, $V_{GG} = -5\text{ V}$, $Z_0 = 50\ \Omega$

Parameter	Test Conditions	Units	Min.	Typ.	Max.
Small Signal Gain	2 - 6 GHz	dB	15	19	—
Input VSWR	Input Power +14 dBm, 2 - 6 GHz	Ratio	—	1.7:1	2.1:1
Output VSWR	Input Power +14 dBm, 2 - 6 GHz	Ratio	—	2.2:1	—
Saturated Output Power	Input Power +14 dBm, 2 - 6 GHz	dBm	29	30.5	—
Output Power at 1 dB Gain Compression	2 - 6 GHz	dBm	—	27	—
Power Added Efficiency	—	%	—	30	—
Third Order Intercept	2 - 6 GHz	dBm	—	39	—
Reverse Isolation	2 - 6 GHz	dB	—	30	—
I_{DSQ}	No RF	mA	—	390	—
I_{DS}	Input Power +14 dBm	mA	300	475	650
I_{GG}	Input Power +14 dBm	mA	—	10	—
Thermal Resistance ⁵	—	$^\circ\text{C/W}$	—	16.5	—

5. Attachment method not included.

Lead-Free CR-2[†]

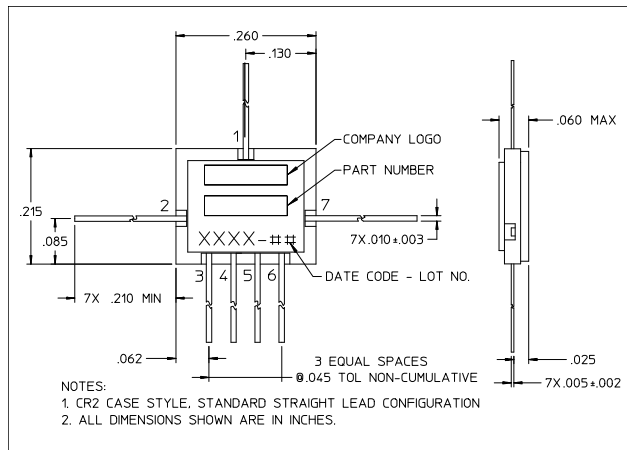

Lead-Free CR-2 w/ Gull Wing [†]

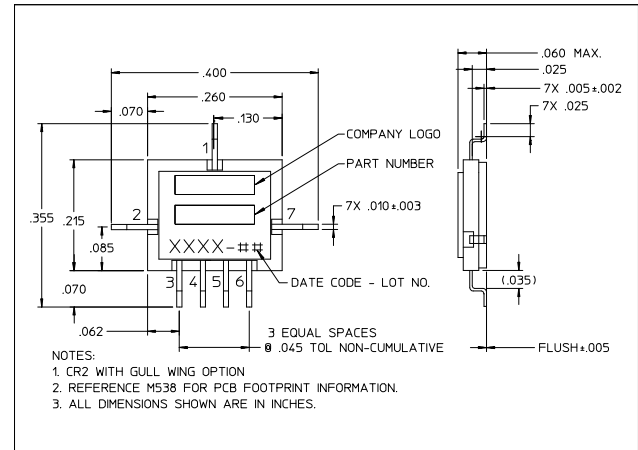

[†] Reference Application Note M538 for lead-free solder reflow recommendations.
Meets JEDEC moisture sensitivity level 1 requirements.