

## Low Noise GaAs MMIC Amplifier 3.5 - 7.0 GHz

Rev. V8

### Features

- Low Noise Figure: 2.2 dB Typical
- High Gain: 17 dB Typical
- Gain Flatness:  $\pm 0.5$  dB
- Single Supply: +4 V
- No External Components Required
- DC Decoupled RF Input and Output
- Lead-Free 8-Lead Ceramic Package
- RoHS\* Compliant and 260°C Reflow Compatible

### Description

The MAAM37000-A1 is a wide-band, low noise, MMIC amplifier housed in a small, lead-free, 8-lead ceramic package. It includes two integrated gain stages and employs series inductive feedback to obtain excellent noise figure and a good, 50  $\Omega$ , input and output impedance match over the entire frequency band. The MAAM37000-A1 operates from a single +4 V supply. It is fully monolithic, requires no external components, and is provided in a user-friendly, microwave package.

The MAAM37000-A1 performs well as a low noise amplifier in receive applications and as a driver or buffer amplifier where high gain, excellent linearity and low power consumption are important. Because of its wide bandwidth, the MAAM37000-A1 can be used in numerous commercial and government system applications, such as TVRO, VSAT, missile guidance and radar.

The MAAM37000-A1 is manufactured in-house using a reliable, 0.5-micron, GaAs MESFET process. This product is 100% RF tested to ensure compliance to performance specifications.

### Ordering Information

Part Number	Package
MAAM37000-A1	8-lead Ceramic (CR-3)
MAAM37000-A1G	Gull Wing (CR-10)

### Functional Schematic

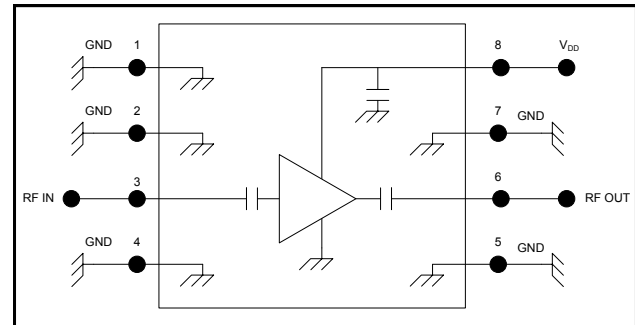

### Pin Configuration<sup>1</sup>

Pin No.	Function	Pin No.	Function
1	Ground	5	Ground
2	Ground	6	RF Output
3	RF Input	7	Ground
4	Ground	8	V <sub>DD</sub>

1. The package bottom must be connected to RF and DC ground.

### Absolute Maximum Ratings<sup>2,3</sup>

Parameter	Absolute Maximum
V <sub>DD</sub>	+7 V
Input Power	+20 dBm
Current	150 mA
Channel Temperature	+150°C
Operating Temperature <sup>4</sup>	-55°C to +100°C
Storage Temperature	-65°C to +150°C

2. Exceeding any one or combination of these limits may cause permanent damage to this device.
3. M/A-COM Technology does not recommend sustained operation near these survivability limits.
4. Typical thermal resistance ( $\theta_{jc}$ ) = +120°C/W

\* Restrictions on Hazardous Substances, European Union Directive 2002/95/EC.

## Lead-Free CR-10 (MAAM37000-A1G)<sup>†</sup>

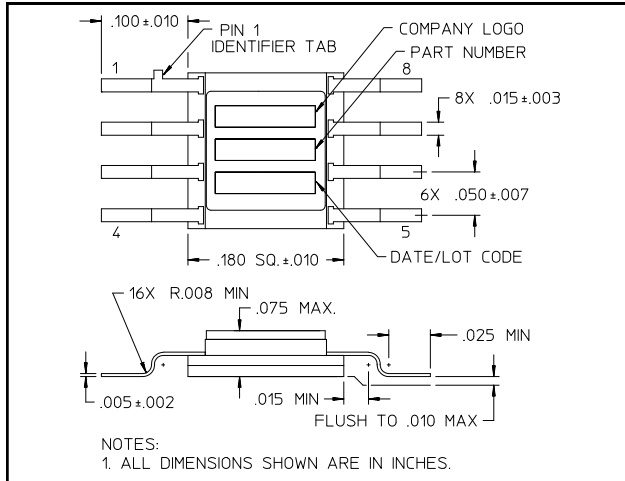

## Lead-Free CR-3 (MAAM37000-A1)<sup>†</sup>

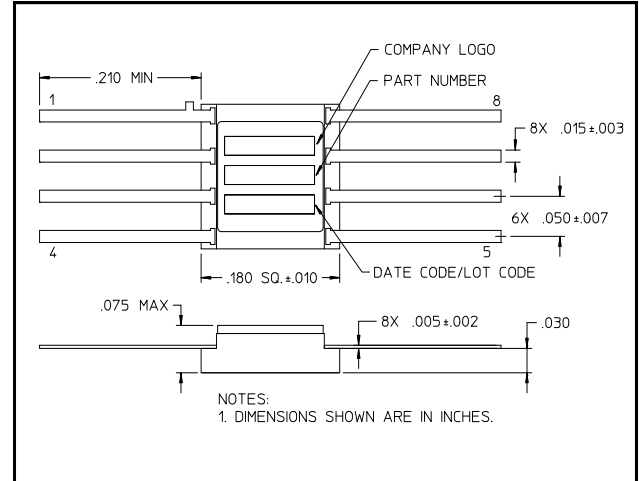

<sup>†</sup> Reference Application Note M538 for lead-free solder reflow recommendations.  
 Meets JEDEC moisture sensitivity level 1 requirements.

## Electrical Specifications: $T_A = 25^\circ\text{C}$ , $V_{DD} = +4\text{ V}$ , $Z_0 = 50\ \Omega$

Parameter	Test Conditions	Units	Min.	Typ.	Max.
Gain	3.5 - 7.0 GHz, $P_{IN} = -30\text{ dBm}$	dB	15	17	—
Noise Figure	3.5 - 7.0 GHz	dB	—	2.2	3.2
Input VSWR	3.5 - 7.0 GHz, $P_{IN} = -30\text{ dBm}$	Ratio	—	2.0:1	—
Output VSWR	3.5 - 7.0 GHz, $P_{IN} = -30\text{ dBm}$	Ratio	—	2.0:1	—
Output 1 dB Compression	3.5 - 7.0 GHz	dBm	—	+14	—
Input IP3	3.5 - 7.0 GHz, $P_{IN} = -30\text{ dBm}$	dBm	—	+8	—
Reverse Isolation	3.5 - 7.0 GHz, $P_{IN} = -30\text{ dBm}$	dB	—	35	—
Bias Current	—	mA	—	75	110

## Typical Performance @ +25°C

Gain

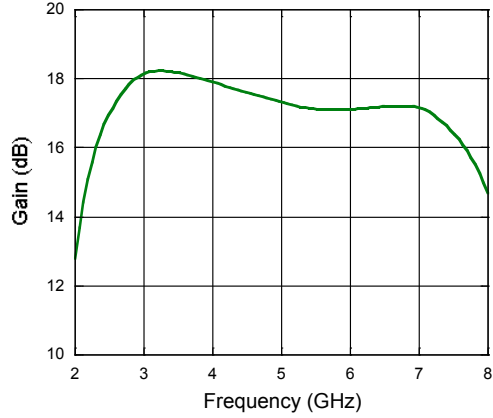

VSWR

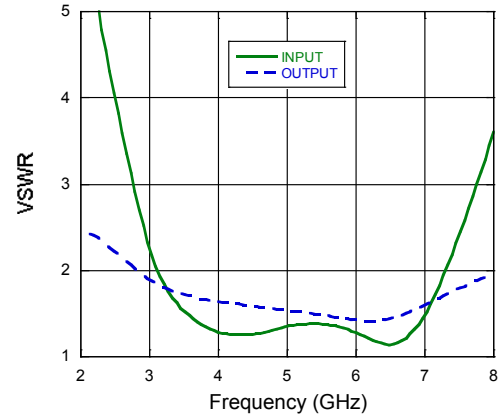

Noise Figure

