

## Digital Attenuator 30 dB, 4-Bit, TTL Driver, DC - 3 GHz

Rev. V5

### Features

- Attenuation: 2 dB Steps to 30 dB
- Low DC Power Consumption
- Integral TTL Driver
- 50  $\Omega$  Impedance
- Temperature Stability:  
±0.18 dB from -55°C to +85°C
- Lead-Free SO-16 Package
- 100% Matte Tin Plating over Copper
- Halogen-Free “Green” Mold Compound
- 260°C Reflow Compatible
- RoHS\* Compliant Version of AT65-0233

### Description

The MAATCC0006 is a GaAs FET 4-bit digital attenuator with a 2 dB minimum step size and a 30 dB total attenuation range. This device is in a SOIC-16 plastic surface mount package.

The MAATCC0006 is ideally suited for use where accuracy, fast speed, very low power consumption is required. Typical applications include dynamic range setting in precision receiver circuits and other gain/leveling control circuits.

### Ordering Information<sup>1</sup>

Part Number	Package
MAATCC0006	Bulk Packaging
MAATCC0006TR	1000 piece reel
MAATCC0006-TB	Sample Test Board

1. Reference Application Note M513 for reel size information.

### Schematic with Off-Chip Components or Functional Block Diagram

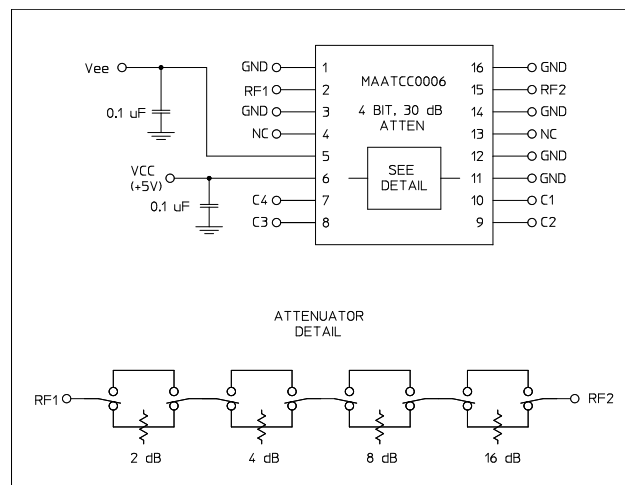

### Pin Configuration

Pin #	Function	Pin #	Function
1	GND	9	C2
2	RF1	10	C1
3	GND	11	GND
4	NC <sup>2</sup>	12	GND
5	Vee	13	NC <sup>2</sup>
6	Vcc	14	GND
7	C4	15	RF2
8	C3	16	GND

2. NC = No Connection

\* Restrictions on Hazardous Substances, compliant to current RoHS EU directive.

## Digital Attenuator 30 dB, 4-Bit, TTL Driver, DC - 3 GHz

Rev. V5

### Electrical Specifications: $T_A = 25^\circ\text{C}$

Parameter	Test Conditions	Units	Min.	Typ.	Max.
Insertion Loss	DC - 0.5 GHz	dB	—	1.7	2.0
	DC - 2.0 GHz			2.3	2.7
	DC - 3.0 GHz			2.6	3.1
Attenuation Accuracy	Any Bit or Combination of Bits DC - 3.0 GHz	dB	± (.4 + 8% of attenuation)		
VSWR	Full Range DC - 3.0 GHz	Ratio	—	—	1.7:1
Trise, Tfall Ton, Toff Transients	10% to 90%	ns	—	10	50
	50% Cntl to 90%/10% RF	ns		30	150
	In-Band	mV		35	—
1 dB Compression	Input Power 0.05 GHz 0.5 - 3.0 GHz	dBm	—	+20 +28	—
Input $IP_3$	Two-tone inputs up to +5 dBm 0.05 GHz 0.5 - 3.0 GHz	dBm	—	+40 +50	—
Input $IP_2$	Two-tone inputs up to +5 dBm 0.05 GHz 0.5 - 3.0 GHz	dBm	—	+45 +68	—
VCC	—	V	4.5	5.0	5.5
VEE	—	V	-8.0	-5.0	-4.75
$V_{IL}$	LOW-level input voltage HIGH-level input voltage	V	0.0	—	0.8
$V_{IH}$			2.0		5.0
$I_{in}$ (Input Leakage Current)	$V_{in} = V_{CC}$ or GND	$\mu\text{A}$	-1.0	—	1.0
$I_{cc}$ (Quiescent Supply Current)	$V_{cntrl} = V_{CC}$ or GND	$\mu\text{A}$	—	250	400
$\Delta I_{cc}$ (Additional Supply Current Per TTL Input Pin)	$V_{CC} = \text{Max}$ , $V_{cntrl} = V_{CC} - 2.1 \text{ V}$	mA	—	—	1.0
IEE	VEE min to max, $V_{in} = V_{IL}$ or $V_{IH}$	mA	-1.0	-0.2	—

### Absolute Maximum Ratings<sup>3,4</sup>

Parameter	Absolute Maximum
Input Power 0.05 GHz 0.5 - 3.0 GHz	+27 dBm +34 dBm
$V_{CC}$	$-0.5 \text{ V} \leq V_{CC} \leq +7.0 \text{ V}$
$V_{EE}$	$-8.5 \text{ V} \leq V_{EE} \leq +0.5 \text{ V}$
$V_{CC} - V_{EE}$	$-0.5 \text{ V} \leq V_{CC} - V_{EE} \leq 14.5 \text{ V}$
$V_{in}^5$	$-0.5 \text{ V} \leq V_{IN} \leq V_{CC} + 0.5 \text{ V}$
Operating Temperature	-40°C to +85°C
Storage Temperature	-65°C to +125°C

- Exceeding any one or combination of these limits may cause permanent damage to this device.
- MACOM does not recommend sustained operation near these survivability limits.
- Standard CMOS TTL interface, latch-up will occur if logic signal applied prior to power supply.

### Truth Table (Digital Attenuator)<sup>6</sup>

C1	C2	C3	C4	Attenuation
0	0	0	0	Loss, Reference
1	0	0	0	2.0 dB
0	1	0	0	4.0 dB
0	0	1	0	8.0 dB
0	0	0	1	16.0 dB
1	1	1	1	30.0 dB

6. 0 = TTL Low; 1 = TTL High

## Typical Performance Curves

**Typical Insertion Loss (dB)**

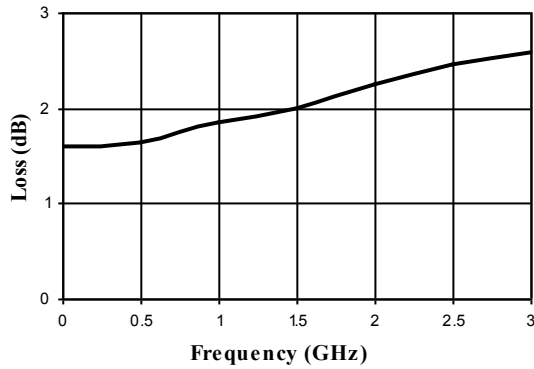

**Attenuation Accuracy, 2 dB**

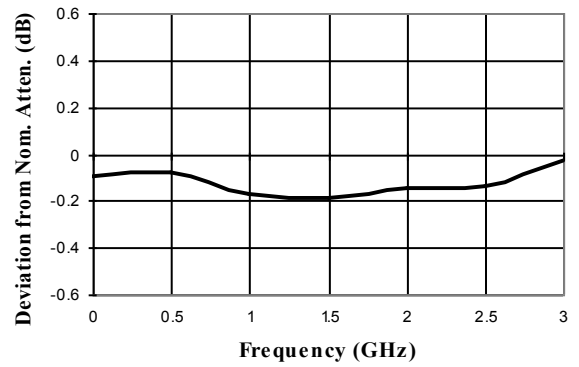

**Attenuation Accuracy, 4 dB**

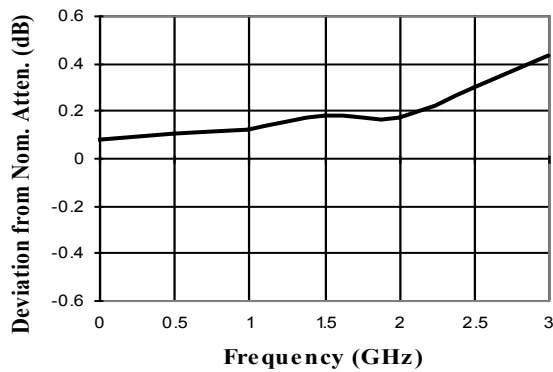

**Attenuation Accuracy, 8 dB**

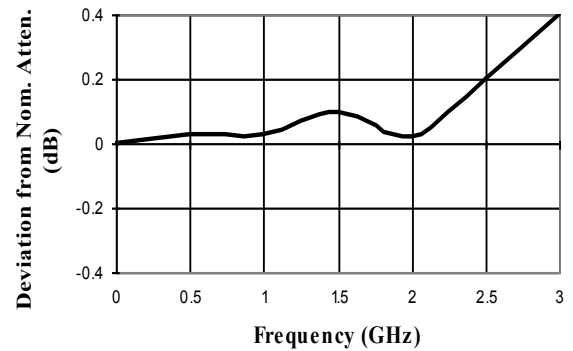

## Typical Performance Curves

**Attenuation Accuracy, 16 dB**

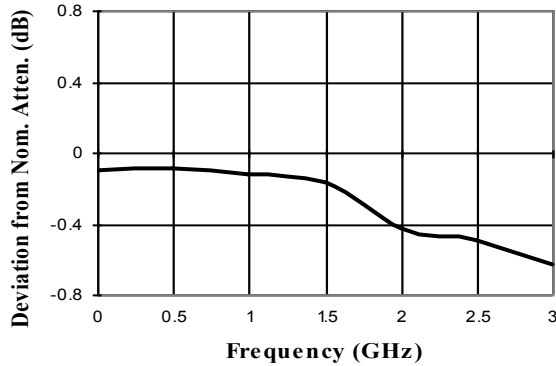

**Attenuation Accuracy, 30 dB**

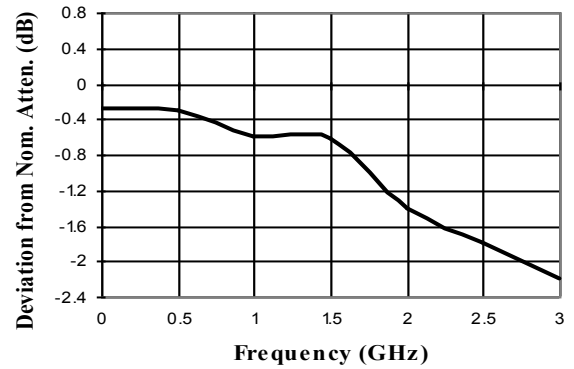

**Typical RF1 VSWR**

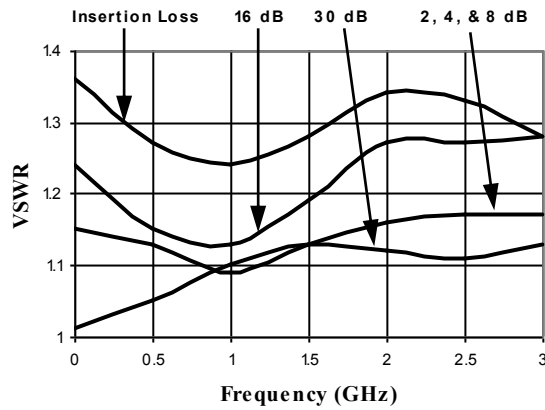

**Typical RF2 VSWR**

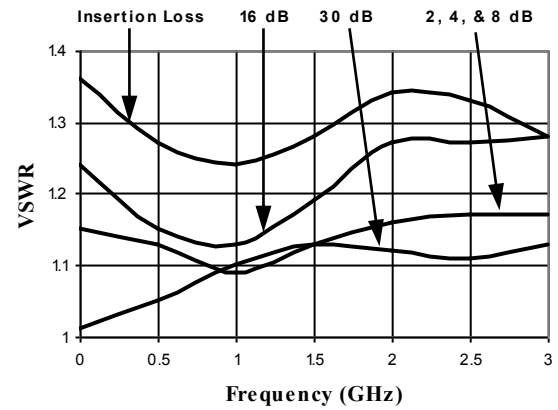

## Digital Attenuator 30 dB, 4-Bit, TTL Driver, DC - 3 GHz

Rev. V5

### Handling Procedures

Please observe the following precautions to avoid damage:

### Static Sensitivity

Gallium Arsenide Integrated Circuits are sensitive to electrostatic discharge (ESD) and can be damaged by static electricity. Proper ESD control techniques should be used when handling these devices.

### Lead-Free, SOIC-16<sup>†</sup>

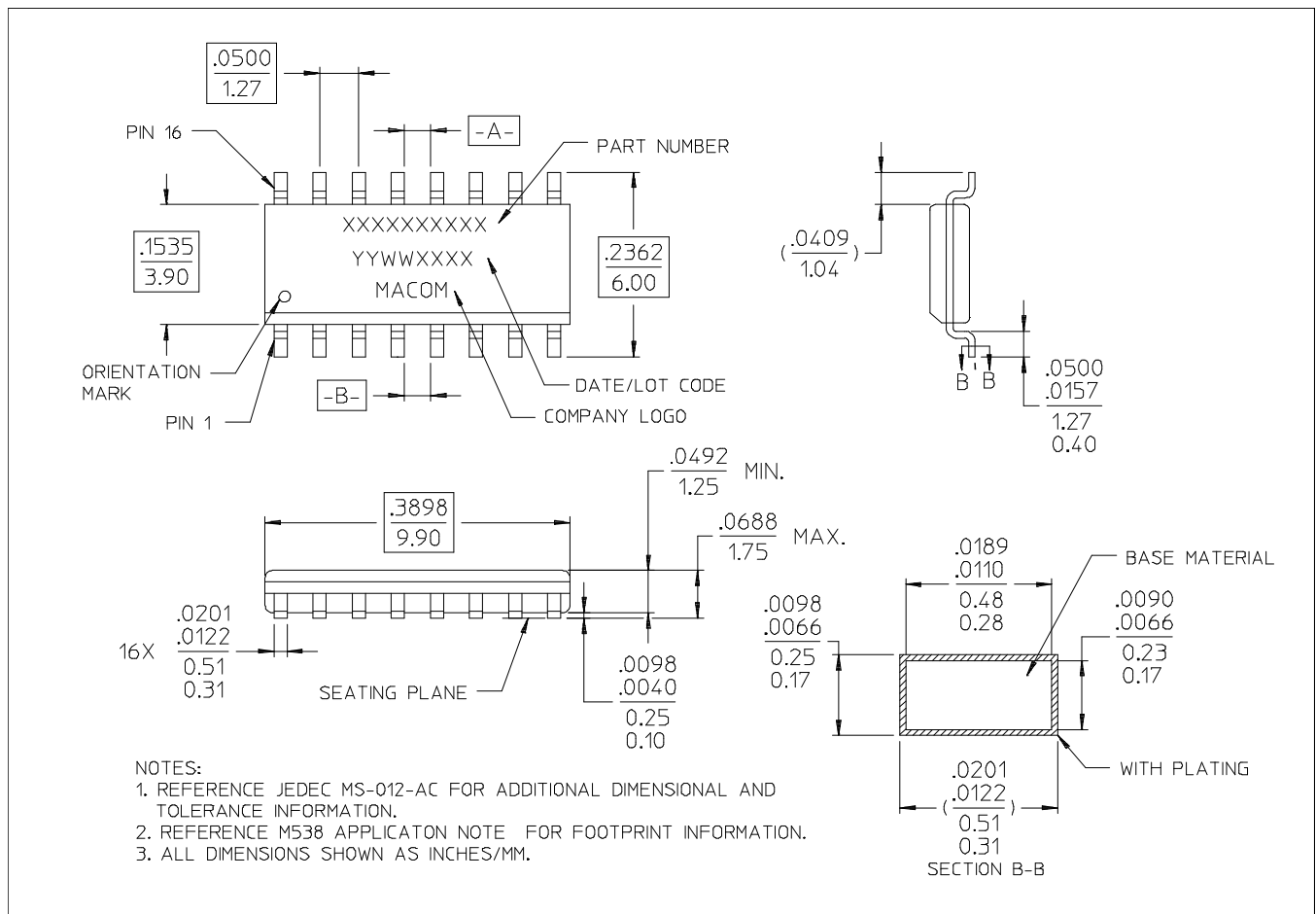

<sup>†</sup> Reference Application Note M538 for lead-free solder reflow recommendations.