

**1:1 Flux Coupled Balun Transformer**  
**5 - 300 MHz**

Rev. V7

## Features

- 1:1 impedance
- Surface mount
- Available on tape and reel
- 260° reflow compatible
- RoHS Compliant and Pb free
- Excellent temperature stability
- Suitable for all CATV, Broadband and FTTX applications

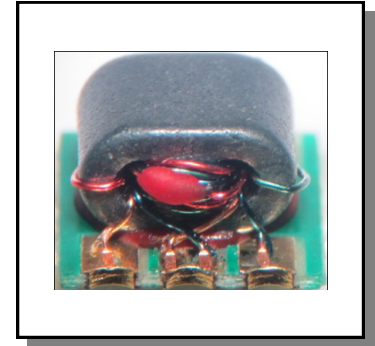

## Description

MACOM's MABA-009852-CF1A40 is a 1:1 Flux coupled transformer. This Transformer is ideally suited for CATV and Broadband applications.

## Functional Schematic

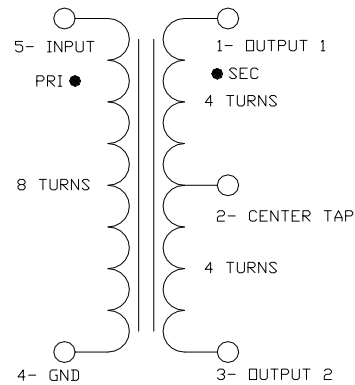

## Ordering Information

Part Number	Description
MABA-009852-CF1A40	Tape & Reel
MABA-009852-CF1ATB	Customer Test Board

## Pin Configuration

Function	Pin Number
Secondary Dot (Output 1)	1
Secondary Centre Tap	2
Secondary (Output 2)	3
Primary (Ground)	4
Primary Dot (Input)	5

## 1:1 Flux Coupled Balun Transformer 5 - 300 MHz

Rev. V7

Electrical Specifications:  $T_A = 25^\circ\text{C}$ , 0dBm,  $Z_0 = 75\Omega$

Parameter	Test Conditions	Units	Min.	Typ.	Max.
Frequency Range		MHz	5		300
Insertion Loss 1 (Pin 5 - Pin 1)	5 – 75 MHz	dB	–	0.1	0.4
	75 – 120 MHz	dB	–	0.3	0.6
	120 – 204 MHz	dB	–	0.63	0.8
	204 – 300 MHz	dB	–	1.0	1.2
Insertion Loss 2 (Pin 5 - Pin 3)	5 – 75 MHz	dB	–	0.26	0.4
	75 – 120 MHz	dB	–	0.30	0.5
	120 – 204 MHz	dB	–	0.31	0.6
	204 – 300 MHz	dB	–	0.32	0.6
Amplitude Balance	5 – 75 MHz	dB	–	0.03	0.17
	75 – 120 MHz	dB	–	0.12	0.38
	120 – 204 MHz	dB	–	0.30	0.50
	204 – 300 MHz	dB	–	0.70	1.00
Phase Balance (Nominal phase difference is 180 degrees)	5 – 75 MHz	°	–	0.05	2.0
	75 – 120 MHz	°	–	0.10	3.0
	120 – 204 MHz	°	–	1.53	3.9
	204 – 300 MHz	°	–	3.0	6.1
Input Return Loss (Pin 5)	5 – 20 MHz	dB	25	30	–
	20 – 75 MHz	dB	20	28	–
	75 – 120 MHz	dB	15	19	–
	120 – 204 MHz	dB	15	20	–
	204 – 300 MHz	dB	12	17	–

### Recommended Maximum Ratings

Parameter	Units	Min	Max
Input Power	W		0.5
DC Current	mA		500
Operating Temperature Range	°C	-40	+100

Full temperature plots available on request

## Outline Drawing

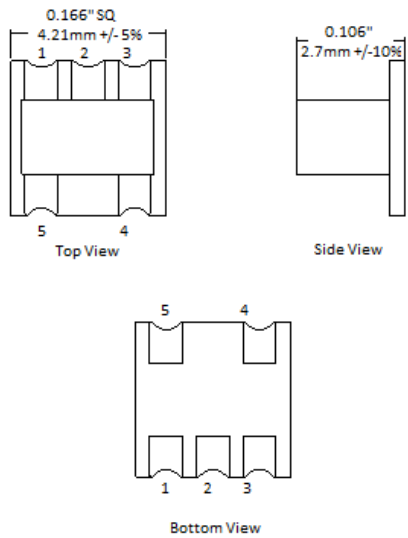

## PCB Layout

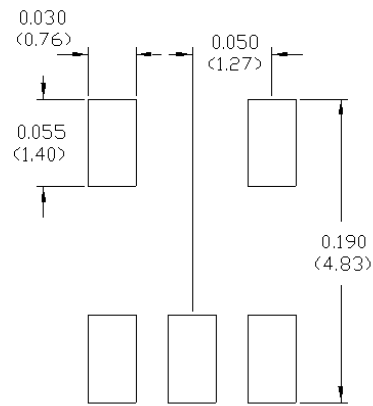

1. Dimensions in mm.
2. Tolerance:  $\pm 0.2$ mm unless otherwise noted.
3. Model number and lot code are printed on the reel.
4. Lead plating: ENIG.

## Tape & Reel Information

Parameter	Units	Value
Qty per reel	-	2000
Reel Size	mm	330
Tape Width	mm	12.00
Pitch	mm	8.00
Ao	mm	4.50
Bo	mm	4.50
Ko	mm	2.73
Orientation	-	F31
Reference Application Note ANI-019 for orientation		

## Application Circuit

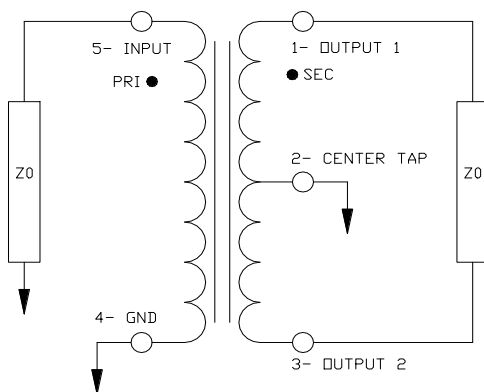

## 1:1 Flux Coupled Balun Transformer 5 - 300 MHz

Rev. V7

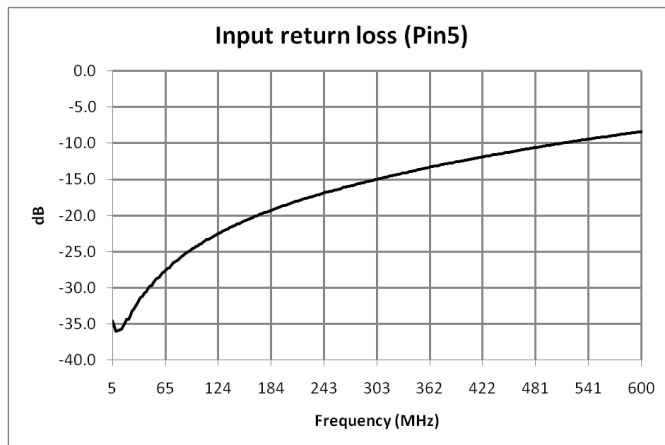
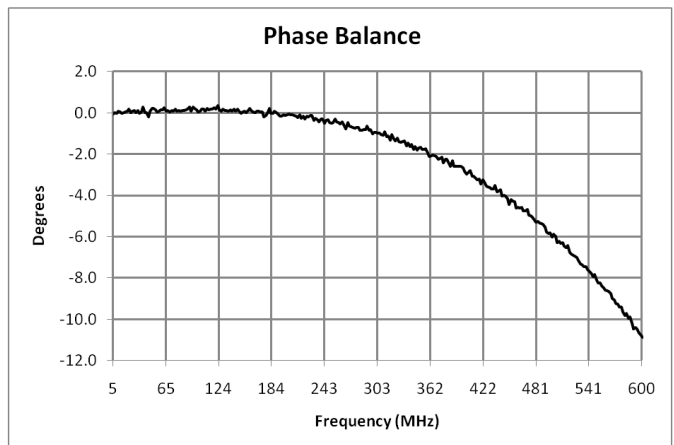
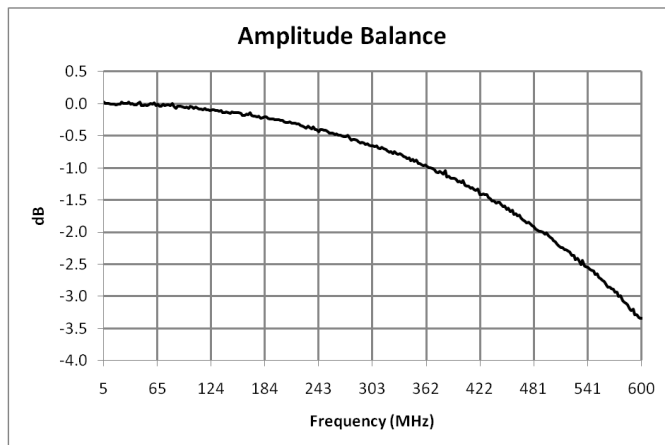
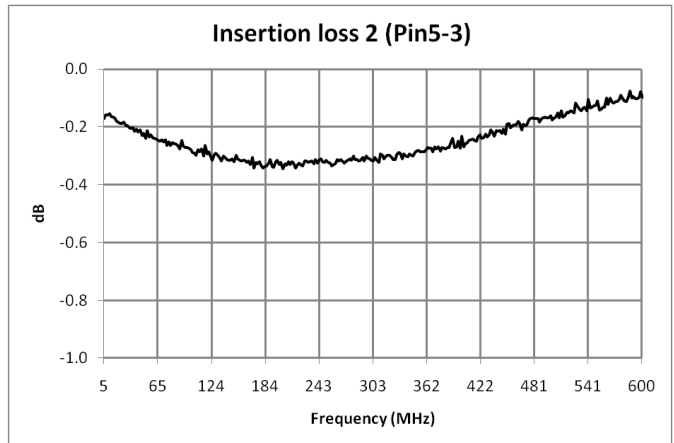
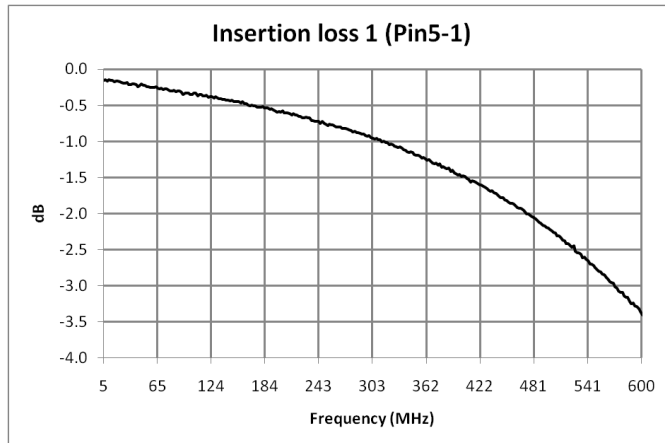

Electrical Specifications:  $Z_0 = 75\Omega$ ,  $T_A = 25^\circ\text{C}$ ,  $P_{in} = 0\text{dBm}$

**1:1 Flux Coupled Balun Transformer  
5 - 300 MHz**

Rev. V7

**Electrical Specifications(unun performance):  $T_A = 25^\circ\text{C}$ , 0dBm,  $Z_0 = 75\Omega$**

Parameter	Conditions	Units	Min	Typ	Max
Frequency Range		MHz	5		300
Impedance		$\Omega$		75	
Impedance Ratio				1:1	
Insertion Loss 1 (Pin5 - Pin3)	5 - 75 MHz	dB	-	0.26	0.35
	75 - 120 MHz	dB	-	0.31	0.40
	120 - 204 MHz	dB	-	0.38	0.45
	204 - 300 MHz	dB	-	0.43	0.55
Phase (Pin5 - Pin3) (Nominal phase difference is 180 degrees)	5 - 75 MHz	$^\circ$	17	13	-
	75 - 120 MHz	$^\circ$	25	22	-
	120 - 204 MHz	$^\circ$	40	37	-
	204 - 300 MHz	$^\circ$	-57	53	-
Input Return Loss (Pin5)	5 - 75 MHz	dB	27	36	-
	75 - 120 MHz	dB	23	31	-
	120 - 204 MHz	dB	19	28	-
	204 - 300 MHz	dB	16	25	-
Output Return Loss (Pin3)	5 - 75 MHz	dB	27	37	-
	75 - 120 MHz	dB	24	31	-
	120 - 204 MHz	dB	19	27	-
	204 - 300 MHz	dB	16	23	-

Electrical Specifications:  $Z_0 = 75\Omega$ ,  $T_A = 25^\circ\text{C}$ ,  $P_{in} = 0\text{dBm}$

## 1:1 Flux Coupled Balun Transformer 5 - 300 MHz

Rev. V7

### Pin Configuration(unun)

Function	Pin Number
Ground	1
Centre Tap(not connected)	2
Output	3
Ground	4
Input	5

### Schematic(unun)

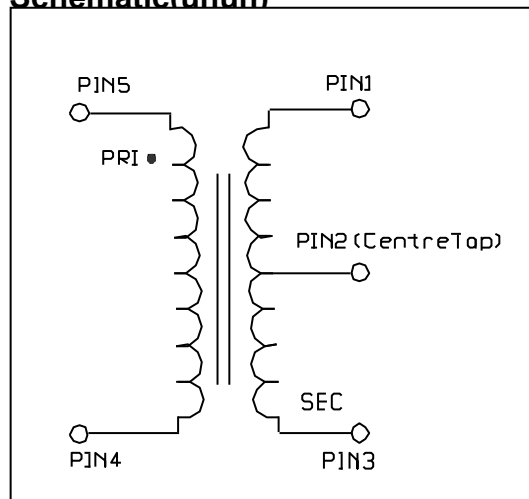

### Application Circuit(unun)

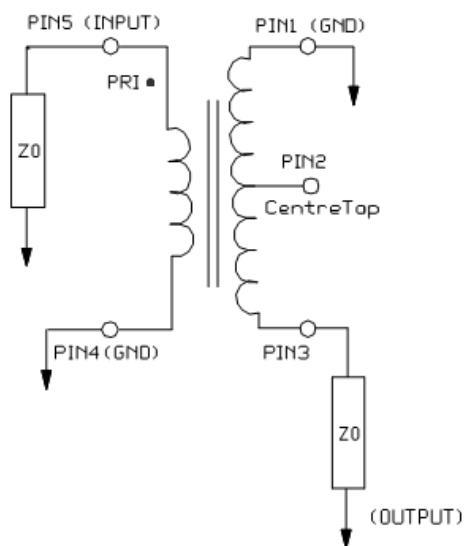

## 1:1 Flux Coupled Balun Transformer 5 - 300 MHz

Rev. V7

