

Features

- Moderate Speed, CMOS Technology (25 ns)
- Complementary Outputs
- High Drive Current Capability (± 50 mA)
- Low Current Consumption
- Lead-Free SOIC-8 Plastic Package
- 260°C Reflow Compatible
- RoHS* Compliant Version of DR65-0003
- Tape and Reel Packaging Available

Applications

- Aerospace & Defense
- ISM

Description

The MADR-007097 is a SPDT driver used to interface between TTL logic signals and PIN diode based microwave switches. High-speed analog CMOS technology is used to achieve low power consumption at moderate speeds. Low output resistances allow it to develop high output current spikes to ensure fast switching speeds. The complementary output stages are structured so it can be used as an inverting or non-inverting driver for SPST switches, or as a single input, complementary driver for SPDT switches.

The monolithic die is packaged in a SOIC-8, plastic surface mount package and is available in tape and reel packaging for high volume applications.

The MADR-007097 driver is ideally suited for driving MACOM's line of HMIC switches.

Functional Block Diagram

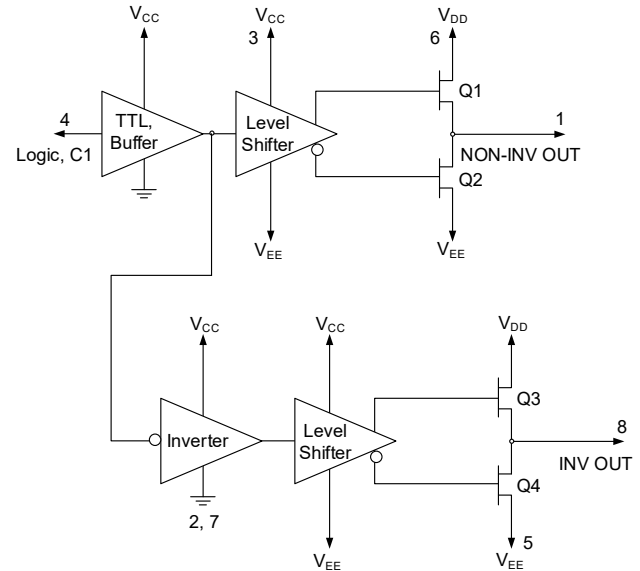

Pin Configuration

Pin #	Function	Pin #	Function
1	NON-INV OUT	5	V_{EE}
2	GND	6	V_{DD}
3	V_{CC}	7	GND
4	C1 (TTL Logic)	8	INV OUT

Ordering Information¹

Part Number	Package
MADR-007097-000100	Bulk Packaging
MADR-007097-0001TR	1000 piece reel

1. Reference Application Note M513 for reel size information.

* Restrictions on Hazardous Substances, compliant to current RoHS EU directive.

Electrical Specifications: $T_A = +25^{\circ}\text{C}$, $+V_{CC} = +V_{DD} = +5\text{ V} \pm 5\%$, $V_{EE} = -5\text{ V} \pm 5\%$, $Z_0 = 50\ \Omega$

Parameter	Test Conditions	Units	Min.	Typ.	Max.
Switching Speed ² Delay Rt/Ft	Spike current into 10 Ω load 50 % TTL to 90% 10%-90%; 90%-10%	ns	—	25 2	35 5
PRF	50% duty cycle	MHz	DC	—	5
Output Voltage Drop, No Load	With reference to supply voltage	V	—	—	0.25
DC Output Current Peak Spike Output Current	Load Dependant Spiking Capacitor in Circuit	mA	—	± 30 ± 150	± 50 ± 200
Output Stage on Resistance	Positive Output FET, Qp Negative Output FET, Qn	W	—	15 10	20 15
Quiescent Supply Currents	+5 V -5 V	mA	—	—	1.5 0.2
TTL Levels	Logic "0" @ 20 μA sink current Logic "1" @ 20 μA source current	V	0 2.0	—	0.8 5.0
Package Dissipation	—	mW	—	—	200

2. Decoupling capacitors (0.01 μF) are required on power supply lines.

Absolute Maximum Ratings^{3,4}

Parameter	Absolute Maximum
V_{CC}	$-0.5\text{ V} \leq V_{CC} \leq +7.0\text{ V}$
V_{DD}	$-0.5\text{ V} \leq V_{DD} \leq V_{CC}$
V_{EE}	$-7.0\text{ V} \leq V_{EE} \leq +0.5\text{ V}$
C1 (TTL Input Voltage)	-0.5 V to $V_{CC} + 0.5\text{ V}$
Operating Temperature	-40°C to $+85^{\circ}\text{C}$
Storage Temperature	-65°C to $+125^{\circ}\text{C}$

- 3. Exceeding any one or combination of these limits may cause permanent damage to this device.
- 4. MACOM does not recommend sustained operation near these survivability limits.

Truth Table

Input	Output	
	NON-INV OUT	INV OUT
Logic "0"	V_{EE}	V_{DD}
Logic "1"	V_{DD}	V_{EE}

Handling Procedures

Please observe the following precautions to avoid damage:

Static Sensitivity

These electronic devices are sensitive to electrostatic discharge (ESD) and can be damaged by static electricity. Proper ESD control techniques should be used when handling these devices.

SPDT Microwave Switch with Driver

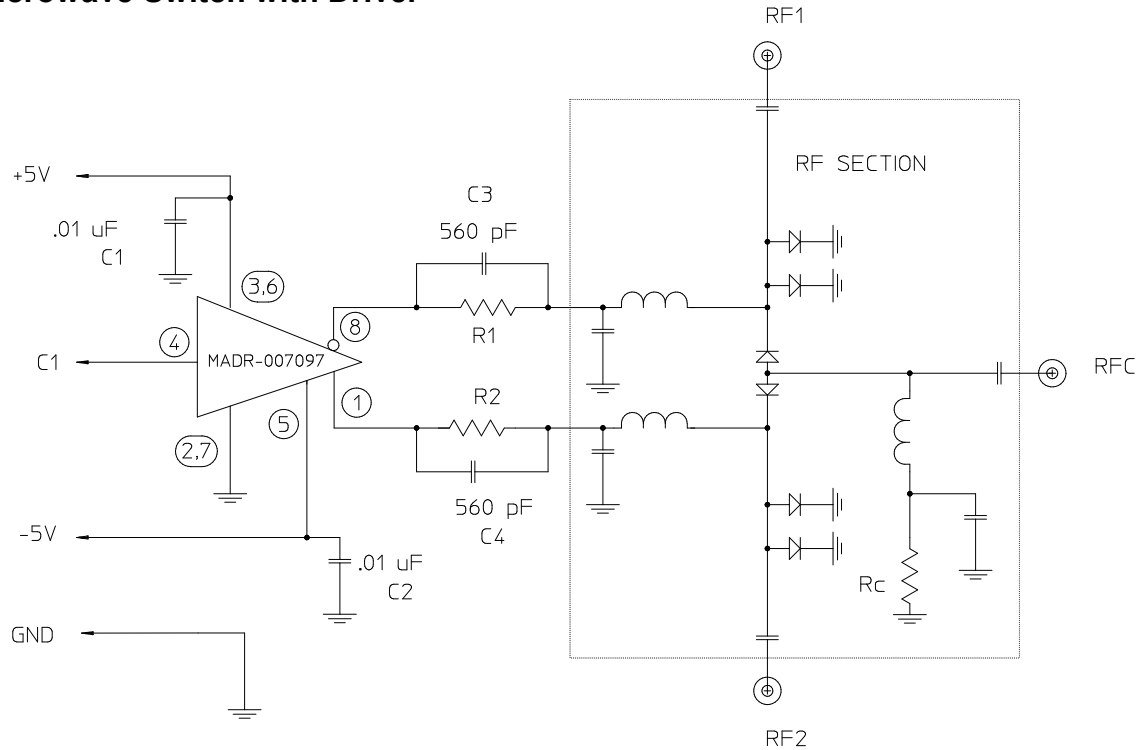

Selection of PIN diodes and bias structure values will affect the switching speed. For switching speed applications slower than 1 μ s, remove C3, C4 and RC.

I_{out} ($\pm 20\%$)	R1, R2	R_c
10	360 Ω	62 Ω
20	200 Ω	30 Ω
30	120 Ω	20 Ω

Lead-Free, SOIC-8[†]

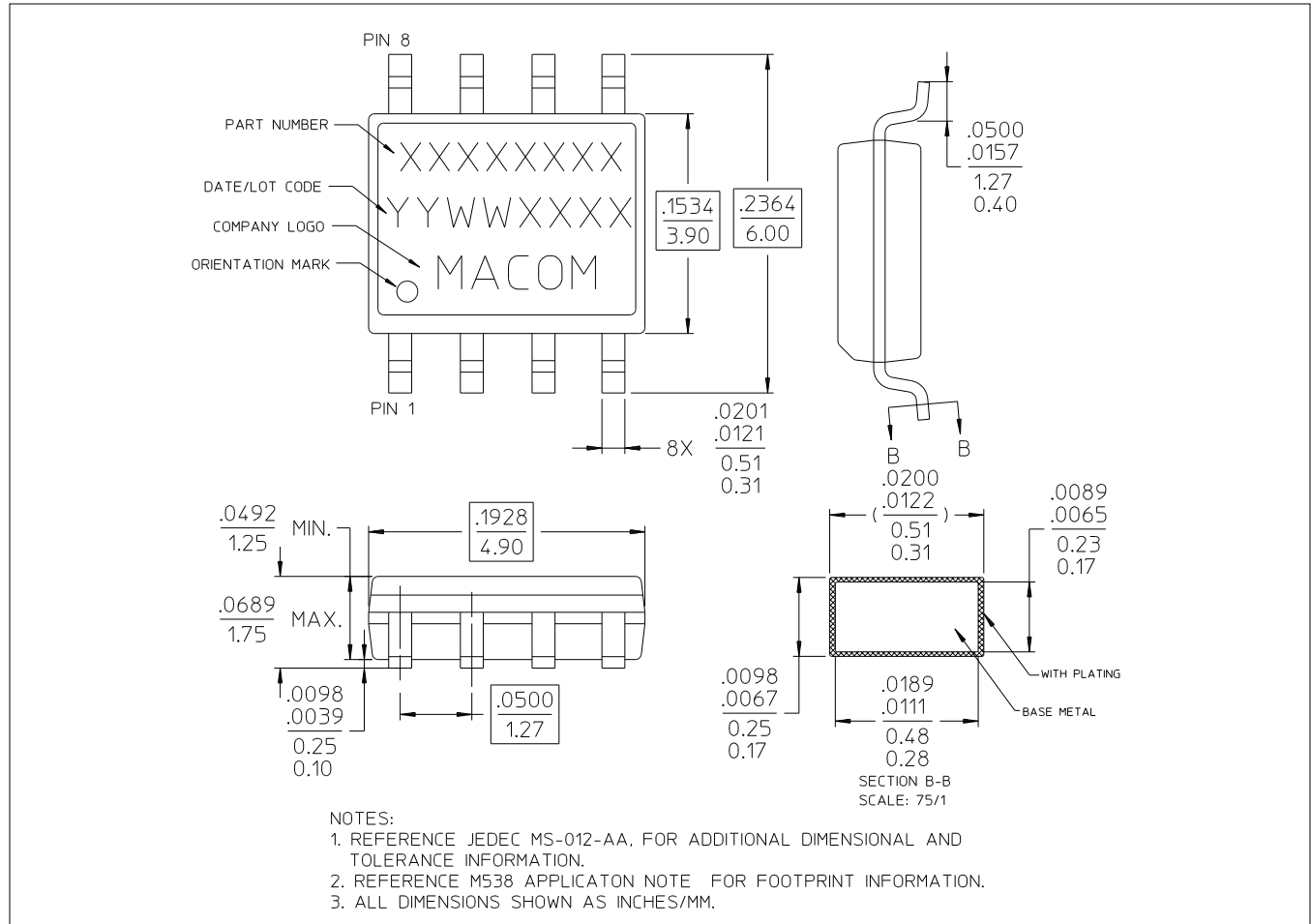

[†] Reference Application Note M538 for lead-free solder reflow recommendations.