

Integrated Dual Channel Switch and LNA Module 2 - 6 GHz



MAMF-011133

Rev. V3

Features

- Dual Channel Architecture
- Broadband: 2 - 6 GHz
- High Power Switch Handling ($T_C = 105^\circ\text{C}$):
43 dBm LTE 8 dB PAR (<10 s, single event)
40 dBm LTE 8 dB PAR (Lifetime)
- Second LNA has Bypass Mode
- Rx High Gain Mode:
Gain: 35 dB at 2.6 GHz, 34 dB @ 3.5 GHz
NF: 1.3 dB at 2.6 GHz, 1.5 dB @ 3.5 GHz
OIP3: 35.5 dBm
- Rx Low Gain Mode:
Gain: 19.3 dB at 2.6 GHz, 19.5 dB @ 3.5 GHz
NF: 1.2 dB at 2.6 GHz, 1.5 dB @ 3.5 GHz
OIP3: 30.5 dBm
- Single 5 V Supply, 115 mA per channel
- Compatible with 1.8 V and 3.3 V logic
- Lead-Free 6 mm 40-Lead QFN Package
- RoHS* Compliant

Applications

- 5G Massive MIMO
- Wireless Infrastructure
- TDD-based communication systems

Description

The highly integrated Dual Channel Switch and LNA Module includes two Antenna Switches and two 2-stage low noise amplifiers in a compact low cost 6 mm QFN package. The second stage LNAs can be bypassed. Mixed technologies are used to achieve high power handling, low noise figure, and low power consumption. The module only needs a single +5 V supply. T/R switch, LNA enable, and bypass function can be controlled with 1.8 V or 3.3 V logic.

Ordering Information¹

Part Number	Package
MAMF-011133-TR1000	1000 part reel
MAMF-011133-001SMB	Sample Board

1. Reference Application Note M513 for reel size information.

Functional Schematic

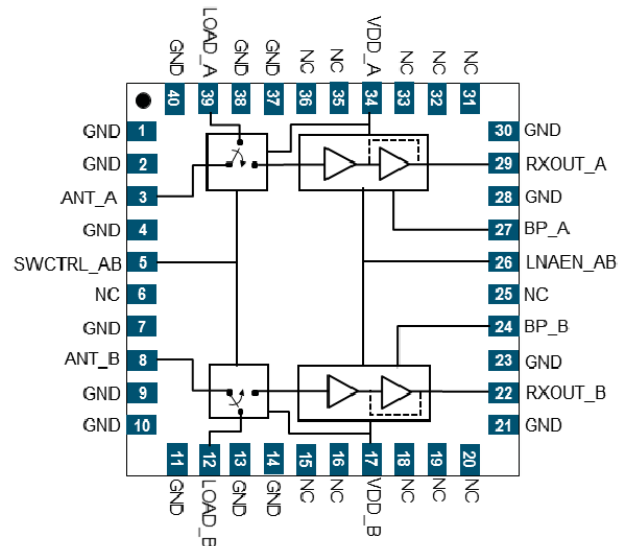

Pin Configuration^{2,3,4}

Pin #	Function
1, 2, 4, 7, 9-11, 13, 14, 21, 23, 28, 30, 37, 38, 40	Ground
3	Antenna Input ChA
5	Switch Control ChA & B
6, 15, 16, 18-20, 25, 31-33, 35, 36	No Connect
8	Antenna Input ChB
12	Load ChB
17	V _{DD} ChB
22	Rx Output ChB
24	LNA Bypass ChB
26	LNA Enable ChA & B
27	LNA Bypass ChA
29	Rx Output ChA
34	V _{DD} ChA
39	Load ChA

2. Blocking Capacitors are required on all RF Ports.

3. MACOM recommends connecting unused package pins to ground.

4. The exposed pad centered on the package bottom must be connected to RF, DC and thermal ground.

* Restrictions on Hazardous Substances, compliant to current RoHS EU directive.

Pin Description

Pin #	Name	Description
1, 2, 4, 7, 9-11, 13, 14, 21, 23, 28, 30, 37, 38, 40	Ground	These pins are grounded internally.
3	Antenna Input ChA	Antenna Input Channel A. This pin is DC-coupled and matched to 50Ω. A DC blocking capacitor is required on this pin.
5	Switch Control ChA & B	Logic Switch Control for both Channel A and Channel B.
6, 15, 16, 18-20, 25, 31-33, 35, 36	No Connect	Not connected internally.
8	Antenna Input ChB	Antenna Input Channel B. This pin is DC-coupled and matched to 50Ω. A DC blocking capacitor is required on this pin.
12	Load ChB	Load Channel B. This pin is DC-coupled and matched to 50Ω. A DC blocking capacitor is required on this pin.
17	V _{DD} ChB	LNA and Switch Supply for Channel B
22	Rx Output ChB	RX Output Channel B. This pin is DC-coupled and matched to 50Ω. A DC blocking capacitor is required on this pin.
24	LNA Bypass ChB	Logic LNA Bypass Control for Channel B.
26	LNA Enable ChA & B	Logic LNA Enable Control for both Channel A and Channel B.
27	LNA Bypass ChA	Logic LNA Bypass Control for Channel A.
29	Rx Output ChA	RX Output Channel A. This pin is DC-coupled and matched to 50Ω. A DC blocking capacitor is required on this pin.
34	V _{DD} ChA	LNA and Switch Supply for Channel A
39	Load ChA	Load Channel A. This pin is DC-coupled and matched to 50Ω. A DC blocking capacitor is required on this pin.
Paddle	GND	Exposed Pad. The exposed pad must be connected to a large RF/DC ground island providing thermal capabilities for heat dissipation.

Electrical Specifications: Freq. = 2.6 GHz, P_{IN} = -35 dBm, T_C = +25°C, V_{DD} = 5 V, Z₀ = 50 Ω

Parameter	Conditions	Units	Min.	Typ.	Max.
Gain at Rx High Gain Mode	2.6 GHz 3.5 GHz 5.0 GHz	dB	31 30 29	35 34 32	—
NF at Rx High Gain Mode	2.6 GHz 3.5 GHz 5.0 GHz	dB	—	1.3 1.5 1.7	—
Input RL at Rx High Gain Mode	—	dB	—	18	—
Output RL at Rx High Gain Mode	—	dB	—	15	—
Output IP3 at Rx High Gain Mode	Tone Spacing = 10 MHz P _{OUT} / Tone = +3 dBm P _{OUT} / Tone = +10 dBm	dBm	—	33 35.5	—
Output P1dB at Rx High Gain Mode	—	dBm	—	19.5	—
Gain at Rx Low Gain Mode	2.6 GHz 3.5 GHz 5.0 GHz	dB	17 17 16	19.3 19.5 19.0	—
NF at Rx Low Gain Mode	2.6 GHz 3.5 GHz 5.0 GHz	dB	—	1.2 1.5 1.7	—
Input RL at Rx Low Gain Mode	—	dB	—	15	—
Output RL at Rx Low Gain Mode	—	dB	—	11.5	—
Output IP3 at Rx Low Gain Mode	Tone Spacing = 10 MHz P _{OUT} / Tone = +3 dBm	dBm	—	30.5	—
Output P1dB at Rx Low Gain Mode	—	dBm	—	15.5	—
Insertion Loss at Tx Mode	—	dB	—	0.35	—
Return Loss at Tx Mode	—	dB	—	25	—
Power Handling at Tx Mode	Average Power (8 dB PAR)	W	—	10	—
Supply Voltage	—	V	4.75	5.0	5.25
Control Voltage	Logic High Logic Low	V	1.2 0	—	3.45 0.6
Logic Input Current	Logic High Logic Low	μA	—	+80 -2	—
Supply Current (V _{DD}) per Channel	Rx High Gain Rx Low Gain Tx mode	mA	—	115 50 2	—

Electrical Specifications: Freq. = 2.6 GHz, P_{IN} = -35 dBm, T_C = +25°C, V_{DD} = 5 V, Z₀ = 50 Ω

Parameter	Conditions	Units	Min.	Typ.	Max.
RF Switching Time	50% CTL to 10/90% RF	ns	—	500	—
High/Low Gain Mode Switching Time	50% CTL to 10/90% RF	ns	—	150	—
Isolation Between Rx Channels ⁵	2.6 GHz 3.5 GHz 5.0 GHz	dB	—	47.0 42.5 41.5	—
Switch Isolation, ANT to Load	Rx Mode, 2.6 GHz Rx Mode, 3.5 GHz	dB	—	20 17	—
Switch Isolation, ANT to Rx output	Tx Mode	dB	—	72	—

5. Test conditions: both Rx channels are enabled. RF signal is present at Antenna port on one of the channels only. The isolation is defined as the difference between the 2 RX output signal levels.

Control Truth Table

Mode	SWCTRL_AB	LNAEN_AB	BP_A/B	Note
RX mode	Low or Open	Low or Open	Low or Open	HGM ⁶
RX mode	Low or Open	Low or Open	High	LGM ⁷
TX mode	High	High	Low or Open	Power Down
TX mode	High	High	High	Power Down

6. HGM: High Gain Mode.

7. LGM: Low Gain Mode.

Absolute Maximum Ratings^{8,9}

Parameter	Absolute Maximum
Antenna Input Power ¹⁰ Freq. = 2.6 GHz: RX Mode TX Mode	22 dBm LTE (8 dB PAR), 22 dBm CW 43 dBm LTE (8 dB PAR), 43 dBm CW
DC Voltages: ANT_A/B, LOAD_A/B, RXOUT_A/B VDD_A/B, SWCTRL_A/B, LNAEN_A/B, BP_A/B	-0.3 to +3.6 V -0.3 to +5.5 V -0.3 to +3.6 V
Junction Temperature: RX Mode ^{11,13} TX Mode ^{11,13} TX Mode ¹⁰	+150°C +125°C +140°C
Operating Temperature ¹²	-40°C to +105°C
Storage Temperature	-55°C to +150°C

8. Exceeding any one or combination of these limits may cause permanent damage to this device.

9. MACOM does not recommend sustained operation near these survivability limits.

10. Single event, up to 10 seconds duration.

11. Operating at nominal conditions with $T_J \leq +150^\circ\text{C}$ (RX Mode) and $T_J \leq +125^\circ\text{C}$ (TX Mode) will ensure $\text{MTTF} \gg 1 \times 10^6$ hours.

12. Operating/Case temperature (T_C) is the temperature of the exposed paddle.

13. Junction Temperature (T_J) = $T_C + \Theta_{JC} * P_{DISS}$ where P_{DISS} is the total DC & RF dissipated power.

- RX Mode: Typical thermal resistance (Θ_{JC}) = 33.4 °C/W.
- TX Mode: Typical thermal resistance (Θ_{JC}) = 9.8 °C/W.

Handling Procedures

Please observe the following precautions to avoid damage:

Static Sensitivity

These electronic devices are sensitive to electrostatic discharge (ESD) and can be damaged by static electricity. Proper ESD control techniques should be used when handling these devices.

Power Supplies

De-coupling capacitors should be placed at the V_{DD} supply pin to minimize noise and fast transients. Supply voltage change or transients should have a slew rate smaller than 1 V / 10 μs . In addition, all control pins should remain at 0 V (+/- 0.3 V) and no RF power should be applied while the supply voltage ramps or while it returns to zero.

Parameter	Rating	Standard
Human Body Model (HBM)	500 V Class 1B	ESDA/JEDEC JS-001
Charged Device Model (CDM)	1000 V (Class C3)	ESDA/JEDEC JS-002

Integrated Dual Channel Switch and LNA Module 2 - 6 GHz



MAMF-011133

Rev. V3

PCB Layout

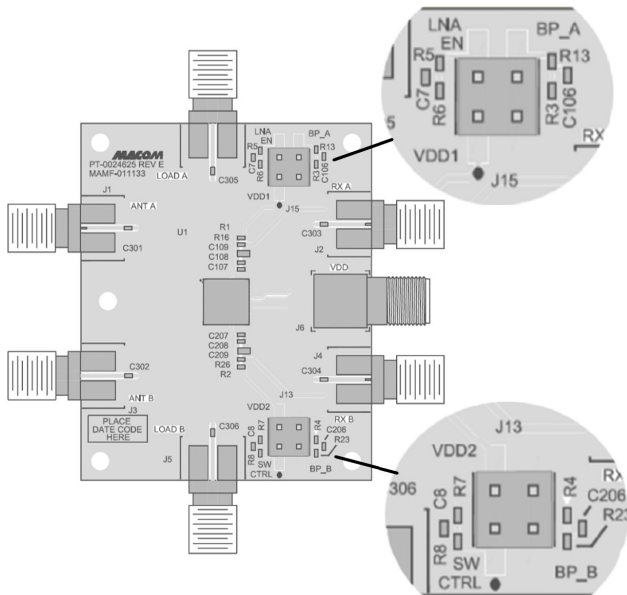

Parts List

Part	Value	Case Style
C7, C8, C106, C206	5 pF	0402
C107, C207	470 pF	0402
C108, C208	10 nF	0402
C109, C209	10 μ F	0603
C301 - C306	20 pF	0402
R1, R2, R3, R4, R6, R7	0 R	0402
R16, R26	DNP	0402
R5, R8, R13, R23	1 k Ω	0402

14. Proposed SMB parts list provides supply biasing for CH1 and CH2 via DC headers (J15/J13) with separate V_{DD1} and V_{DD2} supplies. A single V_{DD} supply may also be provided at the SMA connector (J6) by removing R1/R2 and populating R16/R26 with 0 R instead.

Application Schematic

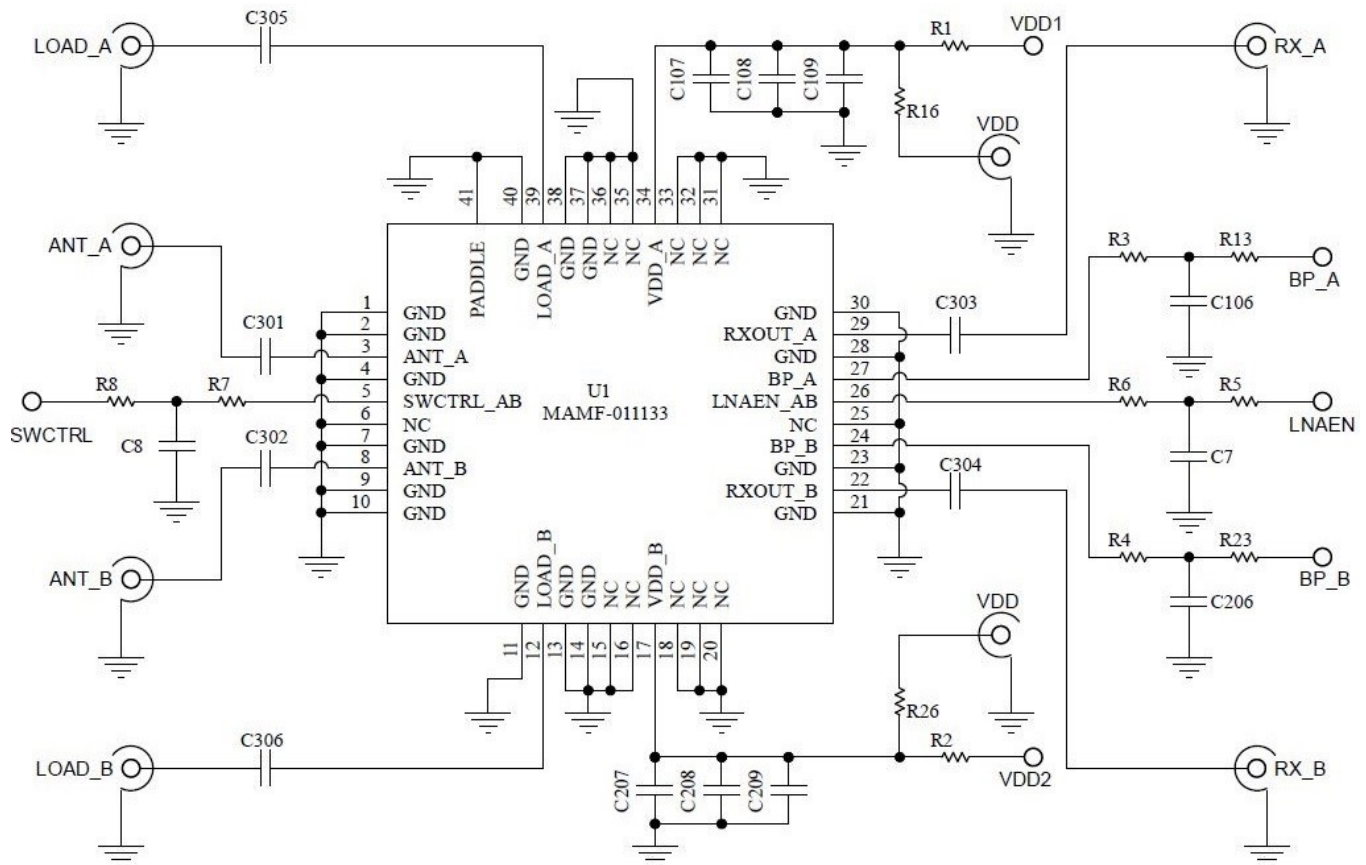

Integrated Dual Channel Switch and LNA Module

2 - 6 GHz



MAMF-011133

Rev. V3

Typical Performance Curves:

$P_{IN} = -35 \text{ dBm}$, $V_{DD} = 5 \text{ V}$, $T_C = +25^\circ\text{C}$, $Z_0 = 50 \Omega$ (unless otherwise indicated)

Channel A LNA Gain over swept Frequency (& Temp.) in Rx High Gain Mode

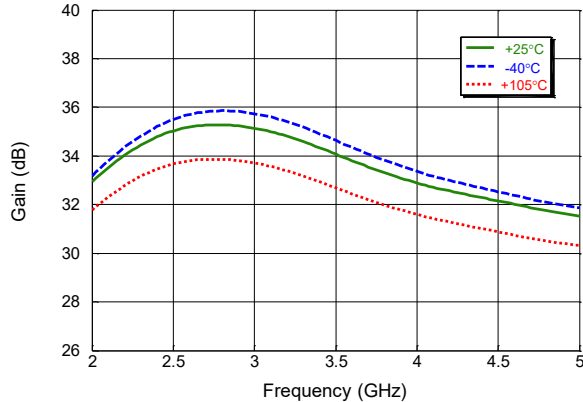

Channel B LNA Gain over swept Frequency (& Temp.) in Rx High Gain Mode

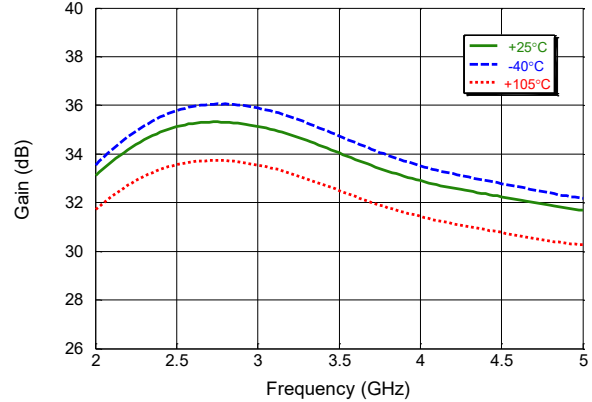

Channel A ANT Port Return Loss over swept Frequency (& Temp.) in Rx High Gain Mode

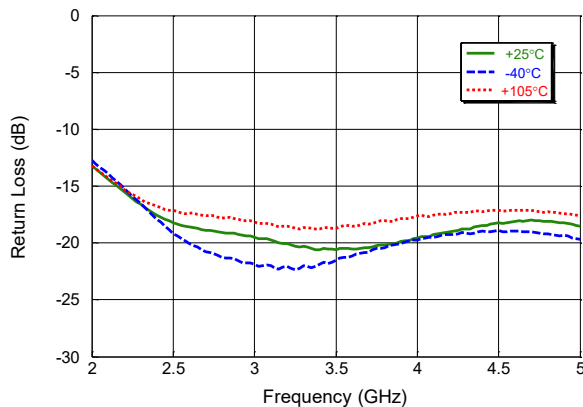

Channel B ANT Port Return Loss over swept Frequency (& Temp.) in Rx High Gain Mode

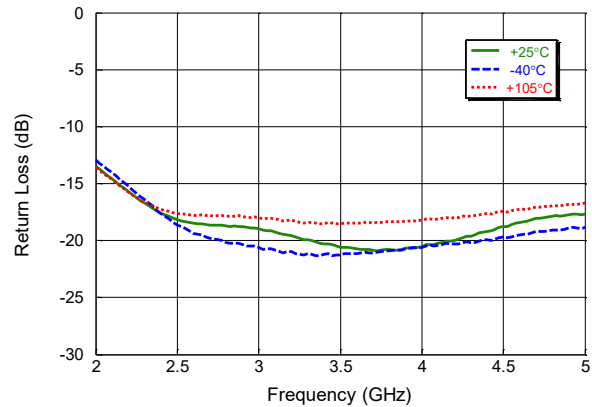

Channel A RXOUT Port Return Loss over swept Frequency (& Temp.) in Rx High Gain Mode

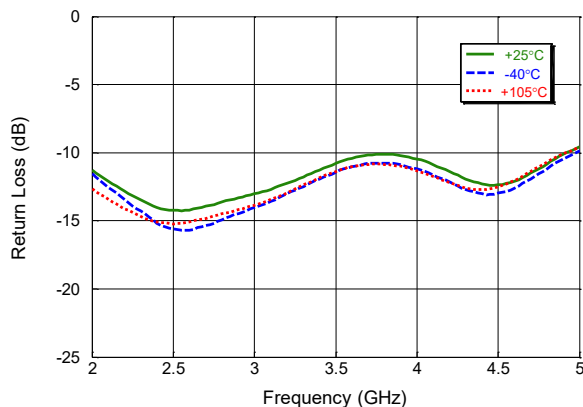

Channel B RXOUT Port Return Loss over swept Frequency (& Temp.) in Rx High Gain Mode

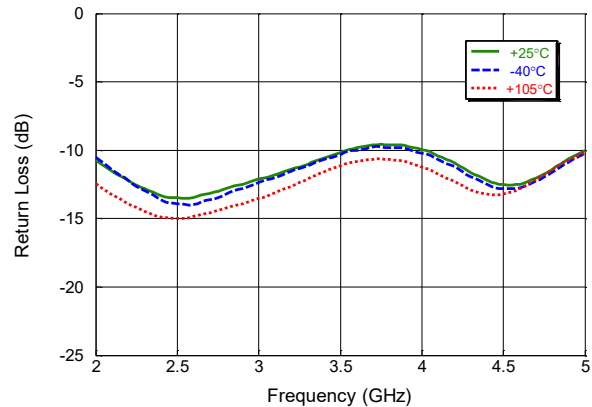

Typical Performance Curves:

$P_{IN} = -35 \text{ dBm}$, $V_{DD} = 5 \text{ V}$, $T_C = +25^\circ\text{C}$, $Z_0 = 50 \Omega$ (unless otherwise indicated)

Channel A LNA Gain over swept Frequency (& Temp.) in Rx Low Gain Mode

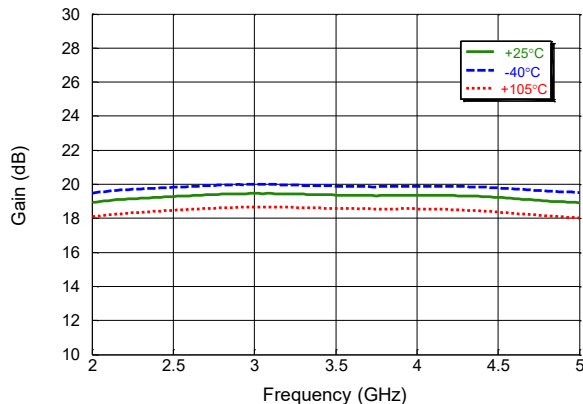

Channel B LNA Gain over swept Frequency (& Temp.) in Rx Low Gain Mode

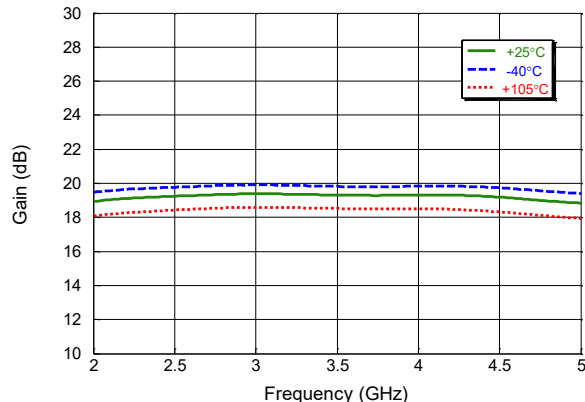

Channel A ANT Port Return Loss over swept Frequency (& Temp.) in Rx Low Gain Mode

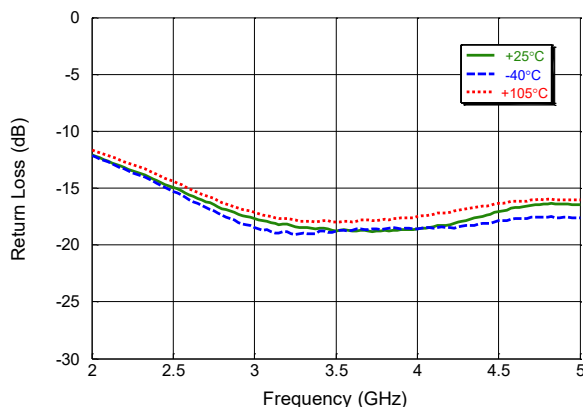

Channel B ANT Port Return Loss over swept Frequency (& Temp.) in Rx Low Gain Mode

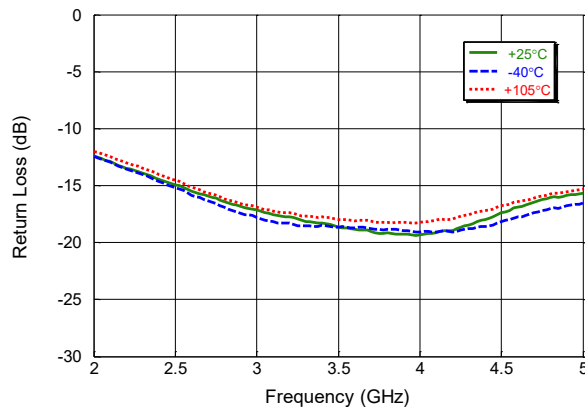

Channel A RXOUT Port Return Loss over swept Frequency (& Temp.) in Rx Low Gain Mode

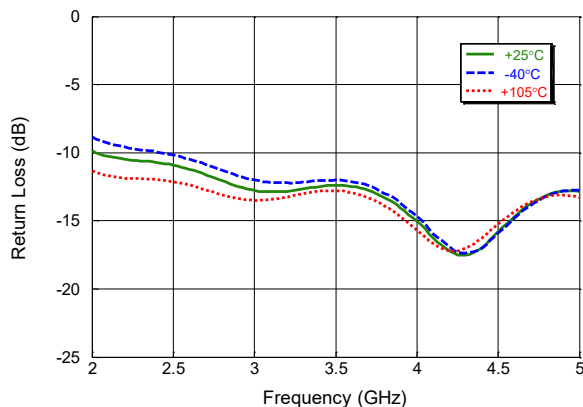

Channel B RXOUT Port Return Loss over swept Frequency (& Temp.) in Rx Low Gain Mode

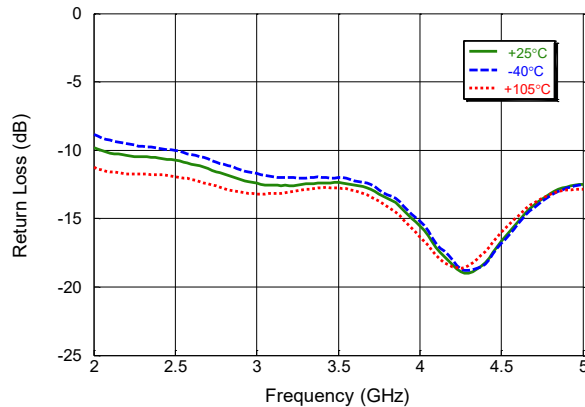

Typical Performance Curves:

$P_{IN} = -35 \text{ dBm}$, $V_{DD} = 5 \text{ V}$, $T_C = +25^\circ\text{C}$, $Z_0 = 50 \Omega$ (unless otherwise indicated)

Channel A LNA Noise Figure over swept Frequency (& Temp.) in Rx High Gain Mode

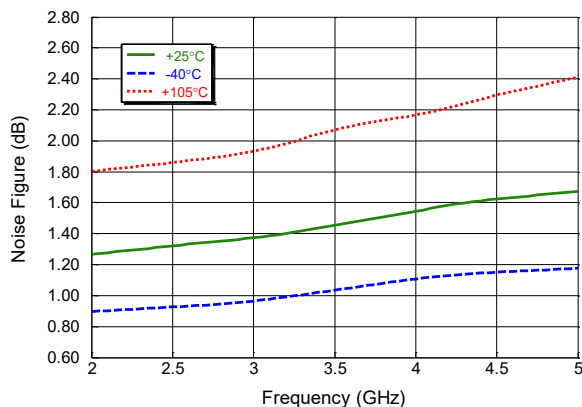

Channel B LNA Noise Figure over swept Frequency (& Temp.) in Rx High Gain Mode

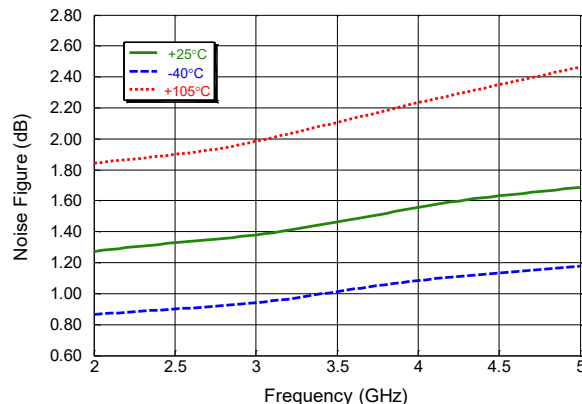

Channel A LNA Noise Figure over swept Frequency (& Temp.) in Rx Low Gain Mode

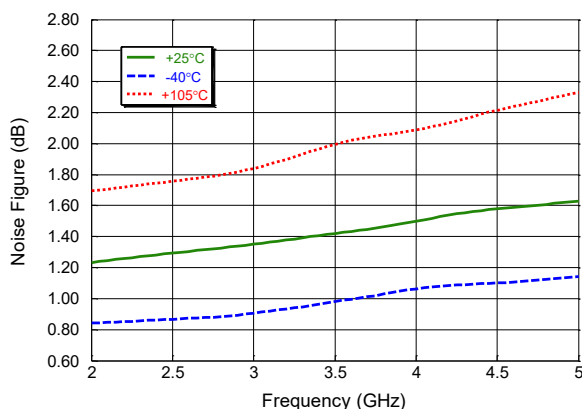

Channel B LNA Noise Figure over swept Frequency (& Temp.) in Rx Low Gain Mode

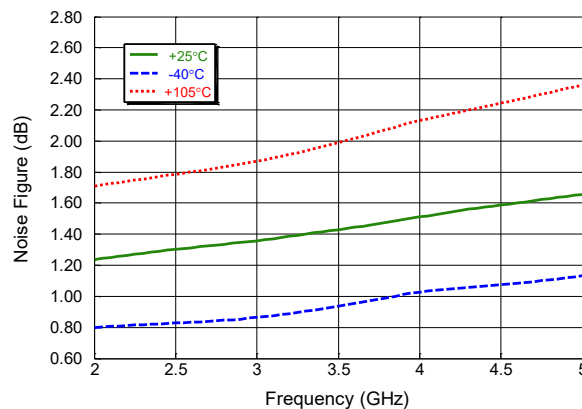

Channel A ANT to LOAD Isolation over swept Frequency (& Temp.) in Rx High Gain Mode

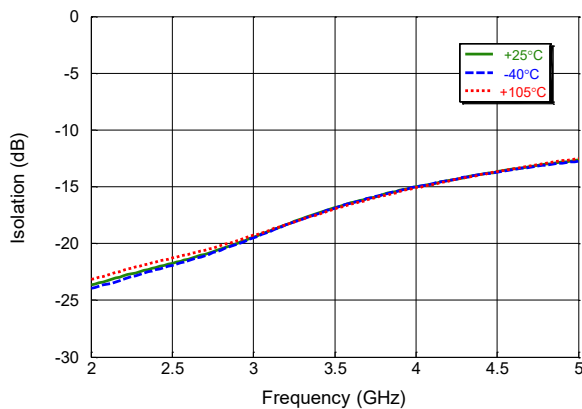

Channel B ANT to LOAD Isolation over swept Frequency (& Temp.) in Rx High Gain Mode

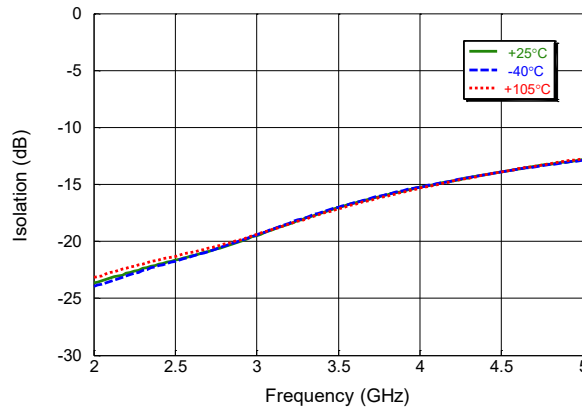

Typical Performance Curves:

$P_{IN} = -35 \text{ dBm}$, $V_{DD} = 5 \text{ V}$, $T_C = +25^\circ\text{C}$, $Z_0 = 50 \Omega$ (unless otherwise indicated)

Channel A ANT to LOAD Isolation over swept Frequency (& Temp.) in Rx Low Gain Mode

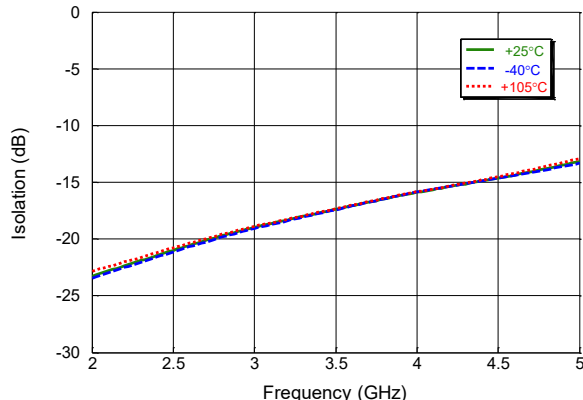

Channel B ANT to LOAD Isolation over swept Frequency (& Temp.) in Rx Low Gain Mode

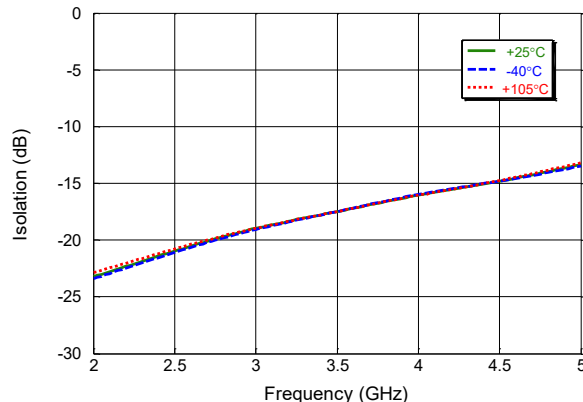

Channel A LNA Output P1dB over swept Frequency (& Temp.) in Rx High Gain Mode

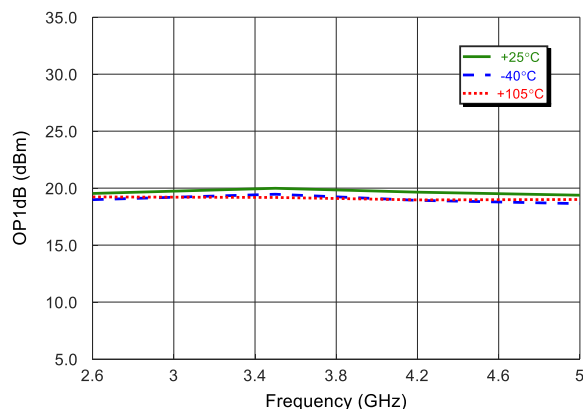

Channel B LNA Output P1dB over swept Frequency (& Temp.) in Rx High Gain Mode

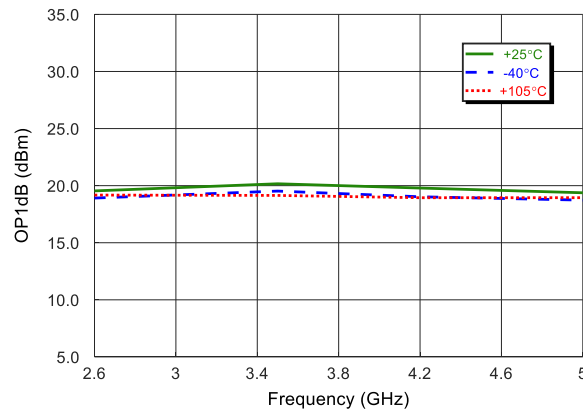

Channel A LNA Output P1dB over swept Frequency (& Temp.) in Rx Low Gain Mode.

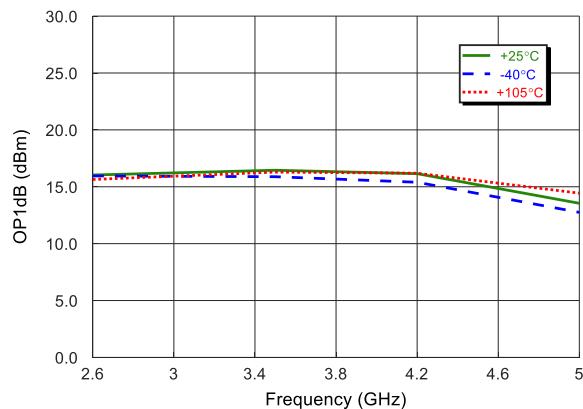

Channel B LNA Output P1dB over swept Frequency (& Temp.) in Rx Low Gain Mode

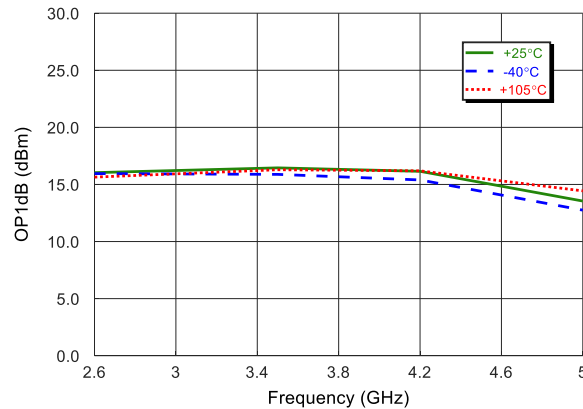

Typical Performance Curves:

$P_{IN} = -35 \text{ dBm}$, $V_{DD} = 5 \text{ V}$, $T_C = +25^\circ\text{C}$, $Z_0 = 50 \Omega$ (unless otherwise indicated)

Channel A LNA Output P1dB over swept Frequency (& V_{DD}) in Rx High Gain Mode

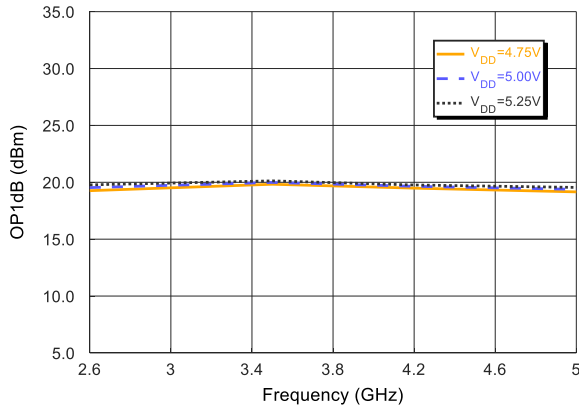

Channel B LNA Output P1dB over swept Frequency (& V_{DD}) in Rx High Gain Mode

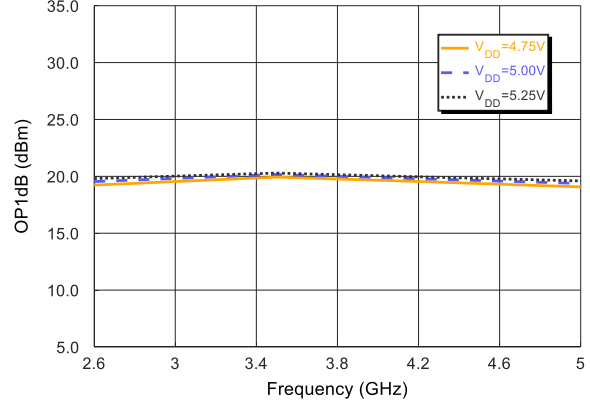

Channel A LNA Output P1dB over swept Frequency (& V_{DD}) in Rx Low Gain Mode

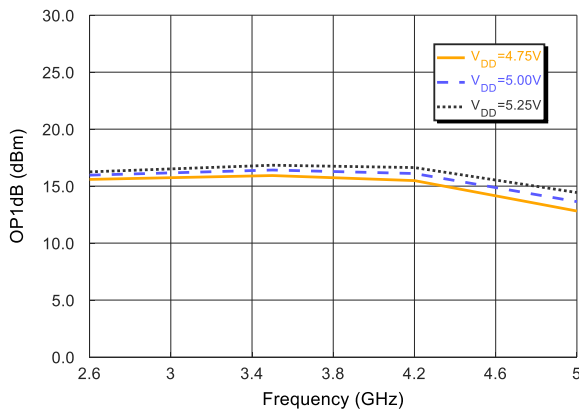

Channel B LNA Output P1dB over swept Frequency (& V_{DD}) in Rx Low Gain Mode

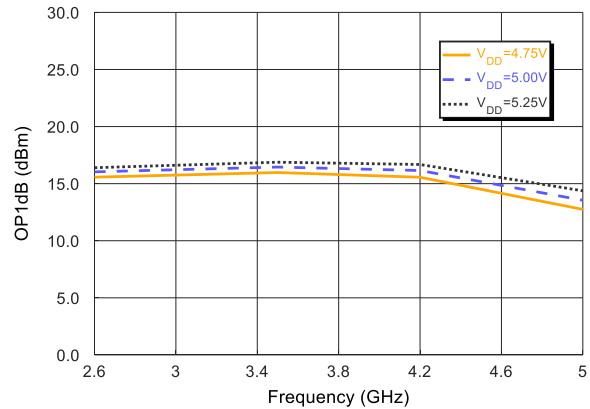

Channel A LNA Gain over Frequency (& V_{DD}) in Rx High Gain Mode

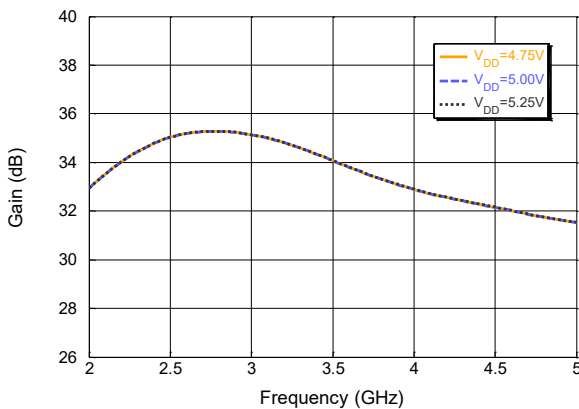

Channel B LNA Gain over Frequency (& V_{DD}) in Rx High Gain Mode

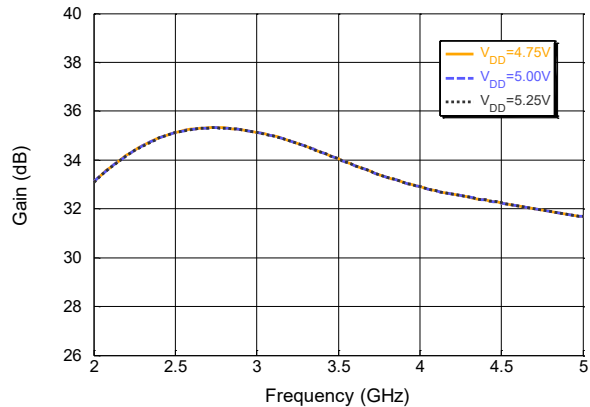

Typical Performance Curves:

$P_{IN} = -35 \text{ dBm}$, $V_{DD} = 5 \text{ V}$, $T_C = +25^\circ\text{C}$, $Z_0 = 50 \Omega$ (unless otherwise indicated)

Channel A OIP3 over swept Frequency (& Temp.) with $P_{OUT}/\text{Tone} = 10 \text{ dBm}$ & 10 MHz tone spacing in HGM.

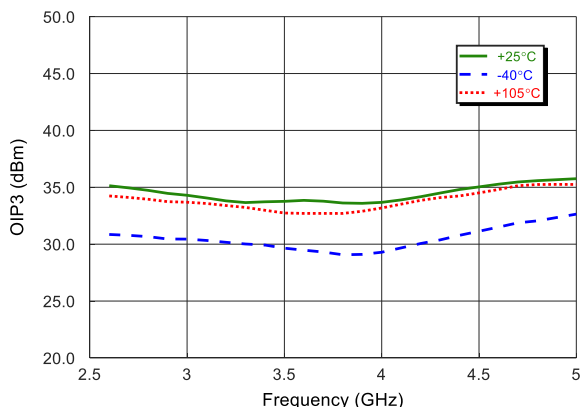

Channel B OIP3 over swept Frequency (& Temp.) with $P_{OUT}/\text{Tone} = 10 \text{ dBm}$ & 10 MHz tone spacing in HGM.

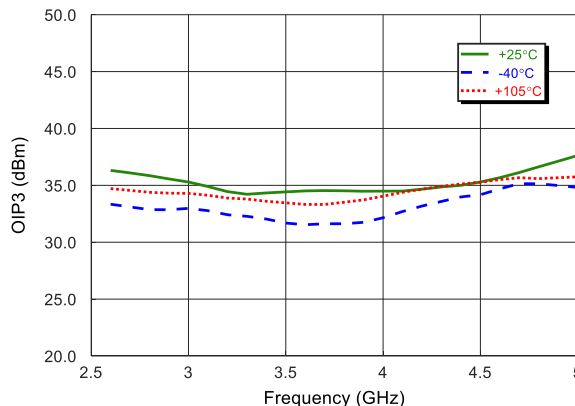

Channel A OIP3 over swept Frequency (& Temp.) with $P_{OUT}/\text{Tone} = 3 \text{ dBm}$ & 10 MHz tone spacing in HGM.

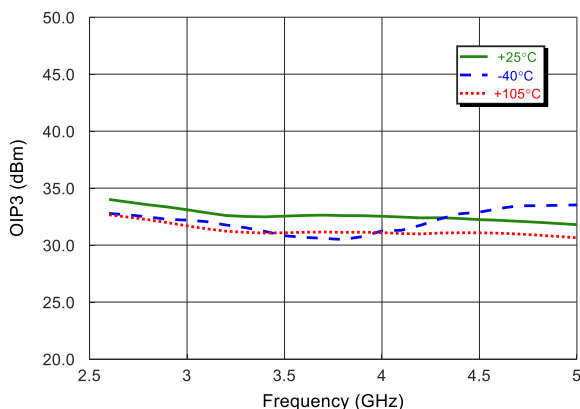

Channel B OIP3 over swept Frequency (& Temp.) with $P_{OUT}/\text{Tone} = 3 \text{ dBm}$ & 10 MHz tone spacing in HGM.

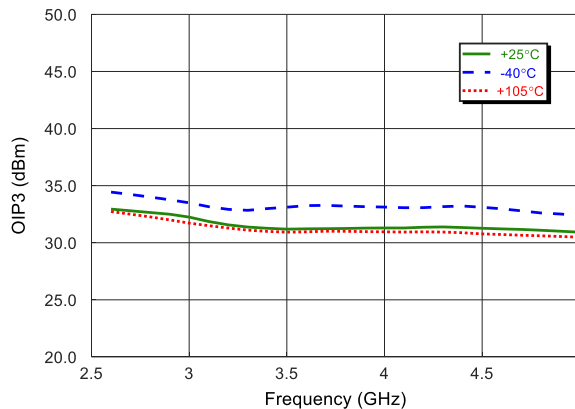

Channel A OIP3 over swept frequency (& V_{DD}) with $P_{OUT}/\text{Tone} = 10 \text{ dBm}$ & 10 MHz tone spacing in HGM.

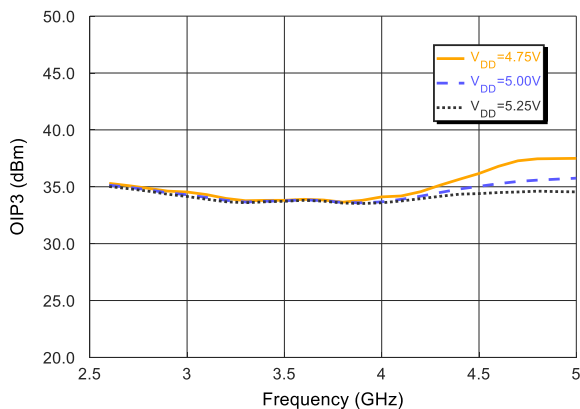

Channel B OIP3 over swept frequency (& V_{DD}) with $P_{OUT}/\text{Tone} = 10 \text{ dBm}$ & 10 MHz tone spacing in HGM.

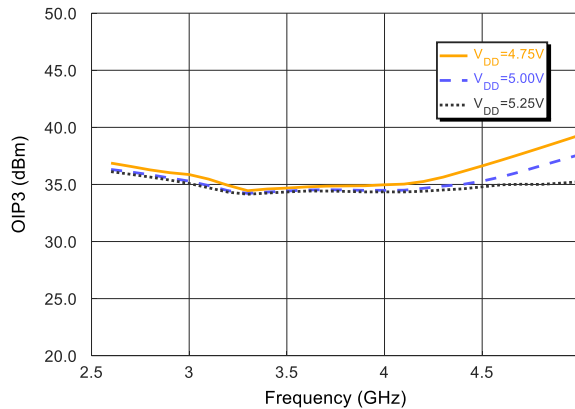

Typical Performance Curves:

$P_{IN} = -35 \text{ dBm}$, $V_{DD} = 5 \text{ V}$, $T_C = +25^\circ\text{C}$, $Z_0 = 50 \Omega$ (unless otherwise indicated)

Channel A OIP3 over swept Frequency (& Temp.) with $P_{OUT}/\text{Tone} = 3 \text{ dBm}$ & 10 MHz tone spacing in LGM.

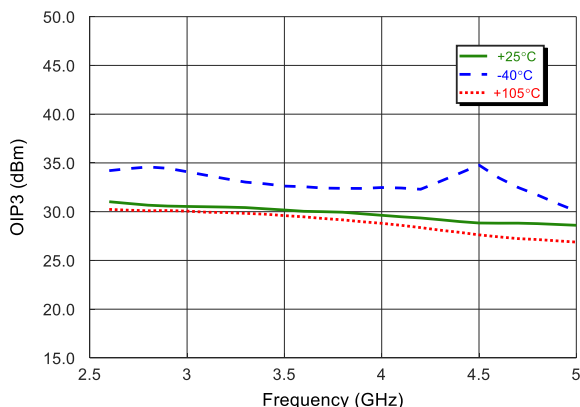

Channel B OIP3 over swept Frequency (& Temp.) with $P_{OUT}/\text{Tone} = 3 \text{ dBm}$ & 10 MHz tone spacing in LGM.

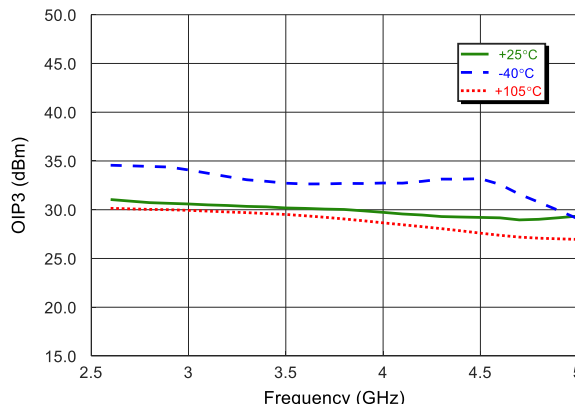

Channel A OIP3 over swept Frequency (& Temp.) with $P_{OUT}/\text{Tone} = 0 \text{ dBm}$ & 10 MHz tone spacing in LGM.

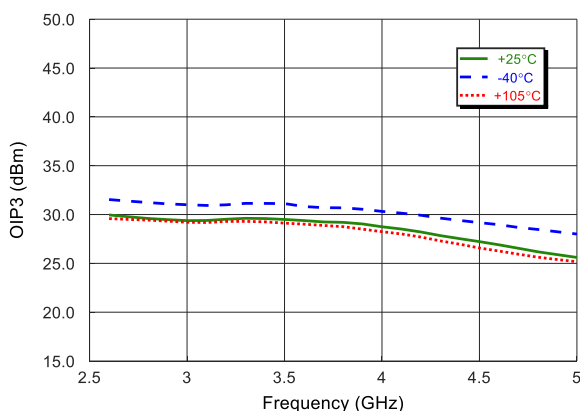

Channel B OIP3 over swept Frequency (& Temp.) with $P_{OUT}/\text{Tone} = 0 \text{ dBm}$ & 10 MHz tone spacing in LGM.

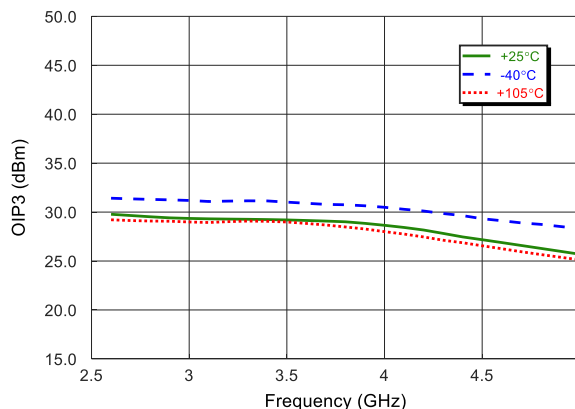

Channel A OIP3 over swept Frequency (& V_{DD}) with $P_{OUT}/\text{Tone} = 0 \text{ dBm}$ & 10 MHz tone spacing in LGM.

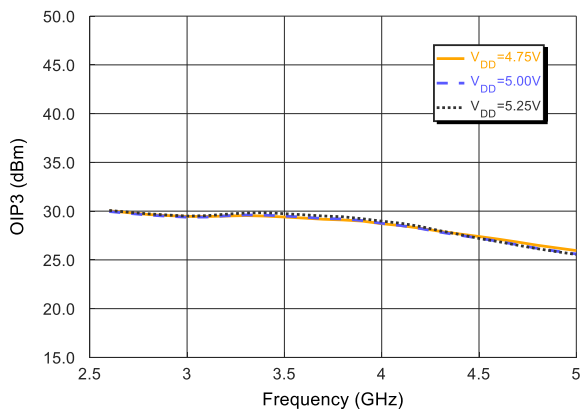

Channel B OIP3 over swept Frequency (& V_{DD}) with $P_{OUT}/\text{Tone} = 0 \text{ dBm}$ & 10 MHz tone spacing in LGM.

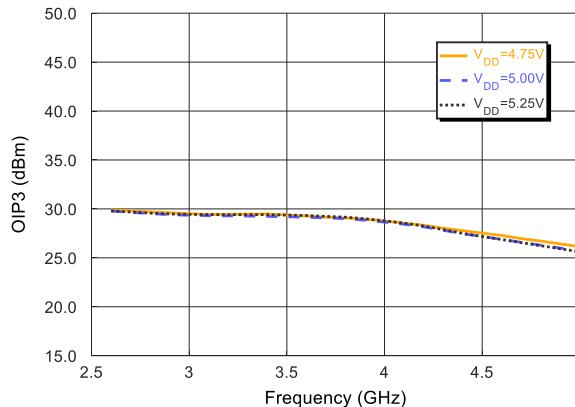

Typical Performance Curves:

$P_{IN} = -35 \text{ dBm}$, $V_{DD} = 5 \text{ V}$, $T_C = +25^\circ\text{C}$, $Z_0 = 50 \Omega$ (unless otherwise indicated)

Channel A OIP3 over swept frequency. $P_{OUT}/\text{Tone} = 6 \text{ dBm}$ with 10 MHz & 50 MHz tone spacing in HGM.

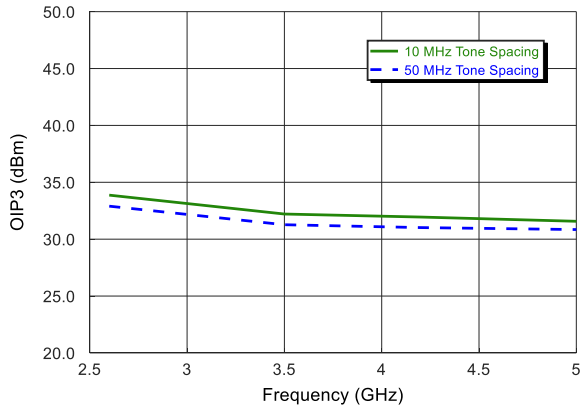

Channel B OIP3 over swept frequency. $P_{OUT}/\text{Tone} = 6 \text{ dBm}$ with 10 MHz & 50 MHz tone spacing in HGM.

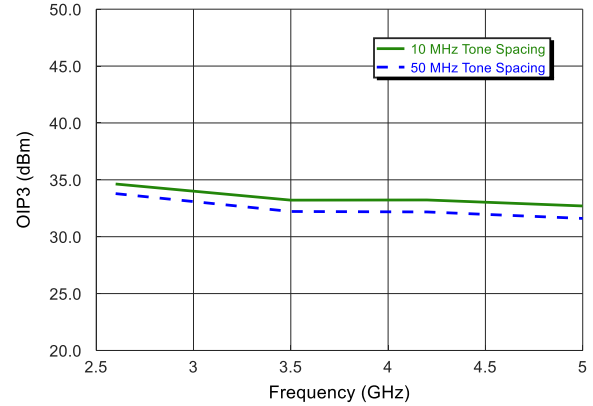

Typical Performance Curves:

$P_{IN} = -35 \text{ dBm}$, $V_{DD} = 5 \text{ V}$, $T_C = +25^\circ\text{C}$, $Z_0 = 50 \Omega$ (unless otherwise indicated)

Channel A Wideband LNA Gain¹⁵ over swept Frequency in Rx High Gain Mode

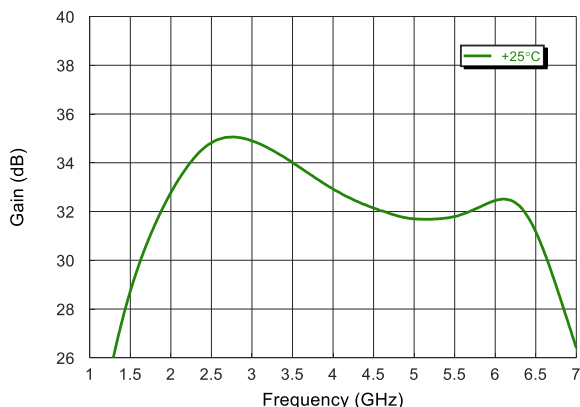

Channel B Wideband LNA Gain¹⁵ over swept Frequency in Rx High Gain Mode

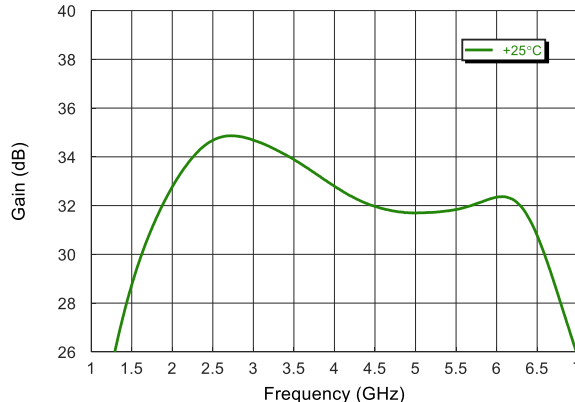

Channel A Wideband ANT Port Return Loss over swept Frequency in Rx High Gain Mode

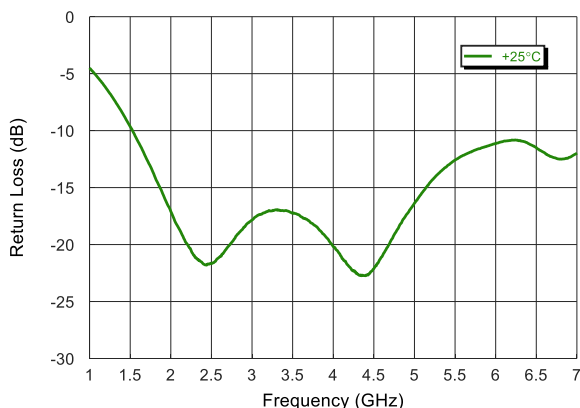

Channel B Wideband ANT Port Return Loss over swept Frequency in Rx High Gain Mode

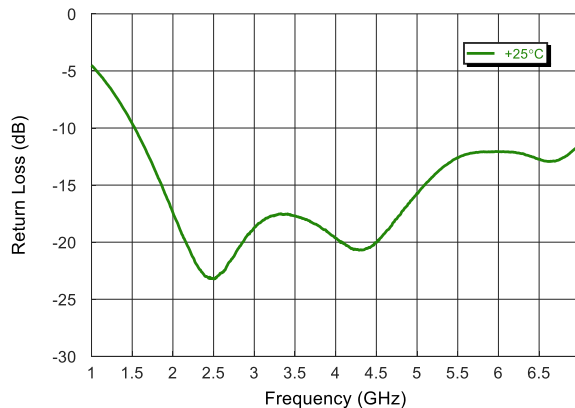

Channel A Wideband RXOUT Port Return Loss over swept Frequency in Rx High Gain Mode

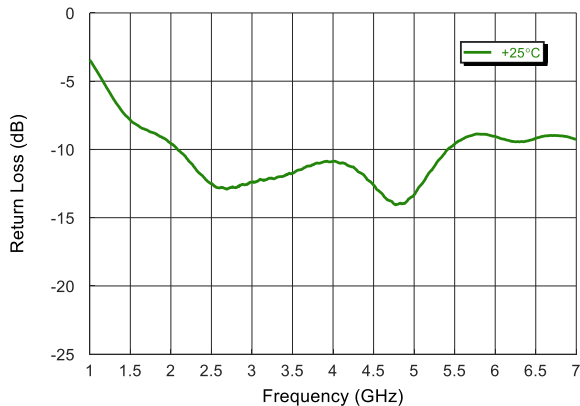

Channel B Wideband RXOUT Port Return Loss over swept Frequency in Rx High Gain Mode

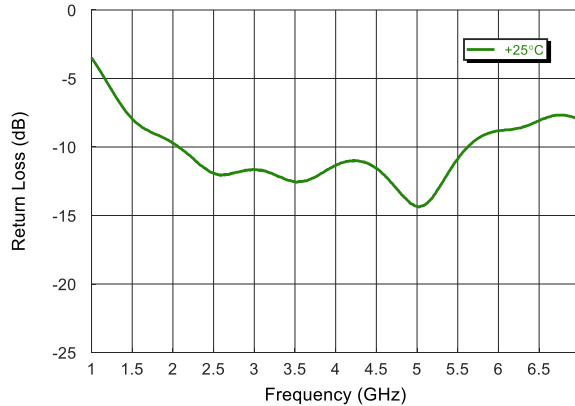

15. For LNA gain, RF trace and connector losses are de-embedded

Typical Performance Curves:

$P_{IN} = -35 \text{ dBm}$, $V_{DD} = 5 \text{ V}$, $T_C = +25^\circ\text{C}$, $Z_0 = 50 \Omega$ (unless otherwise indicated)

Channel A Wideband LNA Gain¹⁶ over swept Frequency in Rx Low Gain Mode

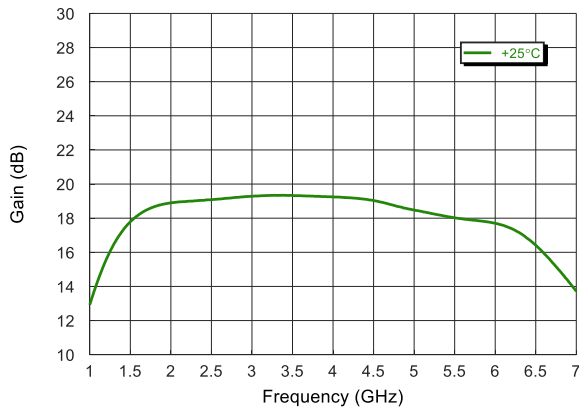

Channel B Wideband LNA Gain¹⁶ over swept Frequency in Rx Low Gain Mode

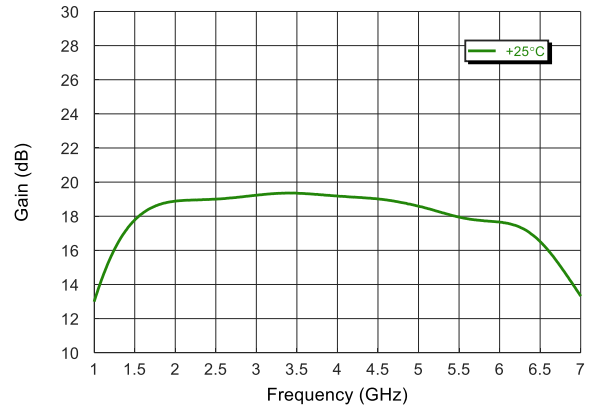

Channel A Wideband ANT Port Return Loss over swept Frequency in Rx Low Gain Mode

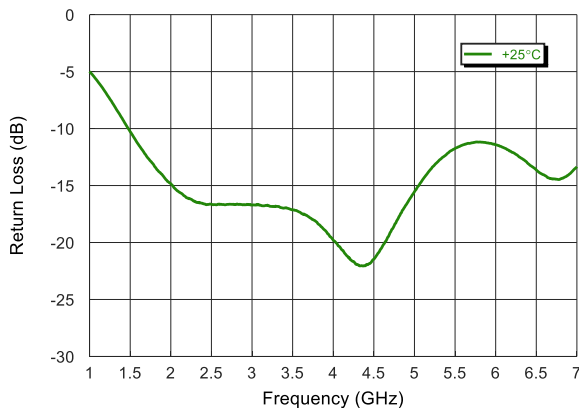

Channel B Wideband ANT Port Return Loss over swept Frequency in Rx Low Gain Mode

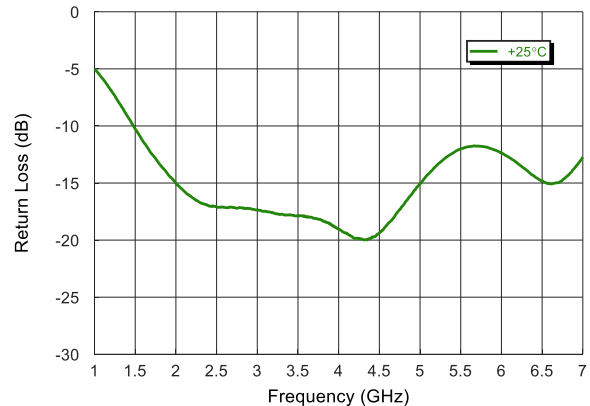

Channel A Wideband RXOUT Port Return Loss over swept Frequency in Rx Low Gain Mode

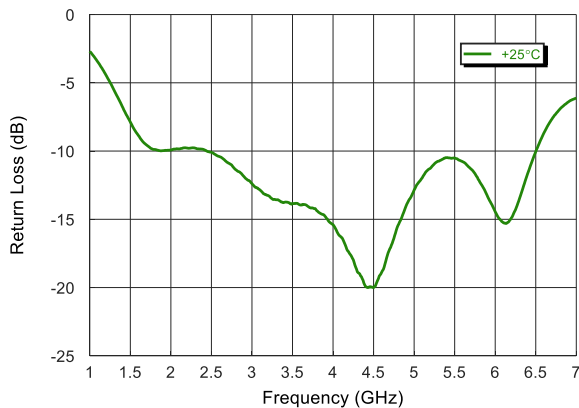

Channel B Wideband RXOUT Port Return Loss over swept Frequency in Rx Low Gain Mode

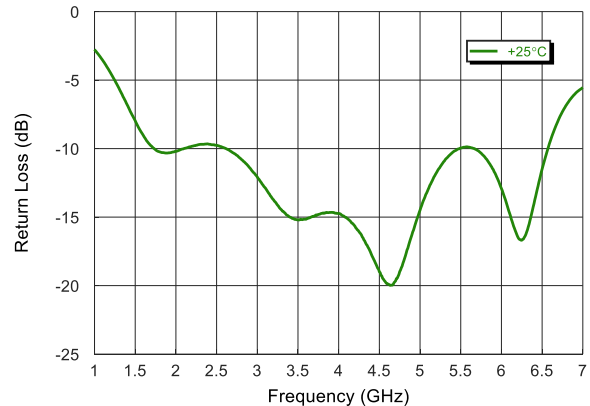

16. For LNA gain, RF trace and connector losses are de-embedded

Typical Performance Curves:

$P_{IN} = -10 \text{ dBm}$, $V_{DD} = 5 \text{ V}$, $T_C = +25^\circ\text{C}$, $Z_0 = 50 \Omega$ (unless otherwise indicated)

Channel A Switch Insertion Loss over swept Frequency (& Temp.) in Tx Mode

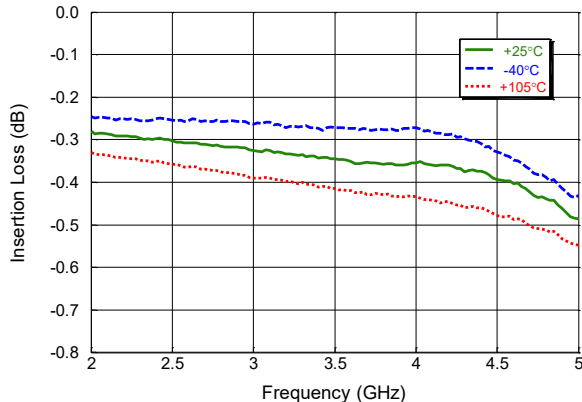

Channel B Switch Insertion Loss over swept Frequency (& Temp.) in Tx Mode

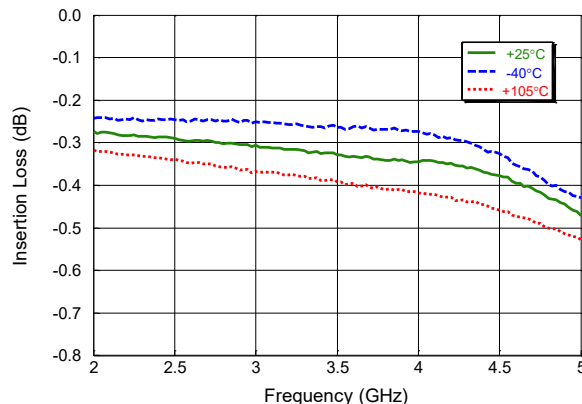

Channel A ANT Port Return Loss over swept Frequency (& Temp.) in Tx Mode

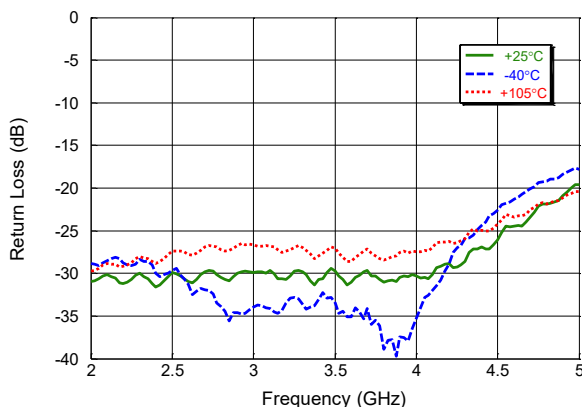

Channel B ANT Port Return Loss over swept Frequency (& Temp.) in Tx Mode

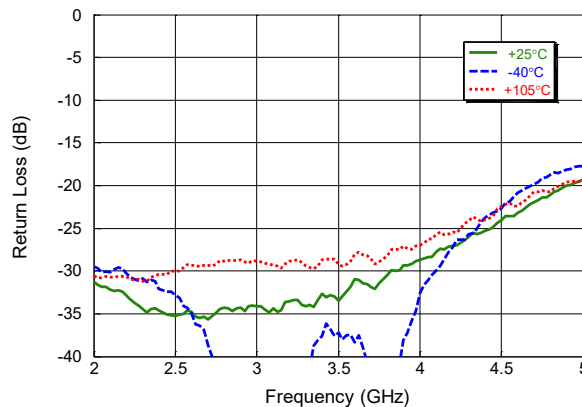

Channel A LOAD Port Return Loss over swept Frequency (& Temp.) in Tx Mode

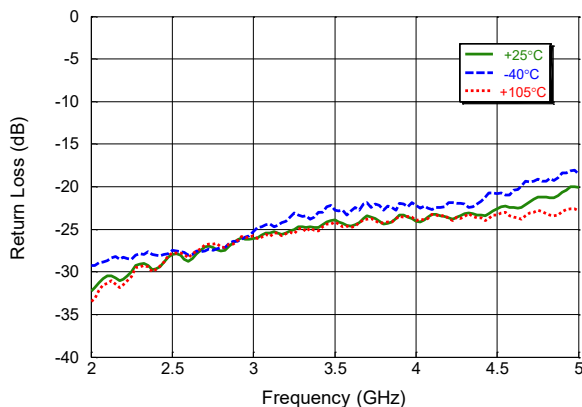

Channel B LOAD Port Return Loss over swept Frequency (& Temp.) in Tx Mode

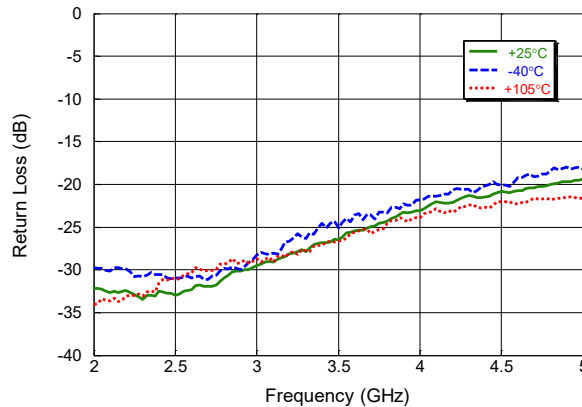

Typical Performance Curves:

$P_{IN} = -10$ dBm, $V_{DD} = 5$ V, $T_C = +25^\circ\text{C}$, $Z_0 = 50 \Omega$ (unless otherwise indicated)

Channel A ANT to RXOUT Isolation over swept Frequency (& Temp.) in Tx Mode

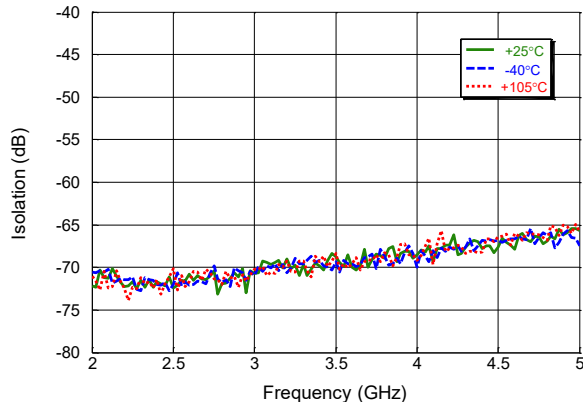

Channel B ANT to RXOUT Isolation over swept Frequency (& Temp.) in Tx Mode

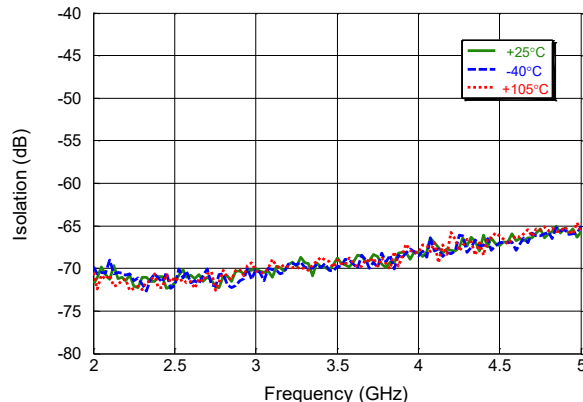

Channel A Switch Insertion Loss over swept Frequency (& V_{DD}) in Tx Mode

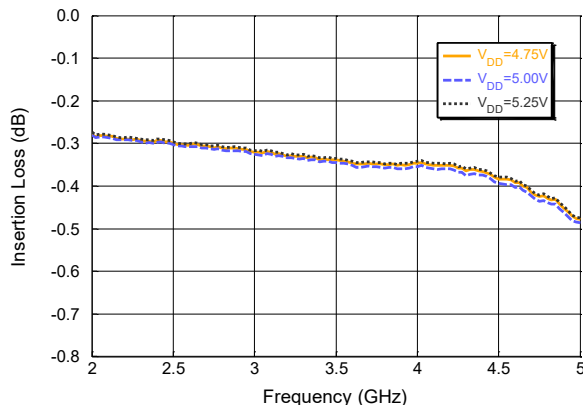

Channel B Switch Insertion Loss over swept Frequency (& V_{DD}) in Tx Mode

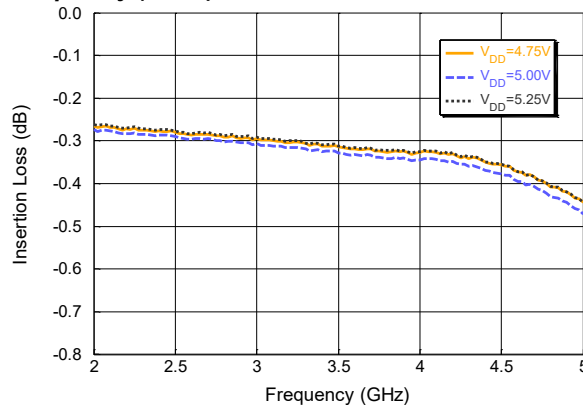

Switch Compression over swept ANT Input Power (& Temp.) at 2.6 GHz in Tx Mode

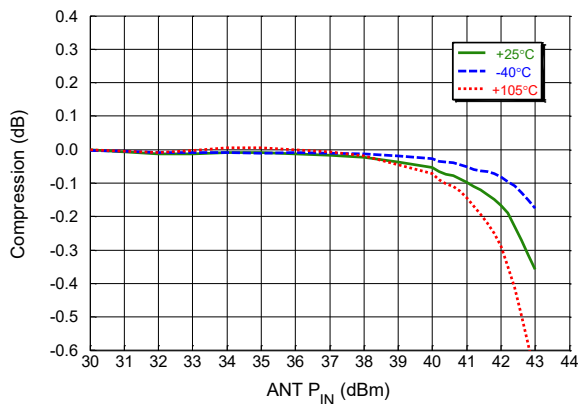

Switch ANT Input P0.1dB Compression Point over swept Frequency (& Temp.) in Tx Mode

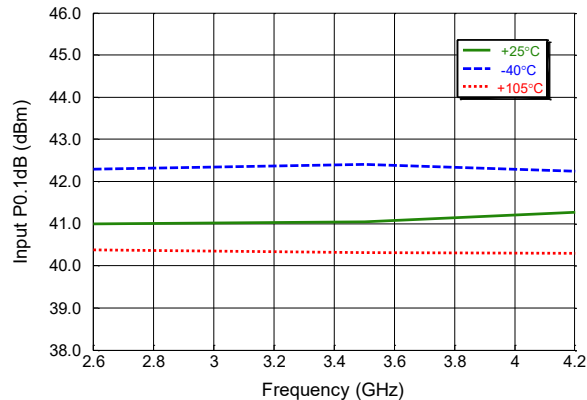

Typical Performance Curves:

$P_{IN} = -10 \text{ dBm}$, $V_{DD} = 5 \text{ V}$, $T_C = +25^\circ\text{C}$, $Z_0 = 50 \Omega$ (unless otherwise indicated)

Channel A Wideband Switch Insertion Loss¹⁷ over swept Frequency in Tx Mode

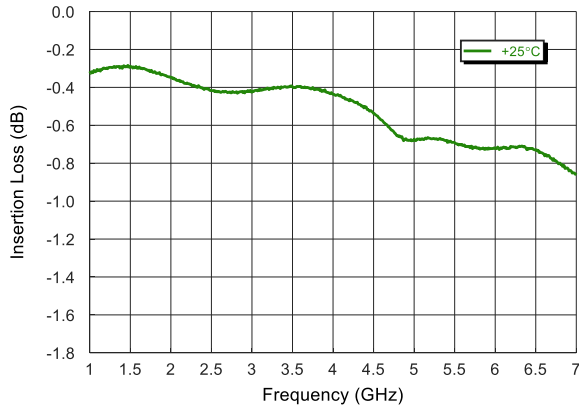

Channel B Wideband Switch Insertion Loss¹⁷ over swept Frequency in Tx Mode

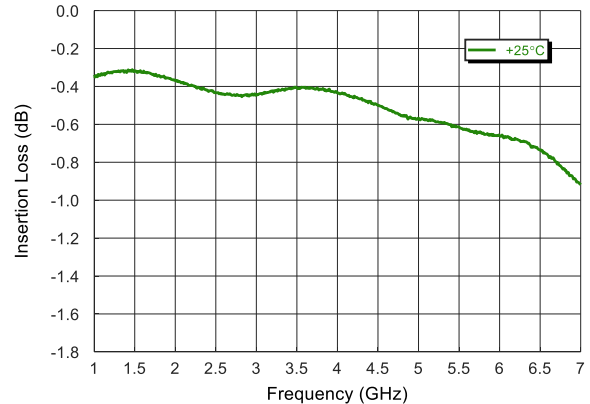

Channel A Wideband ANT Port Return Loss over swept Frequency in Tx Mode

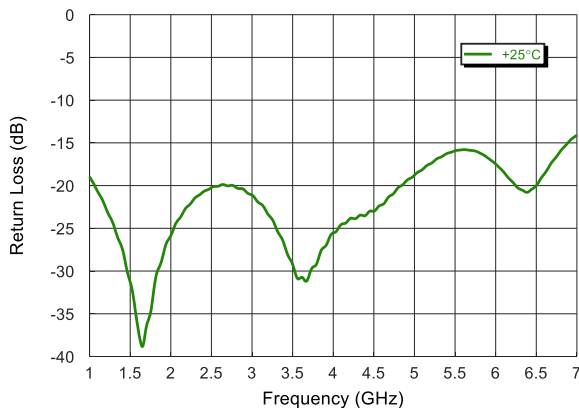

Channel B Wideband ANT Port Return Loss over swept Frequency in Tx Mode

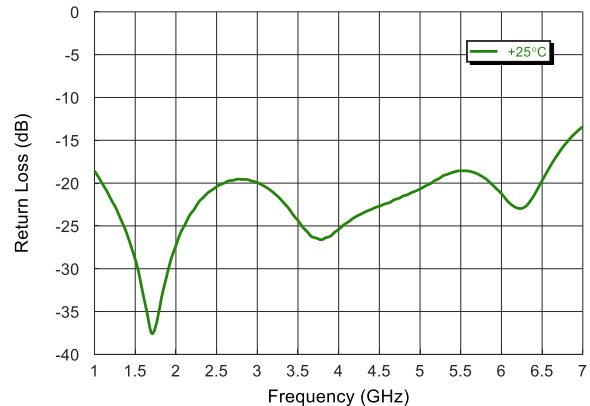

Channel A Wideband LOAD Port Return Loss over swept Frequency in Tx Mode

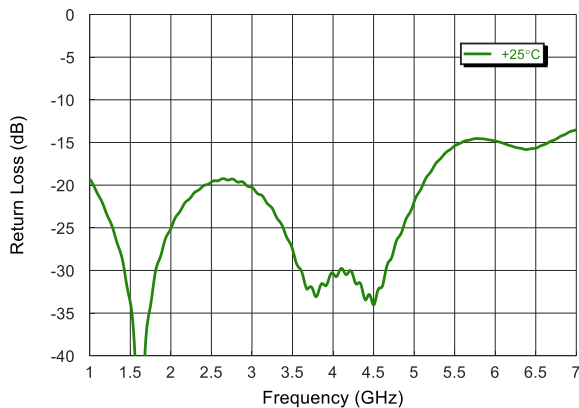

Channel B Wideband LOAD Port Return Loss over swept Frequency in Tx Mode

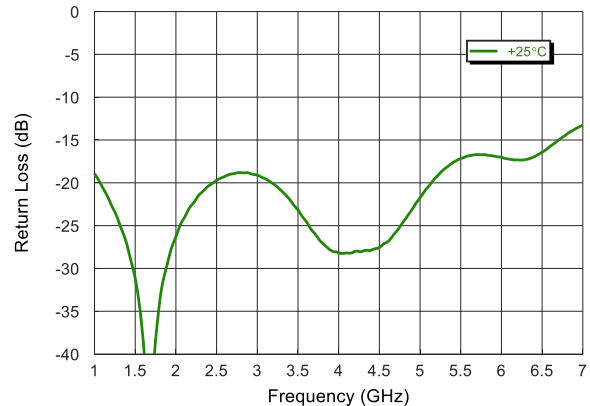

17. For switch insertion loss, RF trace and connector losses are de-embedded

Integrated Dual Channel Switch and LNA Module 2 - 6 GHz



MAMF-011133

Rev. V3

Lead-Free 6 mm 40-Lead QFN[†]

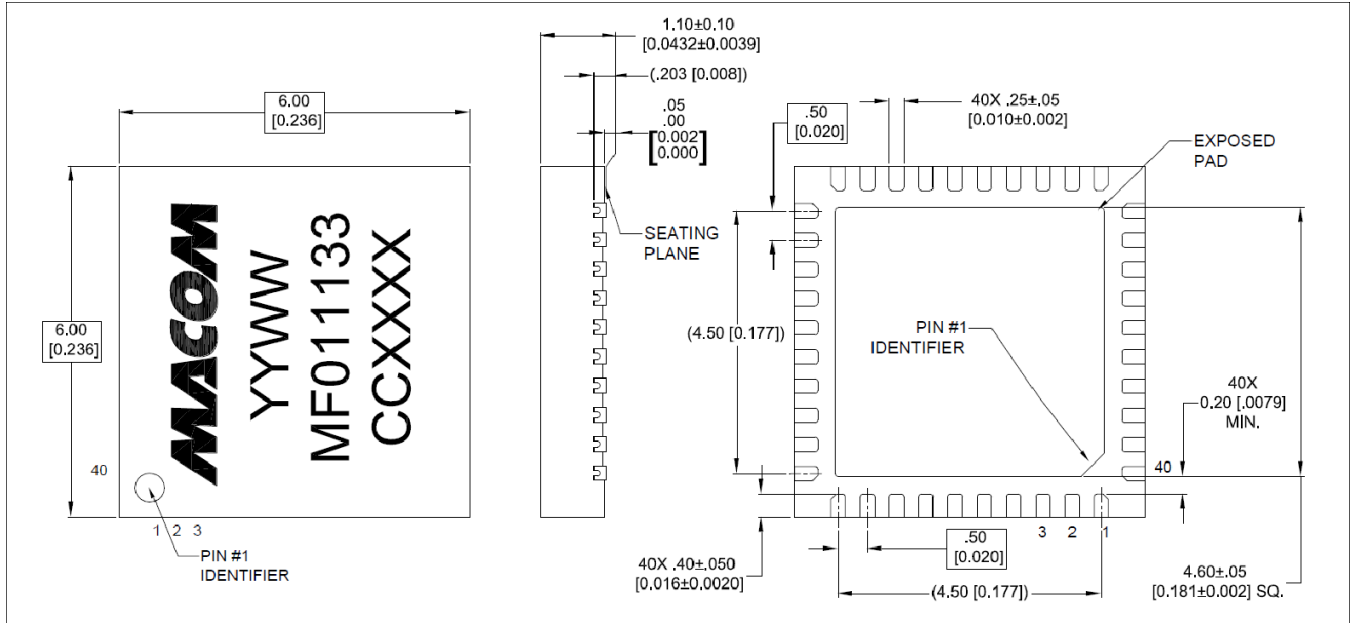

[†] Reference Application Note S2083 for lead-free solder reflow recommendations.
Meets JEDEC moisture sensitivity level 3 requirements.
Plating is NiPdAuAg

Revision History

Rev	Date	Change Description
V1	12/10/20	Initial Release
V2	6/7/21	Added ESD HBM/CDM Ratings
V3	10/18/23	Corrected units on axis of LNA OIP3 and P1dB plots. Replaced wideband Gain & Insertion loss SMB plots with calibrated data. Updated application schematic for enhanced clarity.