

E-Series Surface Mount Mixer 10 - 2500 MHz

Rev. V3

Features

- LO Power +17 dBm
- Up to +13 dBm RF
- Surface Mount
- Wide Frequency Band
- RoHS* Compliant
- Tape and Reel Packaging



Description

The MAMX-009239-001500 is a high drive, surface mount mixer designed for use in high volume wireless applications.

This device is designed to be utilized in both standard reflow and high temperature soldering reflow profiles.

Pin Configuration

Pin No.	Function
1	LO
2, 3	Ground
4	RF
5	IF
6	Ground

Electrical Specifications: RF Freq. = 10 - 2500 MHz, $T_A = 25^\circ\text{C}$, $Z_0 = 50 \Omega$, LO = 17 dBm

Parameter	Test Conditions	Units	Min.	Typ.	Max.
Conversion Loss	Low Range, 10 - 1250 MHz Upper Range, 1250 - 2500 MHz	dB	—	5.5 7.6	7 9
LO-IF Isolation	Low Range, 10 - 1250 MHz Upper Range, 1250 - 2500 MHz	dB	30 23	40 30	—
LO-RF Isolation	Low Range, 10 - 1250 MHz Upper Range, 1250 - 2500 MHz	dB	35 23	40 35	—
IIP3	10 - 2500 MHz	dBm	23	25	31
RF Input for 1 dB Compression	10 - 2500 MHz	dBm	—	—	13

Ordering Information

Part Number	Package
MAMX-009239-001500	900 piece reel

Absolute Maximum Ratings

Parameter	Value
RF Power	50 mW
Peak IF Current	40 mA
Pin Temperature	260°C, 10 seconds
Operating Temperature	-40°C to +85°C
Storage Temperature	-55°C to +125°C

Typical Performance Curves¹

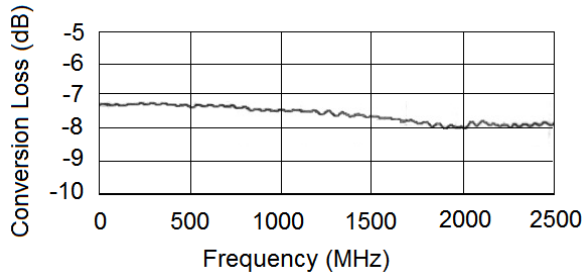

1. Full temperature plots available on request.

Recommended Board Layout

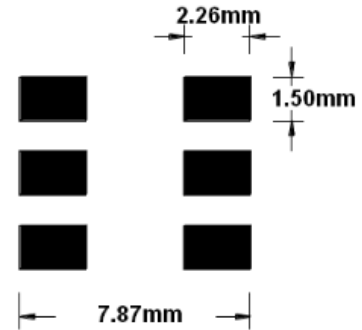

Outline Drawing

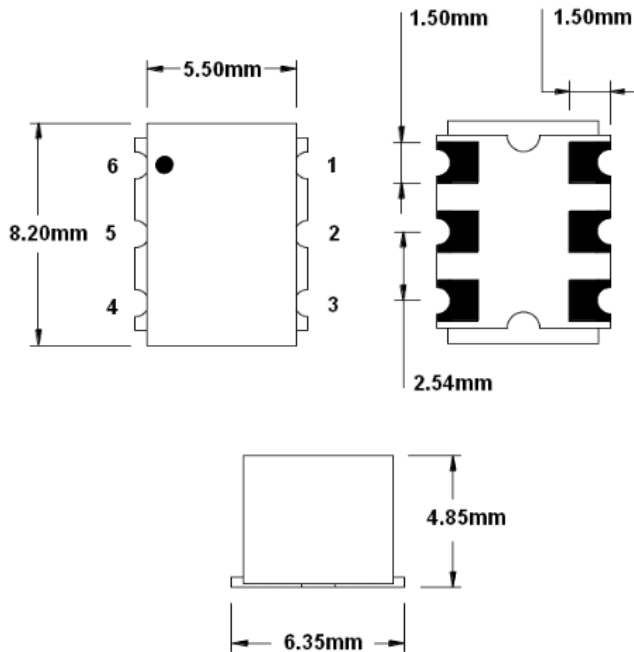

Carrier Tape Orientation

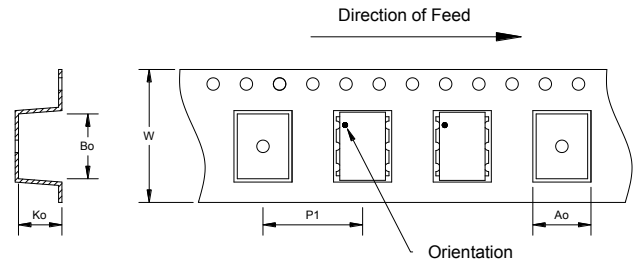

Tape & Reel Information

Parameter	Units	Value
Qty per reel	-	900
Ao	mm	7.00 +/-0.1
Bo	mm	8.60 +/-0.1
Ko	mm	5.23 +/-0.1
W	mm	16.00 +/-0.3
P1	mm	12.00 +/-0.1