

Features

- Small Size, Low Profile
- Superior Repeatability
- Insertion Loss: 1.1 dB Typical
- Isolation: 22 dB Typical
- Low Cost
- Lead-Free SOW-16 Package
- 100% Matte Tin Plating over Copper
- Halogen-Free “Green” Mold Compound
- 260°C Reflow Compatible
- RoHS* Compliant Version of DS56-0002

Description

M/A-COM’s MAPDCC0018 is an IC-based monolithic power divider in a low cost SOW-16 lead free plastic package. This 6-way power divider is ideally suited for applications where small size, low profile and low cost, without sacrificing performance, are required. Typical applications include base stations, portables, and PCMCIA cards for wireless standards such as DCS-1800, PCN, PCS, DECT, and PHS. Available in Tape and Reel.

The MAPDCC0018 is fabricated using a passive-integrated circuit process. The process features full-chip passivation for increased performance and reliability.

Ordering Information

Part Number	Package
MAPDCC0018	Bulk Packaging
MAPDCC0018-TR	1000 piece reel
MAPDCC0018-TB	Sample Test Board

Note: Reference Application Note M513 for reel size information.

Functional Block Diagram¹

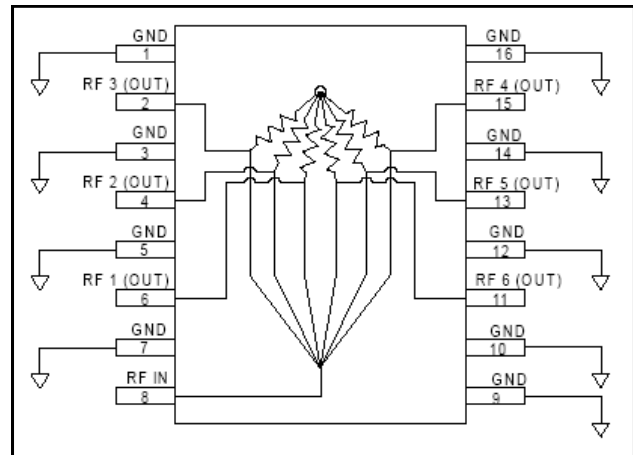

1. Pins 1, 3, 5, 7, 9, 10, 12, 14 and 16 must be DC and RF grounded.

Pin Configuration

Pin No.	Function	Pin No.	Function
1	GND	9	GND
2	RF 3 (OUT)	10	GND
3	GND	11	RF 6 (OUT)
4	RF 2 (OUT)	12	GND
5	GND	13	RF 5 (OUT)
6	RF 1 (OUT)	14	GND
7	GND	15	RF 4 (OUT)
8	RF IN	16	GND

Electrical Specifications: $T_A = 25^\circ\text{C}$, $Z_0 = 50\Omega$

Parameter	Units	Min	Typ	Max
Insertion Loss above 7.8 dB	dB	—	1.2	1.5
Isolation	dB	18	22	—
VSWR	—	—	1.4:1	1.8:1
Amplitude Balance	dB	—	0.5	1.0
Phase Balance	Deg.	—	8	15

Absolute Maximum Ratings ^{2,3}

Parameter	Absolute Maximum
Input Power ⁴	1 W CW
Operating Temperature	-40°C to +85°C
Storage Temperature	-65°C to +150°C

- Exceeding any one or combination of these limits may cause permanent damage to this device.
- M/A-COM does not recommend sustained operation near these survivability limits.
- With internal load dissipation of 0.125 W maximum.

Handling Procedures

Please observe the following precautions to avoid damage:

Static Sensitivity

GMIC Circuits are sensitive to electrostatic discharge (ESD) and can be damaged by static electricity. Proper ESD control techniques should be used when handling these devices.

Recommended PCB Configuration

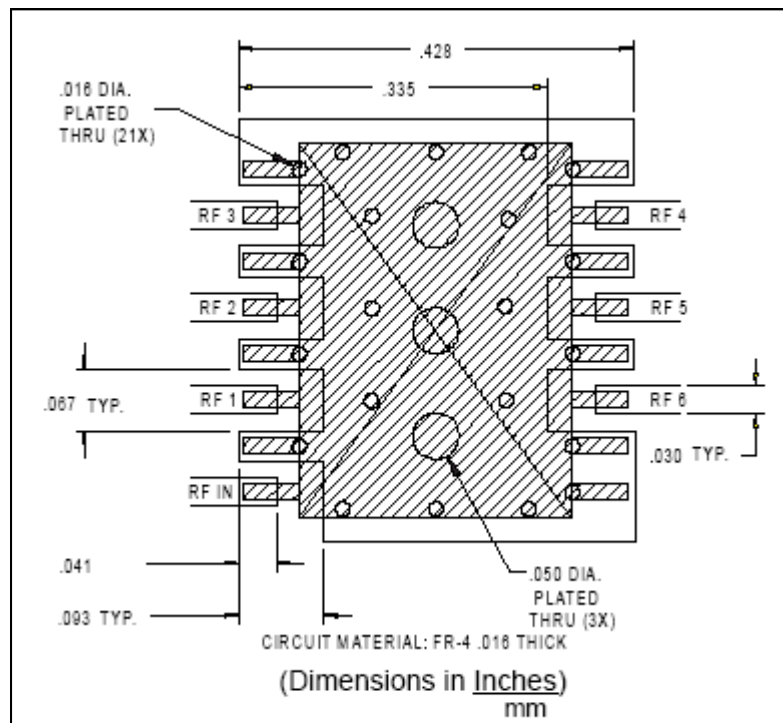

2

M/A-COM Technology Solutions Inc. (MACOM) and its affiliates reserve the right to make changes to the product(s) or information contained herein without notice. Visit www.macom.com for additional data sheets and product information.

Typical Performance Curves

Insertion Loss vs. Frequency

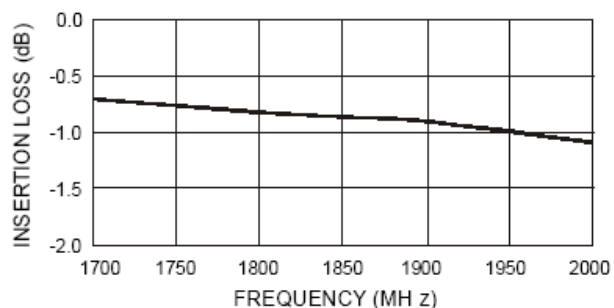

VSWR vs. Frequency

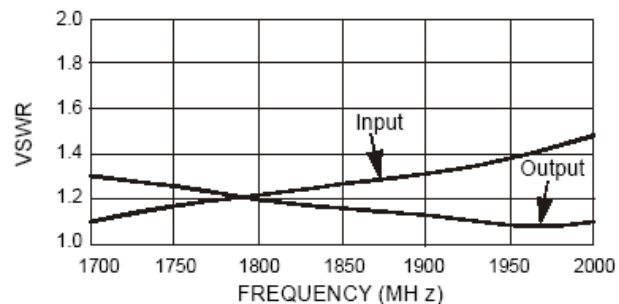

Isolation vs. Frequency

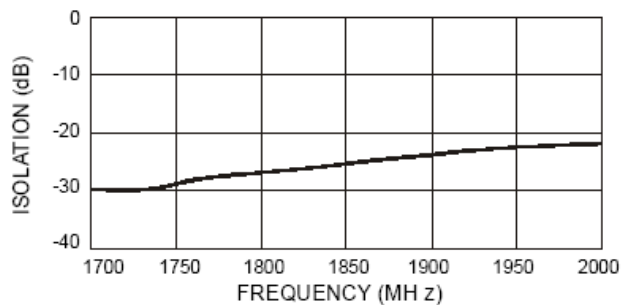

Lead-Free, SOW-16[†]

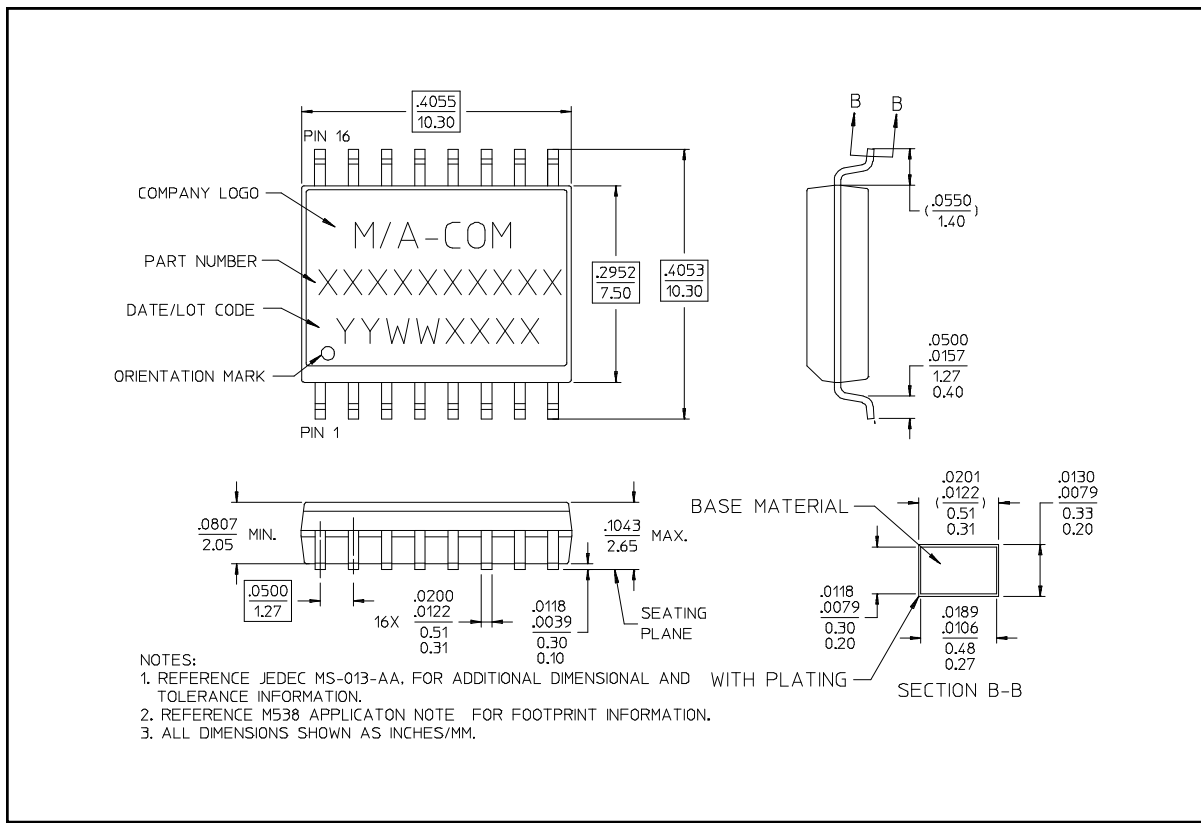

[†] Reference Application Note M538 for lead-free solder reflow recommendations.