

SPDT Switch & Limiter 2.7 - 3.5 GHz

Rev. V4

Features

- 125 W CW T_x Input Power Handling @ +85°C Baseplate
- Integrates SP2T & Limiter Function
- Low T_x and R_x Insertion Loss
- High Isolation on Receive Path
- 10 dBm R_x Flat Leakage
- Operates from +/-5 V & +30 V
- Ultra Fast Recovery Time <100 ns
- Surface Mount 7 mm 32-lead HQFN JEDEC MSL1 Package
- RoHS* Compliant and 260°C Reflow Compatible

Description

The MASL-011023 is a plastic packaged high power switch-limiter with integrated bias networks. This surface mount, small configuration is designed with minimal parasitics usually associated with hybrid MIC designs incorporating beam lead and/or bondable PIN diodes that require chip and wire assembly. This standard HQFN enables reliable, repeatable high volume manufacturing with MACOMs' design techniques to maximize heat dissipation in a plastic package.

This SP2T switch-limiter is designed to optimize Ant to R_x loss and handle +51 dBm CW through the T_x path to an external high power 50 Ω termination. This device incorporates a high power SP2T switch, a limiter function, and a fully integrated RF & DC bias network.

The MASL-011023 is designed to be used in 2.7 - 3.5 GHz higher power switch applications that require high volume, surface mount, solder reflow manufacturing. It is RoHS compliant, durable, reliable and capable of meeting all military, commercial, and industrial environments.

Ordering Information

Part Number	Package
MASL-011023	Bulk Packaging
MASL-011023-TR0500	500 piece reel
MASL-011023-001SMB	Sample Board

Functional Block Diagram

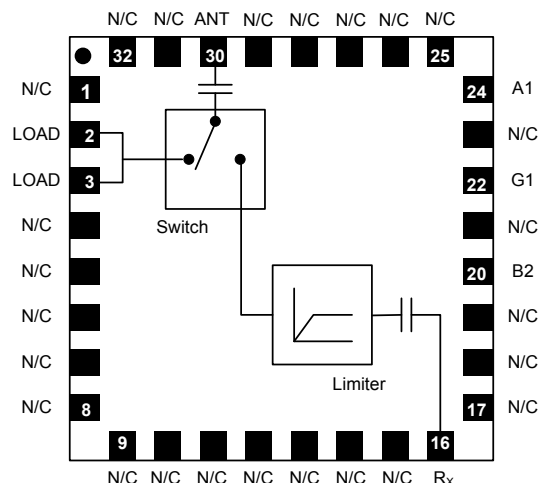

Pin Configuration

Pin #	Pin Name	Description
1	N/C	No Connection
2	LOAD	T _x Port
3	LOAD	T _x Port
4 - 15	N/C	No Connection
16	R _x	R _x Port
17 - 19	N/C	No Connection
20	B2	Bias
21	N/C	No Connection
22	G1	Ground
23	N/C	No Connection
24	A1	No Connection
25 - 29	N/C	No Connection
30	ANT	Antenna
31, 32	N/C	No Connection
33 ¹	Ground Paddle	

1. The exposed pad centered on the package bottom must be connected to RF, DC and thermal ground.

* Restrictions on Hazardous Substances, European Union Directive 2002/95/EC.

SPDT Switch & Limiter 2.7 - 3.5 GHz

Rev. V4

Electrical Specifications: Freq: 2.7 - 3.5 GHz, $T_A = +25^\circ\text{C}$, $P_{IN} = -10\text{ dBm}$, $Z_0 = 50\ \Omega$

Parameter	Condition	Units	Min.	Typ.	Max.
Insertion Loss	R _X Mode	dB	—	0.85	1.5
	T _X Mode 1			0.25	—
Isolation	ANT to T _X Port, R _X Mode ANT to R _X Port, T _X Mode 1	dB	— 25	17 30	—
Return Loss	ANT & R _X ports, R _X Mode	dB	—	14	—
	ANT & T _X ports, T _X Mode 1			14	
CW Input Power, ANT port	T _X Mode 1	dBm	—	51	—
	R _X Mode all Driver Conditions, also un-biased			33 33	
T _X P0.1dB Compression	T _X Mode 1	dBm	—	51	—
Flat Leakage	33 dBm P _{IN} , R _X Mode	dBm	—	10	—
R _X Leakage	51 dBm P _{IN} , T _X Mode 1	dBm	—	7	—
Switching Time ²	50% TTL Control to 90% RF Voltage	ns	—	700	—
Limiter Recovery Time to Final Insertion Loss	P _{IN} <+33 dBm to -10 dBm, 300 μs pulse, 50% duty cycle, R _X Mode	ns	—	<100	—
Spike Leakage	300 μs pulse, 50% duty cycle, R _X Mode	ergs	—	<0.1	—

2. Actual results are driver-dependent.

Absolute Maximum Ratings^{3,4,5}

Parameter	Absolute Maximum
Operating Temperature	-55°C to +85°C
Storage Temperature	-65°C to +150°C
Junction Temperature ⁶	+175°C
Applied Reverse Voltage	100 V
T _X RF CW Incident Power	125 W @ +85°C
T _X Bias Current +25°C	150 mA

- Exceeding any one or combination of these limits may cause permanent damage to this device.
- MACOM does not recommend sustained operation near these survivability limits.
- Operating at nominal conditions with $T_J \leq +175^\circ\text{C}$ will ensure $\text{MTTF} > 1 \times 10^6$ hours.
- T_X path typical thermal resistance (Θ_{jc}) = 12.6° CW dissipated.

Driver Conditions

Control Level DC Voltages (resulting currents) G1 = Ground, A1 = N/C		Condition of RF Output
B3	B1	
-5 V (-35 mA ⁷)	+30 V (132 mA)	T _X Mode 1 R _{RX} = 120 Ω
-5 V (-25 mA ⁷)	+30 V (132 mA)	T _X Mode 2 R _{RX} = 160 Ω
+5 V (+17 mA ⁷)	-5 V (0 mA)	R _{RX} Mode

- Current is controlled externally, with R_{RX} in parallel with a switching diode. "Rcom" is 220 Ω. G1 is connected to ground externally. See Application Circuit Diagram.

Handling Procedures

Please observe the following precautions to avoid damage:

Static Sensitivity

RF Integrated Circuits are sensitive to electrostatic discharge (ESD) and can be damaged by static electricity. Proper ESD control techniques should be used when handling these devices.

Bias Control

Optimal operation is achieved by simultaneous application of positive DC voltage to the low loss switching arm and negative DC voltage to the isolating switching arm.

In the low loss state, the diode is forward biased with current. In the isolated state, the series diode is reverse biased with voltage.

Minimum Reverse Bias Required (T_x mode):
30 V DC Voltage for 125 W CW Power

R. Caverly and G. Hiller, "Establishing the Minimum Reverse Bias for a P-I-N Diode in a High Power Switch," IEEE Transactions on Microwave Theory and Techniques, Vol.38, No.12, December 1990

Application Schematic⁸

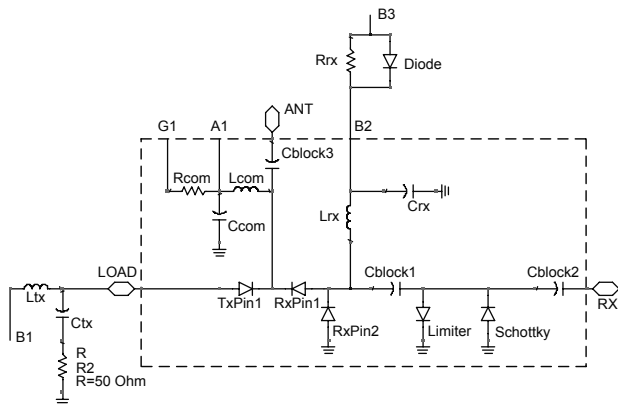

8. MASL-011023 includes components within the rectangle above.

Suggested PCB Layout

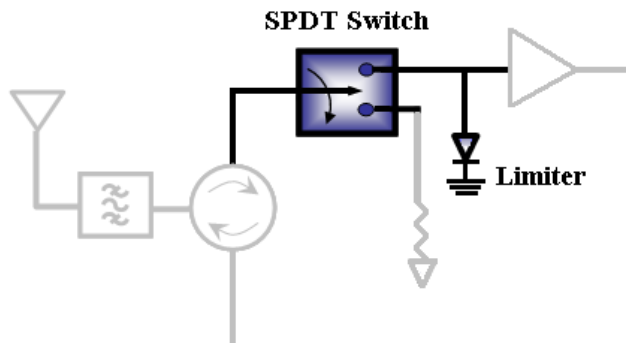
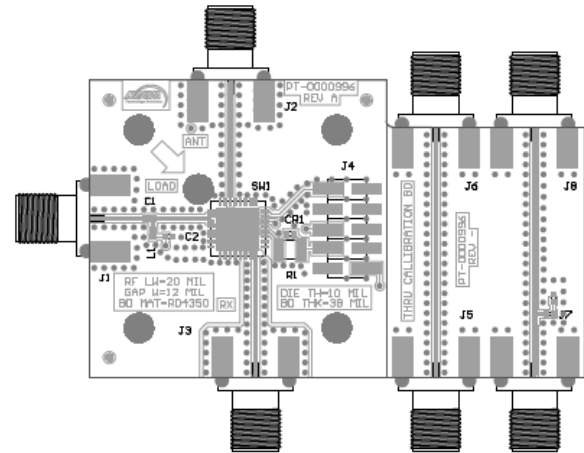

Parts List

Part	Value	Case Style
C1 = CT _x	12 pF	0603, Low ESR ⁹
C2	12 pF	0402
L1 = LT _x	47 nH	0402
Diode = CR1	125 mA/80 V	0402
R1 = RR _x	120 Ω	1210, >=1/2 W

9. Johanson Technology R14S is recommended.

Typical Performance Curves R_x Mode

Insertion Loss

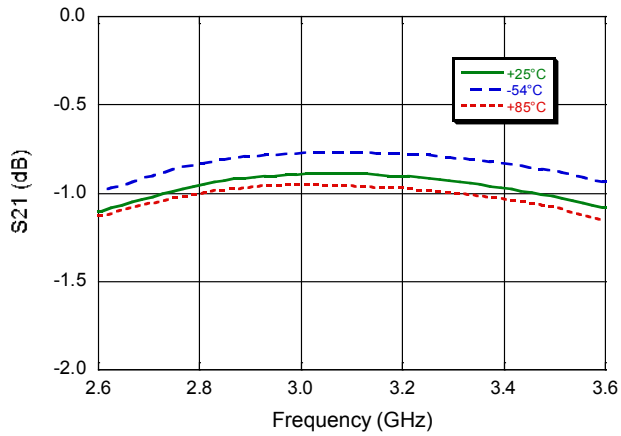

Isolation ANT to T_x Port

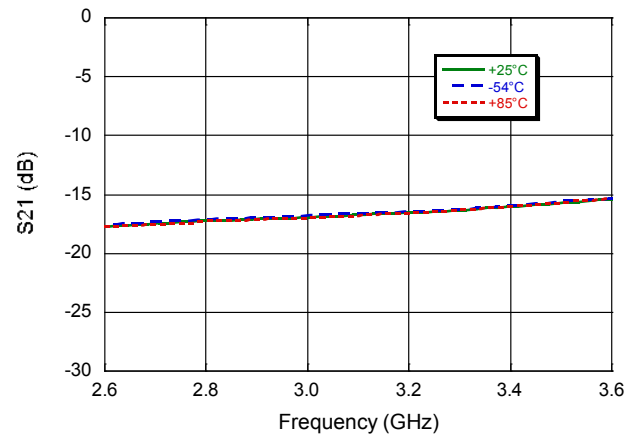

Input Return loss

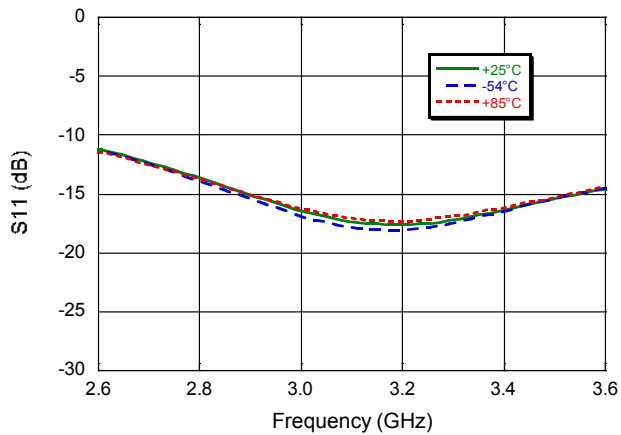

Output Return Loss

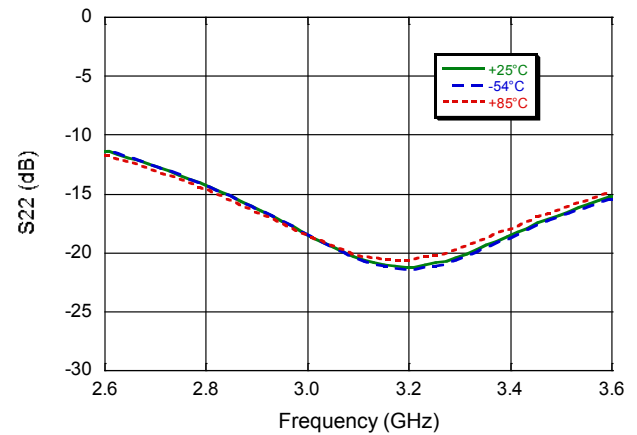

R_x Leakage in R_x Mode

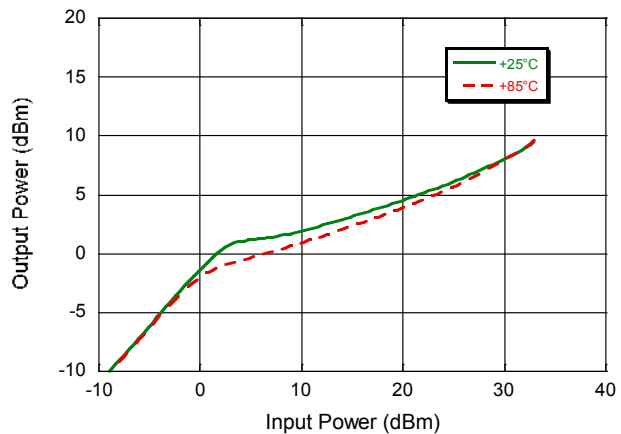

R_x Leakage in T_x Mode

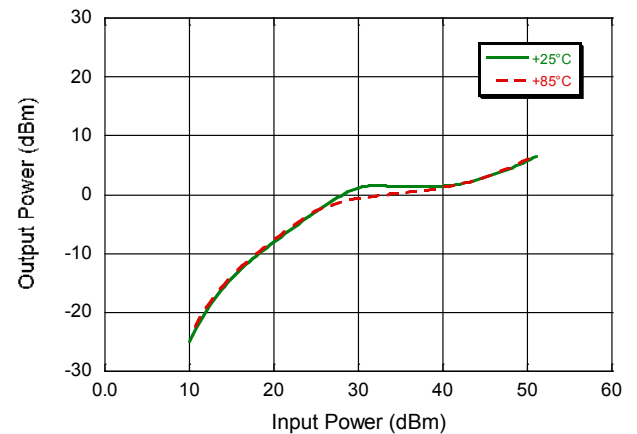

Typical Performance Curves T_x Mode 1

Insertion Loss

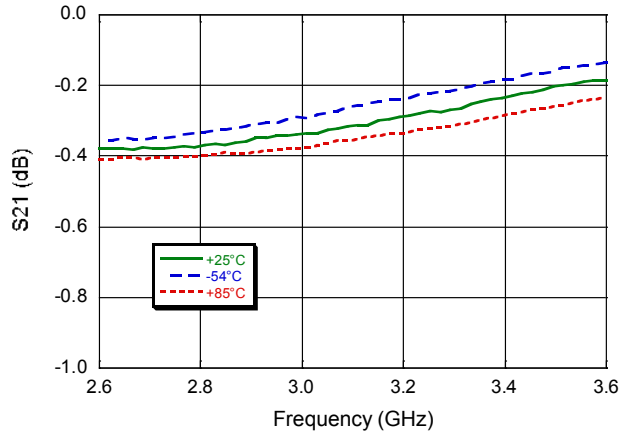

Isolation ANT to R_x Port

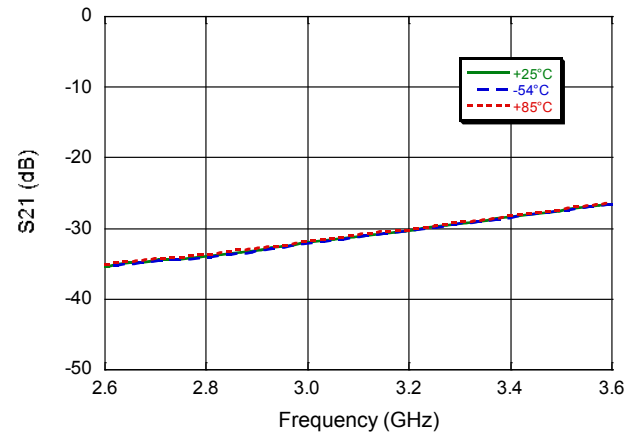

Input Return loss

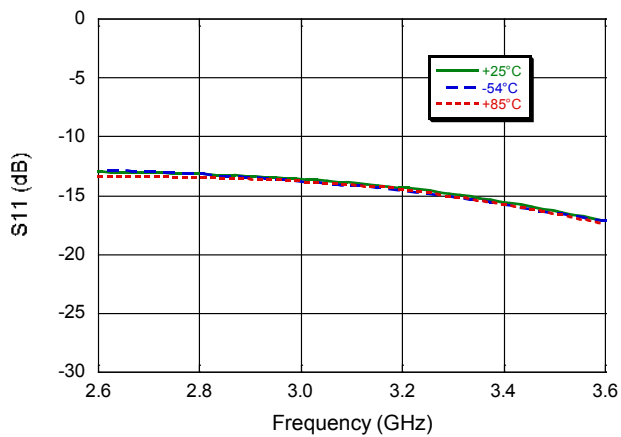

Output Return Loss

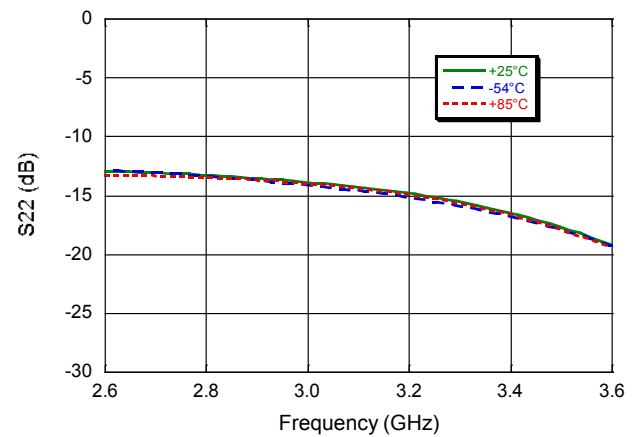

T_x Compression

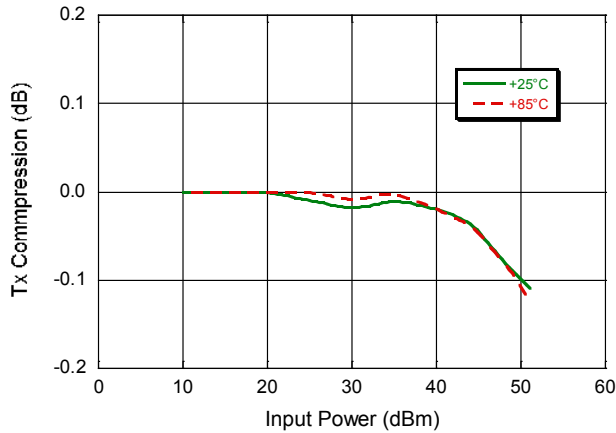

Lead-Free 7 mm 32-Lead HQFN[†]

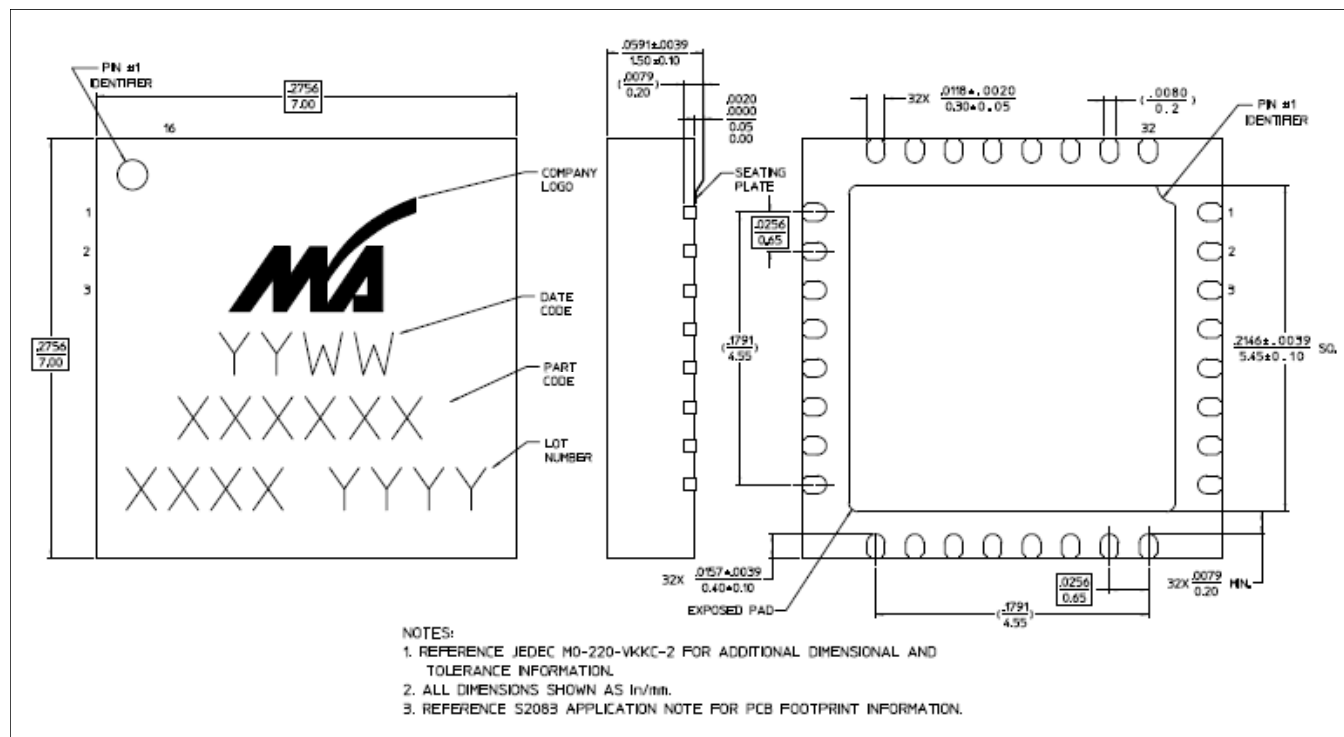

[†] Reference Application Note S2083 for lead-free solder reflow recommendations.
Meets JEDEC moisture sensitivity level 1 requirements.