

Features

- Broad Bandwidth
- Specified from 50 MHz to 20 GHz
- Usable from 50 MHz to 26.5 GHz
- Lower Insertion Loss / Higher Isolation
- Fully Monolithic, Glass Encapsulated Chip
- Up to 33 dBm CW Power Handling @ +25°C
- RoHS* Compliant

Description

The MASW-001100-1190 (SPST), is a series-shunt, broadband, PIN diode die switches made with MACOM's HMIC™ (Heterolithic Microwave Integrated Circuit) process. This process allows the silicon pedestals which form the series-shunt diodes and vias to be embedded into low loss, low dispersion glass. By also incorporating small spacing between circuit elements, the result is an HMIC™ chip with low insertion loss and high isolation at frequencies up to 26.5 GHz.

They are designed for use as moderate power, high performance switches and provide superior performance when compared to similar designs that use discrete components.

The top side of the chip is protected by a polymer coating for manual or automatic handling and large gold bond pads help facilitate connection of low inductance ribbons. The gold metallization on the backside of the chip allows for attachment via 80/20, gold/tin solder or conductive silver epoxy.

Functional Diagrams

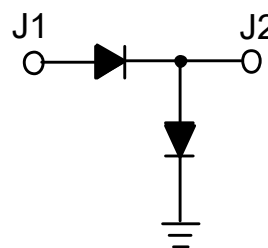
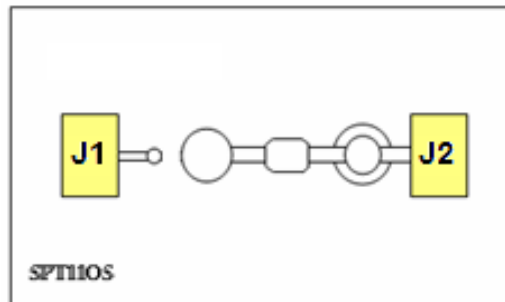

Ordering Information

Part Number	Package
MASW-001100-11900G	Gel Pack
MASW-001100-11900W	Waffle Pack

* Restrictions on Hazardous Substances, compliant to current RoHS EU directive.

Electrical Specifications: $T_A = 25^\circ\text{C}$, 20 mA

Parameter	Test Conditions	Units	Min.	Typ.	Max.
Insertion Loss	6 GHz	dB	—	0.4	0.7
	13 GHz			0.5	0.9
	20 GHz			0.7	1.2
Isolation	6 GHz	dB	46	55	—
	13 GHz		39	47	
	20 GHz		34	42	
Input Return Loss	6 GHz	dB	22	31	—
	13 GHz		15	33	
	20 GHz		14	27	
Switching Speed ¹	—	ns	—	50	—
Voltage Rating ²	—	V	—	—	50
Signal Compression	500 mW, 1 GHz	dB	—	0.2	—

- Typical switching speed is measured from (10% to 90% and 90% to 10% of detected RF voltage), driven by TTL compatible drivers. In the modulating state, (the switching port is modulating, all other ports are in steady state isolation.) The switching speed is measured using an RC network using the following values: R = 50 - 200 Ω , C = 390 - 1000 pF. Driver spike current, $I_C = C dv/dt$, ratio of spike current to steady state current, is typically 10:1.
- Maximum reverse leakage current in either the shunt or series PIN diodes shall be 10 μA maximum at -50 volts.

Absolute Maximum Ratings^{3,4,5}

Parameter	Absolute Maximum
RF CW Incident Power	33 dBm @ +85°C
DC Reverse Voltage	50 V
Bias Current per Port	± 50 mA @ +25°C ± 20 mA @ +85°C
Operating Temperature	-65°C to +125°C
Storage Temperature	-65°C to +150°C
Junction Temperature	+175°C

- Exceeding any one or combination of these limits may cause permanent damage to this device.
- MACOM does not recommend sustained operation near these survivability limits.
- Maximum operating conditions for a combination of RF power, DC bias and temperature: 33 dBm CW @ 15 mA (per diode) @ +85°C.

Handling Procedures

Please observe the following precautions to avoid damage:

Static Sensitivity

These electronic devices are sensitive to electrostatic discharge (ESD) and can be damaged by static electricity. Proper ESD control techniques should be used when handling these Class 0 (HBM) and Class C1 (CDM) devices.

Typical Performance Curves @ 10 GHz

Insertion Loss vs. Bias Current

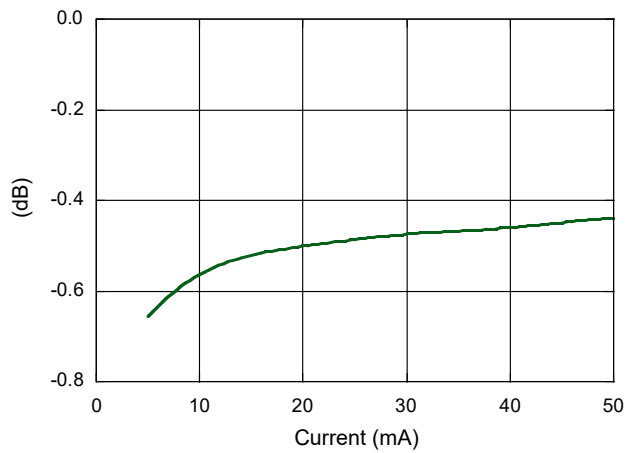

Isolation vs. Bias Current

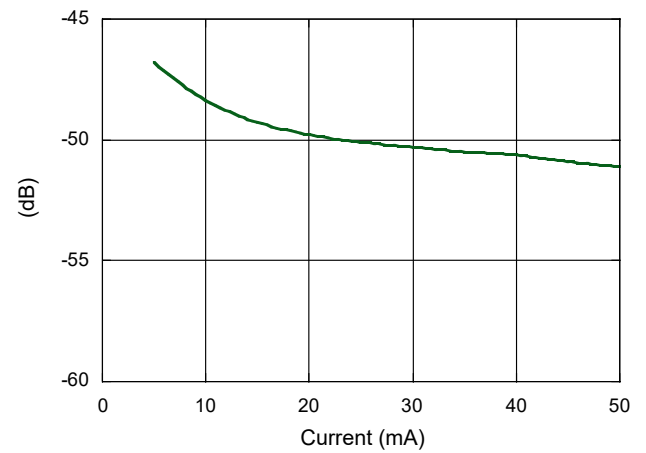

Input Return Loss vs. Bias Current

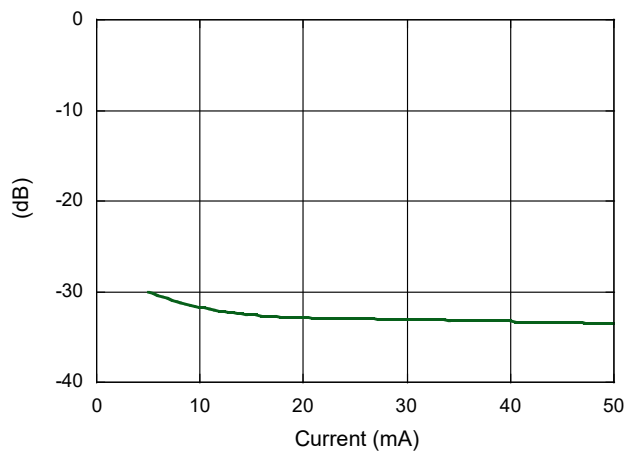

Output Return Loss vs. Bias Current

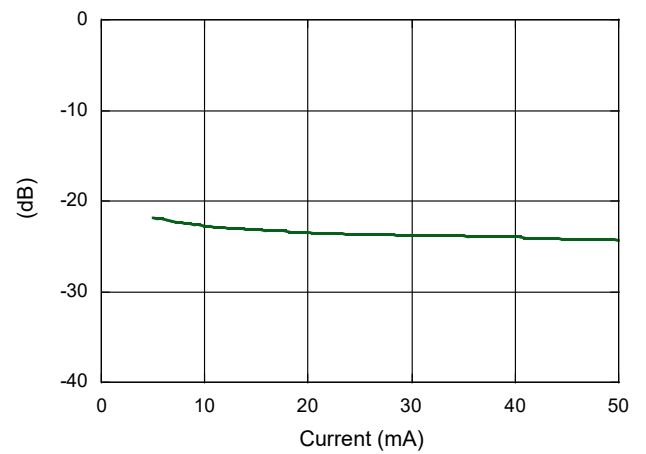

Typical Performance Curves @ $T_A = +25^\circ\text{C}$, 20 mA Bias Current

Isolation vs. Frequency

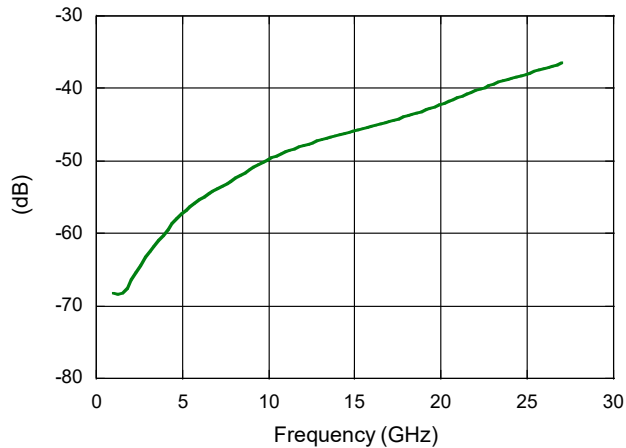

Insertion Loss vs. Frequency

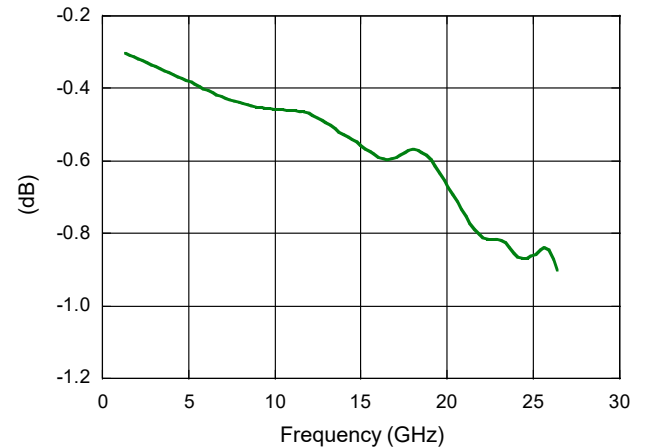

Return Loss vs. Frequency

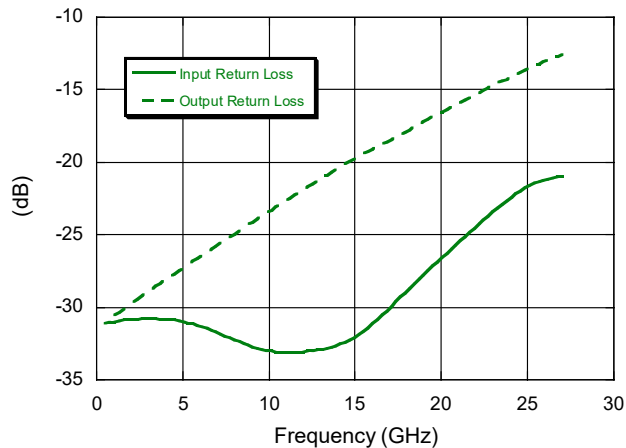

Operation of MASW-001100

The simultaneous application of a negative DC current to the low loss port and positive DC current to the isolated port is required for proper operation of the MASW-001100. The backside area of the die is the RF and DC ground return and the DC return is through the common Port J1. A constant current source should be used to supply the DC control currents. The control voltages at these points will not exceed ± 1.5 V for supply currents up to ± 20 mA. In the low loss state, the series diode must be forward biased and the shunt diode reverse biased. On all isolated ports, the shunt diode is forward biased and the series diode is reverse biased.

Application Schematic with MADR-011022

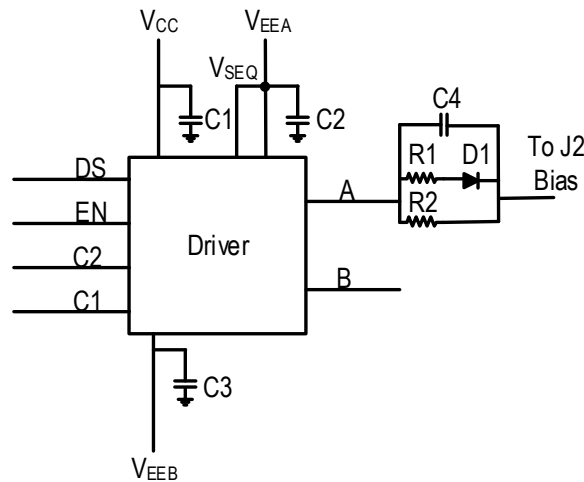

Parts List⁶

Part	Value
C1, C3	0.1 μ F
C2	47 pF
C4	470 pF
R1	270 Ω
R2	390 Ω
R3	560 Ω
D1	1N4148WS

6. Resistor values calculated to provide ~ 20 mA of bias current and ~ -12 V reverse bias voltage at the anode of the shunt diode given $V_{CC} = 5$ V, $V_{EEA} = -20$ V, voltage drop at driver output 0.4 V, V_F of D1 0.7 V and V_F of switch diodes ~ 1 V.

Driver Connections and Drivers

DC Control Current (mA)	RF Output State
J2	J1-J2
-20	low loss
+20	Isolation
Compatible MACOM Driver MADR-007097-000100	

Bias Connections⁷

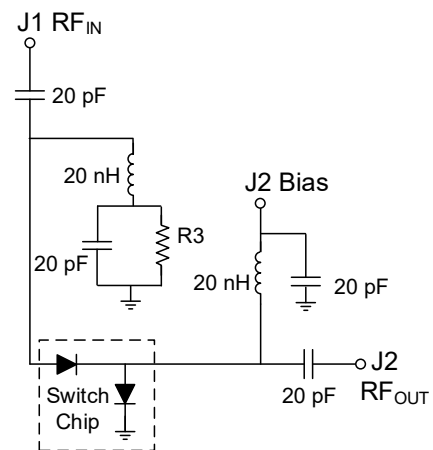

7. RLC values are for an operation frequency of 2-18 GHz and bias current of ± 20 mA per port..

Minimum Reverse Bias Voltage⁸

Frequency (GHz)	DC Voltage (V)
0.05	17
2	12
5	7
10	4
15	3
18	2

8. Minimum DC bias voltage to maintain low loss under 2 W of power with 1.5:1 VSWR.

Cleanliness

The chips should be handled in a clean environment free of dust and organic contamination.

Wire / Ribbon Bonding

Thermo compression wedge bonding using 0.003" x 0.00025" ribbon or 0.001" diameter gold wire is recommended. A work stage temperature of 150°C - 200°C, tool tip temperature of 120°C - 150° and a downward force of 18 to 22 grams should be used. If ultrasonic energy is necessary, it should be adjusted to the minimum level required to achieve a good bond. Excessive power or force will fracture the silicon beneath the bond pad causing it to lift. RF bond wires and ribbons should be kept as short as possible for optimum RF performance.

Chip Mounting

HMIC switches have Ti-Pt-Au backside metallization and can be mounted using a gold-tin eutectic solder or conductive epoxy. Mounting surface must be free of contamination and flat.

Eutectic Die Attachment

80/20, gold-tin, solder is recommended. A re-flow oven or hot gas die bonder with a temperature setting of 290°C is normally used to melt the solder. The chip should not be exposed to temperatures greater than 320°C for more than 20 seconds. Typically no more than three seconds at peak temperature is required for attachment. RoHS compliant solders may also be used but solders rich in tin should be avoided as they will scavenge the backside gold and/or cause gold embrittlement.

Epoxy Die Attachment

A minimum amount of epoxy, 1 - 2 mils thick, should be used to attach chip. A thin epoxy fillet should be visible around the outer perimeter of the chip after placement. Epoxy cure time is typically 1 hour at 150°C.

Outline Drawing^{9,10}

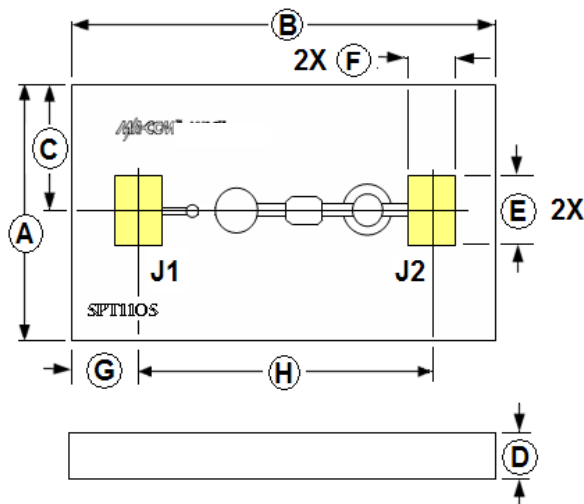

Dim.	Inches		mm	
	Min.	Max.	Min.	Max.
A	0.014	0.018	0.35	0.45
B	0.025	0.029	0.64	0.74
C	0.008 Ref.		0.20 Ref.	
D	0.004	0.006	0.10	0.15
E	0.004 Ref.		0.10 Ref.	
F	0.003 Ref.		0.08 Ref.	
G	0.003 Ref.		0.08 Ref.	
H	0.020 Ref.		0.52 Ref.	

9. Topside and backside metallization is gold, 2.5 μm thick typ.
 10. Yellow areas indicate ribbon/wire bonding pads.