

## Features

- Operates DC - 4 GHz on Single Supply
- ASIC TTL / CMOS Driver
- Low DC Power Consumption
- 50 Ohm Nominal Impedance
- Test Boards are Available
- Tape and Reel are Available
- Lead-Free 4 x 6 mm PQFN Package
- 100% Matte Tin Plating over Copper
- Halogen-Free "Green" Mold Compound
- 260°C Reflow Compatible
- RoHS\* Compliant Version of SW90-0002

## Description

M/A-COM's MASW-007071-000100 is a SPDT absorptive pHEMT switch with integral TTL driver. This device is in an PQFN plastic surface mount package. This switch offers excellent broadband performance and repeatability from DC to 4 GHz, while maintaining low DC power dissipation. The MASW-007071-000100 is ideally suited for wireless infrastructure applications.

## Ordering Information

Part Number	Package
MASW-007071-000100	Bulk Packaging
MASW-007071-0001TR	1000 piece reel
MASW-007071-0001TB	Sample Test Board

Note: Reference Application Note M513 for reel size information.

## Pin Configuration<sup>1,2,3,4</sup>

Pin No.	Function	Pin No.	Function
1	NC	17	NC
2	GND	18	C1
3	RFC	19	NC
4	GND	20	V <sub>CC</sub>
5	NC	21	NC
6	NC	22	NC
7	GND	23	CP1
8	RF1	24	CP2
9	GND	25	NC
10	NC	26	V <sub>EE</sub>
11	NC	27	NC
12	V <sub>EE</sub>	28	NC
13	NC	29	NC
14	V <sub>CC</sub>	30	GND
15	NC	31	RF2
16	NC	32	GND

1. NC = No Connection
2. V<sub>EE</sub> is internally generated and must remain isolated from external power supplies. Generated noise is typical of switching DC-DC Converters.
3. Connections and external components shown in functional schematic are required. 0.1 μF Capacitors need to be located near pins 20 & 26.
4. The exposed pad centered on the package bottom must be connected to RF and DC ground. (For PQFN Packages)

## Truth Table (Switch)

Control Input	Condition of the Switch	
	RF Common to each RF Port	
	RF1	RF2
0	Off	On
1	On	Off

"0" = TTL Low      "1" = TTL High

<sup>1</sup> \* Restrictions on Hazardous Substances, European Union Directive 2002/95/EC.

**Electrical Specifications:  $T_A = 25^\circ\text{C}$ ,  $Z_0 = 50\Omega$**

Parameter	Test Conditions	Frequency	Units	Min	Typ	Max
Insertion Loss	RFC—RF1,RF2 (Logic per truth table)	DC - 4.0 GHz	dB	—	—	1.8
Isolation	RF1—RF2 (All Logic "0")	DC - 4.0 GHz	dB	30	—	—
VSWR	On (RFC,RF1, RF2) (Logic per truth table)	DC - 4.0 GHz	Ratio	—	—	2.0:1
VSWR	Off (RF1, RF2) (Logic per truth table)	DC - 4.0 GHz	Ratio	—	—	1.8:1
1 dB Compression	— —	50 MHz 0.5 - 4.0 GHz	dBm dBm	— —	18 29	— —
Input $IP_3$	Two-tone inputs up to +5 dBm	50 MHz 0.5 - 4.0 GHz	dBm dBm	— —	36 46	— —
Switching Speed	Ton (50% Control to 10% RF)	—	ns	—	31	—
	Toff (50% Control to 90% RF)	—	ns	—	19	—
	Trise (10% to 90% RF)	—	ns	—	6	—
	Tfall (90% to 10% RF)	—	ns	—	2	—
Vcc	—	—	V	4.5	5.0	5.5
$V_{IL}$ $V_{IH}$	LOW-level input voltage	—	V	0.0	—	0.8
	HIGH-level input voltage	—	V	2.0	—	5.0
lin (Input Leakage Current)	$V_{in} = V_{CC}$ or GND	—	uA	-1.0	—	1.0
$I_{cc}^5$	Vcc min to max, Logic "0" or "1"	—	mA	—	5	8
Turn-on Current <sup>6</sup>	For guaranteed start-up	—	mA	—	—	125
$\Delta I_{cc}$ (Additional Supply Current Per TTL Input Pin)	$V_{CC} = \text{Max}$ , $V_{cntrl} = V_{CC} - 2.1 \text{ V}$	—	mA	—	—	1.0
Switching Noise	Generated from DC-DC Converter with recommended capacitors	3.5 MHz	dBm	—	-93	—
Thermal Resistance $\theta_{jc}$	—	—	$^\circ\text{C/W}$	—	15	—

5. During turn-on, the device requires an initial start up current ( $I_{cc}$ ) specified as "Turn-on Current". Once operational,  $I_{cc}$  will drop to the specified levels.
6. The DC-DC converter is guaranteed to start in 100  $\mu\text{s}$  as long as the power supplies have the maximum turn-on current available for start-up.

## GaAs SPDT Switch, Absorptive, Single Supply, DC-4.0 GHz

Rev. V4

### Absolute Maximum Ratings<sup>7,8</sup>

Parameter	Absolute Maximum
Max. Input Power 0.05 GHz 0.5 - 4.0 GHz <sup>9</sup>	+27 dBm +34 dBm
V <sub>CC</sub>	-0.5V ≤ V <sub>CC</sub> ≤ +6.0V
V <sub>in</sub> <sup>10</sup>	-0.5V ≤ V <sub>in</sub> ≤ V <sub>CC</sub> + 0.5V
Operating Temperature	-40°C to +85°C
Storage Temperature	-65°C to +125°C

7. Exceeding any one or combination of these limits may cause permanent damage to this device.
8. M/A-COM does not recommend sustained operation near these survivability limits.
9. When the RF input is applied to the terminated port, the absolute maximum power is +30 dBm.
10. Standard CMOS TTL interface, latch-up will occur if logic signal is applied prior to power supply.

### Handling Procedures

Please observe the following precautions to avoid damage:

### Static Sensitivity

Gallium Arsenide Integrated Circuits are sensitive to electrostatic discharge (ESD) and can be damaged by static electricity. Proper ESD control techniques should be used when handling these devices.

### Moisture Sensitivity

The MSL rating for this part is defined as Level 2 per IPC/JEDEC J-STD-020. Parts shall be stored and/or baked as required for MSL Level 2 parts.

### Recommended PCB Configuration<sup>11</sup>

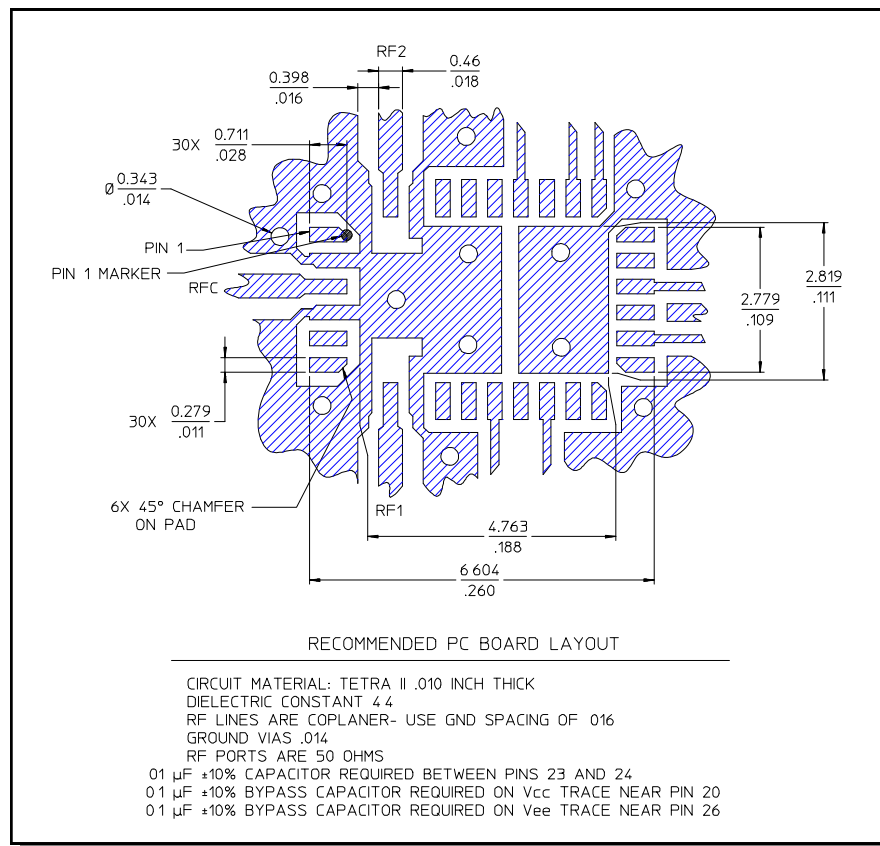

3 11. Application Note S2083 is available on line at [www.macom.com](http://www.macom.com)

M/A-COM Technology Solutions Inc. (MACOM) and its affiliates reserve the right to make changes to the product(s) or information contained herein without notice. Visit [www.macom.com](http://www.macom.com) for additional data sheets and product information.

For further information and support please visit:  
<https://www.macom.com/support>

## Functional Schematic<sup>12</sup>

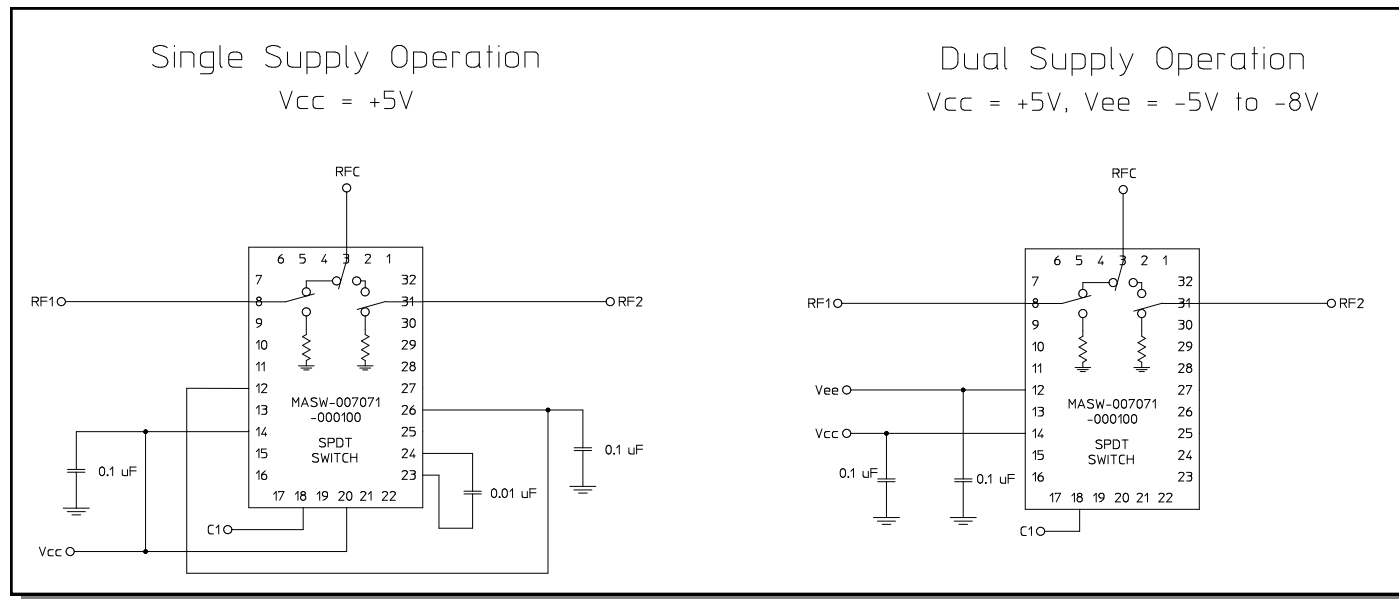

12. Dual Supply Operation will eliminate the start-up current mentioned in Note 5. It will also eliminate spurious signals caused by the DC-DC converter that are present in single supply operation.

## Typical Performance Curves

*Insertion Loss vs. Frequency*

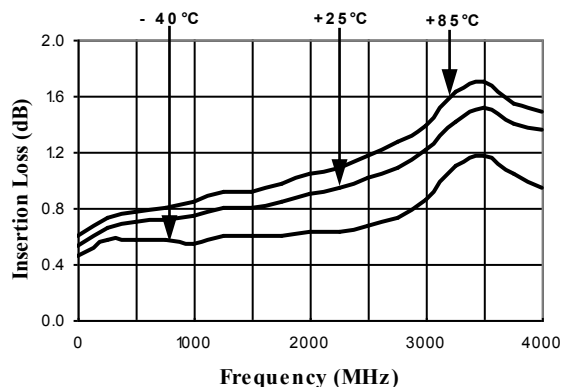

*Isolation (dB) vs. Frequency*

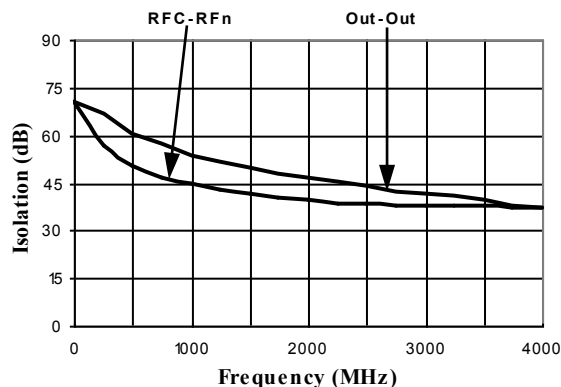

## GaAs SPDT Switch, Absorptive, Single Supply, DC-4.0 GHz

Rev. V4

### Typical Performance Curves

On VSWR vs. Frequency

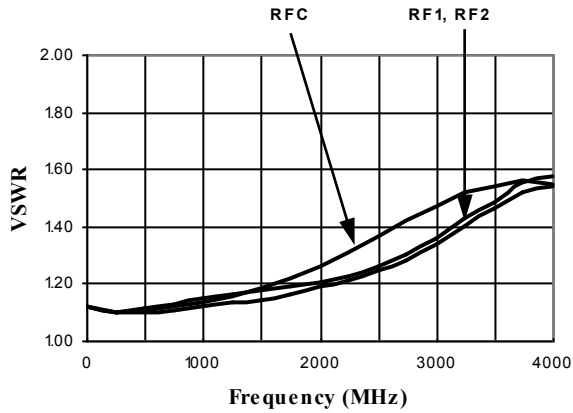

VSWR (Terminations) vs. Frequency

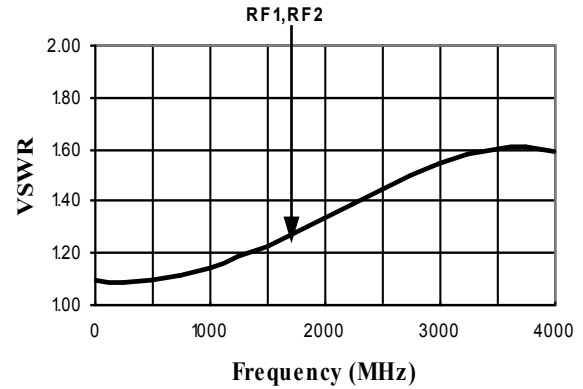

### CSP-1, Lead-Free 4 x 6 mm, 32-lead PQFN<sup>†</sup>

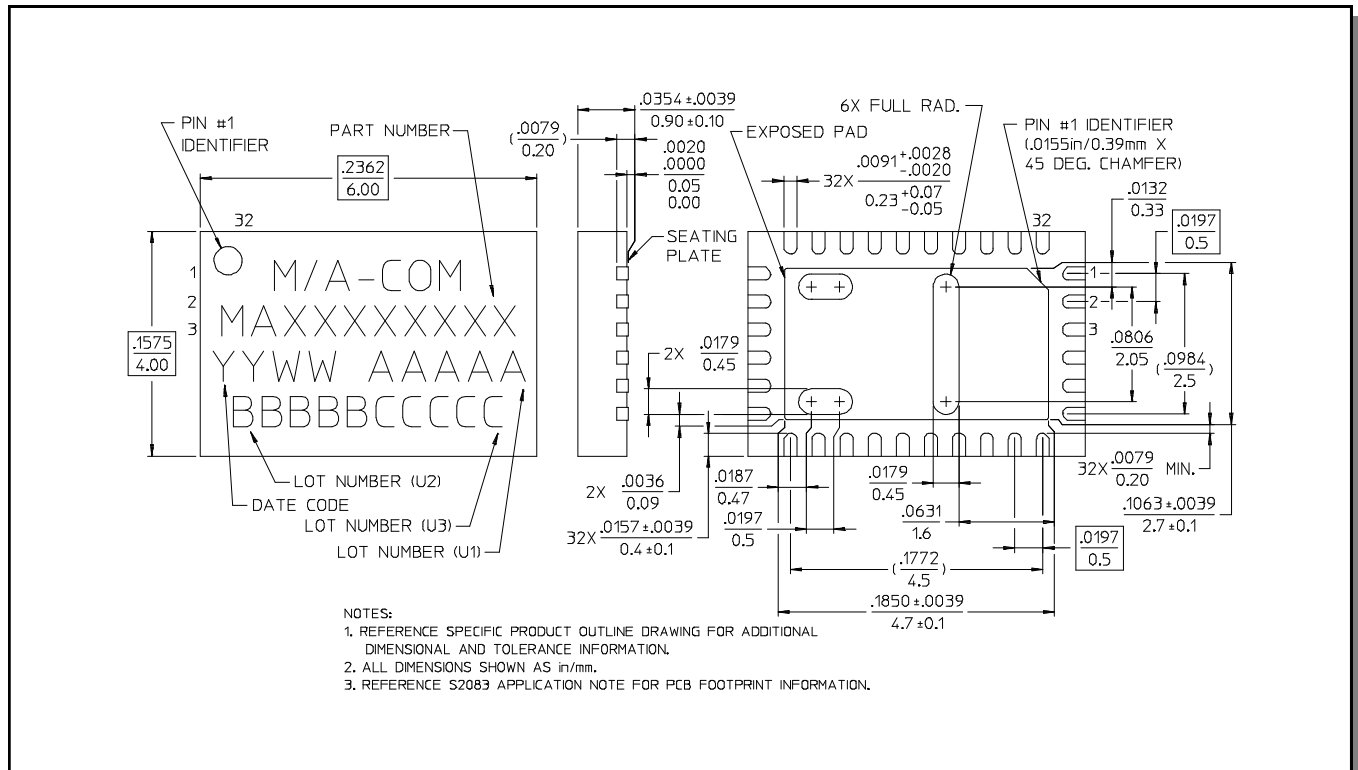

<sup>†</sup> Reference Application Note M538 for lead-free solder reflow recommendations.