

Features

- 200 W CW Incident Power @ +85°C
- Low Insertion Loss: <0.5 dB
- High Isolation: >40 dB
- Harmonics: <-70 dBc
- Operates from +V DC Bias Only
- Lead-Free 9 mm HQFN 20-lead Package
- Halogen-Free “Green” Mold Compound
- RoHS* Compliant and 260°C Reflow Compatible

Description

The MASW-011041 is a high power PIN diode SP3T switch in a common anode configuration, operating from 50 MHz to 1 GHz. It features low insertion loss and excellent linearity. It includes two high-power ports capable of handling up to 200 Watts CW and one low-power port capable of handling up to 100 Watts CW of incident power at a base plate temperature of +85°C.

This high power switch is ideal for use on land mobile radio and MIL-COM applications that require higher CW and pulsed power operation. This device can operate with positive-only DC supplies, making it suitable for switch-filter and power amplifier control circuits.

The MASW-011041 is manufactured using MACOM’s hybrid manufacturing process featuring high voltage PIN diodes and passive devices integrated in a 9 mm HQFN 20-lead plastic package.

The MASW-011041 is compatible with MACOM’s MADR-010574 PIN Diode Driver.

Ordering Information¹

Part Number	Package
MASW-011041-TR0500	500 pc reel
MASW-011041-001SMB	Sample Test Board

1. Reference Application Note M513 for reel size information.

*Restrictions on Hazardous Substances, European Union Directive 2011/65/EU.

Functional Schematic

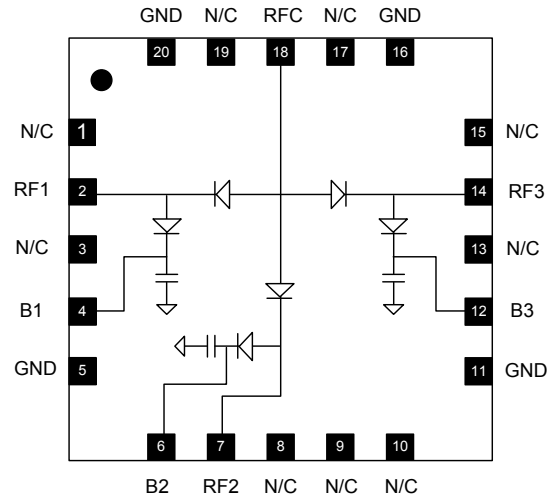

Pin Configuration

Pin	Function	Pin	Function
1	No Connection	11	Ground
2 ²	RF1 Input / V1 Bias	12	B3 Bias
3	No Connection	13	No Connection
4	B1 Bias	14 ²	RF3 Input / V3 Bias
5	Ground	15	No Connection
6	B2 Bias	16	Ground
7 ²	RF2 Input / V2 Bias	17	No Connection
8	No Connection	18	RF Common / V4 Bias
9	No Connection	19	No Connection
10	No Connection	20	Ground
		Paddle ³	Ground

2. RF1 and RF3 are high power ports (200 W); RF2 is a low power port (100 W).

3. The exposed paddle centered on the package bottom must be connected to RF, DC and thermal ground.

**Electrical Specifications: $T_A = 25^\circ\text{C}$, $P_{IN} = 0 \text{ dBm}$ (unless otherwise defined), $Z_0 = 50 \Omega$
Bias⁴ = 5 V / 400 mA, 3 V / 200 mA, 100 V / 25 mA**

Parameter	Test Conditions	Units	Min.	Typ.	Max.
Insertion Loss RFC - RF1 & RFC - RF3	0.5 GHz 1.0 GHz	dB	—	0.30 0.40	— 0.60
Insertion Loss RFC - RF2	0.5 GHz 1.0 GHz	dB	—	0.25 0.40	— 0.55
Isolation RFC - RF1 & RFC - RF3	0.5 GHz 1.0 GHz	dB	— 40	51 45	—
Isolation RFC - RF2	0.5 GHz 1.0 GHz	dB	— 45	56 52	—
Input Return Loss RFC - RF1 & RFC - RF3	$P_{IN} = 0 \text{ dBm}$	dB	—	>14	—
Input Return Loss RFC - RF2	$P_{IN} = 0 \text{ dBm}$	dB	—	>21	—
CW Input Power RFC - RF1 & RFC - RF3	85°C base plate, 550 MHz 950 MHz	dBm / W	—	53 / 200 52 / 158	—
CW Input Power RFC - RF2	85°C base plate, 550 MHz 950 MHz	dBm / W	—	50 / 100 49 / 80	—
P0.1dB RFC - RF1 & RFC - RF3	85°C base plate, 550 MHz 950 MHz	dBm	—	54 53	—
P0.1dB RFC - RF2	85°C base plate, 550 MHz 950 MHz	dBm	—	51 50	—
2nd Harmonics	$P_{IN} = 49 \text{ dBm}$, F = 950 MHz	dBc	—	-75	—
3rd Harmonics	$P_{IN} = 49 \text{ dBm}$, F = 950 MHz	dBc	—	-85	—
T_{ON} , T_{OFF}	(50% CTL - 90% RF and 10% RF) 1 MHz Rep Rate in Modulating Mode	μs	—	3.5	—
T_{RISE} , T_{FALL}	(10-90% RF Voltage) 1 MHz Rep Rate in Modulating Mode	μs	—	0.8	—

4. See Bias table.

Bias Table⁵

RF State	V1 Bias (V)	V2 Bias (V)	V3 Bias (V)	V4 Bias (V)	B1 Bias (V)	B2 Bias (V)	B3 Bias (V)
RFC - RF1 Low Loss RFC - RF2 Isolation RFC - RF3 Isolation	0 V @ 400 mA	100 V @ 25 mA	100 V @ 25 mA	5 V @ 400 mA	100 V @ 0 mA	0 V @ 25 mA	0 V @ 25 mA
RFC - RF2 Low Loss RFC - RF1 Isolation RFC - RF3 Isolation	100 V @ 25 mA	0 V @ 200 mA	100 V @ 25 mA	3 V @ 200 mA	0 V @ 25 mA	100 V @ 0 mA	0 V @ 25 mA
RFC - RF3 Low Loss RFC - RF1 Isolation RFC - RF2 Isolation	100 V @ 25 mA	100 V @ 25 mA	0 V @ 400 mA	5 V @ 400 mA	0 V @ 25 mA	0 V @ 25 mA	100 V @ 0 mA

5. DC reverse bias of a PIN diode operating at a high power is dependent on RF frequency, incident power, and VSWR. See Minimum Reverse DC Voltage table for high power operation.

Absolute Maximum Ratings^{6,7}

Parameter	Absolute Maximum
Forward Current	+400 mA
Reverse DC Voltage	-150 V
Operating Temperature	-55°C to +85°C
Storage Temperature	-65°C to +150°C
Junction Temperature	+175°C

6. Exceeding any one or combination of these limits may cause permanent damage to this device.
7. MACOM does not recommend sustained operation near these survivability limits.

Minimum Reverse DC Voltage⁸

Frequency (MHz)	Minimum Reverse DC Voltage
50	-142 V
100	-102 V
200	-60 V
500	-26 V
1000	-13 V

8. Required to maintain low loss under 200 W of incident power with 1.5:1 VSWR.

Typical Performance Curves:

Insertion Loss

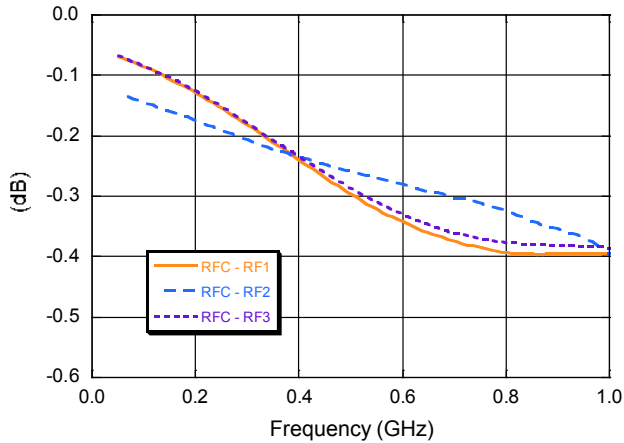

Return Loss

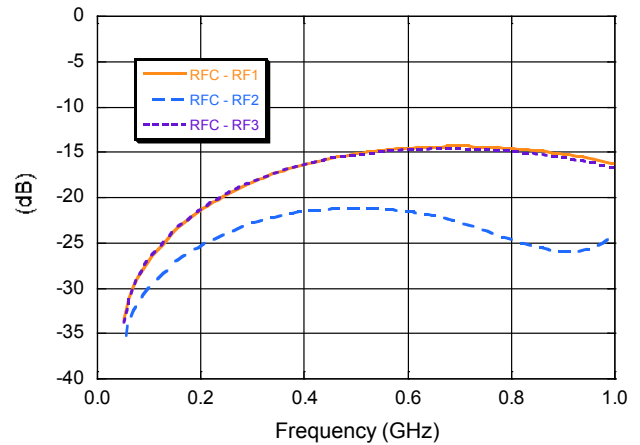

Isolation RFC - RF1

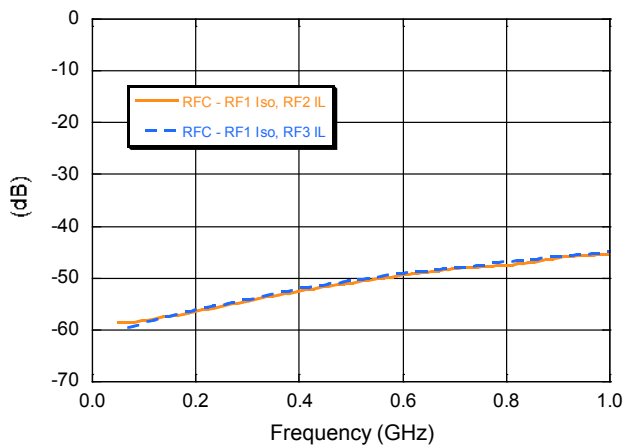

Isolation RFC - RF2

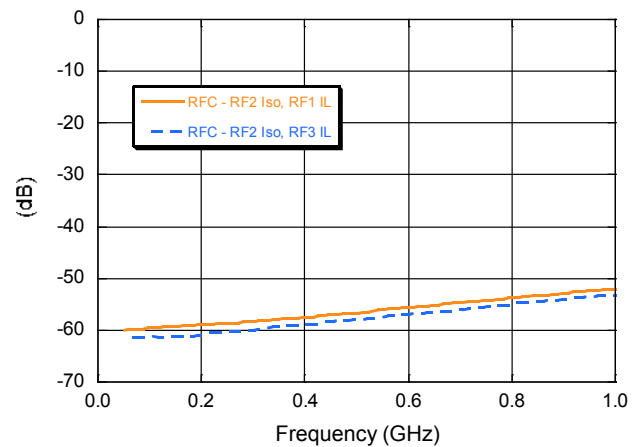

Isolation RFC - RF3

