

AlGaAs SP3T Switch with Integrated Bias Network 2 - 22 GHz



MASW-011130-DIE

Rev. V1

Features

- Broad Bandwidth Specified up to 22 GHz
- Integrated DC Blocks and RF Bias Networks
- Low Insertion Loss / High Isolation
- Fast Switching Speed
- Fully Monolithic
- Low Current Consumption:
-10 mA for Low Loss State
+10 mA for Isolation State
- Die Size: 1.86 x 1.86 mm
- RoHS* Compliant

Applications

- Test & Measurement
- Broadband Communication Systems

Description

The MASW-011130 is an SP3T PIN diode switch with integrated bias networks offered as bare die part. This broadband, reflective switch operates from 2 - 22 GHz and provides less than 1 dB insertion loss and 35 dB isolation.

The combination of broadband performance along with very fast switching (<10 ns) and excellent settling time make this device ideal for many applications, including Test & Measurement, and broadband communication systems.

The switch is fully passivated with silicon nitride and has an added polymer layer for scratch protection. The protective coating prevents damage to the junctions and the anode air-bridges during handling and assembly. The die has backside metallization to facilitate an epoxy die attach process.

Functional Schematic

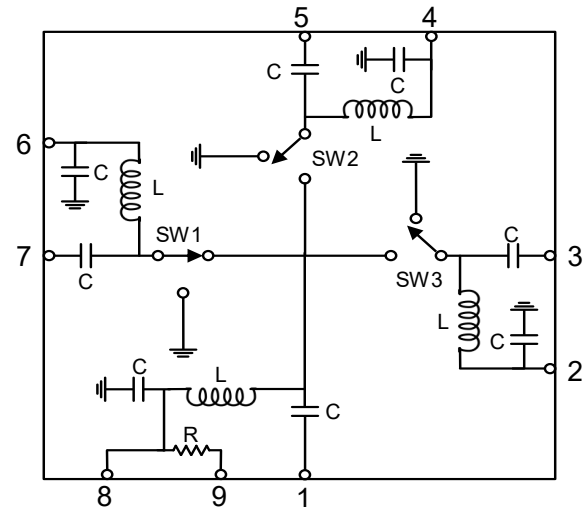

Pad Configuration

Pad #	Function
1	RF Common
2	Bias 3
3	RF3
4	Bias 2
5	RF2
6	Bias 1
7	RF1
8	RF Common Bias (optional external Resistor)
9	RF Common Bias

Ordering Information

Part Number	Package
MASW-011130-DIE	Die in Gel Pack

1 * Restrictions on Hazardous Substances, compliant to current RoHS EU directive.

AlGaAs SP3T Switch with Integrated Bias Network

2 - 22 GHz



MASW-011130-DIE

Rev. V1

Electrical Specifications: $T_A = +25^\circ\text{C}$, $I_{DC} = +/-10\text{ mA}$, $Z_0 = 50\ \Omega$

Parameter	Test Conditions	Units	Min.	Typ.	Max.
Insertion Loss	2 GHz	dB	-1.6	-1.0	-0.4
	6 GHz		-1.0	-0.5	0
	12 GHz		-1.0	-0.5	0
	18 GHz		-1.2	-0.7	-0.2
Input to Output Isolation	2 GHz	dB	—	-60	-50
	6 GHz		—	-50	-40
	12 GHz		—	-45	-35
	18 GHz		—	-40	-30
RF Common Return Loss	2 GHz	dB	—	-16	-12
	6 GHz		—	-20	-16
	12 GHz		—	-24	-20
	18 GHz		—	-21	-17
Output Return Loss	2 GHz	dB	—	-15	-11
	6 GHz		—	-20	-16
	12 GHz		—	-23	-19
	18 GHz		—	-19	-15
P_{IN} at 0.1 dB Compression	$V_R = -2\text{ V}$, @ 2 GHz $V_R = -5\text{ V}$, @ 2 GHz $V_R = -10\text{ V}$, @ 2 GHz	dBm	—	23 28 29	—
Input IP3	2 Tone, 5 dBm/Tone, 5 MHz spacing, 2 - 18 GHz	dBm	—	45	—
T_{RISE} , T_{FALL}	10% to 90% RF and 90% to 10% RF	ns	—	3	—
T_{ON} , T_{OFF}	50% control to 90% RF and 50% control to 10% RF	ns	—	7	—

Absolute Maximum Ratings^{1,2}

Parameter	Absolute Maximum
Incident C.W. RF Power	33 dBm @ $V_R = -10\text{ V}$
Bias Current	$\pm 20\text{ mA}$
Reverse DC Bias Voltage	-50 V
Junction Temperature ³	+150°C
Operating Temperature	-40°C to +85°C
Storage Temperature	-65°C to +150°C

- Exceeding any one or combination of these limits may cause permanent damage to this device.
- MACOM does not recommend sustained operation near these survivability limits.
- Operating at nominal conditions with $T_J \leq +150^\circ\text{C}$ will ensure $MTTF > 1 \times 10^6$ hours.

Handling Procedures

Please observe the following precautions to avoid damage:

Static Sensitivity

These electronic devices are sensitive to electrostatic discharge (ESD) and can be damaged by static electricity. Proper ESD control techniques should be used when handling these HBM Class 1A devices.

Truth Table & Bias Conditions

RF Common Path	Bias 1	Bias 2	Bias 3
RF1 Low Loss RF2 Isolation RF3 Isolation	$V_R = -10 V^4$	$I_F = +10 mA$	$I_F = +10 mA$
RF1 Isolation RF2 Low Loss RF3 Isolation	$I_F = +10 mA$	$V_R = -10 V^4$	$I_F = +10 mA$
RF1 Isolation RF2 Isolation RF3 Low Loss	$I_F = +10 mA$	$I_F = +10 mA$	$V_R = -10 V^4$

4. Reverse bias voltage should be determined based on working conditions. For example, -10 V @ 2 GHz, 29 dBm input power. For lower power applications, a less negative voltage can be used. R. Caverly and G. Hiller, "Establishing the Minimum Reverse Bias for a PIN Diode in a High Power Switch," IEEE Transactions on Microwave Theory and Techniques, Vol. 38, No. 12, December 1990. See Compression Power and Junction Temperature Performance curves for guidance.

RF Common Bias Configuration:

Option #1: Biased using internal resistance

- J9 to ground
- J8 un-connected
- Set V_R to -2 V⁵
- R1 value is 57 Ω

Option #2: Biased using external resistance

- J8 to external resistor (R_{BIAS}) to ground
- J9 un-connected
- $R_{BIAS} = (V_R - 1.4 V) / I_{DC}$

5. 29 dBm input power maximum.

Circuit Schematic

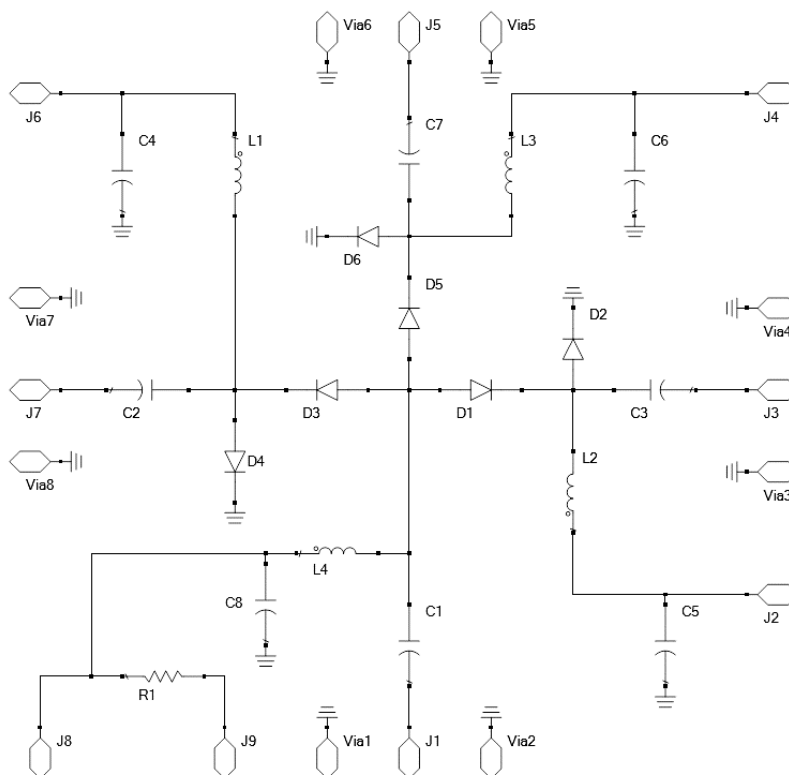

AlGaAs SP3T Switch with Integrated Bias Network

2 - 22 GHz



MASW-011130-DIE

Rev. V1

Typical RF Performance Curves, On-Wafer: $V_R = -2\text{ V}$, $I_F = +10\text{ mA}$, $P_{IN} = -10\text{ dBm}$

RF1 ON (RF1, RF3)

RF2 ON

Insertion Loss, (S21)

Insertion Loss, (S31)

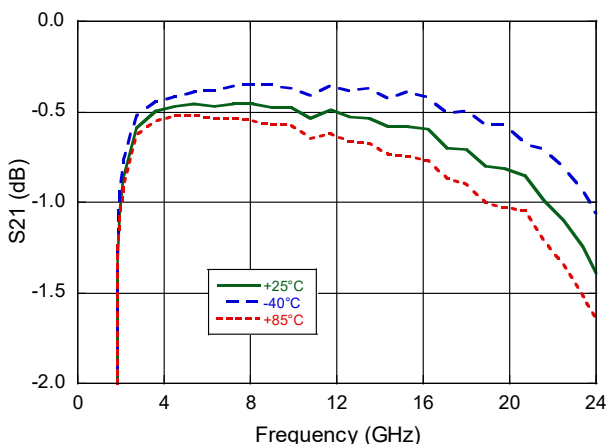
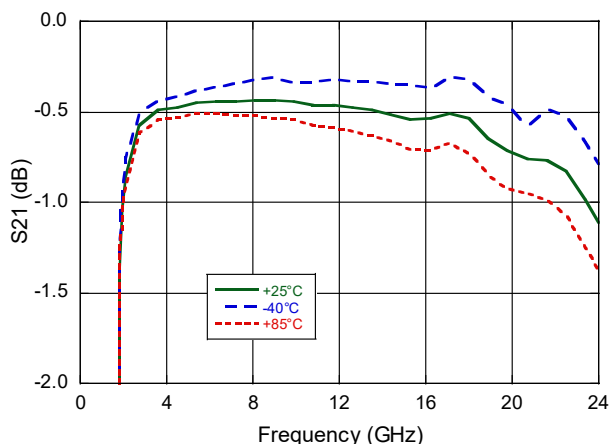

Isolation (RF Common to RF2, RF3), (S31, S41)

Isolation (RF Common to RF1, RF3), (S21, S41)

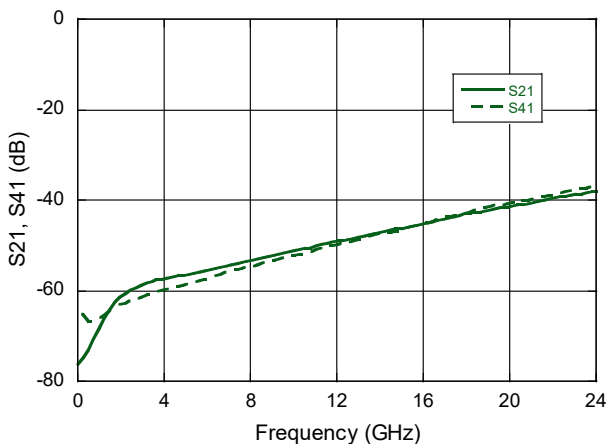
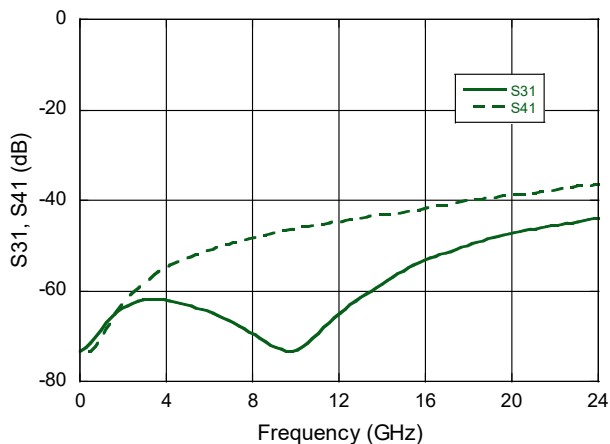

Return Loss, (S11, S33)

RFX Return Loss, (S11, S33)

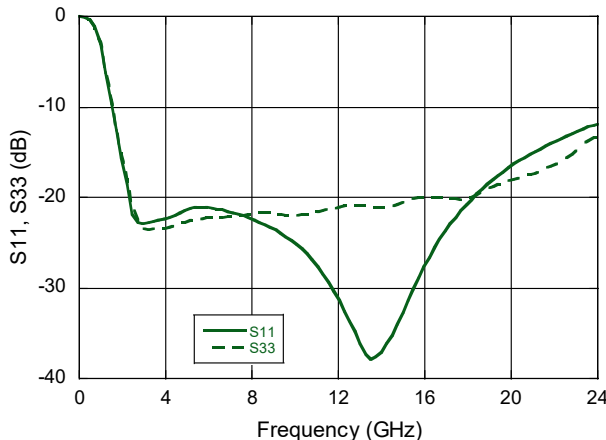
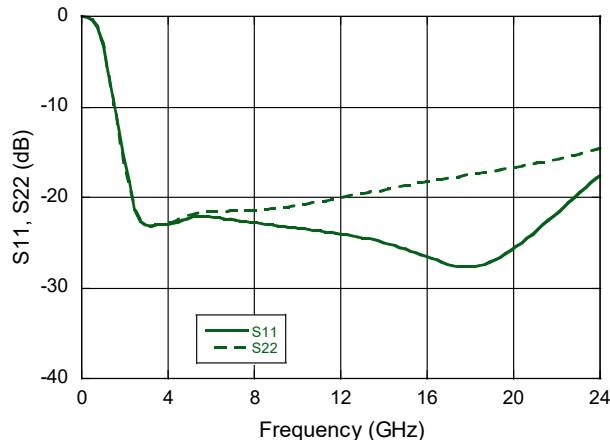

Typical RF Performance Curves, On-Board

IIP3 over Temperature, $P_{IN} = 5$ dBm per tone

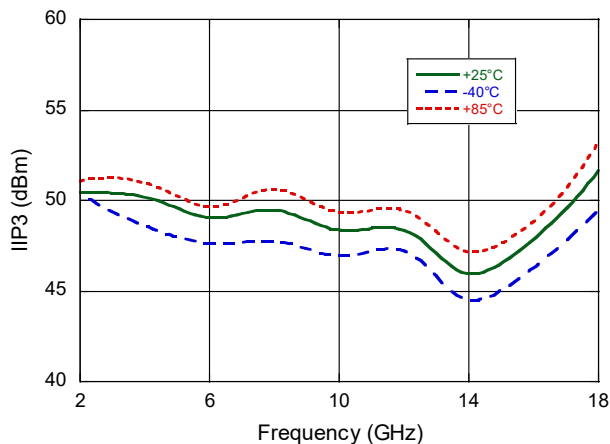

Junction Temperature over V_R @ 2 GHz, +85°C

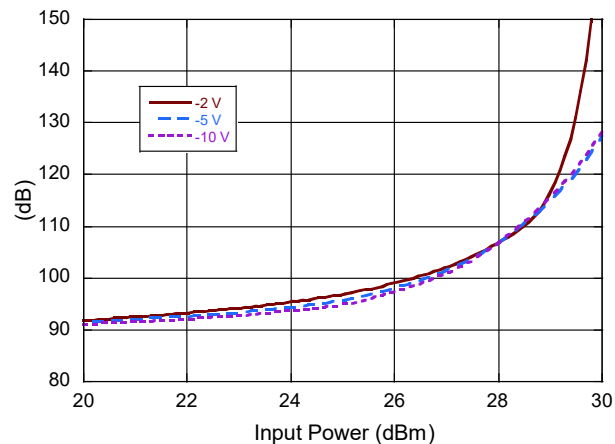

Compression Power, over Temperature @ 2 GHz, $V_R = -2$ V

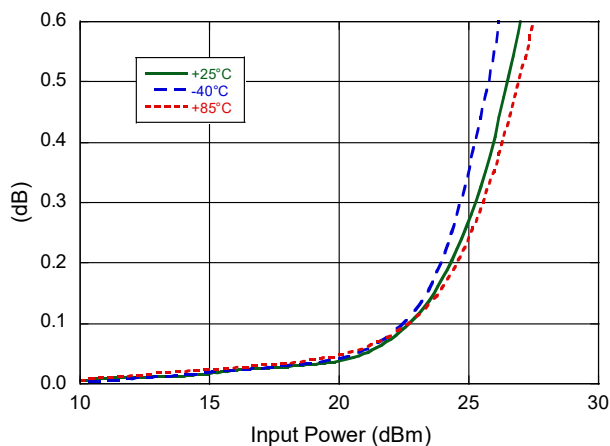

Compression Power, over Temperature @ 18 GHz, $V_R = -2$ V

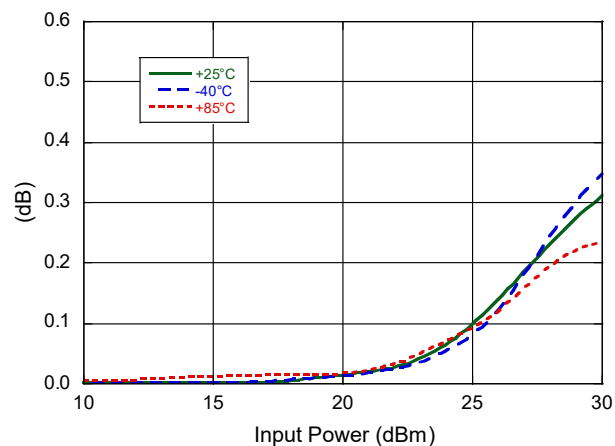

Compression Power, over V_R @ 2 GHz, +25°C

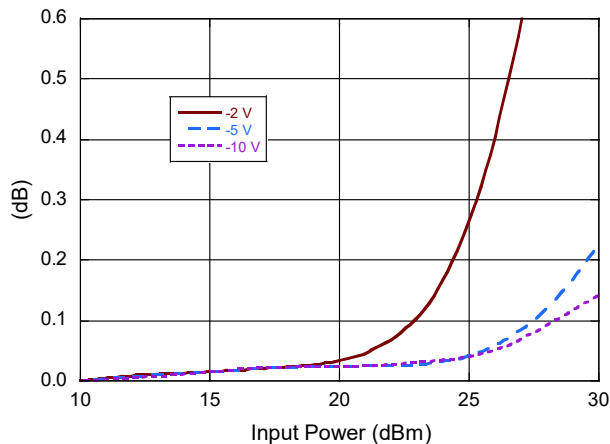

Compression Power, over V_R @ 18 GHz, +25°C

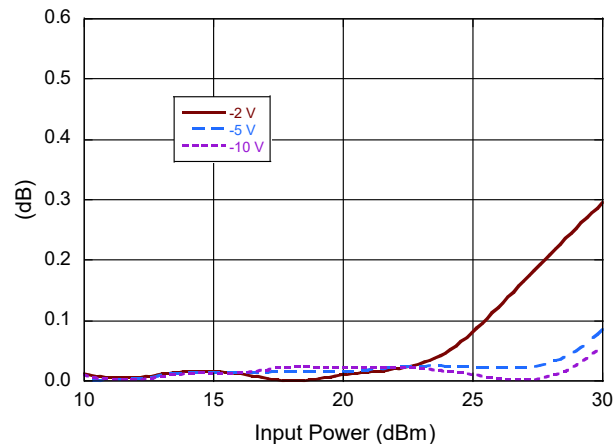

Solder Die Attach

All die attach and bonding methods should be compatible with gold metal. Solder which does not scavenge gold, such as 80 Au/20 Sn or Indalloy #2, is recommended. Do not expose die to a temperature greater than 300°C for more than 10 seconds.

Electrically Conductive Epoxy

Die Attach

Assembly can be preheated to approximately 125°C. Use a controlled thickness of approximately 1 mils for best electrical conductivity and lower thermal resistance. A thin epoxy fillet should be visible around the perimeter of the chip after placement. Cure epoxy per manufacturer's schedule. For extended cure times, temperatures should be kept below 150°C.

Wire / Ribbon Bonding

Wedge thermo compression bonding may be used to attach ribbons to the RF bonding pads. Gold ribbons should be at least 1/4 mil by 2 mil for lowest inductance. The same gold ribbon or 1 mil dia. gold wire is recommended for all DC pads.

Die Outline Drawing^{6,7,8,9,10}

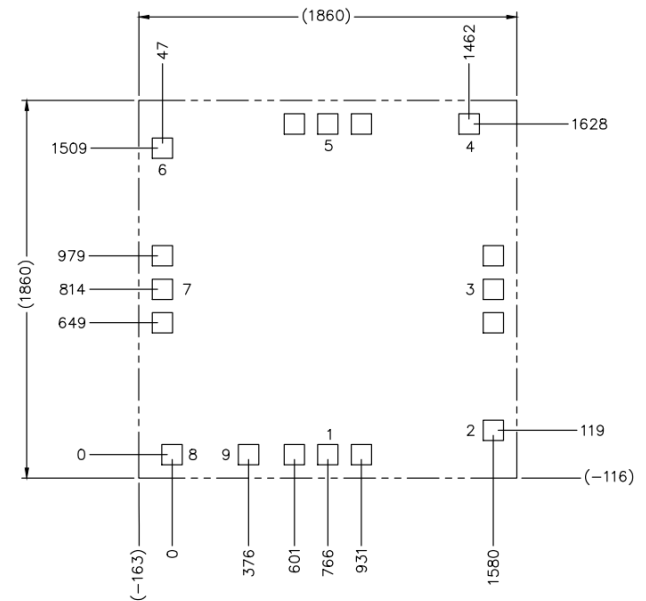

6. Bond pad dimensions 1 - 7, 100 μm x 100 μm .
7. Unless otherwise specified, all dimensions shown are μm with a tolerance of ±5 μm.
8. Die thickness is 100 μm, ±10 μm.
9. Bond pad / backside metallization: Gold
10. Die size reflects final saw dimensions.