

## SPDT High Isolation CATV Switch 5 – 1000 MHz

Rev V1

### Features

- 75 Ohm Impedance
- Input Terminated
- Positive Voltage Control
- High Isolation: 65 dB at 870 MHz
- 0.5 micron GaAs PHEMT Process
- Lead-Free 4 mm 20-Lead PQFN Package
- 100% Matte Tin Plating over Copper
- Halogen-Free “Green” Mold Compound
- RoHS\* Compliant and 260°C Reflow Compatible

### Description

M/A-COM's MASWSS0103 is a GaAs PHEMT MMIC single pole double throw (SPDT) switch in a lead-free 4 mm 20-lead PQFN package. The MASWSS0103 is ideally suited for applications where low control voltage, high isolation, small size and low cost are required.

Typical applications are to replace mechanical relays in CATV systems. This part can be used in all 75  $\Omega$  systems operating up to 1 GHz.

The MASWSS0103 is fabricated using a 0.5 micron gate length GaAs PHEMT process. The process features full passivation for performance and reliability.

### Ordering Information

Part Number	Package
MASWSS0103TR-3000	13 inch, 3000 piece reel
MASWSS0103SMB	Sample Test Board (Includes 5 Samples)

1: Reference Application Note M513 for reel size information.

### Functional Schematic

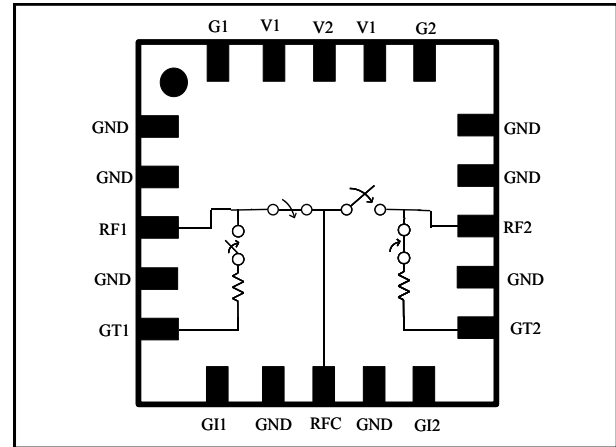

### Pin Configuration <sup>1</sup>

Pin No.	Pin Name	Description
1	GND	Ground
2	GND	Ground
3	RF1	RF Port 1
4	GND	Ground
5	GT1	RF Ground
6	GI1	RF Ground
7	GND	Ground
8	RFC	RF Common Port
9	GND	Ground
10	GI2	RF Ground
11	GT2	RF Ground
12	GND	Ground
13	RF2	RF Port 2
14	GND	Ground
15	GND	Ground
16	G2	RF Ground
17	V1	Control 1
18	V2	Control 2
19	V1	Control 1
20	G1	RF Ground

1. The exposed pad centered on the package bottom must be connected to RF and DC ground.

\* Restrictions on Hazardous Substances, European Union Directive 2002/95/EC.

## SPDT High Isolation CATV Switch 5 – 1000 MHz

Rev V1

**Electrical Specifications:**  $T_A = 25^\circ\text{C}$ ,  $Z_0 = 75 \Omega^2$ ,  $V_C = 0 \text{ V} / 2.9 \text{ V}$ ,  $P_{IN} = 10 \text{ dBm}$

Parameter	Test Conditions	Units	Min.	Typ.	Max.
Insertion Loss	5 - 50 MHz	dB	—	0.75	—
	50 - 1000 MHz	dB	—	1.0	1.2
Isolation	5 - 50 MHz	dB	—	100	—
	50 - 1000 MHz	dB	60	63	—
Return Loss (On)	5 - 50 MHz	dB	—	28	—
	50 - 1000 MHz	dB	—	16	—
Return Loss (Off)	5 - 50 MHz	dB	—	26	—
	50 - 1000 MHz	dB	—	16	—
IP3	Two Tone, +15 dBm/tone, 6 MHz spacing, > 50 MHz $V_C = 0 \text{ V} / 2.9 \text{ V}$ $V_C = 0 \text{ V} / 5.0 \text{ V}$	dBm	—	47	—
		dBm	—	52	—
Trise, Tfall	10% to 90% RF, 90% to 10% RF	nS	—	8	—
Ton, Toff	50% control to 90% RF, 50% control to 10% RF	nS	—	18	—
Transients	In Band	mV	—	70	—
Control Current	$ V_C  = 2.9 \text{ V}$	$\mu\text{A}$	—	5	10

2. External 0.01  $\mu\text{F}$  DC blocking capacitors are required on all RF In/Out and RF ground ports. See Application Schematic.

### Absolute Maximum Ratings<sup>3,4</sup>

Parameter	Absolute Maximum
Input Power (5 - 1000 MHz, 2.9 V Control)	+32 dBm
Operating Voltage	+8.5 volts
Operating Temperature	-40°C to +85°C
Storage Temperature	-65°C to +150°C

- Exceeding any one or combination of these limits may cause permanent damage.
- M/A-COM does not recommend sustained operation near these survivability limits.

### Truth Table<sup>5</sup>

V1	V2	RFC - RF1	RFC - RF2
1	0	On	Off
0	1	Off	On

5. 1 = +2.9 to +5 V, 0 = 0  $\pm$  0.2 V.

### Application Schematic

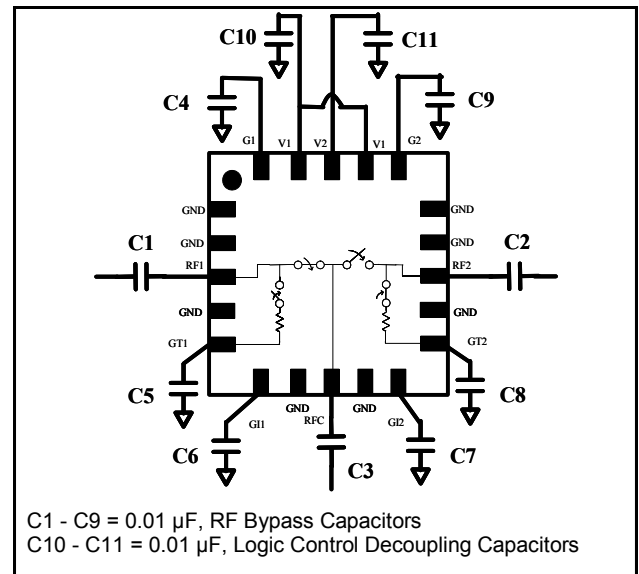

## SPDT High Isolation CATV Switch 5 – 1000 MHz

Rev V1

### Typical Performance Curves

#### Insertion Loss

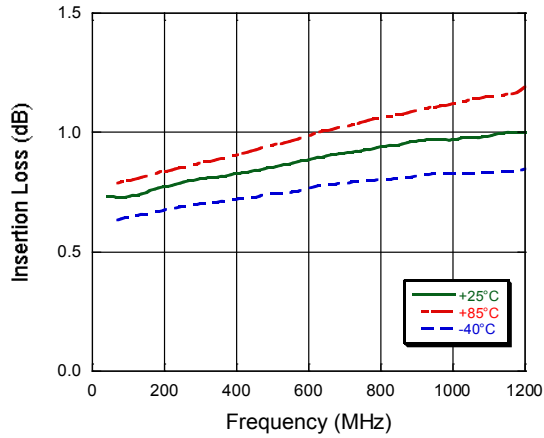

#### RF1 Isolation

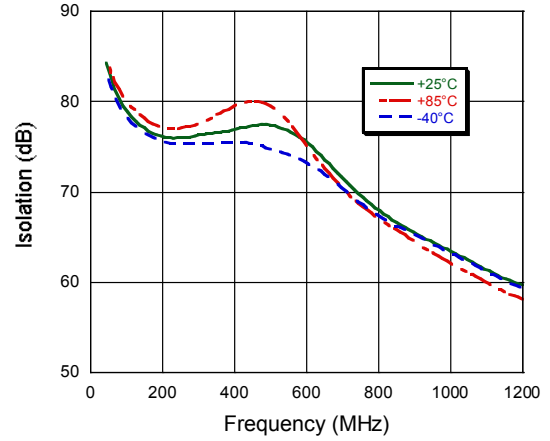

#### RF2 Isolation

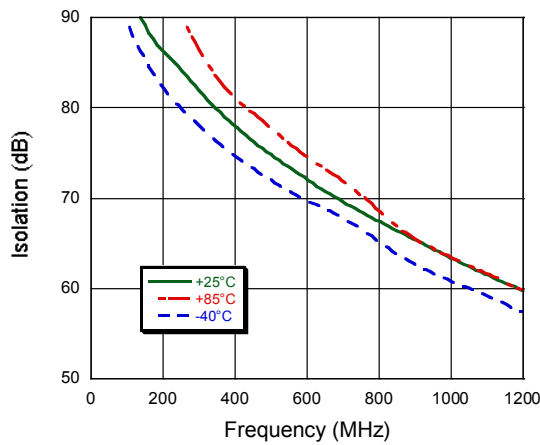

#### On Return Loss

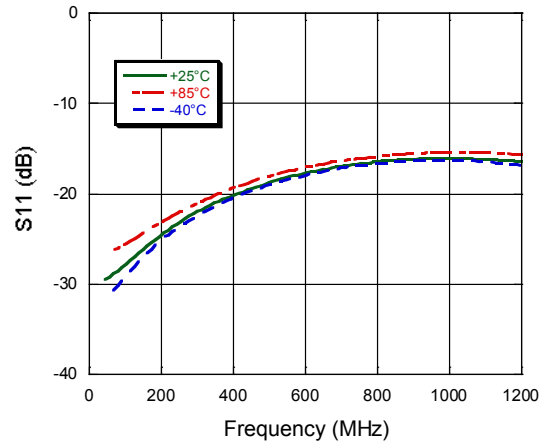

#### Off Return Loss

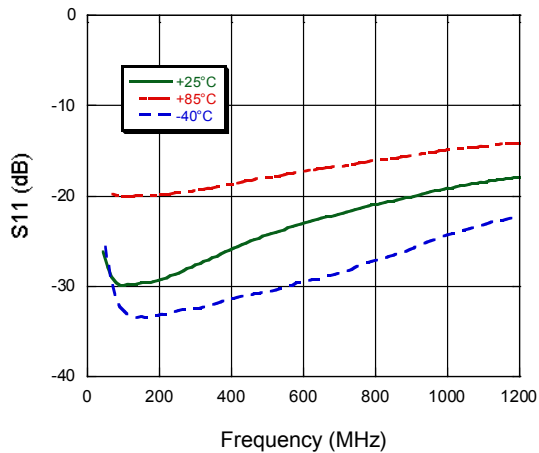

## SPDT High Isolation CATV Switch 5 – 1000 MHz

Rev V1

### Lead-Free 4 mm 20-Lead PQFN†

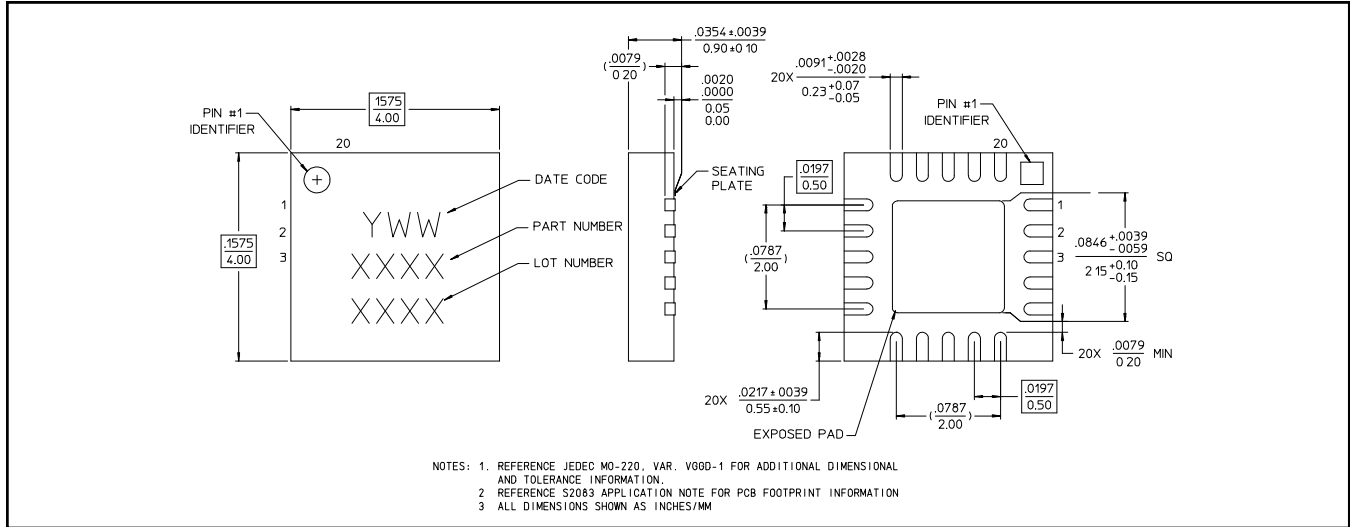

† Reference Application Note M538 for lead-free solder reflow recommendations.

## Handling Procedures

Please observe the following precautions to avoid damage:

## Static Sensitivity

Gallium Arsenide Integrated Circuits are sensitive to electrostatic discharge (ESD) and can be damaged by static electricity. Proper ESD control techniques should be used when handling these devices.