

## Features

- Low Insertion Loss: <0.5 dB @ 900 MHz
- Low Power Consumption: <1.0  $\mu$ A @ 3 VDC
- Very High Intercept Point: 52 dBm IP3
- Both Positive and Negative 3 to 8 V Control
- Lead-Free SOT-26 Package
- Halogen-Free "Green" Mold Compound
- 260°C Reflow Compatible
- RoHS\* Compliant Version of SW-395

## Description

The MASWSS0179 is a GaAs single pole, double throw switch in a lead-free SOT-26 surface mount plastic package and is ideally suited for applications where very low power consumption, low intermodulation products, very small size and low cost are required.

Typical application is an internal / external antenna select switch for portable telephones and data radios. In addition, because of its low loss, good isolation and inherent speed, this device can be used as a conventional T/R switch or as an antenna diversity switch. The MASWSS0179 can be used in power applications up to 0.5 watts in systems such as cellular, PCS, GSM and other analog / digital wireless communications systems.

This switch is fabricated using a mature 0.5-micron gate length GaAs pHEMT process. The process features full chip passivation for increased performance and reliability.

## Ordering Information <sup>1</sup>

Part Number	Package
MASWSS0179	Bulk Packaging
MASWSS0179TR-3000	3000 piece reel

1. Reference Application Note M513 for reel size information.

## Functional Schematic<sup>2</sup>

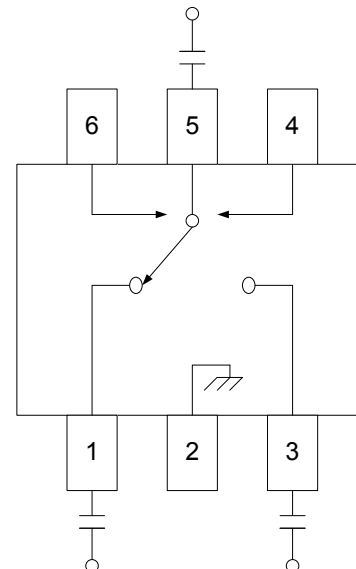

2. DC blocking capacitors are not required if negative control voltage is used.

## Pin Configuration

Pin No.	Function
1	RF1
2	Ground
3	RF2
4	Control B
5	RF Common
6	Control A

\* Restrictions on Hazardous Substances, European Union Directive 2011/65/EU.

## 3 V GaAs SPDT Switch DC - 2 GHz

Rev. V4

**Electrical Specifications:  $T_A = +25^\circ\text{C}$ ,  $V_C = 0\text{ V} / -3\text{ V}$ ,  $Z_0 = 50\ \Omega$**

Parameter	Test Conditions	Units	Min.	Typ.	Max.
Insertion Loss	DC - 1.0 GHz 1.0 - 2.0 GHz	dB	—	0.5 0.6	0.7 0.8
Isolation	DC - 1.0 GHz 1.0 - 2.0 GHz	dB	25 19	28 22	—
VSWR	DC - 2.0 GHz	Ratio	—	1.3:1	—
1 dB Compression	0.5 GHz, Input Power (3 V Control) 0.5 GHz, Input Power (5 V Control) 0.05 GHz, Input Power (3 V Control) 0.05 GHz, Input Power (5 V Control)	dBm	—	26 30 16 16	—
$T_{\text{RISE}}$ , $T_{\text{FALL}}$	10% to 90% RF, 90% to 10% RF	ns	—	3	—
$T_{\text{ON}}$ , $T_{\text{OFF}}$	50% Control to 90% RF, 50% Control to 10% RF	ns	—	5	—
Transients	In-Band	mV	—	15	—
Input $IP_2$	2-Tone, 5 MHz spacing, 3 V Control, 10 dBm each 0.05 GHz 0.5 GHz	dBm	—	69 80	—
Input $IP_3$	2-Tone, 5 MHz spacing, 3 V Control, 10 dBm each 0.05 GHz 0.5 GHz	dBm	—	48 52	—
Control Current	$ V_C  = 3\text{ V}$	$\mu\text{A}$	—	1	10

3. For positive voltage control, external DC blocking capacitors are required on all RF ports.

### Absolute Maximum Ratings<sup>4,5</sup>

Parameter	Absolute Maximum
Input Power	33 dBm
Operating Voltage	8.5 Volts
Storage Temperature	$-65^\circ\text{C}$ to $+150^\circ\text{C}$
Operating Temperature	$-40^\circ\text{C}$ to $+85^\circ\text{C}$

- Exceeding any one or combination of these limits may cause permanent damage to this device.
- MACOM does not recommend sustained operation near these survivability limits.

### Truth Table<sup>6,7,8</sup>

Control A	Control B	RFC to RF1	RFC to RF2
0	1	Off	On
1	0	On	Off

- For positive voltage control, external DC blocking capacitors are required on all RF ports.
- $0 = -8\text{ V}$  to  $0\text{ V}$ ,  $1 = 0\text{ V}$  to  $+8\text{ V}$ .
- Differential voltage,  $V$  (state 1) -  $V$  (state 0), must be  $+2.8\text{ V}$  minimum and must not exceed  $+8\text{ V}$ .

### Handling Procedures

Please observe the following precautions to avoid damage:

### Static Sensitivity

Gallium Arsenide Integrated Circuits are sensitive to electrostatic discharge (ESD) and can be damaged by static electricity. Proper ESD control techniques should be used when handling these devices.

## Typical Performance Curves

**Insertion Loss**

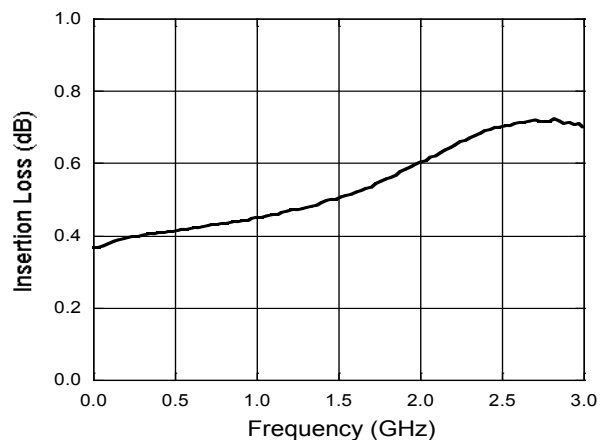

**Isolation**

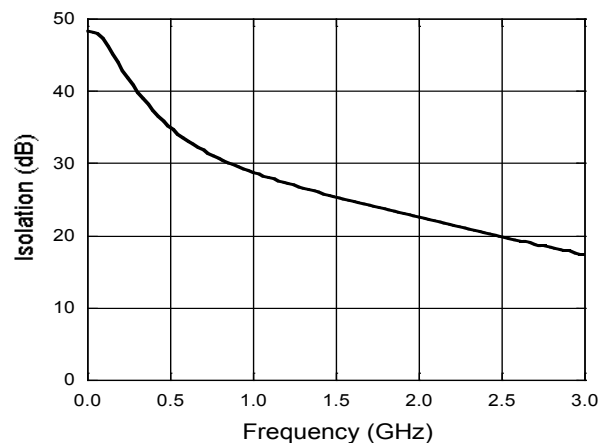

**VSWR**

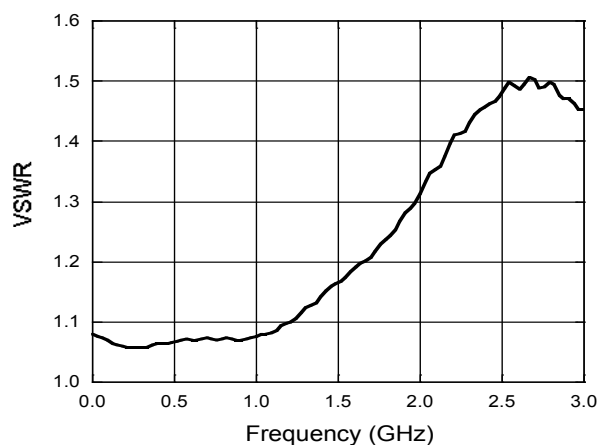

**Lead-Free SOT-26<sup>†</sup>**

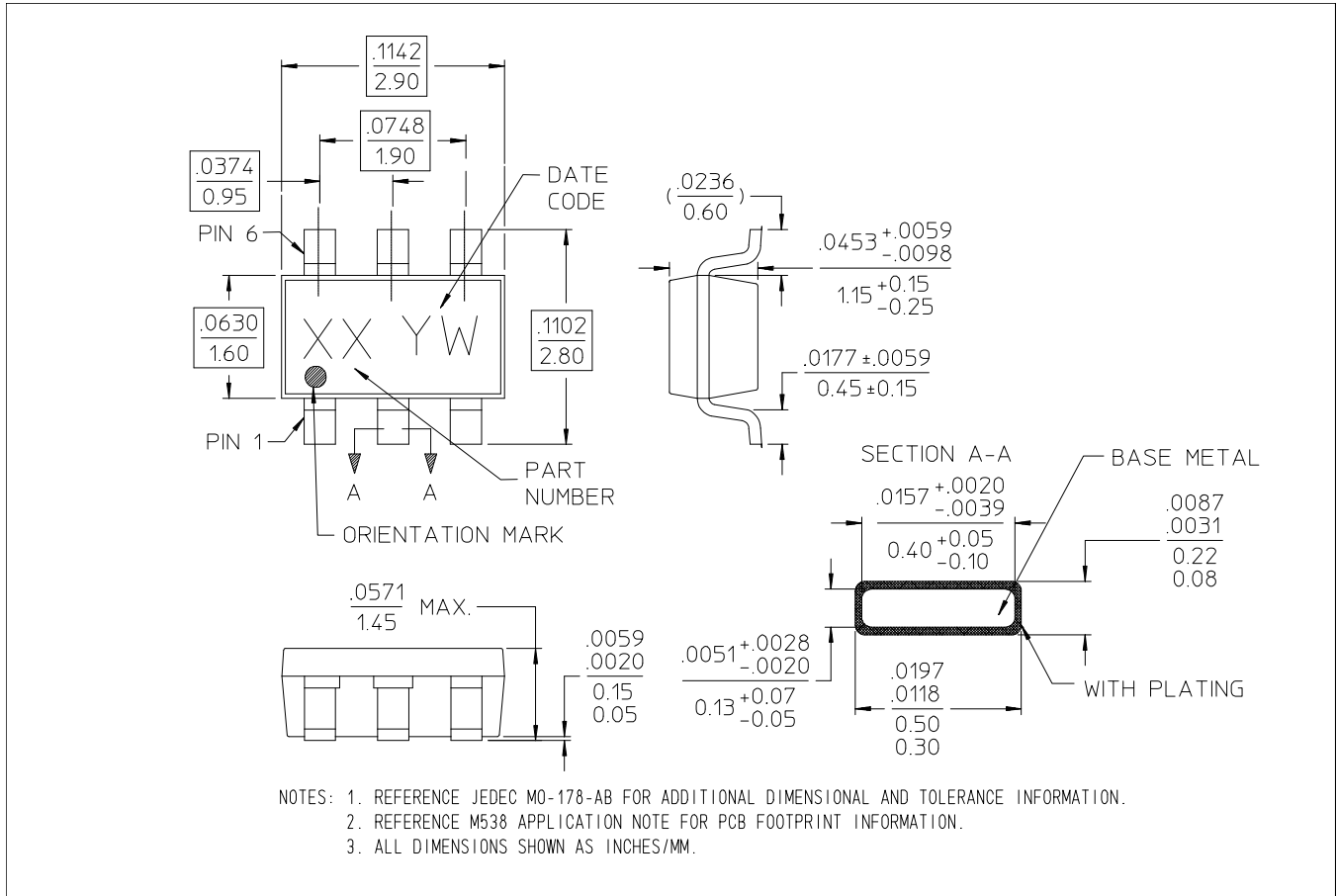

<sup>†</sup> Reference Application Note M538 for lead-free solder reflow recommendations.  
Meets JEDEC moisture sensitivity level 1 requirements.  
Plating is 100% matte tin over copper.