

GaAs Broadband SPDT Switch DC - 6.0 GHz

Rev. V1

Features

- 802.11a + b/g Dual Band Applications
- Broadband Performance: DC - 6.0 GHz
- Low Insertion Loss: 0.75 dB @ 5.8 GHz
- High Isolation: 22 dB @ 5.8 GHz
- Fast Switching Speed: 0.5 μ m GaAs PHEMT
- Lead-Free 3 mm 12-Lead PQFN Package
- 100% Matte Tin Plating over Copper
- Halogen-Free "Green" Mold Compound
- 260°C Reflow Compatible
- RoHS* Compliant Version of MASWSS0070

Description

M/A-COM's MASWSS0202 is a broadband GaAs PHEMT MMIC SPDT switch in a lead-free 3 mm 12-lead PQFN package. The MASWSS0202 is ideally suited for applications where very small size and low cost are required.

Typical applications are for WLAN IEEE 802.11a and 802.11b/g PC cards and access points. Other applications include cordless phones and base stations. Designed for high power, this SPDT switch maintains high linearity up to 6.0 GHz.

The MASWSS0202 is fabricated using a 0.5 micron gate length GaAs PHEMT process. The process features full passivation for performance and reliability.

Ordering Information ¹

Part Number	Package
MASWSS0202TR-3000	3000 piece reel
MASWSS0202SMB	Sample Test Board (Includes 5 Samples)

1. Reference Application Note M513 for reel size information.

Functional Schematic

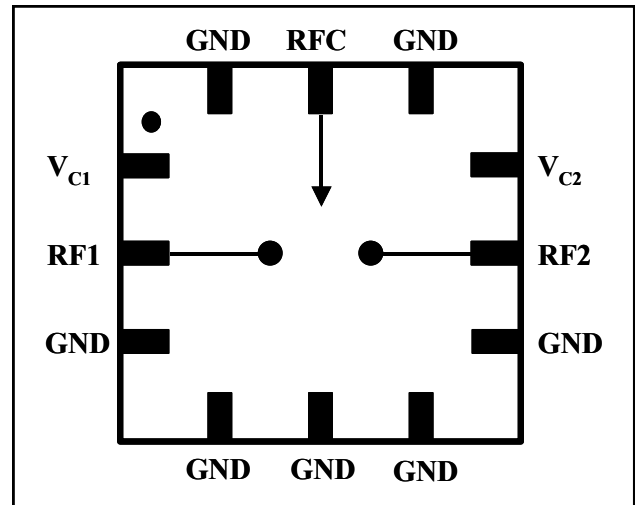

Pin Configuration ²

Pin No.	Pin Name	Description
1	V _{c1}	Control 1
2	RF1	RF Port
3	GND	Ground
4	GND	Ground
5	GND	Ground
6	GND	Ground
7	GND	Ground
8	RF2	RF Port
9	V _{c2}	Control 2
10	GND	Ground
11	RFC	RF Port
12	GND	Ground
13	Paddle ²	RF and DC Ground

2. The exposed pad centered on the package bottom must be connected to RF and DC ground.

* Restrictions on Hazardous Substances, European Union Directive 2002/95/EC.

GaAs Broadband SPDT Switch DC - 6.0 GHz

Rev. V1

Electrical Specifications: $T_A = 25^\circ\text{C}$, $Z_0 = 50 \Omega$, $V_C = 0 \text{ V} / 3 \text{ V}, 8 \text{ pF Capacitor}^3$

Parameter	Test Conditions	Units	Min.	Typ.	Max.
Insertion Loss ⁴	2 - 3 GHz	dB	—	0.55	0.9
	3 - 4 GHz	dB	—	0.55	0.9
	4 - 5 GHz	dB	—	0.65	1.0
	5 - 6 GHz	dB	—	0.75	1.1
Isolation	2 - 6 GHz	dB	22	25	—
Return Loss	DC - 6 GHz	dB	—	20	—
IIP2	Two Tone, +5 dBm / Tone, 5 MHz Spacing	dBm	—	91	—
	$V_C = 0.0 \text{ V} / 3 \text{ V} @ 2.4 \text{ GHz}$	dBm	—	81	—
	$V_C = 0.0 \text{ V} / 3 \text{ V} @ 5.8 \text{ GHz}$	dBm	—	99	—
	$V_C = 0.0 \text{ V} / 5 \text{ V} @ 2.4 \text{ GHz}$	dBm	—	91	—
IIP3	Two Tone, +5 dBm / Tone, 5 MHz Spacing	dBm	—	52	—
	$V_C = 0.0 \text{ V} / 3 \text{ V} @ 2.4 \text{ GHz}$	dBm	—	50	—
	$V_C = 0.0 \text{ V} / 3 \text{ V} @ 5.8 \text{ GHz}$	dBm	—	53	—
	$V_C = 0.0 \text{ V} / 5 \text{ V} @ 2.4 \text{ GHz}$	dBm	—	51	—
Input P-1dB	$V_C = 0.0 \text{ V} / 3 \text{ V} @ 2.4 \text{ GHz}$	dBm	—	32	—
	$V_C = 0.0 \text{ V} / 3 \text{ V} @ 5.8 \text{ GHz}$	dBm	—	29	—
	$V_C = 0.0 \text{ V} / 5 \text{ V} @ 2.4 \text{ GHz}$	dBm	—	37	—
	$V_C = 0.0 \text{ V} / 5 \text{ V} @ 5.8 \text{ GHz}$	dBm	—	35	—
2nd Harmonic	2.4 GHz, $P_{IN} = +20 \text{ dBm}$	dBc	—	-88	—
	5.3 GHz, $P_{IN} = +20 \text{ dBm}$	dBc	—	-91	—
	5.8 GHz, $P_{IN} = +20 \text{ dBm}$	dBc	—	-77	—
3rd Harmonic	2.4 GHz, $P_{IN} = +20 \text{ dBm}$	dBc	—	-87	—
	5.3 GHz, $P_{IN} = +20 \text{ dBm}$	dBc	—	-81	—
	5.8 GHz, $P_{IN} = +20 \text{ dBm}$	dBc	—	-85	—
T-rise, T-fall	10% to 90% RF and 90% to 10% RF	nS	—	13	—
Ton, Toff	50% control to 90% RF, 50% control to 10% RF	nS	—	35	—
Transients	—	mV	—	14	—
Control Current	$ V_C = 3 \text{ V}$	μA	—	10	25

3. For positive voltage control, external DC blocking capacitors are required on all RF ports.

4. Insertion loss can be optimized by varying the DC blocking capacitor value.

Truth Table ⁵

Control V1	Control V2	RFC—RF1	RFC—RF2
1	0	On	Off
0	1	Off	On

5. 1 = +2.9 V to +5 V, 0 = 0 V \pm 0.2 V.

Absolute Maximum Ratings ^{6,7}

Parameter	Absolute Maximum
Input Power @ 3 V Control	+32 dBm
Input Power @ 5 V Control	+34 dBm
Operating Voltage	+8.5 volts
Operating Temperature	-40°C to +85°C
Storage Temperature	-65°C to +150°C

6. Exceeding any one or combination of these limits may cause permanent damage to this device.

7. M/A-COM does not recommend sustained operation near these survivability limits.

GaAs Broadband SPDT Switch DC - 6.0 GHz

Rev. V1

Lead-Free 3 mm 12-Lead PQFN†

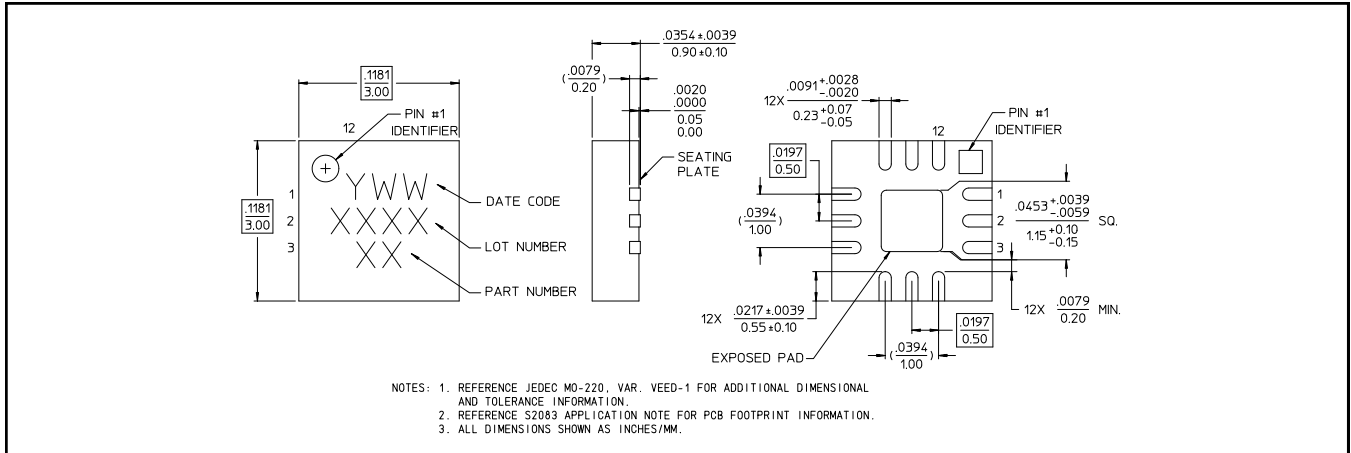

† Reference Application Note M538 for lead-free solder reflow recommendations.

Evaluation Board

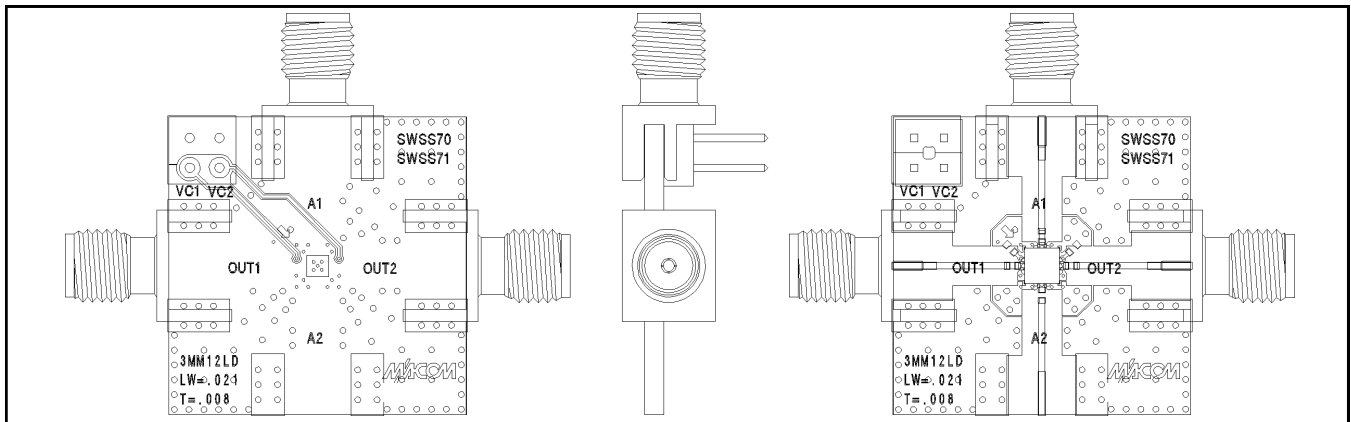

Application Schematic

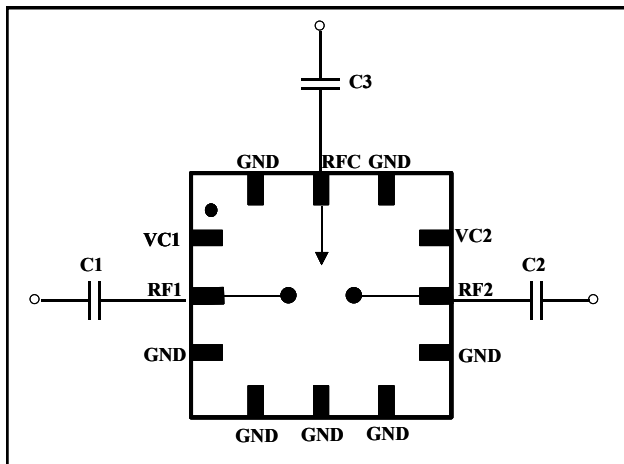

Application #1: Optimized for 802.11a (5-6 GHz)

Qty.	Description
3	Capacitor, 3.0 pF, 0402, SMT, 5% (C1-C3)

Application #2: Optimized for 802.11b/g (2.4 GHz)

Qty.	Description
3	Capacitor, 8.0 pF, 0402, SMT, 5% (C1-C3)

Typical Performance Curves with 0 / 3 V Control, 8 pF Capacitors

Insertion Loss

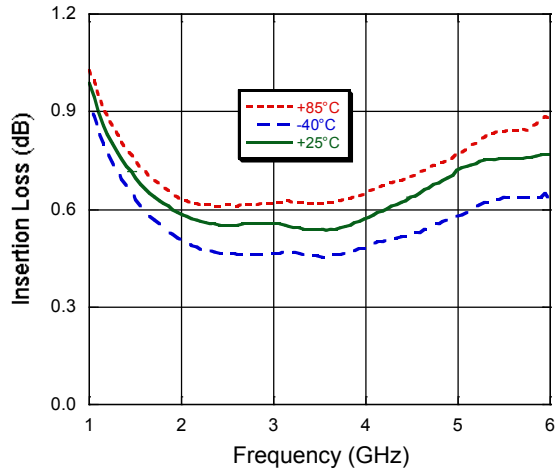

Isolation

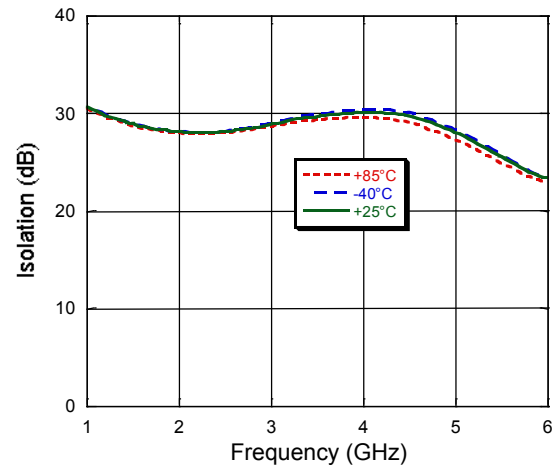

Return Loss

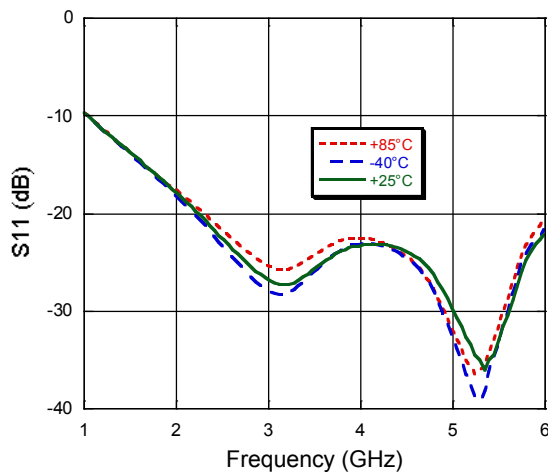

Qualification

Qualified to M/A-COM specification REL-201, Process Flow -2.

Handling Procedures

Please observe the following precautions to avoid damage:

Static Sensitivity

Gallium Arsenide Integrated Circuits are sensitive to electrostatic discharge (ESD) and can be damaged by static electricity. Proper ESD control techniques should be used when handling these devices.