

General Description

The MAX14746 evaluation kit (EV kit) is a fully assembled and tested circuit for evaluating the MAX14746/MAX14747 charger detectors with a linear battery charger and a smart power selector.

Refer to the MAX14746 IC data sheet for detailed information regarding the operation and features of the devices.

The EV kit comes standard with the MAX14746 installed, but can also be used to evaluate the MAX14747 by replacing the MAX14746 (U1) with the MAX14747. Request a free sample of the MAX14747 when ordering the EV kit.

Features

- RoHS Compliant
- Proven PCB Layout
- Full Assembled and Tested
- I²C Serial Interface

[Ordering Information](#) appears at end of data sheet.

Detailed Description of Hardware

Jumper Descriptions

[Table 1](#) details the functions of the configurable jumper headers on the EV kit board. The headers are standard 0.1in spacing, 0.025in posts.

Table 1. Jumper Functions and Default Settings

JUMPER	SETTINGS	DESCRIPTION
JU1 D1	Open	Indicator LED D1 off
	Closed*	Indicator LED D1 on
JU2 CTYP	Open	Disconnect $\overline{\text{CTYP}}$ output from indicator LED D2
	Closed*	Connect $\overline{\text{CTYP}}$ output to indicator LED D2
JU3 UOK2	Open	Disconnect UOK2 output to indicator LED D3
	Closed*	Connect UOK2 output to indicator LED D3
JU4 UOK1	Open	Disconnect UOK1 output and LED D4
	Closed*	Connect UOK1 output to indicator LED D4
JU5 IDEF	1-2	Connect IDEF to VIO
	2-3*	Connect IDEF to GND

Table 1. Jumper Functions and Default Settings) (continued)

JUMPER	SETTINGS	DESCRIPTION
JU6 FSUS	1-2	Connect FSUS to VIO
	2-3*	Connect FSUS to GND
JU7 SDA	Open	Disconnect SDA from R10 (Pullup)
	Closed*	Connect SDA to R10 (Pullup)
JU8 THM	1-2	Connect THM to R14
	2-3	Connect THM to R16
JU9 SCL	Open	Disconnect SCL from R11 (Pullup)
	Closed*	Connect SCL to R11 (Pullup)
JU10 INT	Open	Disconnect INT from R12 (Pullup)
	Closed*	Connect INT to R12 (Pullup)
JU11 VMC	Open	Disconnect VIO from VMC
	Closed*	Connect VIO to VMC
JU12 SYS	Open	Disconnect SYS from C10
	Closed*	Connect SYS to C10
JU13 BAT	Open	Disconnect BAT from Q2
	Closed*	Connect BAT to Q2
	1-2, 3-4	
JU14 SYS	Open	Disconnect SYS from Q2
	Closed*	Connect SYS to Q2
JU15 UOK2EXT	1-2*	Connect UOK2EXT to Q2
	3-4	Connect UOK2EXT to JU3 (UOK2)
JU16 LED	Open	Disconnect SYS from indicator D5 LED
	Closed*	Connect SYS to indicator D5 LED
JU17 EXT	Open	Disconnect R15 from JU15 (EXT)
	Closed*	Connect R15 to JU15 (EXT)

*Default Position

Digital Inputs and Outputs

The bias for the logic inputs and the open-drain indicators can be provided from the VMC pin of J4 connector or from the pins 6 and 12 of J5. Install jumper JU11 to use VMC for the VIO supply.

The UOK1, UOK2, INT, CTYP open-drain outputs use VIO supply for their respective pullup voltages. Jumpers JU1–JU4 connect the indicator LEDs D1–D4 to these open-drain flags. LED pin is another open-drain output, the status of which is reflected by indicator D5 when JU16 is installed.

UOK2/EXT pin is preconfigured by factory as either UOK2 or EXT. EXT is a push-pull output used to control the external pMOS load switch Q2. When charger is not present, EXT is high and Q2 connects SYS to BAT. Connect JU15 accordingly based on which function UOK2/EXT is preconfigured to.

IDEF and FSUS are digital inputs set by JU5 and JU6. IDEF determines if the current limit is fixed at 100mA or controlled by I²C settings (IBusLim, ILimSet, IBusDetSw bits); FSUS, if pulled high, forces the input current limit to 0A

USB Interface

The MAX14746 provides an integrated USB2.0 full-speed interface (12Mbps). This interface is accessed through the Micro-USB type-B connector, J1 and type-A connector J3. VBUS of J1 is also the power source for the U1.

I/O Interface Connector

The EV kit allows accessing the digital I/O of the MAX14746 individually through three different interface connectors, J2, J4, and J5. Please refer to [Table 2](#) thru [Table 4](#) for the connectors pin description.

Table 2. Aardvark Connector J2

PIN	MAX14746	DESCRIPTION
1	SCL	I ² C Serial Clock Input
2	GND	Ground
3	SDA	I ² C Serial Data Input/Output
4	N.C.	Not Connected
5	N.C.	Not Connected
6	N.C.	Not Connected
7	INT	Active-Low Interrupt Output
8	N.C.	Not Connected
9	N.C.	Not Connected
10	GND	Ground

Table 3. 40-Pin Connector J4

PIN	SIGNAL	DESCRIPTION
2	GND	Ground
4	VMC	3.3V Supply Input
10	GND	Ground
21	IDEF	Current-Limit Setting Input
22	FSUS	Force-Suspend Enable Input
28	$\overline{\text{INT}}$	Active-low Interrupt Output
29	GND	Ground
33	SDA	I ² C Serial Data Input/Output
34	SCL	I ² C Serial Clock Input
40	GND	Ground
All Other Pins	N.C.	Not Connected

Table 4. PMOD Connector J5

PIN	MAX14746	DESCRIPTION
1	FSUS	Force-Suspend Enable Input
2	N.C.	Not Connected
3	SCL	I ² C Serial Clock Input
4	SDA	I ² C Serial Data Input/Output
5	GND	Ground
6	VIO	3.3V Digital Input/Output Supply
7	IDEF	Current-Limit Setting Input
8	$\overline{\text{INT}}$	Active-Low Interrupt Output
9	N.C.	Not Connected
10	N.C.	Not Connected
11	GND	Ground
12	VIO	Digital Interface Supply

Ordering Information

PART	TYPE
MAX14746EVKIT#	EV Kit

#Denotes RoHS compliant.

MAX14746 EV Kit Bill of Materials

ITEM	REF_DES	DNI/ DNP	QTY	MFG PART #	MFTR	VALUE	DESCRIPTION
1	BAT, THM	-	2	5013	KEYSTONE	N/A	TEST POINT; PIN DIA=0.125IN; TOTAL LENGTH=0.445IN; BOARD HOLE=0.063IN; ORANGE; PHOSPHOR BRONZE WIRE SILVER PLATE FINISH;
2	BAT_MON, SYS_MON	-	2	5012	KEYSTONE	N/A	TEST POINT; PIN DIA=0.125IN; TOTAL LENGTH=0.445IN; BOARD HOLE=0.063IN; WHITE; PHOSPHOR BRONZE WIRE SILVER PLATE FINISH;
3	C1, C6-C8	-	4	C0603X5R160-105KNP; EMK107BJ105KA; C1608X5R1C105K; GRM188R61C105K	VENKEL LTD./TAIYO YUDEM/TDK/M URATA	1UF	CAPACITOR; SMT; 0603; CERAMIC; 1uF; 16V; 10%; X5R; -55degC to +85degC; 0 +/-15% degC MAX.USE 20-0001u-63 FOR NEW DESIGN
4	C2-C5	-	4	CL31B106KOHNNN	SAMSUNG ELECTRONIC S	10UF	CAPACITOR; SMT (1206); CERAMIC CHIP; 10UF; 16V; TOL=10%; TG=-55 DEGC TO +125 DEGC; TC=X7R
5	C9	-	1	GRM21BR71H105KA12; CL21B105KBFNNNE; C2012X7R1H105K085AC; UMK212B7105KG	MURATA; SAMSUNG ELECTRONIC S; TDK; TAIYO YUDEM	1UF	CAPACITOR; SMT (0805); CERAMIC CHIP; 1UF; 50V; TOL=10%; TG=-55 DEGC TO +125 DEGC; TC=X7R
6	C10	-	1	T494D476K016AT	KEMET	47UF	CAPACITOR; SMT (7343); TANTALUM CHIP; 47UF; 16V; TOL=10%; MODEL=T494 SERIES
7	C11	-	1	CL31B225KBHNNN	SAMSUNG ELECTRONIC S	2.2UF	CAPACITOR; SMT (1206); CERAMIC CHIP; 2.2UF; 50V; TOL=10%; TG=-55 DEGC TO +125 DEGC; TC=X7R
8	VB, CAP, SYS	-	3	5010	KEYSTONE	N/A	TESTPOINT WITH 1.80MM HOLE DIA, RED, MULTIPURPOSE;
9	D1-D4, D6	-	5	PG1101W	STANLEY ELECTRIC CO	PG1101W	DIODE; LED; 1101W SERIES; GREEN; SMT (1206); VF=2.1V; IF=0.03A
10	D5	-	1	SML-LX1206IW	LUMEX OPTOCOMPO NENTS INC	SML-LX1206IW	DIODE; LED; 635NM RED LED; MILKY WHITE DIFFUSED LENS; RED; SMT (1206); VF=2V; IF=0.1A
11	J1	-	1	ZX62-B-5PA	HIROSE ELECTRIC CO LTD.	ZX62-B-5PA	CONNECTOR; FEMALE; SMT; USB MICRO B-TYPE; BOTTOM MOUNT; RIGHT ANGLE; 5PINS; -30 DEGC TO +85 DEGC; WITH OPTION TO CONNECT SHIELD PINS
12	J2	-	1	5104338-1	TE CONNECTIVIT Y	5104338-1	CONNECTOR; MALE; THROUGH HOLE; AMP LATCH LOW PROFILE HEADER; STRAIGHT; 10PINS
13	J3	-	1	896-43-004-90-000000	MILL-MAX	896-43-004-90-000000	CONNECTOR; FEMALE; THROUGH HOLE; USB RECEPTACLE; 896 SERIES; RIGHT ANGLE; 4PINS
14	J4	-	1	SBH11-PBPC-D20-ST-BK	SULLINS ELECTRONIC S CORP.	SBH11-PBPC-D20-ST-BK	CONNECTOR; MALE; THROUGH HOLE; HEADER CONNECTOR; STRAIGHT; 40PINS
15	J5	-	1	TSW-106-08-S-D-RA	SAMTEC	TSW-106-08-S-D-RA	CONNECTOR; THROUGH HOLE; DOUBLE ROW; RIGHT ANGLE; 12PINS;
16	J6-J9	-	4	EVKIT_STANDOFF_4-40_1/2	?	EVKIT_STANDOFF_4-40_1/2	KIT; ASSY-STANDOFF1/2IN; 1PC. STANDOFF/FEM/HEX/4-40/(1/2IN)/ALUMINUM; 1PC. SCREW/PHL/PAN/4-40/(3/8IN)/18-8 STAINLESS STEEL

MAX14746 EV Kit Schematics

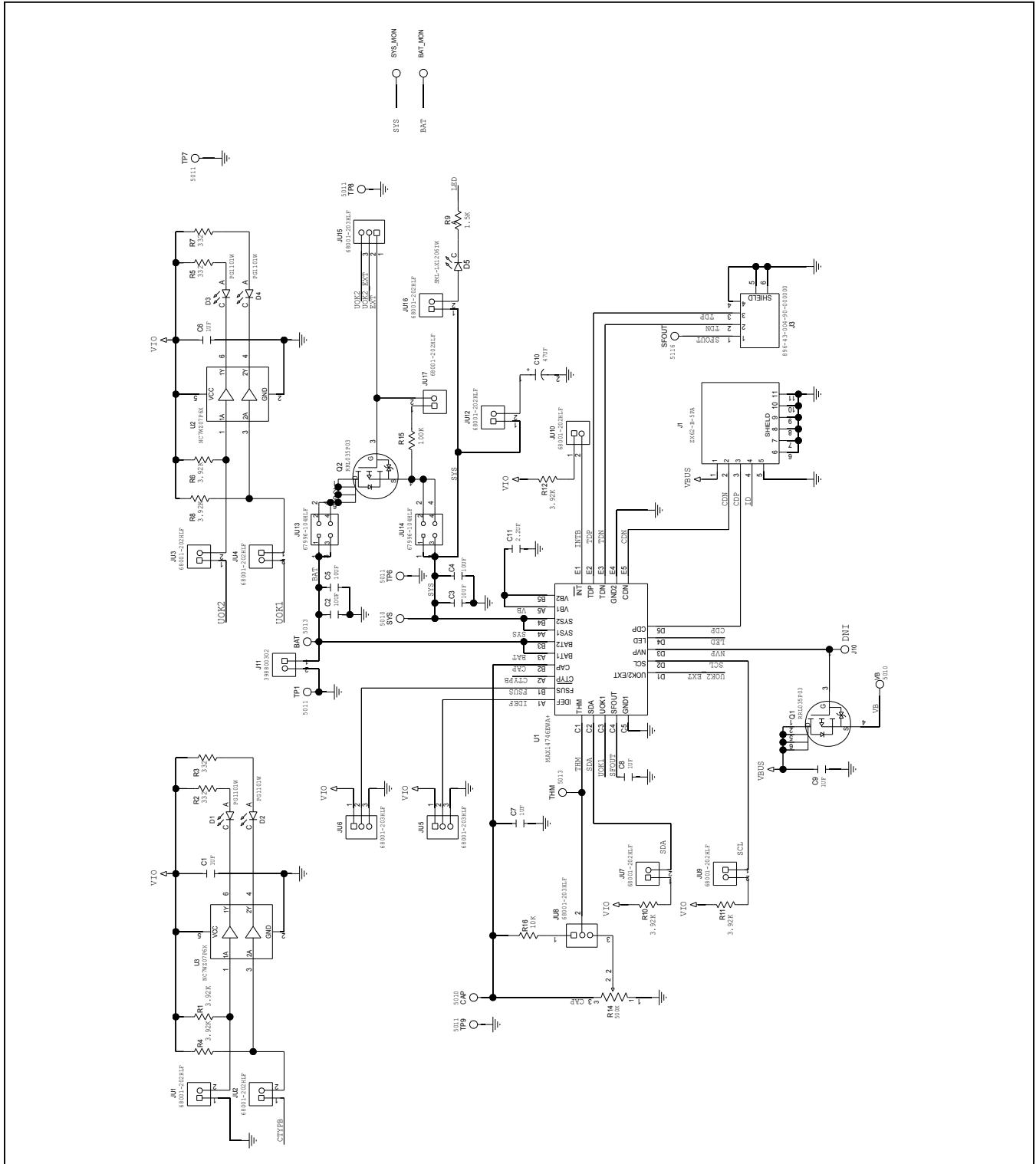

MAX14746 EV Kit Schematics (continued)

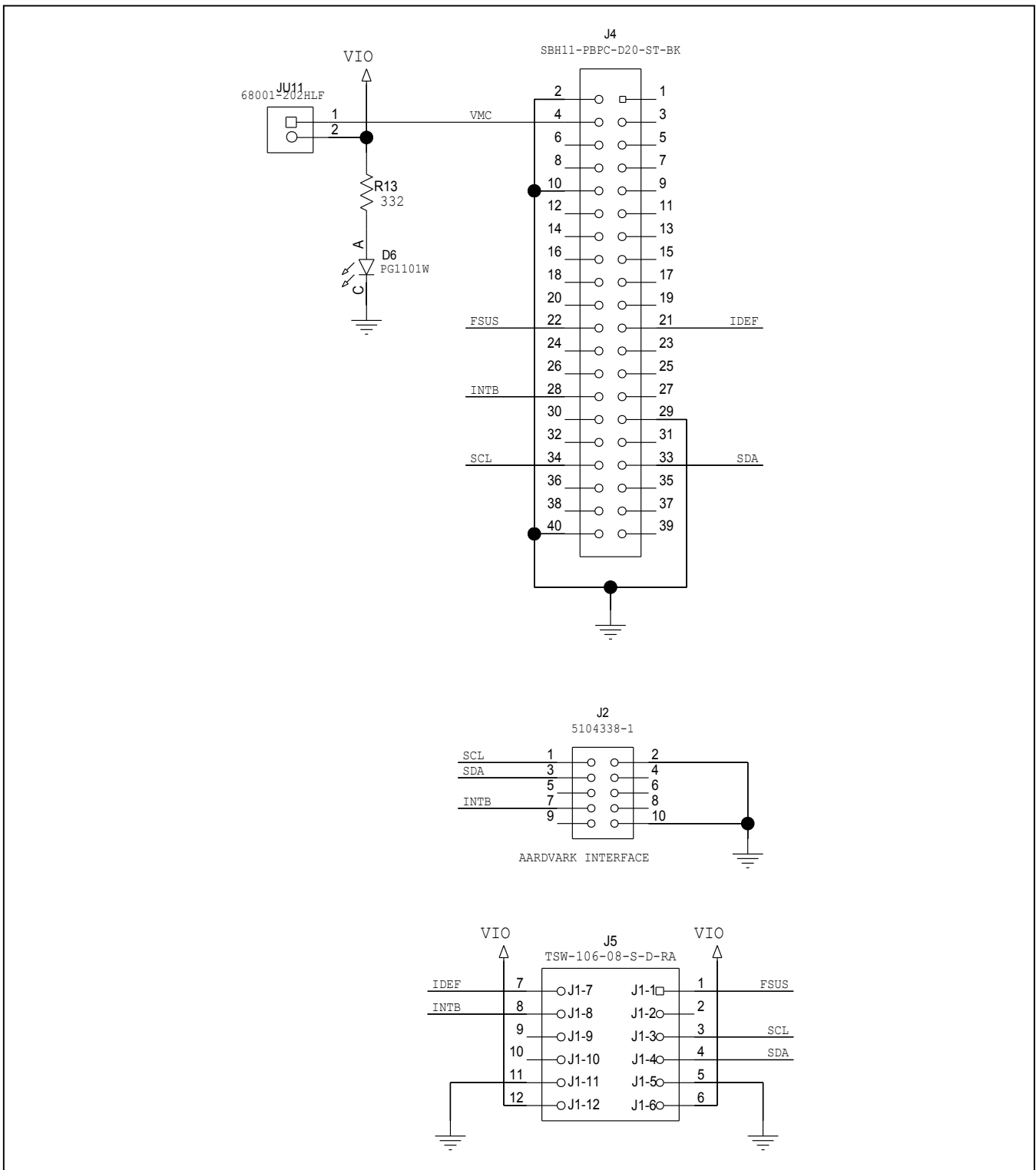

MAX14746 EV Kit PCB Layouts

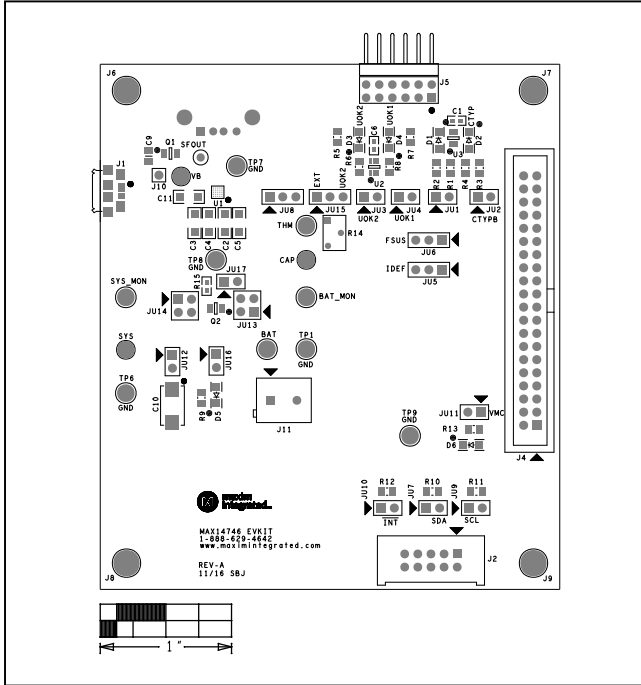

MAX14746 EV Kit—Top Silkscreen

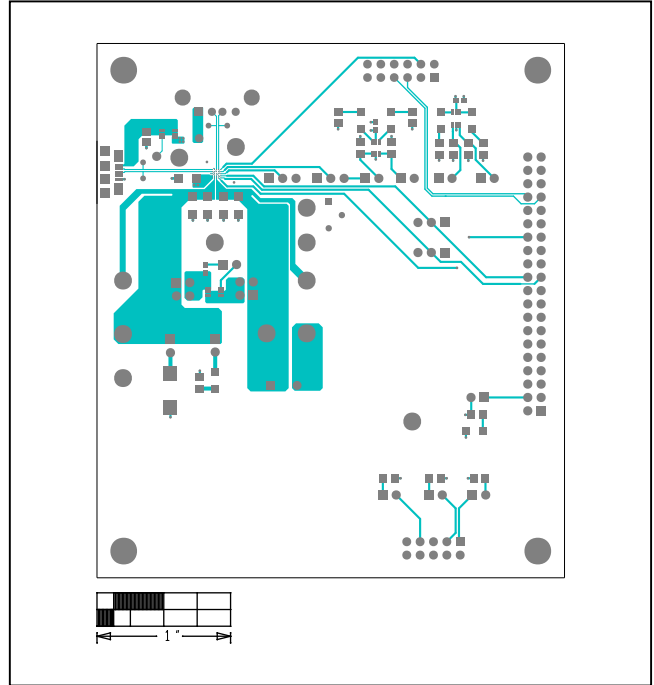

MAX14746 EV Kit—Top

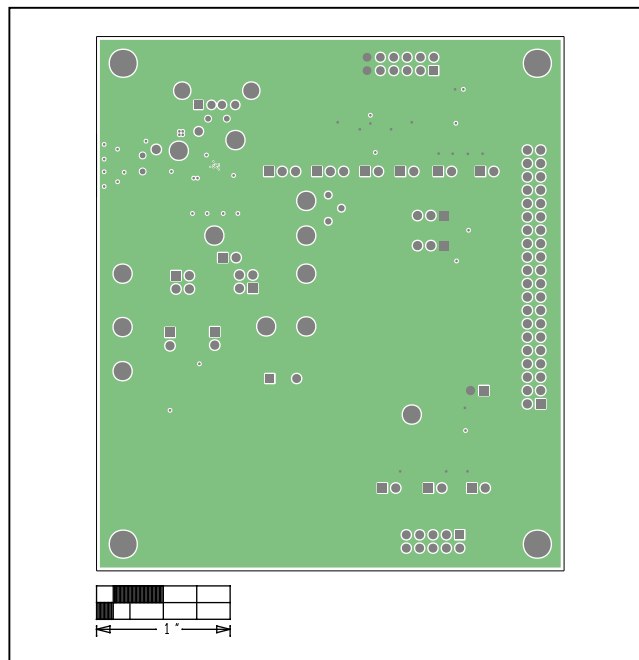

MAX14746 EV Kit—Internal 2

MAX14746 EV Kit PCB Layouts (continued)

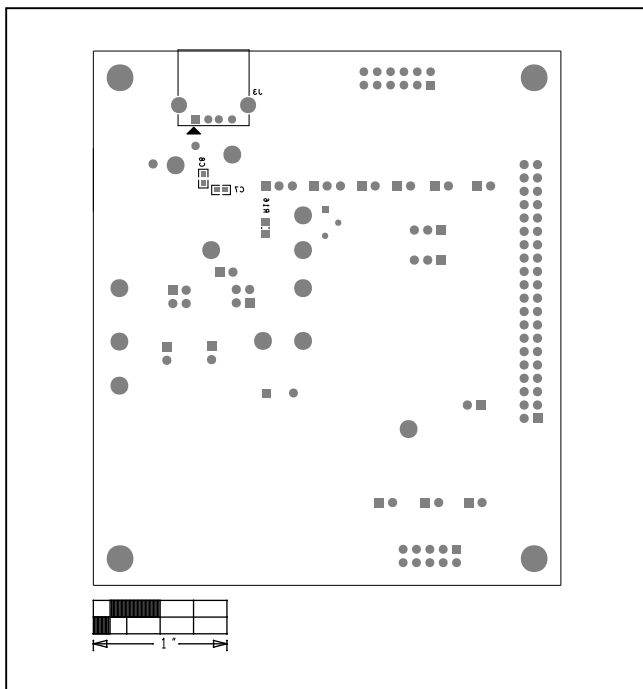

MAX14746 EV Kit—Bottom Silkscreen

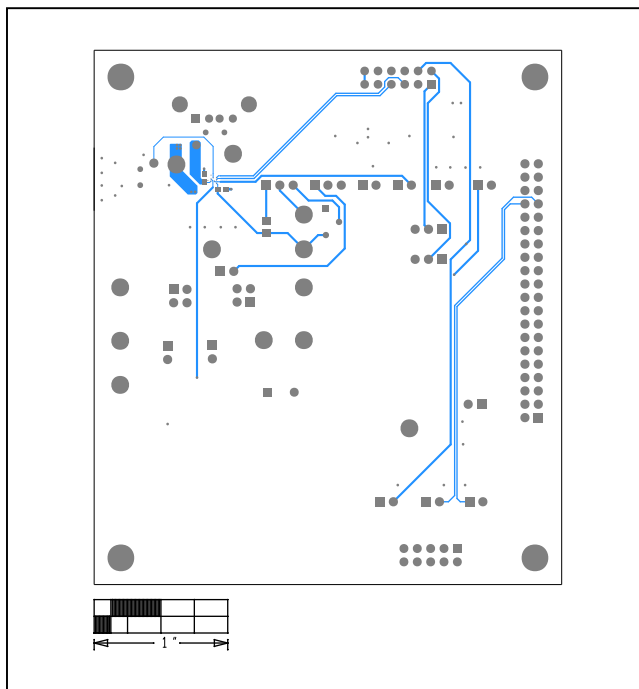

MAX14746 EV Kit—Bottom

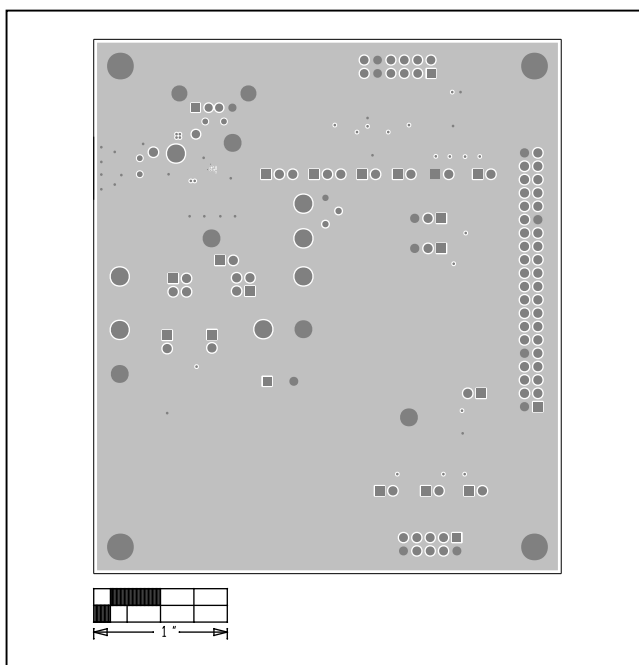

MAX14746 EV Kit—Internal 1