

## MAX14829 Evaluation Kit

Evaluates: MAX14829

### General Description

The MAX14829 evaluation kit (EV kit) is a fully assembled and tested circuit board that evaluates the MAX14829 IO-Link® device transceiver.

The MAX14829 EV kit can be operated stand-alone with pin-strapping or can be driven by a microcontroller using the Arduino-compatible interface.

### Features

- IO-Link-Compliant Device Transceiver
- IO Interface Terminals
- Proven PCB Layout
- Fully Assembled and Tested
- Pads for an Arduino Compatible Shield

### Quick Start

#### Recommended Equipment

- MAX14829 EV kit
- 24V, 500mA DC power supply
- Multimeter
- Function generator
- Oscilloscope

*IO-Link is a registered trademark of ifm electronic GmbH.*

### Procedure

The EV kit is fully assembled and tested. Follow the steps below to verify board operation before exercising the full features of the device:

- 1) Verify that all the jumpers are in their default positions, as shown in [Table 1](#).
- 2) Ensure that SW1 is set to position 1 (to the far left).
- 3) Connect the 24V DC power supply on the V<sub>24</sub> (TP1 or TP3) and GND (TP4 or TP19) connectors of the EV kit board.
- 4) Connect the oscilloscope to the C/Q test point (TP8).
- 5) Turn on the power supply.
- 6) Connect the multimeter to pin 1 on the J4 jumper. Verify that the voltage on the multimeter is 5V.
- 7) Connect the multimeter to pin 3 on the J4 jumper. Verify that the voltage on the multimeter is 3.3V.
- 8) Set the function generator to generate a 0 to 3.3V square wave at 100kHz.
- 9) Connect the oscilloscope to the TX (TP19) and C/Q (TP8) test points.
- 10) Connect the function generator to the TX test point (TP19).
- 11) Enable the function generator.
- 12) Verify that the C/Q output switches with the TX input.

[Ordering Information](#) appears at end of data sheet.

**Table 1. Jumper Descriptions**

JUMPER	SHUNT POSITON	DESCRIPTION
J1	1-2*	TXEN is connected to $V_L$ . The C/Q driver is enabled when TXEN = CQEN = $V_L$ .
	2-3	TXEN is connected ground.
J2	1-2*	CQEN is connected to $V_L$ .
	2-3	CQEN is connected to ground.
J3	1-2	CL0 is connected to $V_L$ . CL0 is high.
	2-3*	CL0 is connected to ground. CL0 is low.
J4	1-2	$V_L$ is connected to $V_5$ .
	2-3*	$V_L$ is connected to $V_{33}$ .
J5	1-2*	DOEN is connected to $V_L$ . The DO driver is enabled.
	2-3	DOEN is connected to ground. The DO driver is disabled.
J6	1-2*	AR is connected to $V_L$ . Autoretry is enabled.
	2-3	AR is connected to ground. Autoretry is disabled.
J7	1-2	CL1 is connected to $V_L$ . CL1 is high.
	2-3*	CL1 is connected to ground. CL1 is low.
J9	Open	DI is not connected to pin 2 of the M12 connector (J8).
	Closed*	DI is connected to pin 2 of the M12 connector (J8).
J10	Open	DO is not connected to pin 2 of the M12 connector (J8).
	Closed*	DO is connected to pin 2 of the M12 connector (J8).
J11	Open	$\overline{CQOL}$ is not connected to the DS1 LED circuit.
	Closed*	$\overline{CQOL}$ is connected to the DS1 LED circuit.
J12	Open	$\overline{DOOL}$ is not connected to the DS2 LED circuit.
	Closed*	$\overline{DOOL}$ is connected to the DS2 LED circuit.
J13	Open	$\overline{UV24}$ is not connected to the DS3 LED circuit.
	Closed*	$\overline{UV24}$ is connected to the DS3 LED circuit.
J14	Open	$\overline{LOW24}$ is not connected to the DS4 LED circuit.
	Closed*	$\overline{LOW24}$ is connected to the DS4 LED circuit.

\*Default position.

## Detailed Description of Hardware

The MAX14829 EV kit provides a proven layout for the MAX14829 IO-Link device transceiver.

All the power-supply and regulator input and output pins are connected to convenient connectors for easy probing. The device logic input and output pins are also provided with convenient connectors for logic testing.

The C/Q, DO, and DI pins are protected by TVS diodes.

See [Table 1](#) for a description of all the EV kit jumper configurations.

### Regulators

The MAX14829 includes two regulators:  $V_5$  generates 5V and the  $V_{33}$  regulator generates 3.3V. Use the on-board switch (SW1) to set the configuration for the  $V_5$  regulator:

- Position 1 connects the REG pin to  $V_5$  and the internal 5V regulator is enabled. In this configuration, the  $V_5$  regulator is capable of driving external loads up to 30mA total external load current.
- Position 2 configures  $V_5$  as an input. The internal 5V regulator is disabled and  $V_5$  becomes the supply input for the internal analog and digital functions. Connect an external 5V supply to the  $V_5$  pin on the J4 header. 5V must be present on  $V_5$  for normal operation.
- Position 3 configured the 5V regulator with an external pass transistor, to driver larger external loads. This switch setting connects REG to the base of the transistor to regulate the voltage and connects  $V_5$  to the emitter.

Use jumper J4 to set the logic supply voltage. Connect J4 to 1-2 to set  $V_L = V_5$ . Connect J4 to 2-3 to set  $V_L = V_{33}$ .

**Table 2. Setting the C/Q and DO Current Limit**

CL1	CL0	MAXIMUM DRIVER CURRENT LIMIT
L	L	155mA
L	H	295mA
H	L	365mA
H	H	430mA

**Setting the Driver Current (C/Q and DO)**

Select the current limit for both the C/Q and DO drivers by setting CL1 and CL0 either high or low. Place a shunt on the J7 jumper to set the CL1 input. Place a shunt on the J3 to set the CL0 input. See [Table 2](#).

**Enable/Disable Autoretry Mode (C/Q and DO)**

Set the J6 jumper to 1-2 to enable autoretry functionality on the C/Q and DO drivers. Set J6 to 2-3 to disable autoretry functionality on the drivers.

**Configure the M12 Connector (C/Q, DO, DI)**

The MAX14829 includes a standard 4-pin M12 connection for easy in-circuit evaluation. Pin 1 and pin 3 of the M12 connector are connected to L+ (V<sub>24</sub>) and L- (GND), respectively.

Pin 4 of the M12 connector is connected to the C/Q line.

DI and/or DO can be connected to pin 2 of the M12 connector. Close the J9 jumper to connect the DI input to pin 2. Close the J10 jumper to connect DO to pin 2. Leave J9 and J10 open to leave pin 2 unconnected.

**Fault and Status LEDs**

The  $\overline{\text{CQOL}}$  LED (DS1) turns on when the C/Q driver enters a fault condition. Similarly, the  $\overline{\text{DOOL}}$  LED (DS2) turns on when the DO driver enters a fault condition.  $\overline{\text{CQOL}}$  and  $\overline{\text{DOOL}}$  are high impedance (DS2 and DS3 are off) when the C/Q and DO drivers are operating normally.

The  $\overline{\text{UV24}}$  and  $\overline{\text{LOW24}}$  LEDs (DS3 and DS4, respectively) indicate the status of the V<sub>24</sub> supply. The  $\overline{\text{LOW24}}$  LED (DS4) turns on when V<sub>24</sub> falls below the 16.5V (typ) warning threshold. Both the  $\overline{\text{UV24}}$  and  $\overline{\text{LOW24}}$  LEDs are on when V<sub>24</sub> falls below the 7.2V (typ) V<sub>24</sub> undervoltage lockout (UVLO) threshold.  $\overline{\text{UV24}}$  and  $\overline{\text{LOW24}}$  deassert, and the LEDs turn off, when the V<sub>24</sub> voltage is above the UVLO and warning thresholds, respectively.

**On-Board Protection**

The MAX14829 EV kit includes on-board TVS diodes to protect the C/Q, DO, and DI lines against transient high-voltage surge and EFT events up to ±1kV/500Ω. Larger diodes are required to protect against higher voltage/current events. SMB sized pads are included on the EV kit for evaluation with larger diodes.

**Ordering Information**

PART	TYPE
MAX14829EVKIT#	EV Kit

#Denotes RoHS compliant.

MAX14829 EV Kit Bill of Materials

ITEM	REF_DES	DNI/DNP	QTY	MFG PART #	MANUFACTURER	VALUE	DESCRIPTION
1	C1, C2	-	2	C0402C105K8PAC; CC0402KRX5R6BB105	KEMET;YAGEO	1UF	CAPACITOR; SMT (0402); CERAMIC CHIP; 1UF; 10V; TOL=10%; TG=-55 DEGC TO +85 DEGC; TC=X5R
2	C3	-	1	CC0603KRX7R0BB104; GRM188R72A104KA35; GCJ188R72A104KA01; HMK107B7104KA; 06031C104KAT2A	YAGEO;MURATA;MURATA; TAIYO YUDEN;AVX	0.1UF	CAPACITOR; SMT (0603); CERAMIC CHIP; 0.1UF; 100V; TOL=10%; TG=-55 DEGC TO +125 DEGC; TC=X7R
3	C4	-	1	C0402C104J4RAC; GCM155R71C104JA55	KEMET;MURATA	0.1UF	CAPACITOR; SMT (0402); CERAMIC CHIP; 0.1UF; 16V; TOL=5%; MODEL=; TG=-55 DEGC TO +125 DEGC; TC=X7R
4	C5-C8	-	4	C0402C331J5GAC; GRM1555C1H331JA01	KEMET;MURATA	330PF	CAPACITOR; SMT (0402); CERAMIC CHIP; 330PF; 50V; TOL=5%; TG=-55 DEGC TO +125 DEGC; TC=C0G
5	D1, D3	-	2	SPT02-236DDB	ST MICROELECTRONICS	SPT02-236DDB	DIODE; TVS; UQFN-2L; PIV=38V; IF=0.3A
6	D2	-	1	SPT01-335DEE	ST MICROELECTRONICS	SPT01-335DEE	DIODE; TVS; QFN6; PIV=38V; IF=0.3A
7	D5	-	1	ZHCS506	DIODES INCORPORATED	ZHCS506TA	DIODE; SCH; SMT (SOT-23); PIV=60V; IF=0.5A
8	DS1-DS4	-	4	SML-311UT	ROHM	SML-311UTT86	DIODE; LED; LOW CURRENT; SMT (0603); VF=1.8V; IF=0.02A; -30 DEGC TO +85 DEGC; RED
9	J1-J7	-	7	TSW-103-07-T-S	SAMTEC	TSW-103-07-T-S	CONNECTOR; THROUGH HOLE; TSW SERIES; SINGLE ROW; STRAIGHT; 3PINS
10	J8	-	1	09 0431 212 04	BINDER	09 0431 212 04	CONNECTOR; MALE; TH; MALE RECEPTACLE; THREADED; PCB SOLDER; STRAIGHT; 4PINS;
11	J9-J14	-	6	TSW-102-07-T-S	SAMTEC	TSW-102-07-T-S	CONNECTOR; THROUGH HOLE; TSW SERIES; SINGLE ROW; STRAIGHT; 2PINS; -55 DEGC TO +105 DEGC
12	Q1	-	1	BCP56TA	DIODES INCORPORATED	BCP56TA	TRAN; NPN SILICON PLANAR MEDIUM POWER TRANSISTOR; NPN; SOT-223; PD-(2.0W); I-(1A); V-(80V)
13	R1, R12-R14	-	4	RCRW0402560RFK; RC0402FR-0756ORL	VISHAY DALE; YAGEO PHICOMP	560	RESISTOR; 0402; 560 OHM; 1%; 100PPM; 0.063W; THICK FILM
14	R2-R6, R16-R21	-	11	RC0402JR-070RL; CR0402-16W-000RJT	YAGEO PHYCOMP; VENKEL LTD.	0	RESISTOR; 0402; 0 OHM; 5%; JUMPER; 0.063W; THICK FILM
15	R7	-	1	RCRW04021K00FK; RC0402FR-071KL; MCR01MZPF1001	VISHAY DALE; YAGEO PHICOMP; ROHM SEMI	1K	RESISTOR; 0402; 1K; 1%; 100PPM; 0.0625W; THICK FILM
16	R9, R10	-	2	RCRW040210K0FK; RC0402FR-0710KL	VISHAY DALE; YAGEO PHICOMP	10K	RESISTOR; 0402; 10K; 1%; 100PPM; 0.0625W; THICK FILM
17	SU1-SU13	-	13	QPC02SXGN-RC	SULLINS ELECTRONICS CORP.	QPC02SXGN-RC	CONNECTOR; FEMALE; 0.100IN CC; OPEN TOP; JUMPER; STRAIGHT; 2PINS
18	SW1	-	1	MHS231	COPAL ELECTRONICS INC	MHS231	SWITCH; DP3T; THROUGH HOLE; STRAIGHT; 12V; 0.2A; MHS SERIES; HYPER-MINIATURE SLIDE SWITCH; RCOIL=0 OHM; RINSULATION=100M OHM
19	TP1	-	1	5010	KEYSTONE	N/A	TEST POINT; PIN DIA=0.125IN; TOTAL LENGTH=0.445IN; BOARD HOLE=0.063IN; RED; PHOSPHOR BRONZE WIRE SIL;
20	TP2, TP12, TP18, TP24, TP26	-	5	5011	KEYSTONE	N/A	TEST POINT; PIN DIA=0.125IN; TOTAL LENGTH=0.445IN; BOARD HOLE=0.063IN; BLACK; PHOSPHOR BRONZE WIRE SILVER PLATE FINISH;
21	TP3	-	1	571-0500	DELTRON	571-0500	CONNECTOR; FEMALE; THROUGH HOLE; BANANA 4MM SOCKET; RIGHT ANGLE; 2PINS
22	TP4	-	1	571-0100	DELTRON	571-0100	CONNECTOR; FEMALE; THROUGH HOLE; BANANA 4MM SOCKET; RIGHT ANGLE; 2PINS
23	TP7-TP9, TP13-TP15, TP19-TP21	-	9	5014	KEYSTONE	N/A	TEST POINT; PIN DIA=0.125IN; TOTAL LENGTH=0.445IN; BOARD HOLE=0.063IN; YELLOW; PHOSPHOR BRONZE WIRE SILVER PLATE FINISH;
24	U1	-	1	MAX14829ATG+	MAXIM	MAX14829ATG+	IC; TXRX; MAX14829ATG+; LOW-POWER DUAL DRIVER IO-LINK DEVICE TRANSCEIVER; PACKAGE CODE: T2444+4; PACKAGE OUTLINE NUMBER: 21-0139; LAND PATTERN NUMBER: 90-0022; TQFN24-EP
25	PCB	-	1	MAX14829	MAXIM	PCB	PCB:MAX14829
26	D4, D6-D9	DNP	0	SMBJ33A	ST MICROELECTRONICS	33V	DIODE; TVS; SMB (DO-214AA); VRM=33V; IPP=11.8A
27	U2	DNP	0	ARDUINO_UNO_R3	ARDUINO	ARDUINO_UNO_R3	MODULE; ARDUINO_UNO_R3
TOTAL			82				

MAX14829 EV Kit Schematic

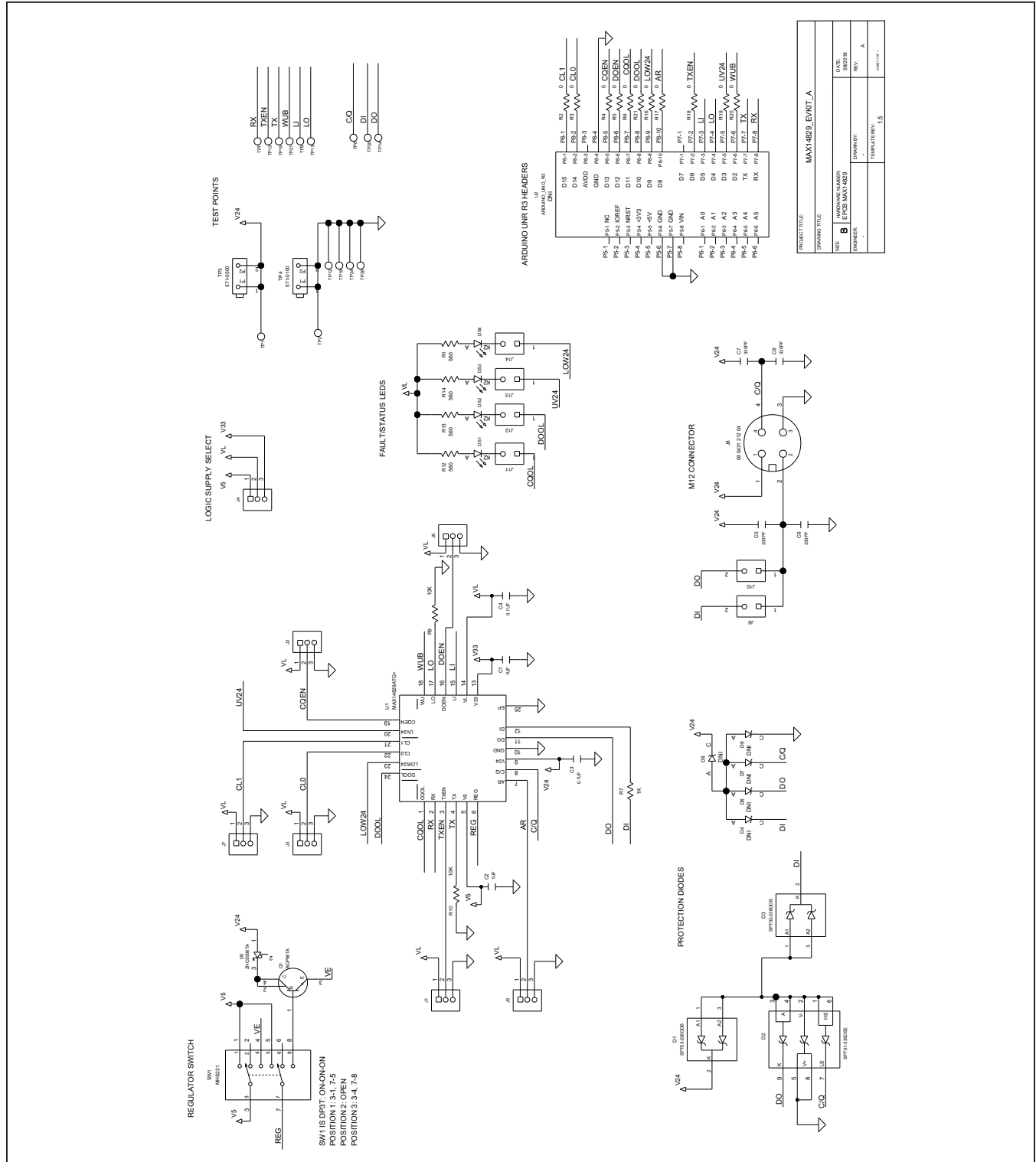

MAX14829 EV Kit PCB Layout Diagrams

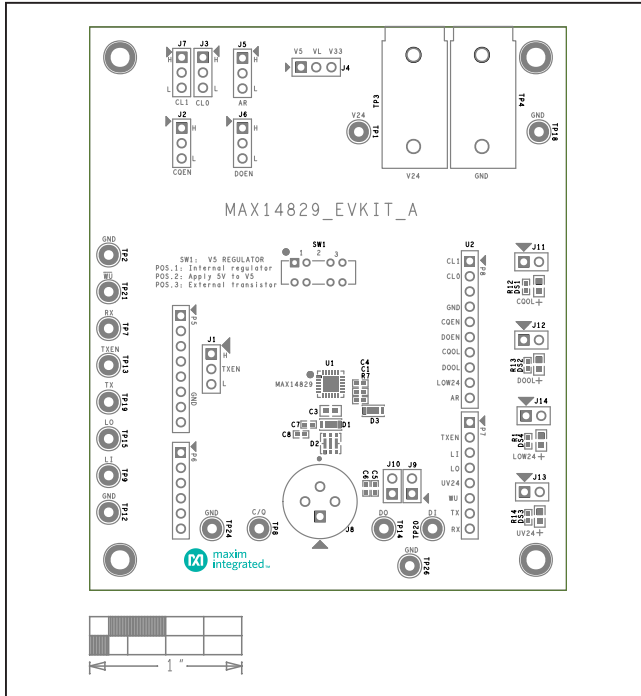

MAX14829 EV Kit—Top Silkscreen

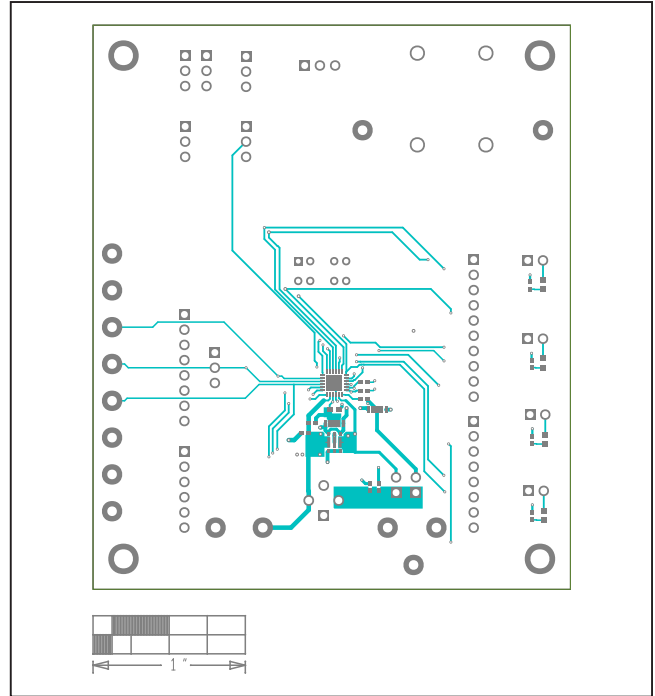

MAX14829 EV Kit—Top

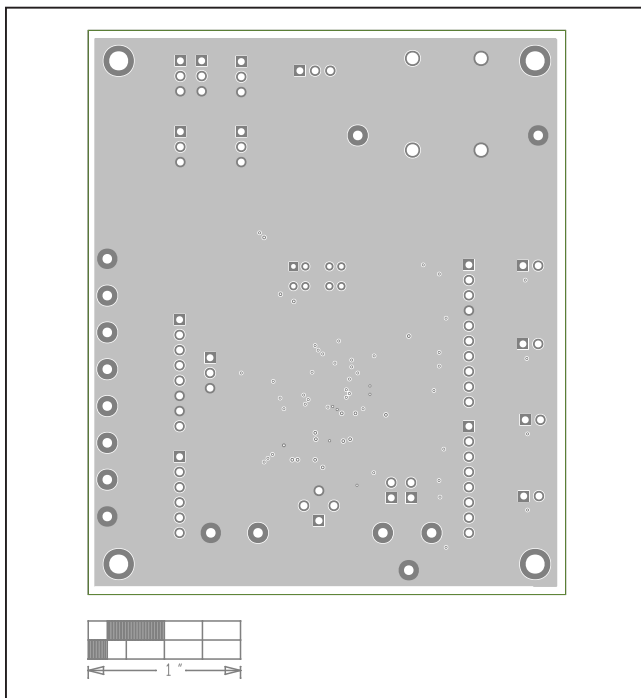

MAX14829 EV Kit—Internal 2

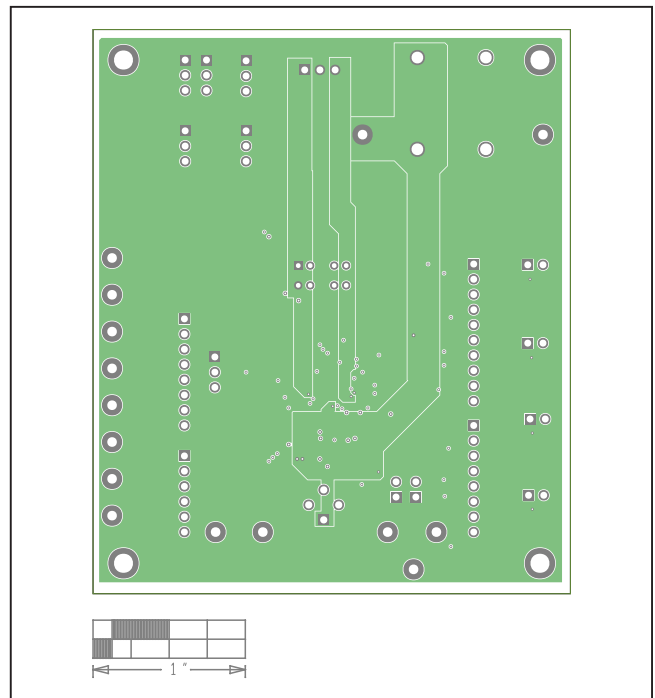

MAX14829 EV Kit—Internal 3

MAX14829 EV Kit PCB Layout Diagrams (continued)

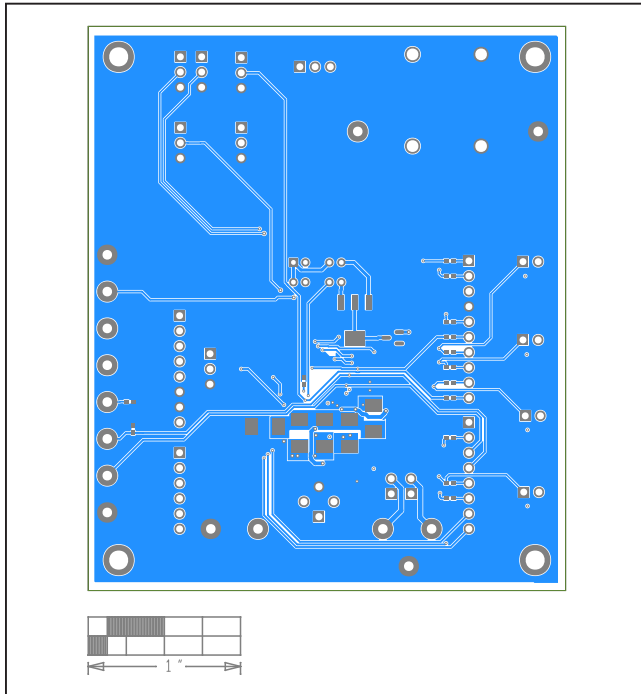

MAX14829 EV Kit—Bottom

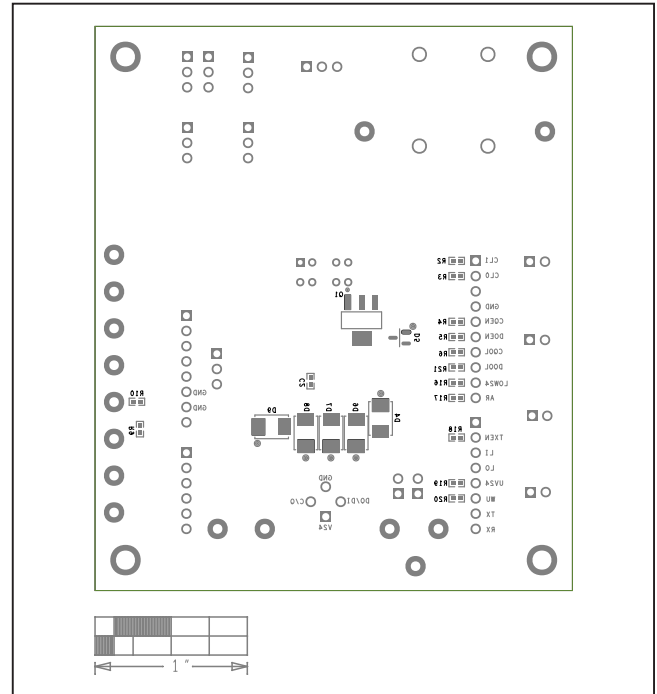

MAX14829 EV Kit—Bottom Silkscreen