

# MAX14830 Evaluation Kit

## Evaluates: MAX14830

### General Description

The MAX14830 evaluation kit (EV kit) provides a proven design to evaluate the MAX14830 quad-channel universal asynchronous receiver-transmitter (UART) IC. Each UART contains 128 words of receive and transmit first-in/first-out (FIFO) buffer that can be controlled through the SPI or I<sup>2</sup>C interface. Each of the four UARTs are selected through SPI or I<sup>2</sup>C in-band addressing.

Each of the four UARTs can interface with an IO-Link<sup>®</sup> master transceiver or an RS-485/RS-232 multiprotocol transceiver. The EV kit contains on-board IO-Link master transceivers, RS-485/RS-232 multiprotocol transceivers, and double-pole/double-throw (DPDT) switches are used to select between the IO link and RS-485/RS-232 transceivers.

The EV kit operates from a +3.3V and a +24V DC supply and requires 100mA of current from each supply. This EV kit requires a user-supplied SPI/I<sup>2</sup>C controller and software.

The EV kit comes with a MAX14830ETM+ installed.

### Features

- ◆ +3.3V and +24V Power-Supply Operation
- ◆ On-Board IO-Link Master Transceivers (MAX14824)
- ◆ On-Board RS-485/RS-232 Multiprotocol Transceivers (MAX3160E)
- ◆ PCB Header for User-Supplied SPI- and I<sup>2</sup>C-Compatible Signals
- ◆ PCB Headers for UART Signals (J1)
- ◆ Evaluates the MAX14830 in a 48-Pin TQFN (7mm x 7mm) Package
- ◆ RoHS Compliant
- ◆ Proven PCB Layout
- ◆ Fully Assembled and Tested

[Ordering Information](#) appears at end of data sheet.

### Component List

DESIGNATION	QTY	DESCRIPTION
AARDVARK	1	10-pin (2 x 5) header
C1	1	10µF ±20%, 50V X7R ceramic capacitor (2220) TDK C5750X7R1H106M
C2	1	10µF ±10%, 6.3V X7R ceramic capacitor (0805) Murata GRM21BR70J106K
C3–C6, C8–C11, C20, C22, C24, C26	12	1µF ±10%, 10V X7R ceramic capacitors (0603) Murata GRM188R71A105K
C12–C15	4	1µF ±10%, 50V X7R ceramic capacitors (0805) Murata GRM21BR71H105K
C16–C19, C21, C23, C25, C27–C42	23	0.1µF ±10%, 50V X7R ceramic capacitors (0603) Murata GRM188R71H104K
C43, C45, C47, C49	4	270pF ±5%, 50V C0G ceramic capacitors (0603) TDK C1608C0G1H271J
C44, C46, C48, C50	4	1nF ±5%, 50V X7R ceramic capacitors (0603) KEMET C0603C102J5RACTU

DESIGNATION	QTY	DESCRIPTION
D1–D12	12	Green LEDs (0603)
D13, D14, D17, D18, D21, D22, D25, D26	8	40V, 2A Schottky diodes Diodes, Inc. DFLS240
D15, D19, D23, D27, D29	5	33V, 4A TVS diodes (SOT23) Semtech SDC36C.TCT
GPIO	1	5-pin header
IOLINK0–IOLINK3	4	4-pin headers
J1	1	2 x 24 right-angle socket strip
JU1–JU10	10	2-pin headers
JU11–JU17	7	3-pin headers
JU18, JU19	2	4-way, 5-pin headers
JU20	0	Not installed, 2-pin header
R1–R4	4	1kΩ ±5% resistors (0603)
R5–R10	6	2kΩ ±5% resistors (0603)
R11–R26	16	10kΩ ±5% resistors (0603)
R27	1	0.5Ω ±5% resistor (2010) IRC LRC-LR2010LF-01-R500-J
RS0–RS3	4	6-pin headers
SPI/I <sup>2</sup> C	1	12-pin header

IO-Link is a registered trademark of Profibus User Organization (PNO).

**For pricing, delivery, and ordering information, please contact Maxim Direct at 1-888-629-4642, or visit Maxim's website at [www.maxim-ic.com](http://www.maxim-ic.com).**

# MAX14830 Evaluation Kit

## Evaluates: MAX14830

### Component List (continued)

DESIGNATION	QTY	DESCRIPTION
SW1	1	Momentary pushbutton switch
U1	1	Quad SPI/I <sup>2</sup> C UART with 128-word FIFOs (48 TQFN-EP) Maxim MAX14830ETM+
U2, U3	2	Quad DPDT switches (36 TQFN-EP) Maxim MAX4761ETX+
U4-U7	4	IO-Link master transceivers (24 TQFN-EP) Maxim MAX14824GTG+

DESIGNATION	QTY	DESCRIPTION
U8-U11	4	Multiprotocol transceivers (20 SSOP) Maxim MAX3160EEAP+
U12	1	SPDT analog switch (6 SOT23) Maxim MAX4624EUT+ (Top Mark: AADL)
Y1	1	3.6864MHz crystal
—	19	Shunts
—	1	PCB: MAX14830 EVALUATION KIT

### Component Suppliers

SUPPLIER	PHONE	WEBSITE
Diodes Incorporated	805-446-4800	www.diodes.com
IRC, Inc.	361-992-7900	www.irctt.com
KEMET Corp.	864-963-6300	www.kemet.com
Murata Electronics North America, Inc.	770-436-1300	www.murata-northamerica.com
Semtech Corporation	805-495-2111	www.semtech.com
TDK Corp.	847-803-6100	www.component.tdk.com

**Note:** Indicate that you are using the MAX14830 when contacting these component suppliers.

### Quick Start

#### Required Equipment

- MAX14830 EV kit
- User-supplied SPI interface controller
- +3.3V, 100mA DC power supply
- +24V, 100mA DC power supply

#### Procedure

The EV kit is fully assembled and tested. Follow the steps below to verify board operation. **Caution: Do not turn on the power supply until all connections are completed.**

- 1) Verify that shunts are installed in their default positions, as shown in Table 1.
- 2) Connect the output of the SPI interface controller to the SPI/I<sup>2</sup>C 12-pin header, as follows:
  - Connect CSN to pin 5 of SPI/I<sup>2</sup>C
  - Connect MISO to pin 6 of SPI/I<sup>2</sup>C
  - Connect SCLK to pin 7 of SPI/I<sup>2</sup>C
  - Connect MOSI to pin 10 of SPI/I<sup>2</sup>C
- 3) Turn on the +3.3V power supply and set the supply to +3.3V, then disable the power supply.
- 4) Connect the positive terminal of the +3.3V power supply to the +3.3V PCB pad on the EV kit. Connect the negative terminal of the power supply to the GND PCB pad.
- 5) Turn on the +24V power supply and set the supply to +24V, then disable the power supply.
- 6) Connect the positive terminal of the +24V power supply to the +24V PCB pad on the EV kit. Connect the negative terminal of the power supply to the GND PCB pad.
- 7) Enable both power supplies.
- 8) Send SPI signals to the EV kit through the SPI/I<sup>2</sup>C 12-pin header.
- 9) Detect the output at the IOLINK1-IOLINK4 4-pin headers.
- 10) The EV kit is now ready for additional testing.

# MAX14830 Evaluation Kit

## Evaluates: MAX14830

**Table 1. Default Shunt Positions (JU1–JU19)**

JUMPER	SHUNT POSITION	PIN CONNECTION	EV KIT FUNCTION
JU1	Not installed	U1, pin 1 (SPI/I <sup>2</sup> C) connected to +3.3V through resistor R11.	SPI mode.
JU2	Not installed	U2, pin 4 and U3, pin 4 (INA) connected to GND through resistor R12.	IO link selected.
JU3–JU10	Not installed	D5–D12 (anodes) not connected.	D5–D12 not used.
JU11	1-2	U12, pin 1 (IN) connected to +3.3V.	SPI/I <sup>2</sup> C header, pin 5 (CSN) connected to JU19, pin 3 (CS).
JU12	1-2	SPI/I <sup>2</sup> C header, pin 6 (MISO) connected to U1, pin 3.	U1 connected to SPI interface controller (MISO).
JU13	1-2	SPI/I <sup>2</sup> C header, pin 7 (SCLK) connected to U1, pin 4.	U1 connected to SPI interface controller (SCLK).
JU14–JU17	1-2	Install shunts in the 1-2 default position (JU14–JU17 are “don’t care” when operating in SPI mode).	
JU18	1-3	SPI/I <sup>2</sup> C header, pin 10 (MOSI) connected to U1, pin 6.	U1 connected to SPI interface controller (MOSI).
JU19	1-3	U12, pin 6 (CS) connected to U1, pin 5.	U1 connected to SPI interface controller (CSN).

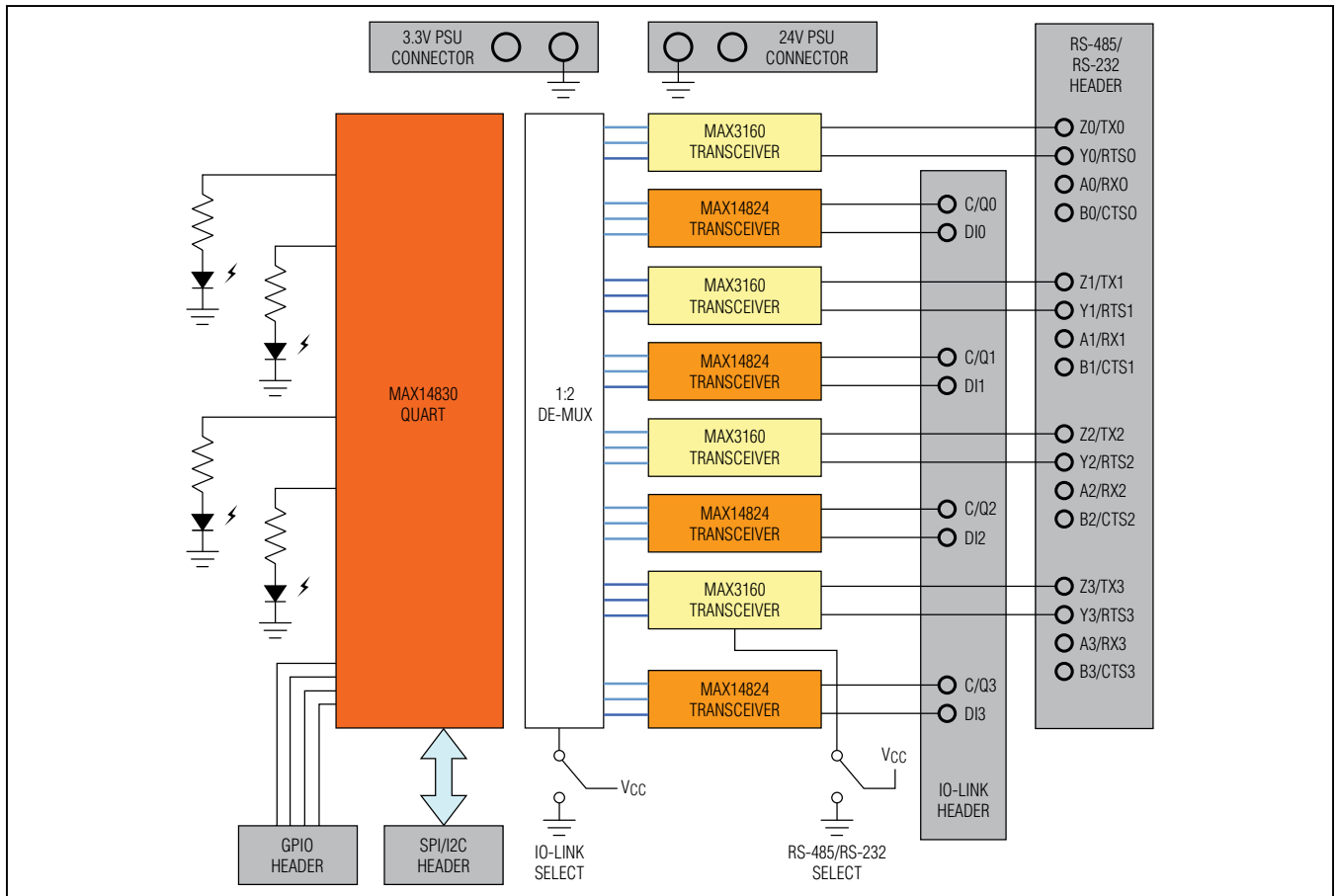

Figure 1. System Setup Example

# MAX14830 Evaluation Kit

## Evaluates: MAX14830

### Detailed Description of Hardware

The MAX14830 EV kit provides a proven design to evaluate the MAX14830 IC. The IC is an advanced quad-channel UART with each UART containing 128 words of receive and transmit FIFO buffer that can be controlled through SPI or I<sup>2</sup>C. Each of the four UARTs is selected through SPI or I<sup>2</sup>C in-band addressing.

Each of the four UARTs can interface with an IO-Link master transceiver or an RS-485/RS-232 multiprotocol transceiver. The EV kit contains four on-board IO-Link master transceivers, four RS-485/RS-232 multiprotocol transceivers, and 8-channel DPDT switches to select between the IO link and RS-485/RS-232 transceivers.

### Jumper Selection

#### SPI/I<sup>2</sup>C Operating Mode (SPI/I<sup>2</sup>C)

Jumper JU1 selects the IC's operating mode. The operating mode is selectable between SPI and I<sup>2</sup>C. See Table 2 for JU1 shunt positions.

**Table 2. JU1 Jumper Selection (SPI/I<sup>2</sup>C)**

SHUNT POSITION	U1-1 (SPI/I <sup>2</sup> C) CONNECTED TO	OPERATING MODE
Not installed*	+3.3V (through resistor R11)	SPI
Installed	GND	I <sup>2</sup> C

\*Default position.

**Table 3. JU2 Jumper Selection (INA)**

SHUNT POSITION	U2-4 AND U3-4 (INA) CONNECTED TO	OUTPUT INTERFACE
Not installed*	GND (through resistor R12)	IO link
Installed	+3.3V	RS-485/RS-232

\*Default position.

**Table 5. JU11 Jumper Selection (CSN)**

SHUNT POSITION	U12-1 (IN) CONNECTED TO	SPI/I <sup>2</sup> C HEADER, PIN 5 (CSN) CONNECTED TO	CSN SERVING
1-2*	+3.3V	U1, pin 5 ( $\overline{CS}/A0$ ) (through jumper JU19)	UART
2-3	GND	U4-U7, pin 6 ( $\overline{CS}$ )	IO links
Not installed	SPI/I <sup>2</sup> C header, pin 11 (CSN_SEL)	CSN connection selected by CSN_SEL	Determined by CSN_SEL

\*Default position.

### IO Link and RS-485/RS-232 Output Interface Selection (INA)

Jumper JU2 selects the IC's output interface. The output interface is selectable between the IO link and RS-485/RS-232 transceivers. See Table 3 for JU2 shunt positions.

### IO-Link Signal Indicators ((C/Q)/(DI))

Jumpers JU3-JU10 connect or disconnect the IO-Link signal (C/Q)/(DI) from their respective LED indicators. Install shunts to connect or remove shunts to disconnect the IO-Link signal from their respective LED indicators. Table 4 lists the correspondence between jumpers JU3-JU10 to their respective IO-Link signal and LED indicators.

### UART and IO-Link Chip-Select Signal (CSN)

Jumper JU11 selects the destination for the CSN (chip-select signal on the SPI/I<sup>2</sup>C header, pin 5). The CSN chip-select signal can be set to serve either the UART (MAX14830) or the four IO links (MAX14824) using JU11. See Table 5 for JU11 shunt positions.

**Table 4. JU3-JU10 Jumper Legend (LEDs)**

JUMPER*	SIGNAL/POWER	LED
JU3	IOLINK0 C/Q	D5
JU4	IOLINK0 DI	D6
JU5	IOLINK1 C/Q	D7
JU6	IOLINK1 DI	D8
JU7	IOLINK2 C/Q	D9
JU8	IOLINK2 DI	D10
JU9	IOLINK3 C/Q	D11
JU10	IOLINK3 DI	D12

\*Install shunts to connect or remove (default) shunts to disconnect from LED.

# MAX14830 Evaluation Kit

## Evaluates: MAX14830

### MISO/SDA

Jumper JU12 configures the MISO/SDA pin (U1, pin 3) and routes the signal to the respective headers. See Table 6 for JU12 shunt positions.

### SCLK/SCL

Jumper JU13 configures the SCLK/SCL pin (U1, pin 4) and routes the signal to the respective headers. See Table 7 for JU13 shunt positions.

### MOSI/A1

Jumpers JU14 and JU18 configure the MOSI/A1 pin (U1, pin 6). See Table 8 for JU14 and JU18 shunt positions.

### $\overline{\text{CS/A0}}$

Jumpers JU15 and JU19 configure the  $\overline{\text{CS/A0}}$  pin (U1, pin 5). See Table 9 for JU15 and JU19 shunt positions.

**Table 6. JU12 Jumper Selection (MISO/SDA)**

SHUNT POSITION	MISO/SDA PIN CONNECTED TO	OPERATING MODE
1-2*	SPI/ $\overline{\text{I2C}}$ header, pin 6 (MISO)	SPI
2-3	SPI/ $\overline{\text{I2C}}$ header, pin 9 (SDA)	I <sup>2</sup> C
Not installed	Not connected	Not selected

\*Default position.

**Table 7. JU13 Jumper Selection (SCLK/SCL)**

SHUNT POSITION	SCLK/SCL PIN CONNECTED TO	OPERATING MODE
1-2*	SPI/ $\overline{\text{I2C}}$ header, pin 7 (SCLK)	SPI
2-3	SPI/ $\overline{\text{I2C}}$ header, pin 8 (SCL)	I <sup>2</sup> C
Not installed	Not connected	Not selected

\*Default position.

**Table 8. JU14 and JU18 Jumper Selection (MOSI/A1)**

SHUNT POSITION		MOSI/A1 PIN CONNECTED TO	OPERATING MODE
JU18	JU14		
1-3	Not used	SPI/ $\overline{\text{I2C}}$ header, pin 10 (MOSI)	SPI
1-2	Not used	+3.3V	I <sup>2</sup> C*
1-5	Not used	GND	
1-4	1-2	SPI/ $\overline{\text{I2C}}$ header, pin 9 (SDA)	
	2-3	SPI/ $\overline{\text{I2C}}$ header, pin 8 (SCL)	
Not installed	Not used	Not connected	Not selected

\*Refer to the MAX14830 IC data sheet for the corresponding I<sup>2</sup>C slave address.

**Table 9. JU15 and JU19 Jumper Selection ( $\overline{\text{CS/A0}}$ )**

SHUNT POSITION		$\overline{\text{CS/A0}}$ PIN CONNECTED TO	OPERATING MODE
JU19	JU15		
1-3	Not used	SPI/ $\overline{\text{I2C}}$ header, pin 5 (CSN) (with shunt installed on pins 1-2 of JU11)	SPI
1-2	Not used	+3.3V	I <sup>2</sup> C*
1-5	Not used	GND	
1-4	1-2	SPI/ $\overline{\text{I2C}}$ header, pin 9 (SDA)	
	2-3	SPI/ $\overline{\text{I2C}}$ header, pin 8 (SCL)	
Not installed	Not used	Not connected	Not selected

\*Refer to the MAX14830 IC data sheet for the corresponding I<sup>2</sup>C slave address.

# MAX14830 Evaluation Kit

## Evaluates: MAX14830

### **RS-485/RS-232 Selection**

Jumper JU16 selects between the RS-485 and RS-232 output protocols for the EV kit. See Table 10 for JU16 shunt positions.

**Table 10. JU16 Jumper Selection (RS-485/RS-232)**

SHUNT POSITION	RS-485/RS-232 PINS CONNECTED TO	OUTPUT PROTOCOL
1-2*	+3.3V	RS-485
2-3	GND	RS-232
Not installed	Not connected	Not selected

\*Default position.

### **Half Duplex and Full Duplex (HDPLX)**

Jumper JU17 selects either a half-duplex or full-duplex output protocol for the EV kit. See Table 11 for JU17 shunt positions.

**Table 11. JU17 Jumper Selection (HDPLX)**

SHUNT POSITION	HDPLX PINS CONNECTED TO	OUTPUT PROTOCOL
1-2*	+3.3V	Half duplex
2-3	GND	Full duplex
Not installed	Not connected	Not selected

\*Default position.



# MAX14830 Evaluation Kit

## Evaluates: MAX14830

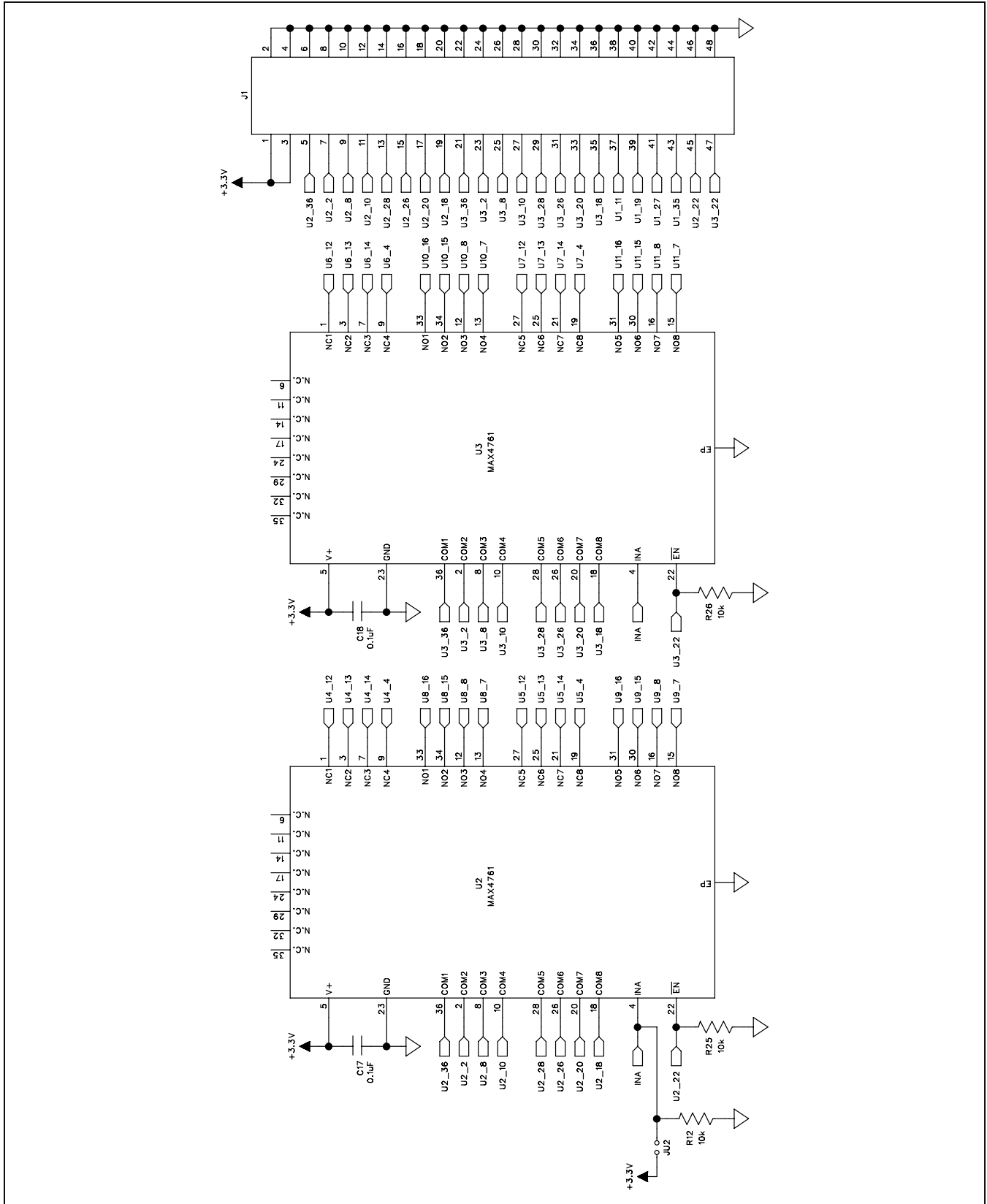

Figure 2b. MAX14830 EV Kit Schematic (Sheet 2 of 4)



# MAX14830 Evaluation Kit

## Evaluates: MAX14830

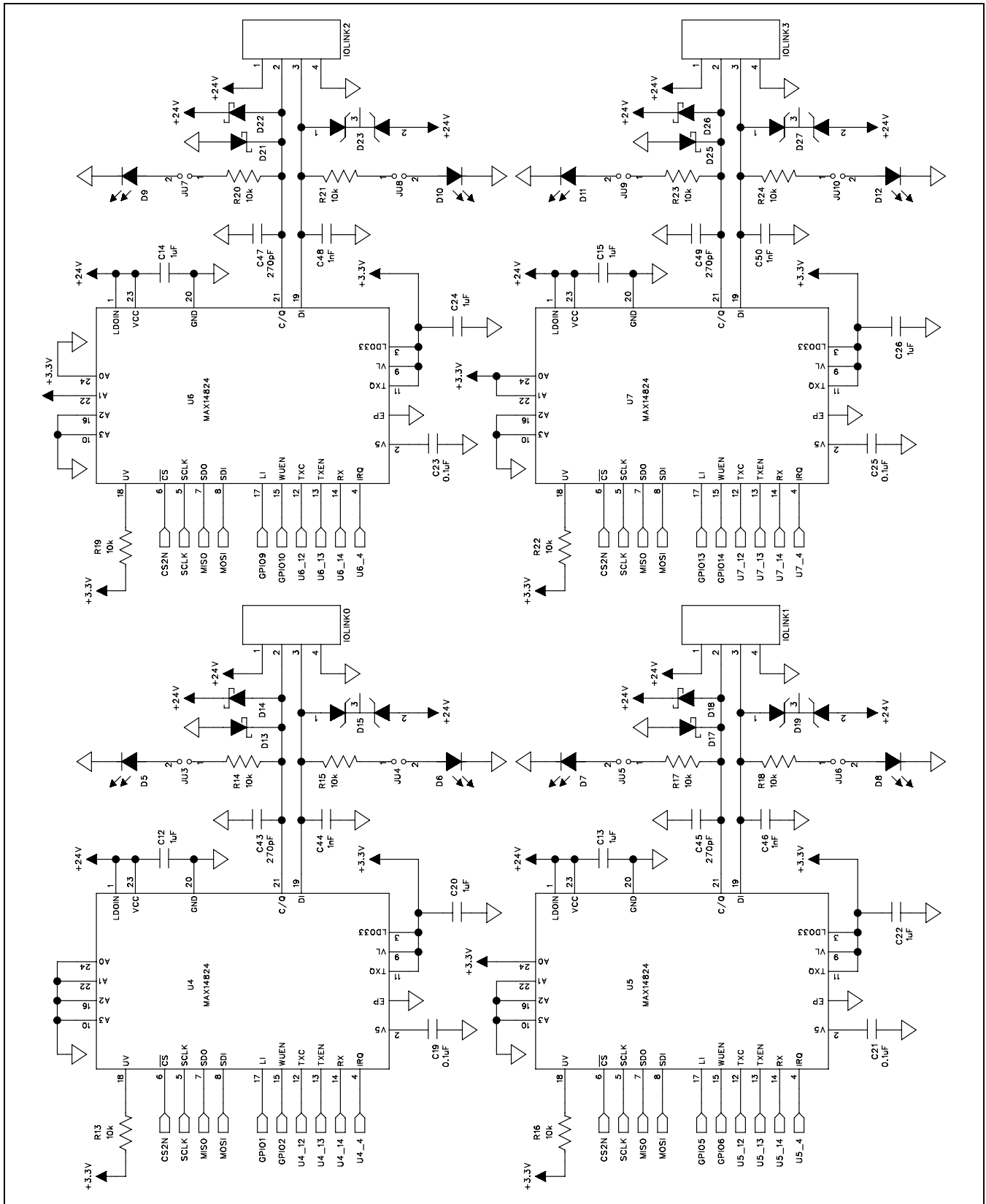

Figure 2c. MAX14830 EV Kit Schematic (Sheet 3 of 4)

# MAX14830 Evaluation Kit

## Evaluates: MAX14830

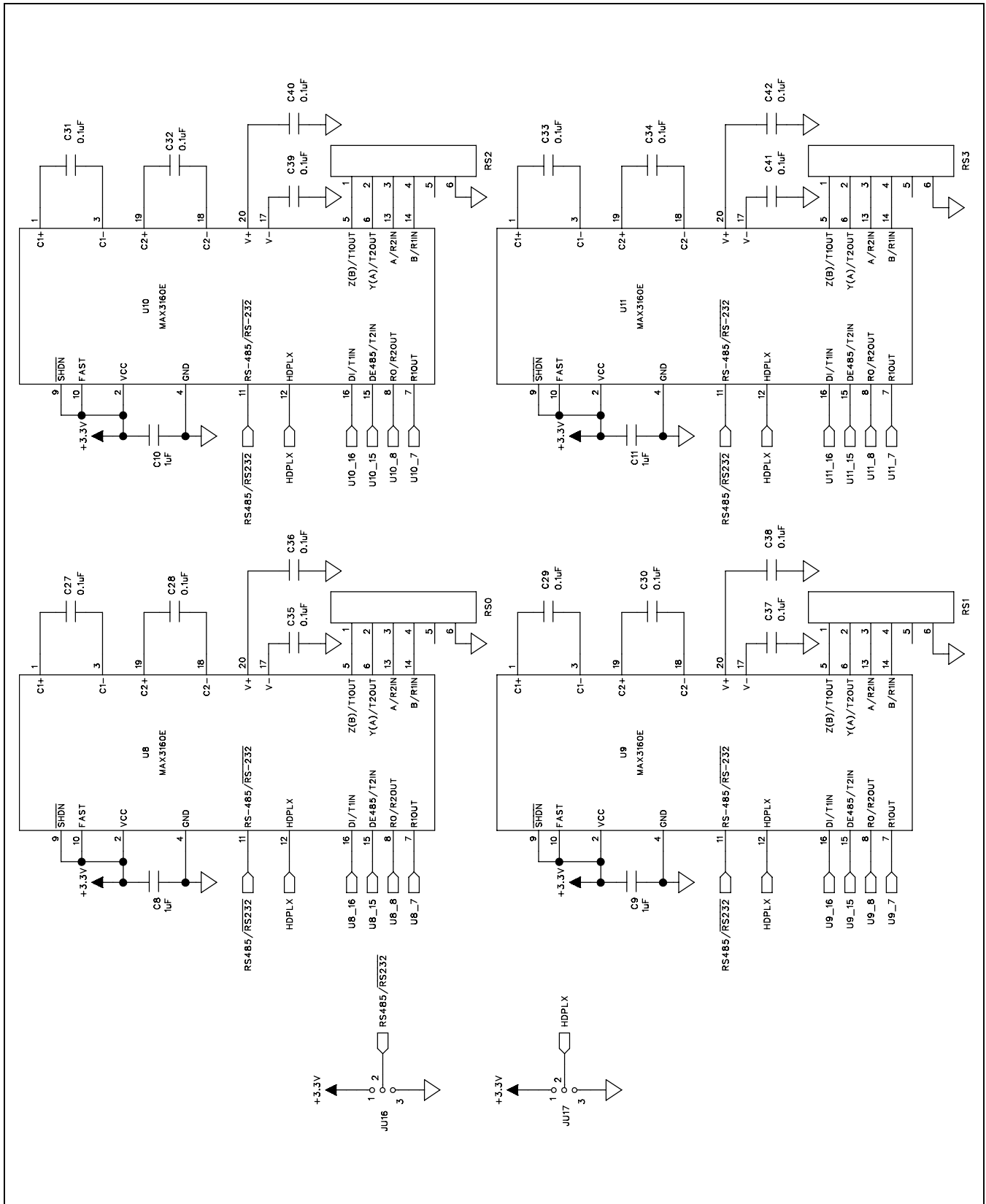

Figure 2d. MAX14830 EV Kit Schematic (Sheet 4 of 4)

# MAX14830 Evaluation Kit

## Evaluates: MAX14830

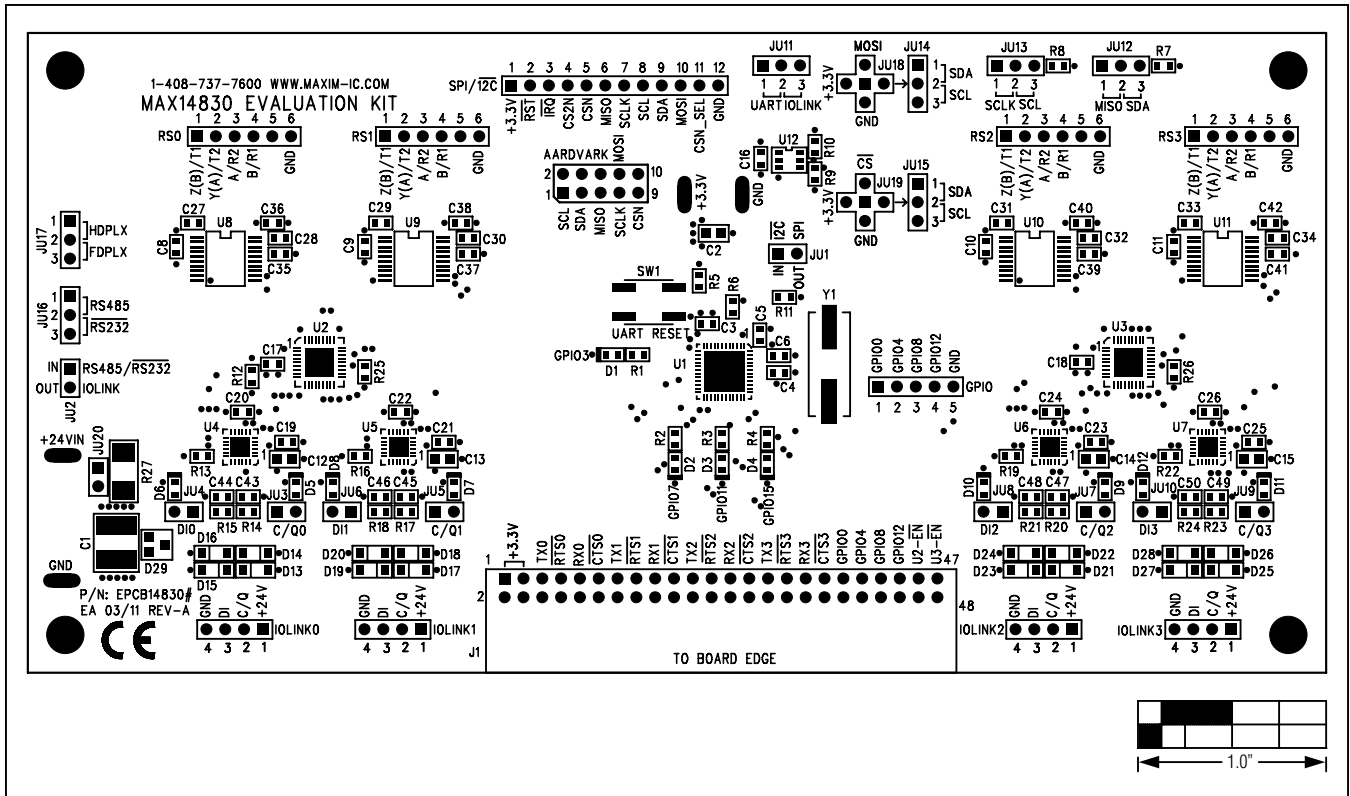

Figure 3. MAX14830 EV Kit Component Placement Guide—Component Side

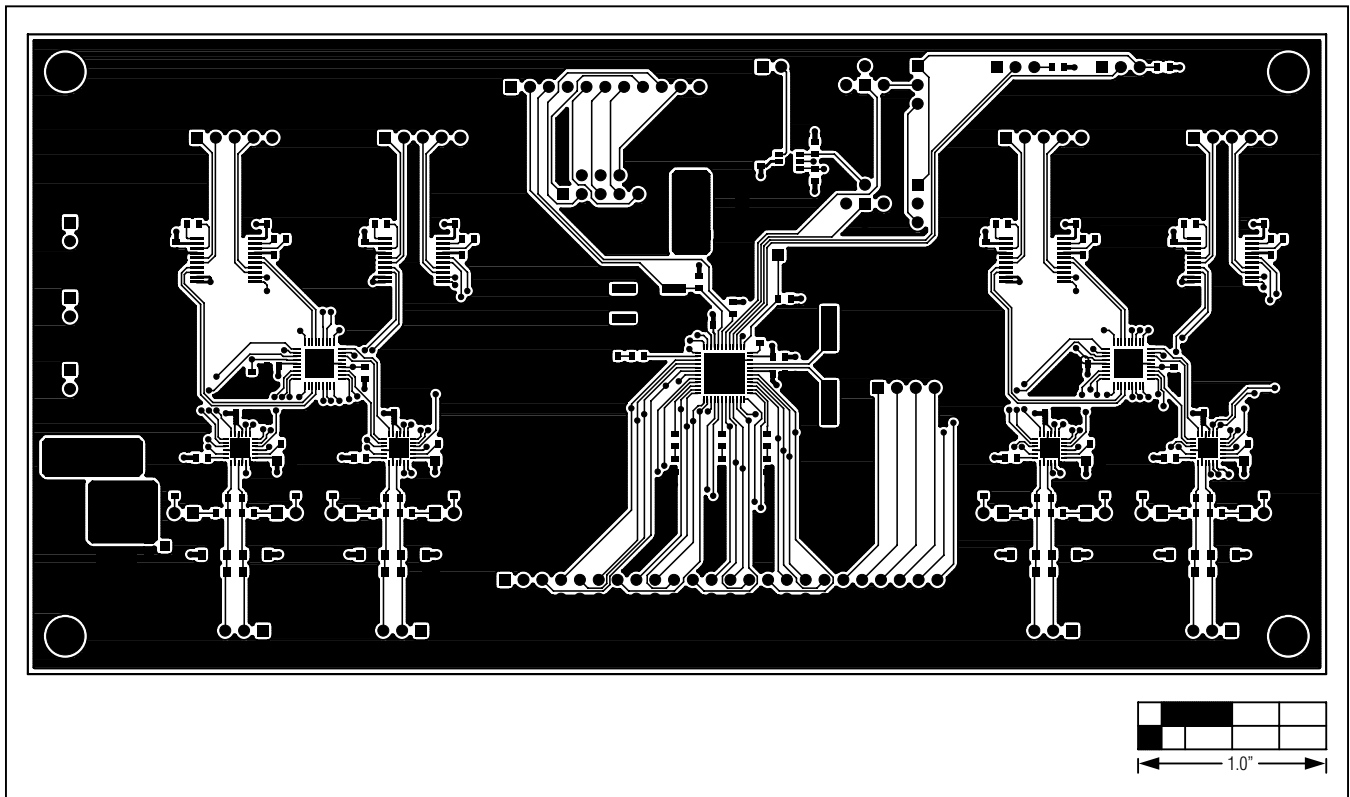

Figure 4. MAX14830 EV Kit PCB Layout—Component Side

# MAX14830 Evaluation Kit

## Evaluates: MAX14830

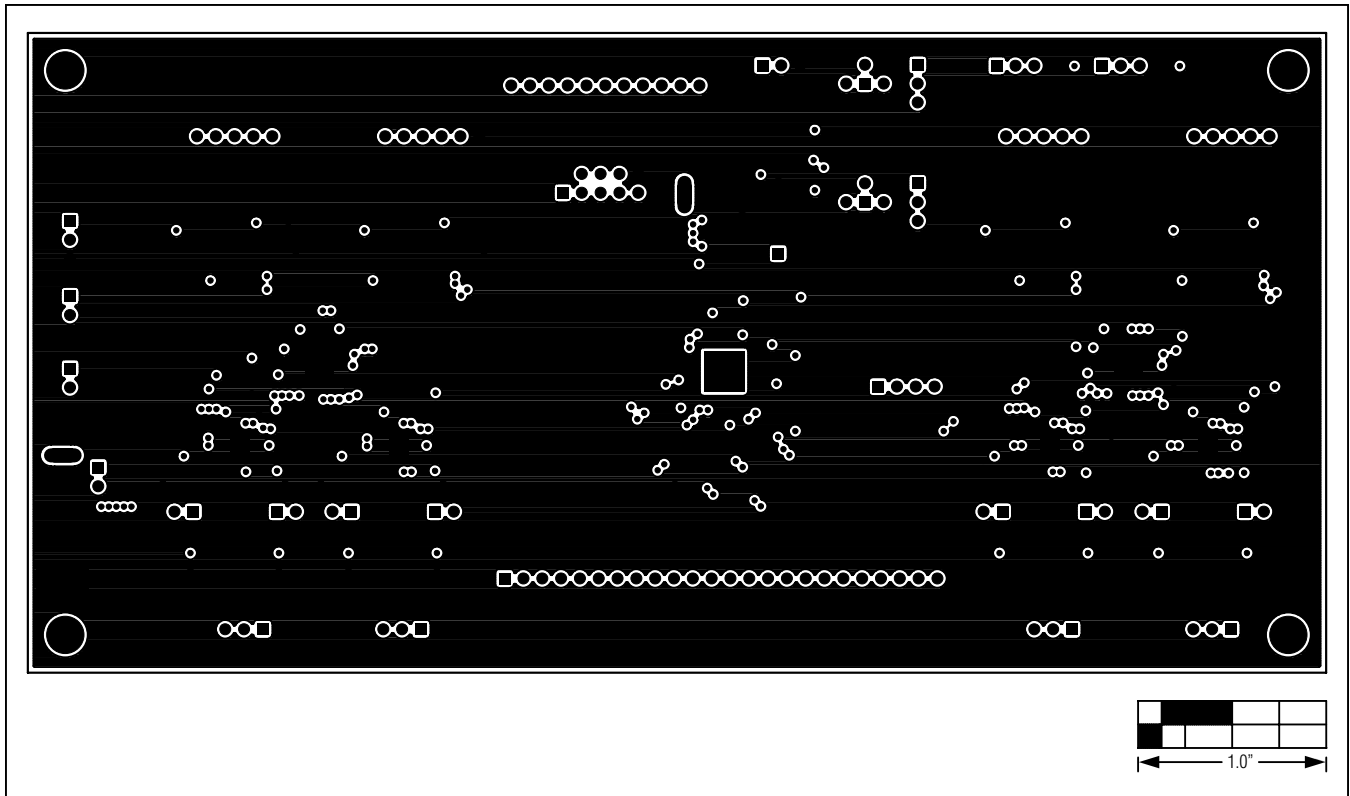

Figure 5. MAX14830 EV Kit PCB Layout—GND Layer 2

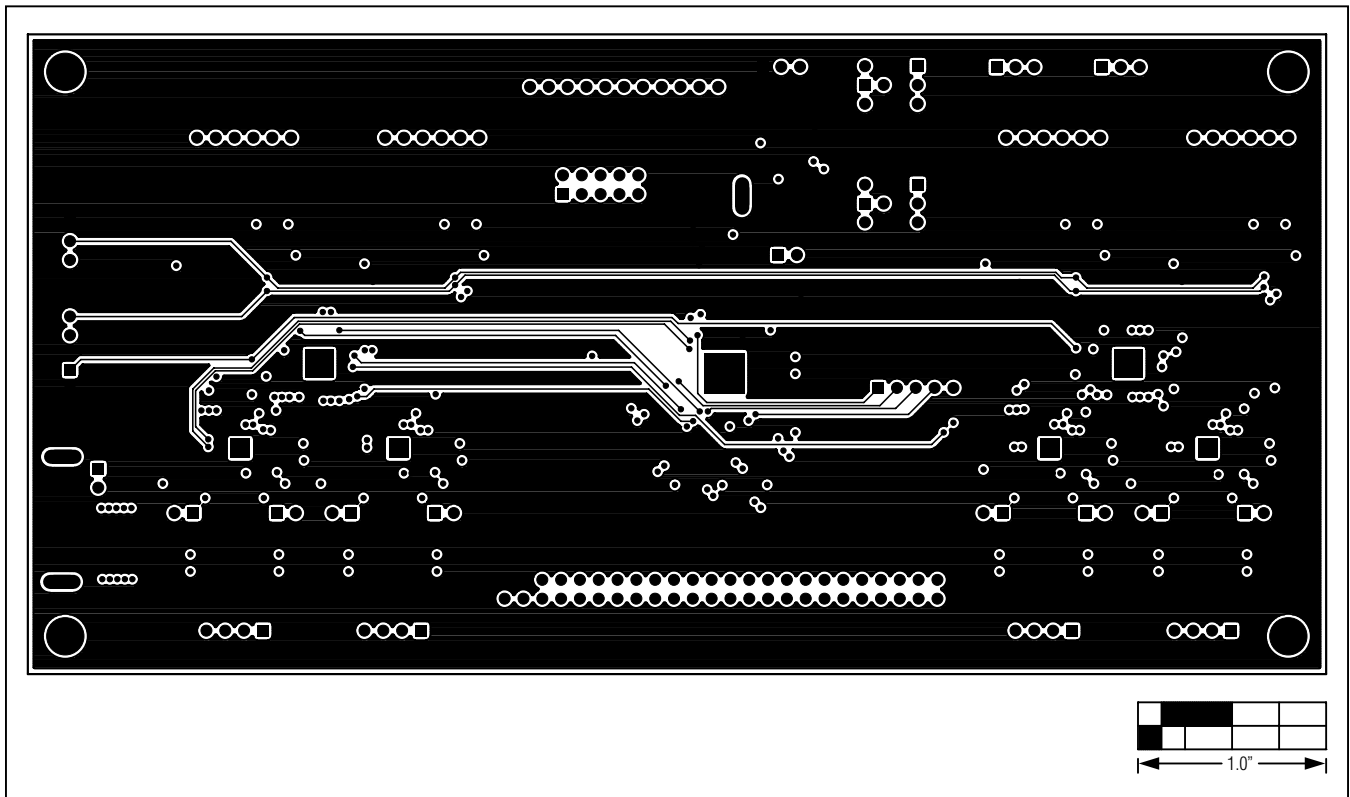

Figure 6. MAX14830 EV Kit PCB Layout—PWR Layer 3

# MAX14830 Evaluation Kit

## Evaluates: MAX14830

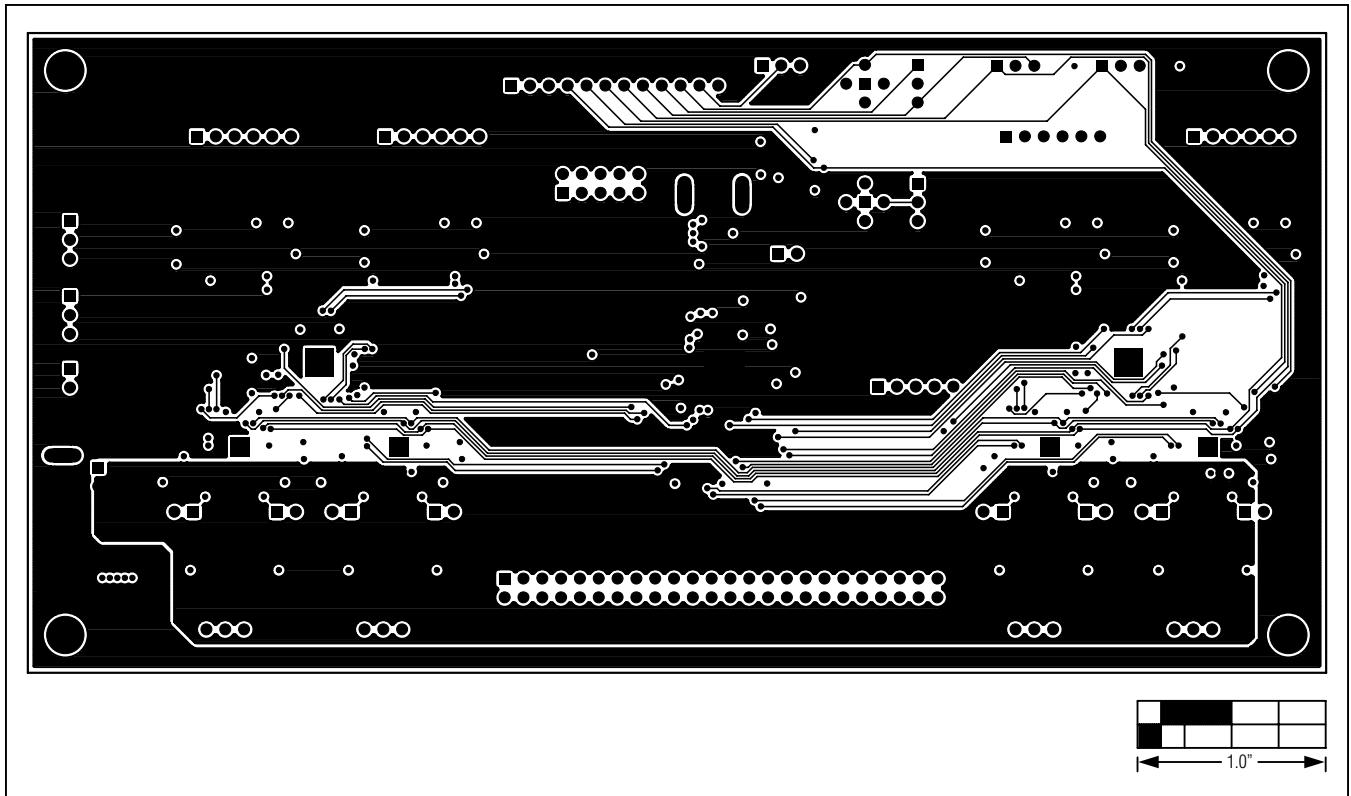

Figure 7. MAX14830 EV Kit PCB Layout—Solder Side

# MAX14830 Evaluation Kit

## Evaluates: MAX14830

### ***Ordering Information***

---

<b>PART</b>	<b>TYPE</b>
MAX14830EVKIT#	EV Kit

*#Denotes RoHS compliant.*