

MAXIM

MAX1553 Evaluation Kit

General Description

The MAX1553 evaluation kit (EV kit) is a fully assembled and tested printed circuit board (PCB) with two complete circuits for evaluating the MAX1553 and MAX1554 white LED step-up converters. The MAX1553 circuit operates from 2.7V to 5.5V and delivers an adjustable 0 to 20mA to drive up to six white LEDs connected in series. The MAX1554 circuit operates from 3.15V to 5.5V and delivers an adjustable 0 to 20mA for driving up to 10 white LEDs in series.

Features

- ◆ Constant-Current Regulation for Even LED Illumination
- ◆ Up to 88% Efficiency Driving Six LEDs
- ◆ Analog or PWM Dimming Control of LED Intensity
- ◆ Small, Low-Profile Components
- ◆ 2.7V to 5.5V Input Range
- ◆ Tiny TDFN 3mm x 3mm IC Package
- ◆ Fully Assembled and Tested

Ordering Information

PART	TEMP RANGE	IC PACKAGE
MAX1553EVKIT+	0°C to +70°C*	8 TDFN (3mm x 3mm)

+ Denotes a lead-free and RoHS-compliant EV Kit.

*This limited temperature range applies to the EV kit PCB only. The MAX1553 IC temperature range is -40°C to +85°C.

Component List MAX1553 Circuit

DESIGNATION	QTY	DESCRIPTION
C1	1	4.7μF ±10%, 6.3V X5R capacitor (0603) Panasonic ECJ1VB0J475K or equivalent
C2, C7	2	0.47μF ±20%, 50V X7R capacitors (1206) TDK C3216X7R1H474M or equivalent
C3, C6	2	0.1μF ±10%, 50V X7R capacitors (0603) TDK C1608X7R1H104K or equivalent
C4, C5	0	Not installed, ceramic capacitors
C8	1	10μF ±20%, 6.3V X5R capacitor (0805) Panasonic ECJ2FB0J106M or Taiyo Yuden JMK212BJ106MG
C9	1	4700pF ±10%, 50V X7R ceramic capacitor (0603) TDK C1608X7R1H472K or equivalent
C10	1	3300pF ±10%, 50V X7R ceramic capacitor (0603) TDK C1608X7R1H332K or equivalent

DESIGNATION	QTY	DESCRIPTION
D1	1	30V Schottky diode (SOD-123) Toshiba CRS02
D2–D17	16	White LEDs Nichia NSCW215T
D18	1	60V, 1A Schottky diode (SMA) Central CMSH1-60M
JU1, JU9	2	2-pin headers
JU2, JU8	2	3-pin headers
JU3	0	Not installed, PCB open
JU4–JU7	0	Not installed, PCB short
L1	1	33μH inductor TOKO #A920CY-330M (D62CB)
L2	1	15μH inductor TOKO #A920CY-150M (D62CB)
R1, R6	2	10.0Ω ±1% resistors (0603)
R2	1	200kΩ ±5% resistor (0603)
R3, R4	2	10kΩ ±5% resistors (0603)
R5	1	330kΩ ±5% resistor (0603)
U1	1	MAX1553ETA+ (8-pin TDFN)
U2	1	MAX1554ETA+ (8-pin TDFN)
—	4	Shunts, 2-position
—	1	PCB: MAX1553 Evaluation Kit+

Evaluates: MAX1553/MAX1554

MAX1553 Evaluation Kit

Component Suppliers

SUPPLIER	PHONE	WEBSITE
Central Semiconductor Corp.	631-435-1110	www.centralsemi.com
Kamaya, Inc.	260-489-1533	www.kamaya.com
Murata Mfg. Co., Ltd.	770-436-1300	www.murata.com
Nichia Corp.	248-352-6575	www.nichia.com
Panasonic Corp.	800-344-2112	www.panasonic.com
Sumida Corp.	847-545-6700	www.sumida.com
Taiyo Yuden	800-438-2496	www.t-yuden.com
TDK Corp.	847-803-6100	www.component.tdk.com
TOKO	847-297-0070	www.toko.com

Note: Indicate that you are using the MAX1553/MAX1554 when contacting these component suppliers.

Quick Start

Recommended Equipment

Power supply capable of providing 2.7V to 5.5V at up to 1A.

Procedure—MAX1553 Circuit

The MAX1553 EV kit is fully assembled and tested. Follow the steps below to verify board operation of the MAX1553 circuit. **Caution: Do not turn on the power supply until all connections are completed.**

- 1) Verify that the pins of JU1 are shorted.
- 2) Verify that the pins of JU2 are shorted across pins 2-3.
- 3) Preset the power supply to between 2.7V and 5.5V.
- 4) Turn off the power supply.
- 5) Connect positive power-supply terminal to the pad on the EV kit labeled IN1.
- 6) Connect power-supply ground terminal to the pad on the EV kit labeled GND1.
- 7) Turn on the power supply and verify that the LEDs are lit.

Procedure—MAX1554 Circuit

Follow the steps below to verify board operation of the MAX1554 circuit. **Caution: Do not turn on the power supply until all connections are completed.**

- 1) Verify that the pins of JU9 are shorted.
- 2) Verify that the pins of JU8 are shorted across pins 2-3.
- 3) Preset the power supply to between 3.15V and 5.5V.
- 4) Turn off the power supply.

- 5) Connect the positive power-supply terminal to the pad on the EV kit labeled IN2.
- 6) Connect the power-supply ground terminal to the pad on the EV kit labeled GND2.
- 7) Turn on the power supply and verify that the LEDs are lit.

Detailed Description

Evaluating the MAX1553

Shutdown

To place the part in low-power shutdown mode, short pins 1-2 of JU2. For normal operation, short pins 2-3 of JU2.

Controlling LED Intensity

LED intensity can be controlled using the BRT1 input. BRT1 can be used either as an analog or digital input. When using BRT1, remove the shunt from JU1. Connect a 0 to 1.72V voltage source to BRT1, where 0V corresponds to the dimmest setting and 1.72V is full brightness. Ground the voltage source to AGND1. A digital PWM signal (100Hz to 10kHz) can also be connected directly to BRT1. In this case, 0% duty cycle corresponds to the dimmest setting and 100% corresponds to the brightest.

Changing the Number of LEDs

The MAX1553 can be used to drive two to six LEDs, and the MAX1553 EV kit comes configured for driving six LEDs. To evaluate the MAX1553 driving fewer than six LEDs, short the pads of the unused LEDs. For convenience, JU3 can be used to short LEDs D2 and D3 for four LED operation.

Connecting External LEDs to the EV Kit

Surface-mount white LEDs come installed on the EV kit, but it can also be connected to an external LED string. To connect external LEDs, cut the trace shorting JU4. Then, connect the anode of the series string to OUT1+ and connect the cathode of the series string to OUT1-.

Using Separate Supplies to Power the IC and Boost

In some applications, the MAX1553 IC and the boost inductor are powered from different supplies. For example, the IC can be powered with a 3.3V logic supply and the boost inductor can be connected to a battery. This is useful if the battery voltage is lower than the operating range of the MAX1553.

To use different supplies for the IC and boost, cut the trace shorting JU5 on the solder side of the EV kit, then install a 0.1 μ F ceramic capacitor in C4. Connect a 2.7V to 5.5V power supply to VCC1 to power the IC. Connect another power supply to IN1 (the voltage range is not limited to the IC supply range). Ground both power supplies at GND1.

MAX1553 Evaluation Kit

Evaluates: MAX1553/MAX1554

Evaluating the MAX1554

Shutdown

To place the part in low-power shutdown mode, short pins 1-2 of JU8. For normal operation, short pins 2-3 of JU8.

Controlling LED Intensity

LED intensity can be controlled using the BRT2 input. BRT2 can be used either as an analog or digital input. When using BRT2, remove the shunt from JU9. Connect a 0 to 1.72V voltage source to BRT2, where 0V corresponds to the dimmest setting and 1.72V is full brightness. Ground the voltage source to AGND2. A digital PWM signal (100Hz to 10kHz) can also be connected directly to BRT2. In this case, 0% duty cycle corresponds to the dimmest setting and 100% corresponds to the brightest.

Changing the Number of LEDs

The MAX1554 can be used to drive up to 10 LEDs. If fewer than 10 LEDs are used, short the pads of the unused LEDs.

Connecting External LEDs to the EV Kit

To connect external LEDs, cut the trace shorting JU7, then connect the anode of the series string to OUT2+ and connect the cathode of the series string to OUT2-.

Using Separate Supplies to Power the IC and Boost

To use different supplies for the IC and boost, cut the trace shorting JU6 on the solder side of the EV kit; then, install a 0.1µF ceramic capacitor in C5. Connect a 2.7V to 5.5V power supply to VCC2 to power the IC. Connect another power supply to IN2 (voltage range is not limited to the IC supply range). Ground both power supplies at GND2.

Table 1. MAX1553 Circuit Jumper Functions

JUMPER	FUNCTION	DEFAULT SETTING
JU1	Connects V _{CC} to BRT when no separate BRT control signal is used.	Shorted.
JU2	EN Control. Jumper pin 1 to pin 2 for shutdown. Jumper pin 2 to pin 3 for enable.	Jumper 2 to 3. Enabled.
JU3	Bypasses two of the six LEDs for four LED testing.	Open. Six LED operation.
JU4	Connects on-board LEDs. Cut the PCB trace to power other LEDs.	Shorted for on-board LEDs.
JU5	The PCB trace connects V _{CC} to IN for single-supply operation. Cut the trace to separately power V _{CC} and IN.	Shorted for single-supply operation.

Table 2. MAX1554 Circuit Jumper Functions

JUMPER	FUNCTION	DEFAULT SETTING
JU6	PCB trace connects V _{CC} to IN for single-supply operation. Cut the trace to separately power V _{CC} and IN.	Shorted for single-supply operation.
JU7	Connects on-board LEDs. Cut the PCB trace to power other LEDs.	Shorted for on-board LEDs.
JU8	EN Control. Jumper pin 1 to pin 2 for shutdown. Jumper pin 2 to pin 3 for enable.	Jumper 2 to 3. Enabled.
JU9	Connects V _{CC} to BRT when no separate BRT control signal is used.	Shorted.

MAX1553 Evaluation Kit

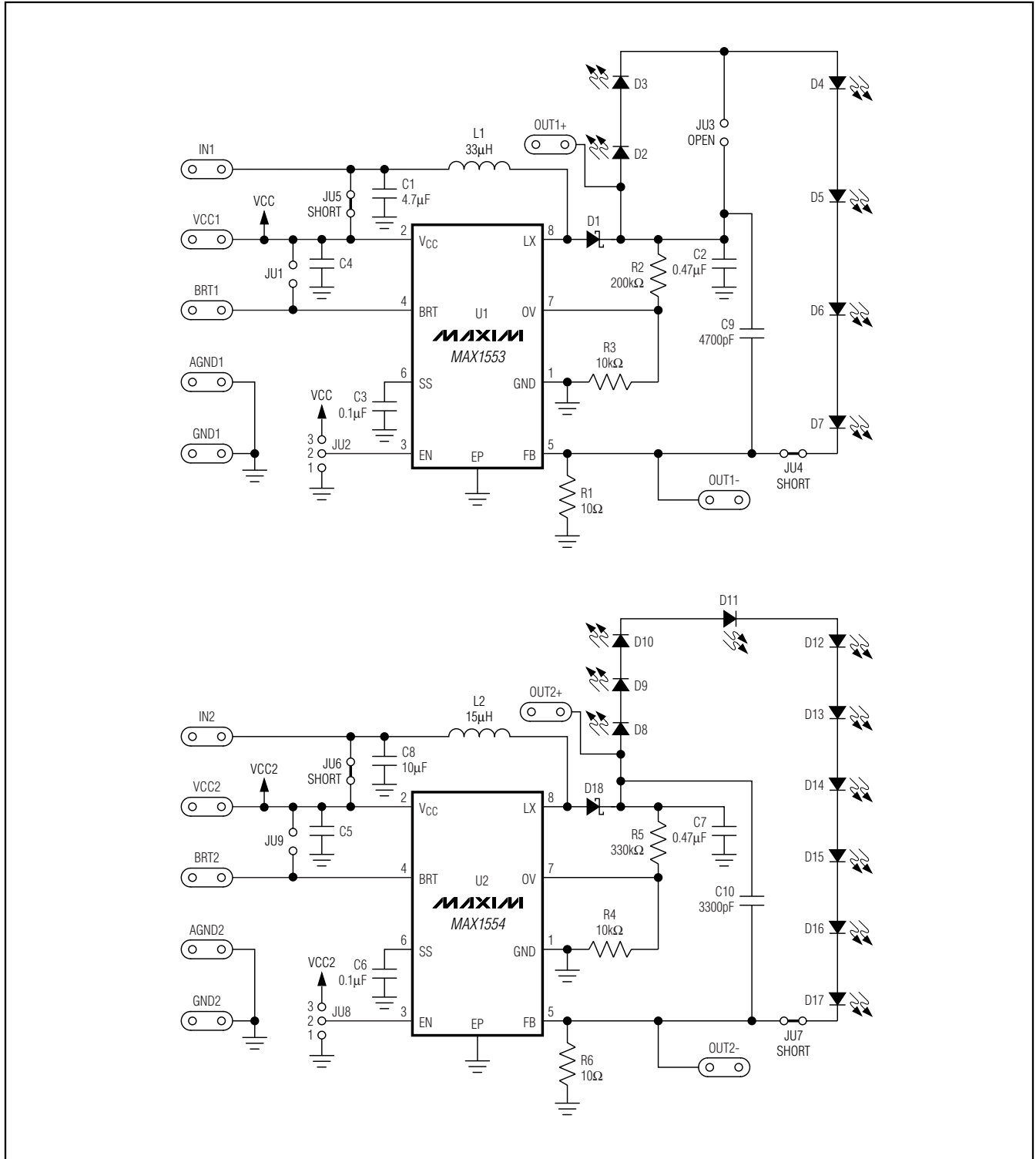

Figure 1. MAX1553 EV Kit Schematic

MAX1553 Evaluation Kit

Evaluates: MAX1553/MAX1554

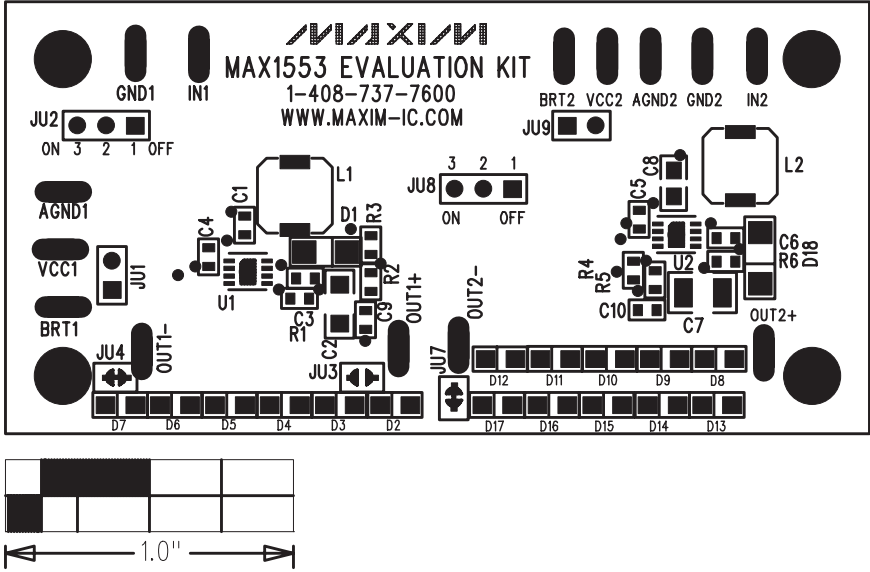

Figure 2. MAX1553 EV Kit Component Placement—Component Side

MAX1553 Evaluation Kit

Evaluates: MAX1553/MAX1554

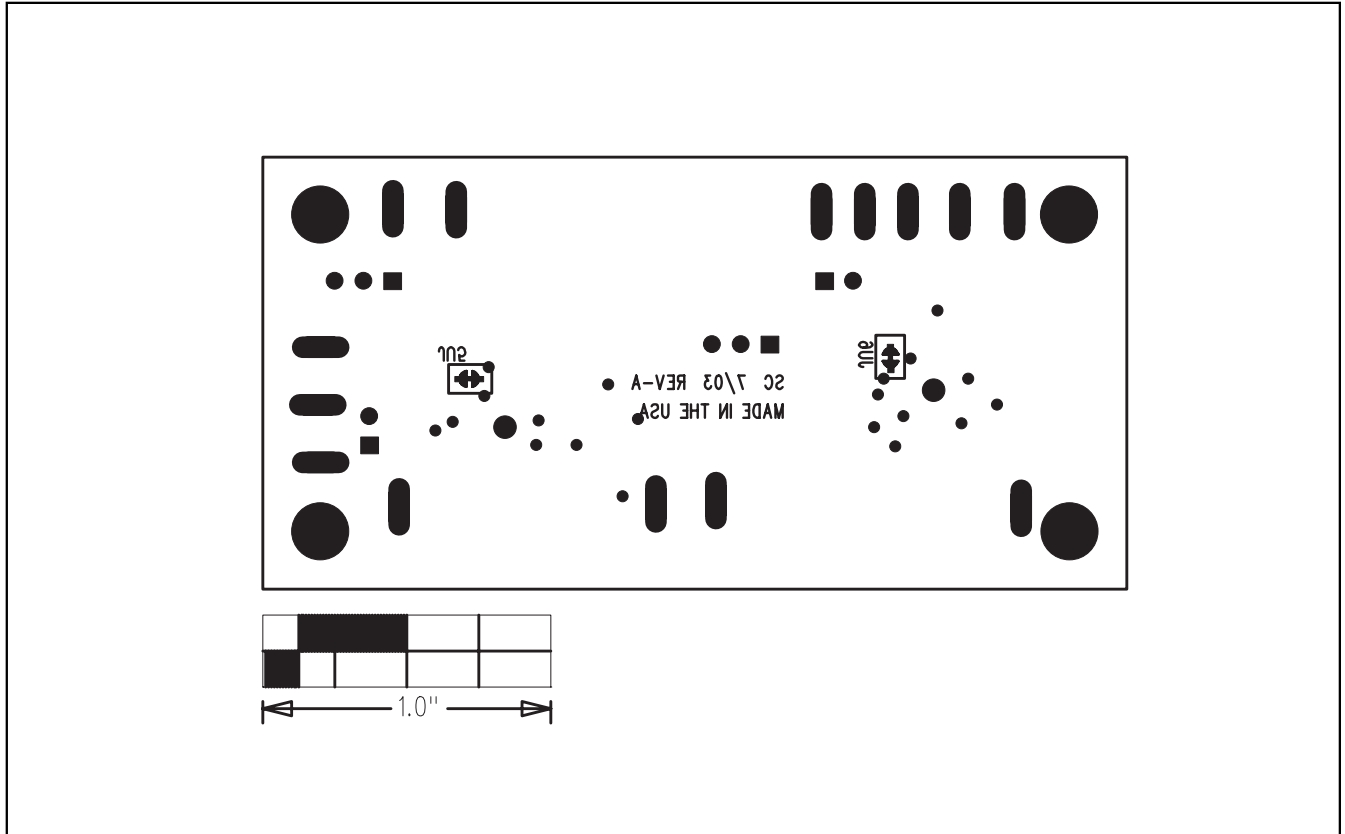

Figure 3. MAX1553 EV Kit Component Placement—Solder Side

MAX1553 Evaluation Kit

Evaluates: MAX1553/MAX1554

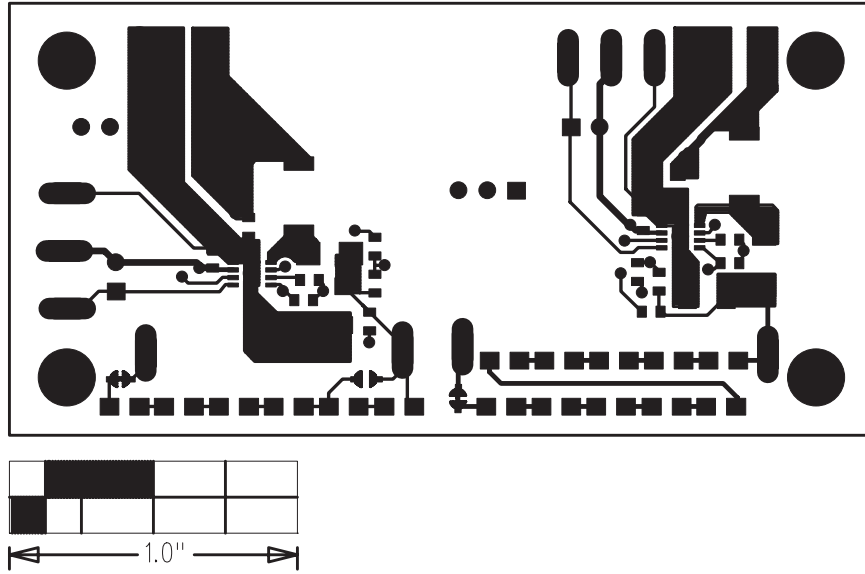

Figure 4. MAX1553 EV Kit PCB Layout—Component Side