



MAX16029 Evaluation Kit

General Description

The MAX16029 evaluation kit (EV kit) is designed to evaluate the MAX16029 quad-voltage, capacitor-adjustable, sequencing/supervisory circuit. The kit includes a fully assembled and tested PCB that allows easy access to all major functions of the part, including the inputs, timeout-delay capacitors, and outputs.

The MAX16029 EV kit comes with the MAX16029 installed, but can also be used to evaluate the MAX16030 and MAX16043.

Features

- ◆ Easy Configuration with Jumpers
- ◆ Input Connections Include Pads for Resistive Dividers
- ◆ Master Reset Pushbutton

Ordering Information

PART	TEMP RANGE	IC PACKAGE
MAX16029EVKIT+	0°C to +70°C*	24 TQFN-EP†

+Denotes a lead-free and RoHS-compliant EV kit.

*This limited temperature range is for the EV kit PCB only. The MAX16029 IC temperature range is -40°C to +125°C.

†EP = Exposed paddle.

Component List

DESIGNATION	QTY	DESCRIPTION
C1	1	0.1μF ±10%, 50V X7R ceramic capacitor (0805) TDK C2012X7R1H104K or Taiyo Yuden UMK212BJ104KG
C2–C5	0	Not installed, capacitors (0603)
C6	1	0.022μF ±10%, 25V X7R ceramic capacitor (0603) TDK C1608X7R1H223K Taiyo Yuden TMK107BJ223KA

DESIGNATION	QTY	DESCRIPTION
J1, J5–J8, J13	6	2-pin headers
J2, J3, J4, J9–J12	7	3-pin headers
R1–R8	0	Not installed, resistors (0805)
R9–R13	5	100kΩ ±1% resistors (0805)
S1	1	Momentary tact switch, SPST
U1	1	MAX16029TG+
—	12	Shunts, 2 position (see Tables 1 and 2)
—	1	MAX16029 EV kit PCB

Component Suppliers

SUPPLIER	PHONE	FAX	WEBSITE
TDK Corp.	847-390-4373	847-390-4428	www.component.tdk.com
Taiyo Yuden	847-925-0888	847-925-0899	www.t-yuden.com

Note: Indicate that you are using the MAX16029 EV kit when contacting these component suppliers.

MAX16029 Evaluation Kit

Quick Start

Required Equipment

- Five power supplies: 5V, 3.3V, 2.5V, 1.8V, and 1.5V
- An oscilloscope

Procedure

The MAX16029 EV kit is fully assembled and tested. Follow the steps below to verify board operation.

Caution: Do not turn on the power supplies until all connections are completed.

- 1) Connect a 5V power supply to VCC and GND, connect 3.3V to IN1, connect 2.5V to IN2, connect 1.8V to IN3, and connect 1.5V to IN4.
- 2) Ensure that jumper J1 is open and jumpers J2, J3, and J4 are in the 2-3 position. Jumpers J5–J8 and J13 must be closed and J9–J12 must be in the 1-2 position.
- 3) Connect an oscilloscope to OUT1 and $\overline{\text{RESET}}$.
- 4) Turn on the 5V supply, and observe that OUT1 and $\overline{\text{RESET}}$ are low.
- 5) Turn on the 3.3V supply, and observe that although OUT1 is high, $\overline{\text{RESET}}$ is still low.
- 6) Turn on the remaining supplies, observing that after the last supply voltage exceeds its threshold, $\overline{\text{RESET}}$ goes high.
- 7) Press the $\overline{\text{MR}}$ button and observe $\overline{\text{RESET}}$.

Detailed Description

The MAX16029 and the MAX16030/MAX16043 (that can also be evaluated on this EV kit) operate from 2.2V to 28V. They monitor up to four voltages and provide individual outputs (OUT1–OUT4) that indicate if the corresponding input is above or below its threshold. Additionally, each channel has a specific capacitor-set timeout delay.

Additional features include a $\overline{\text{RESET}}$ output that goes high once all outputs are high and has its own capacitor-set delay. A $\overline{\text{MR}}$ input (controlled by the pushbutton) allows an operator to initiate a device reset, or is controlled by external logic.

Monitoring Inputs

Each channel monitors a voltage and controls the corresponding output according to whether it is above or below a specific threshold voltage. The threshold is either adjustable or fixed, depending on the settings of J3 and J4 (see Table 2). The voltage tolerance of 10% or 5% is set using J2. To support adjustable threshold

inputs, the EV kit provides space for resistor-dividers (R1–R8). To calculate the resistor values that obtain a specific threshold, use the following formula:

$$V_{\text{INTH}} = V_{\text{TH}} \times \left(1 + \frac{R_1}{R_2} \right)$$

where V_{TH} is the adjustable threshold voltage.

Outputs

If a voltage present on an input goes above that input's threshold, the corresponding output asserts after a capacitor-set (C2–C5) time delay. Set the capacitor value according to the following equation:

$$t_{\text{DELAY}} = \left(4 \times 10^6 \frac{\text{V}}{\text{A}} \right) \times C_{\text{CDLY}} + 35 \times 10^{-6}$$

where t_{DELAY} is in seconds and C_{CDLY} is in farads. The MAX16030 provides push-pull outputs, while the MAX16029 and MAX16043 provide open-drain outputs. The EV kit pullup resistors (R10–R13) may be enabled using J5–J8 if the MAX16029 or the MAX16043 is the part being evaluated.

$\overline{\text{RESET}}$ Output

The $\overline{\text{RESET}}$ output is the result of an AND operation on the four outputs. Once all four outputs go high, $\overline{\text{RESET}}$ deasserts high after a capacitor-set or fixed timeout delay set by C6 or J1. If J1 is closed, the timeout delay is 200ms. If J1 is open, the timeout delay is set by capacitor C6 to 22ms. If desired, the capacitor can be replaced. The value of the timeout is calculated using the following formula:

$$t_{\text{RP}} = \left(1 \times 10^6 \frac{\text{V}}{\text{A}} \right) \times C_{\text{CRESET}} + 35 \times 10^{-6}$$

where t_{RP} is in seconds and C_{CRESET} is in farads. $\overline{\text{RESET}}$ asserts low if $\overline{\text{MR}}$ is pulled low. The EV kit provides pushbutton S1 that pulls $\overline{\text{MR}}$ low to evaluate this feature.

The MAX16029 uses an open-drain $\overline{\text{RESET}}$ output, so jumper J13 must be closed to connect pullup resistor R9. If the EV kit is used to evaluate the MAX16030 or MAX16043, open jumper J13, as these parts both have a push-pull $\overline{\text{RESET}}$ output.

MAX16029 Evaluation Kit

ENABLE Inputs

The ENABLE inputs allow individual logic-level control over each monitoring channel. Jumpers J9–J12 on the EV kit allow control over each, with position 1-2 representing a logic-high and position 2-3 a logic-low.

Jumper Function Tables

Table 1. J1, J2, and J5–J12 Jumper Function

JUMPER	POSITION	FUNCTION
J1	Open	Capacitor-set reset timeout (22ms)
	Closed*	Internally set reset timeout (200ms)
J2	1-2	10% threshold tolerance
	2-3*	5% threshold tolerance
J5–J8	Open*	OUT_ pullups disabled
	Closed	OUT_ pullups enabled
J9–J12	1-2*	OUT_ enabled
	2-3	OUT_ disabled
J13	Open	RESET pullup disabled
	Closed*	RESET pullup enabled

*Default position.

Table 2. J3 and J4 Jumper Function—Input Threshold Select

J3	J4	IN1	IN2	IN3	IN4
2-3*	2-3*	3.3V	2.5V	1.8V	1.5V
2-3	1-2	3.3V	1.8V	ADJ	ADJ
2-3	Open	3.3V	1.5V	ADJ	ADJ
1-2	2-3	3.3V	1.2V	1.8V	2.5V
1-2	1-2	2.5V	1.8V	ADJ	ADJ
1-2	Open	3.3V	ADJ	2.5V	ADJ
Open	2-3	3.3V	ADJ	ADJ	ADJ
Open	1-2	2.5V	ADJ	ADJ	ADJ
Open	Open	ADJ	ADJ	ADJ	ADJ

*Default position.

Evaluates: MAX16029/MAX16030/MAX16043

MAX16029 Evaluation Kit

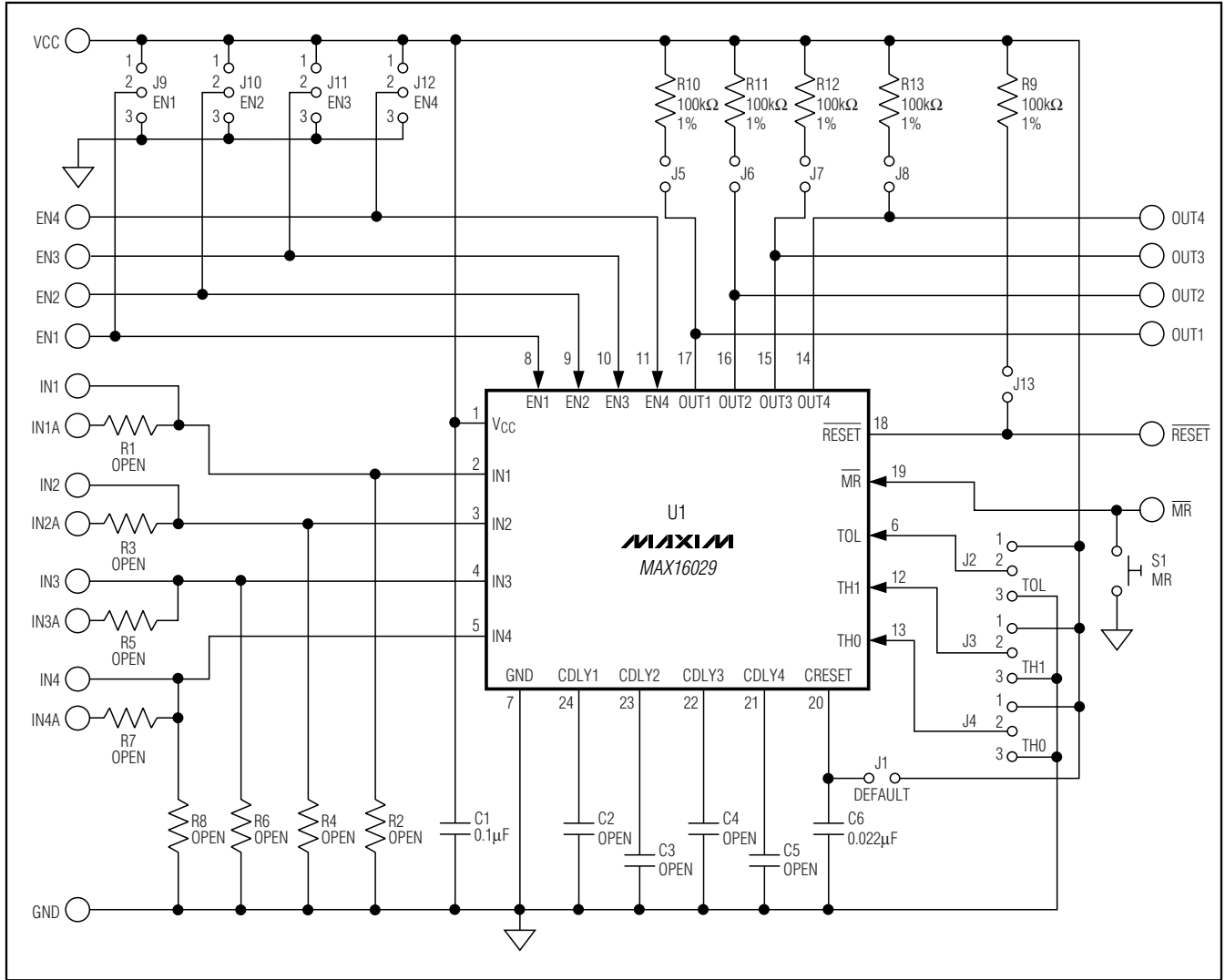

Figure 1. MAX16029EV Kit Schematic

MAX16029 Evaluation Kit

Evaluates: MAX16029/MAX16030/MAX16043

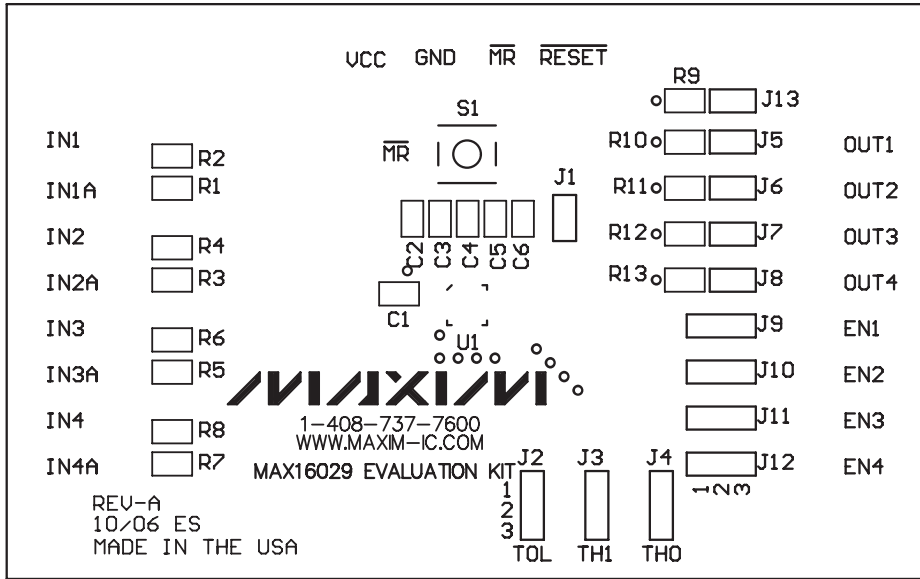

Figure 2. MAX16029EV Kit Component Placement Guide—Components Side

MAX16029 Evaluation Kit

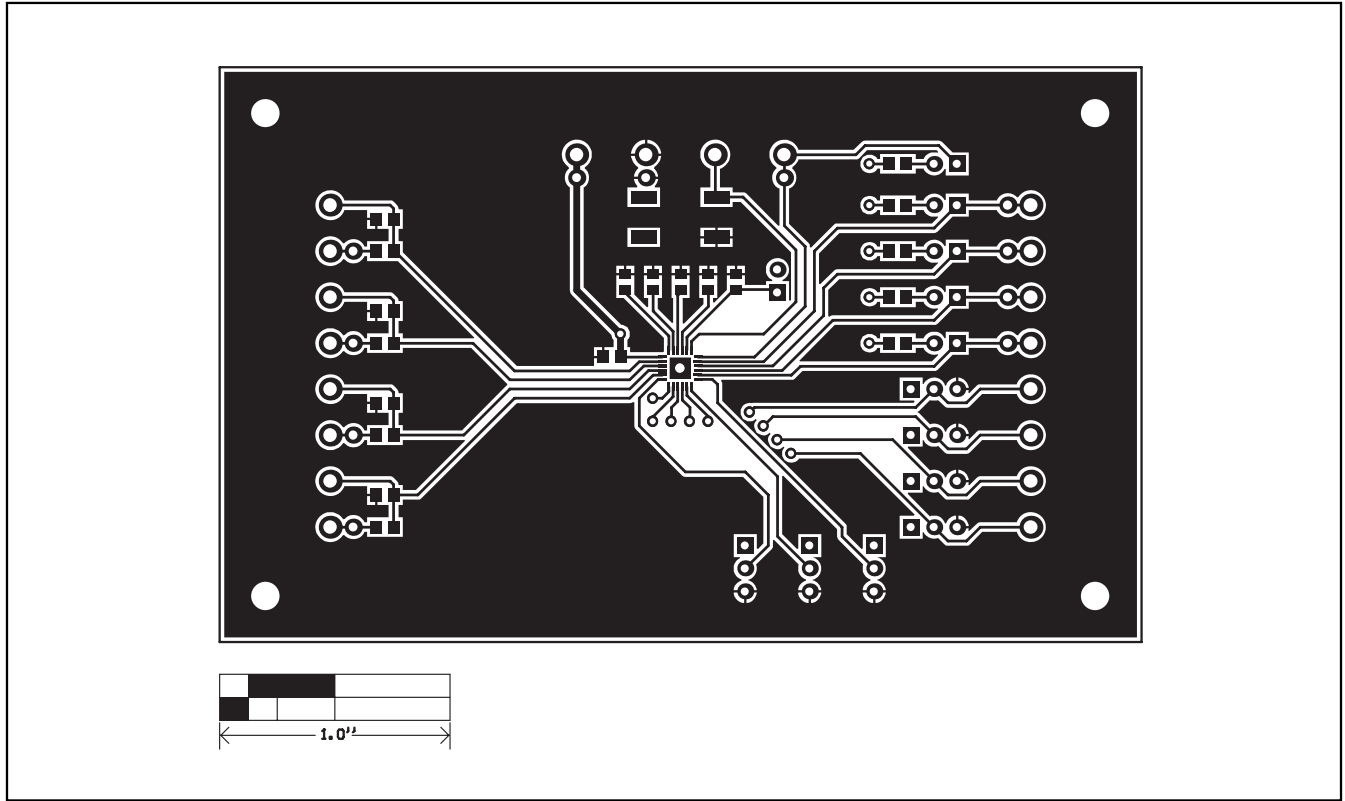

Figure 3. MAX16029EV Kit PCB Layout—Component Side