



MAX1640 Evaluation Kit

Evaluates: MAX1640/MAX1641

General Description

The MAX1640 evaluation kit (EV kit) is an adjustable switch-mode current source that operates from a 5.5V to 26V input. It is intended for microprocessor-controlled battery chargers. The charging current, maximum voltage, and pulse-trickle charge are programmed with external resistors. The EV kit is shipped configured for a maximum charge voltage (6 cells). It is configured as a step-down pulse-width modulator (PWM) with synchronous rectification, allowing fast-charge currents up to 1.5A with greater than 90% efficiency. The MAX1640 uses high-side current sense; this allows the load to connect directly to ground, eliminating ground potential errors. The MAX1641 uses low-side current sense.

The MAX1640 EV kit is a fully assembled and tested surface-mount printed circuit board. It can also be used to evaluate the MAX1641.

Features

- ◆ 5.5V to 26V Input Voltage Range
- ◆ Tight Current-Regulation Accuracy: 2% (MAX1641); 5% (MAX1640)
- ◆ Up to 1.5A Fast-Charge Current
- ◆ Up to 500kHz PWM Operation
- ◆ Pulse-Trickle Charge Current
- ◆ 100% Maximum Duty Cycle (low dropout)
- ◆ Synchronous Rectifier
- ◆ Surface-Mount Components
- ◆ Fully Assembled and Tested

Ordering Information

PART	TEMP. RANGE	BOARD TYPE
MAX1640EVKIT	0°C to +70°C	Surface Mount

Note: To evaluate the MAX1641, request a MAX1641EEE free sample with the MAX1640 EV kit.

Component List

DESIGNATION	QTY	DESCRIPTION
C1, C8	2	47µF, 35V electrolytic capacitors Sanyo 35CV47GX
C2	1	0.33µF ceramic capacitor
C3, C6, C7	3	0.1µF ceramic capacitors
C4	1	0.01µF ceramic capacitor
C5	1	4.7µF, 16V tantalum capacitor Sprague 595D475X0016A2T
C9	0	Open
D1 (optional)	0	1A, 30V Schottky diode Motorola MBRS130LT3 or Nihon EC10QS03
J1, J2	2	2-pin term connectors
J3	1	6-pin header
L1	1	47µH power inductor Sumida CDRH125-470, Coilcraft DO3316P-473, or Coiltronics UP2-470

DESIGNATION	QTY	DESCRIPTION
R1, R2	2	0.100Ω, 1% 1/2W resistors Dale WSL-2010-R100-F or IRC LR2010-01-R100-F
R3, R5	2	68kΩ, 5% resistors
R4, R7, R10	3	200kΩ, 5% resistors
R6, R8, R9	3	1MΩ, 5% resistors
R11	0	Open
SW1	1	4-position dip switch
U1	1	MAX1640EEE (QSOP-16)
U2	1	Dual P- and N-channel MOSFET (SO-8) International Rectifier IRF7309 or Siliconix Si4539DY
None	1	MAX1640/MAX1641 data sheet
None	1	MAX1640/MAX1641 PC board
None	1	Shunt



MAX1640 Evaluation Kit

Component Suppliers

SUPPLIER	PHONE	FAX
AVX	(803) 946-0690	(803) 626-3123
Coilcraft	(847) 639-6400	(847) 639-1469
Coiltronics	(561) 241-7876	(561) 241-9339
Dale-Vishay	(402) 564-3131	(402) 563-6418
International Rectifier	(310) 322-3331	(310) 322-3332
IRC	(512) 992-7900	(512) 992-3377
Motorola	(602) 303-5454	(602) 994-6430
Nihon	(805) 867-2555	(805) 867-2698
Sanyo	(619) 661-6835	(619) 661-1055
Siliconix	(408) 988-8000	(408) 970-3950
Sprague	(603) 224-1961	(603) 224-1430
Sumida	(847) 956-0666	(847) 956-0702
Vishay/Vitramon	(203) 268-6261	(203) 452-5670

Note: Please indicate that you are using the MAX1640 when contacting these component suppliers.

Quick Start

The MAX1640 EV kit is fully assembled and tested. Follow these steps to verify board operation. **Do not turn on the power supply until all connections are completed.**

- 1) Set the number of cells in the battery pack being charged by placing the shunt across J3, pins 1 and 6. The MAX1640 EV kit is shipped configured for six cells and 1.5A of charge current.
- 2) Connect the input power supply (26V max) to the 2-pin power connector J1. The input supply must be 1V greater than the maximum battery-charging voltage and capable of providing the charge current.
- 3) Connect the battery terminals to the 2-pin power connector J2. Observe the polarity markings.
- 4) Turn on the power supply to the board, and use a voltmeter to confirm the voltage across the battery.

Detailed Description

The MAX1640 EV kit is a switch-mode current source that uses a hysteretic current-mode, step-down, pulse-width-modulated (PWM) topology with constant off time. The switching mechanism is controlled by internal comparators that monitor the current through a sense resistor (R1 or R2) and the voltage at TERM. When the inductor current reaches the current limit, the P-channel FET turns off, and the N-channel FET synchronous rectifier turns on. Inductor energy is delivered to the load

as the current ramps down at a rate controlled by a resistor from TOFF to ground (R3) and the inductor value. When the off time expires, the P-channel FET is turned back on, and the N-channel FET is turned off.

Selecting the Output Current Levels

Switch SW1 controls the two digital inputs, D0 and D1, that select between four possible current levels (see Table 1).

In pulse-trickle mode, the switch is on for 12.5% of the period set by R3, resulting in a lower current for trickle charging. Refer to the *Programming the Output Currents* section in the MAX1640/MAX1641 data sheet for instructions on selecting the current levels.

Selecting the Number of Cells

Selection of the maximum charge voltage (number of cells) in the MAX1640 EV kit is made via a voltage divider selected by J3. Place the shunt across the J3 pins to select the desired number of cells as indicated by the silkscreen on the board. Refer to the section *Setting the Maximum Output Voltage Level* in the MAX1640/MAX1641 data sheet for instructions on selecting the resistor-divider values. The EV kit is shipped configured for a maximum charge voltage of 12V (six cells). Refer to Table 2 for the selectable J3 options.

Table 1. Charge-Current Levels (SW1)

D1	D0	OUTPUT CURRENT
0	0	0A, current off
0	1	0.375A, top-off charge
1	0	0.5A at 12.5% duty cycle, trickle charge
1	1	1.5A, fast charge

Table 2. Jumper J3 Functions

SHUNT LOCATION	NUMBER OF CELLS
1 and 6	6 (12V)
2 and 5	2 (4V)
3 and 4	(User-defined R11)

MAX1640 Evaluation Kit

Evaluating the MAX1641

The MAX1640 EV kit can also be used to evaluate the MAX1641. Replace the MAX1640 with the MAX1641, cut jumpers JU2 and JU4, and install jumpers JU1 and JU3. Table 3 summarizes the JU1–JU4 functions.

Table 3. Jumper JU1–JU4 Functions

JUMPER	MAX1641 LOW-SIDE SENSE	MAX1640 HIGH-SIDE SENSE
JU1	Short	Open
JU2	Open	Short
JU3	Short	Open
JU4	Open	Short

Evaluates: MAX1640/MAX1641

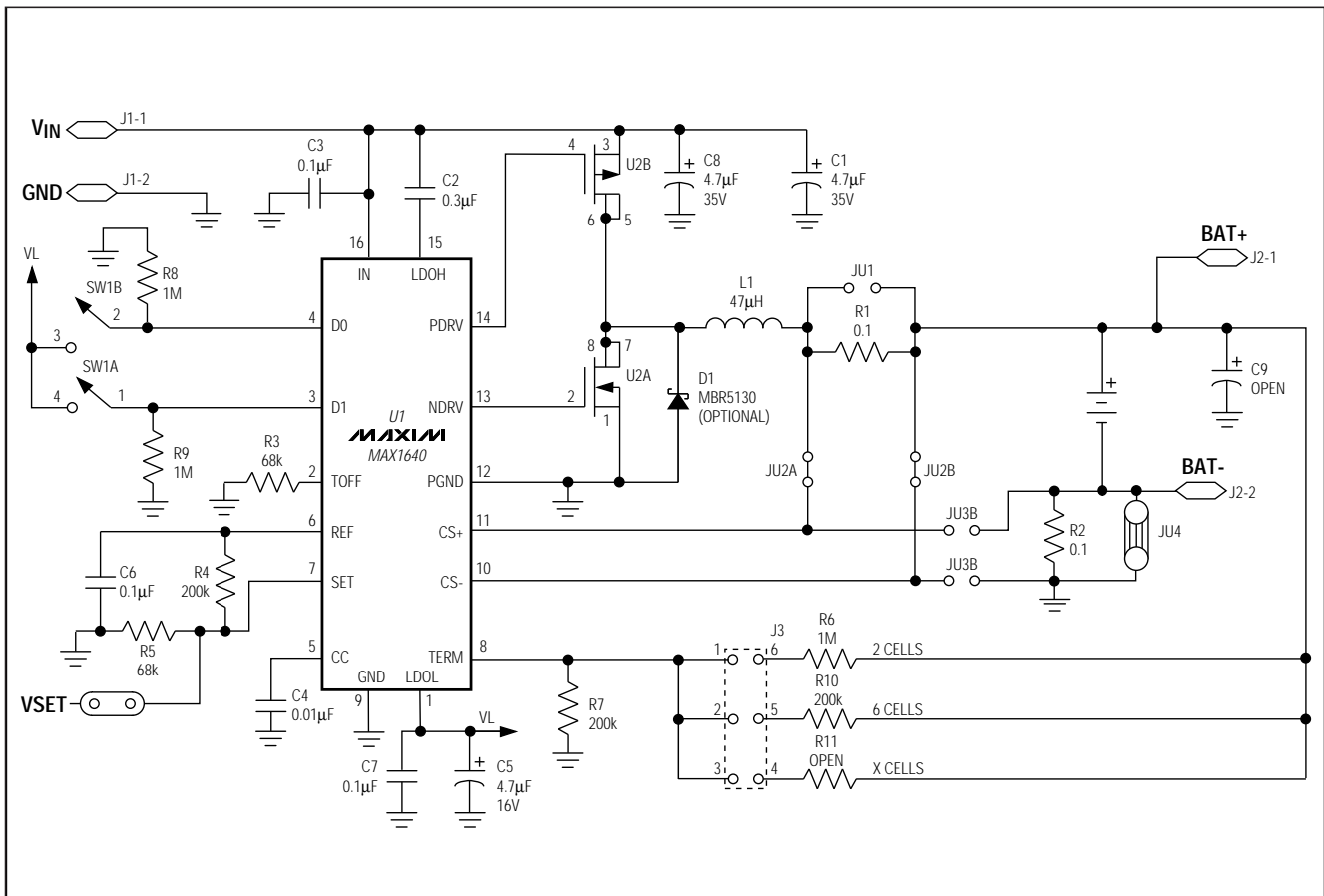

Figure 1. MAX1640 EV Kit Schematic