

General Description

The MAX17841B evaluation kit (EV kit) demonstrates the capabilities of the MAX17841B automotive SPI communication interface (ASCI) IC, in conjunction with a Maxim high-voltage data-acquisition system (MHVDAS). The MAX17841B allows the connection of multiple high-voltage data-acquisition IC EV kits, supporting up to a 32-device (max) daisy-chain configuration.

Benefits and Features

- Supports Maxim's Battery-Management UART Protocol
- SPI Interface Up to 4MHz
- Supports ASIL Requirements
- Windows XP®, Windows Vista®, Windows® 7-, and Windows 10-Compatible Software
- Proven PCB Layout
- Fully Assembled and Tested

Ordering Information appears at end of data sheet.

Quick Start

The following procedure describes the setup and testing of a two-module-distributed daisy-chained system using any of the Maxim high-voltage data-acquisition system (MHVDAS). The user can choose to configure as many EV kit modules as needed, based on their system and testing requirements.

Required Equipment

- MAX17841B EV kit (includes the MINIQUSB)
- MHVDAS EV kit (two (min))
- Maxim command module (MINIQUSB)
 - MINIQUSB board
 - MINIQUSB-XHV board (do not use this board)
- DC power supplies (refer to the respective MHVDAS IC data sheet for recommended operating ranges)
- User-supplied Windows XP-, Windows Vista-, Windows 10-, or Windows 7-compatible PC with a spare USB port

Note: In the following sections, software-related items are identified by bolding. Text in **bold** refers to items directly from the EV kit software. Text in **bold and underlined** refers to items from the Windows operating system.

Windows, Windows Vista, and Windows XP are registered trademarks and registered service marks of Microsoft Corporation.

Procedure

The MAX17841B EV kit is fully assembled and tested. Follow the steps below to verify board operation. **Caution: Do not enable the power supplies until all connections are completed.**

- 1) Install the EV kit software on your PC by running the installer package of the MHVDAS.
- 2) Connect the MINIQUSB module to the J3 and J4 headers on the MAX17841B EV kit.
- 3) Connect the USB cable from the PC to the MINIQUSB board. A **Building Driver Database** window pops up in addition to a **New Hardware Found** message if this is the first time the EV kit board is connected to the PC. If a window is not seen like the one described above after 30s, remove the USB cable from the MINIQUSB and reconnect it. Administrator privileges are required to install the USB device driver on Windows XP, Windows Vista, Windows 10, and Windows 7.
- 4) Appropriate FTDI drivers may need to be downloaded and installed from the website at <http://www.ftdichip.com/Drivers/D2XX.html>.
- 5) Ensure that all jumper shunts and switches are configured, as shown in [Table 1](#).
- 6) Configure the DC power supplies for the MHVDAS for 18V and disable their outputs.
- 7) Connect the grounds of each power supply together, and then connect this common ground to AGND on the MAX17841B EV kit.
- 8) Connect the first 18V supply between the PACK+ and PACK- PCB pads on the MHVDASEV kit.
- 9) Connect the second 18V supply between the PACK+ and PACK- PCB pads on the second MHVDAS EV kit (if applicable).
- 10) Connect the 2-wire blue crossover cables as described below:
 - Connect P1 on the MAX17841B EV kit to the appropriate port of the MHVDAS EV kit.
 - Connect P2 on the MAX17841B EV kit to the appropriate port of the MHVDAS EV kit.
 - Any daisy-chain MHVDAS ICs should be configured accordingly (refer to the respective MHVDAS EV kit data sheet for details).

- 11) Enable the DC power supply.
- 12) Start the appropriate MHVDAS EV kit software. The MHVDAS EV kit software automatically establishes a connection with the MAX17841B EV kit. Typically, a status bar at the bottom of the GUI will display **MAX17841 Detected**, so proceed to the next step.
- 13) The EV kit is now ready for further evaluation. Refer to the respective MHVDAS EV kit data sheet and GUI for details on how to proceed with evaluation.

Description of Software

The MAX17841B EV kit is evaluated in conjunction with the MHVDAS graphical user interface (GUI) evaluation software. The GUI provides a friendly environment for reading and writing to all device registers, as well as executing several device commands and evaluating the functionality of the IC.

The GUI provides shutdown/enabling of the MAX17841B device, waking up the device, as well as the communication with the MHVDAS IC.

Table 1. MAX17841B EV Kit Default Jumper Settings

JUMPER	SHUNT POSITION
JU1–JU4, JU6, JU7	On one pin only
JU5	1-2

Ordering Information

PART	TYPE
MAX17841EVMINIQU#	EV Kit

#Denotes RoHS compliant.

MAX17841B EV Kit Bill of Materials

REFERENCE DESIGNATOR	QTY.	DESCRIPTION	MFG. PART NO.	RoHS AND LEAD-FREE COMPLIANT?
AGND, DCIN, GNDL (X2)	4	20G tinned copper Bus wire formed into "U" shaped loops (0.25" off the PCB)		
ALRMOV, ALRMUV	2	LED, Red (0603)	LITE-ON LTST-C190EKT	
/CSI, DIN, DOUT, SCLK, VAA	5	Miniature Test Points, Red	KEYSTONE 5000	
C1, C7	2	1µF ±10%, 16V X7R ceramic capacitors, automotive grade (0603)	Murata GCM188R71C105KA64D	Yes
C2, C3	2	15pF ±5%, 100V C0G ceramic capacitors, automotive grade (0603)	Murata GCM1885C2A150J	Yes
C6	1	0.01µF ±10%, 25V X7R ceramic capacitors (0603)	Murata GRM188R71E103K	Yes
C8	1	0.1µF ±10%, 50V X7R ceramic capacitor (0603)	Murata GRM188R71H104K	
C10-13	4	2200pF ±10%, 630V U2J ceramic capacitors, auto grade (1206)	Murata GCM31A7U2J222JX01D	
C10-13	4	2200pF ±10%, 630V X7R ceramic capacitors (1206)	TDK C3216X7R2J222K	
C24, C25	2	1nF ±10%, 630V X7R ceramic capacitors, auto grade (1206)	Murata GCJ31BR72J102KXJ1L	
D1	1	ESD protection diodes (SOT-23)	NXP Semiconductors PESD1CAN	
D2-D7	6	Unidirectional ESD protection diodes (SOD323)	NXP Semiconductors PESD5V0U1UA	
D9	1	Schottky diode (SOT-23)	Fairchild Semiconductor BAT54	
GPI07, GPIO8, RX_N (x2), TX_N (x2)	6	Multipurpose Test Points, Black	KEYSTONE 5011	
J1, J2, J4	3	8 pin receptacles (0.1in centers)	Samtec SSW-108-01-T-S	
J3	1	2x8 pin straight double-row header, 0.1in centers	Sullins PEC36DAAN	
J5, J6	2	6-pin female receptacle, 0.1in centers	Samtec SSW-106-01-T-S	
J7	1	6 pin right angle header, 0.1in centers	SAMTEC TSW-106-08-S-S-RA	
JU1, JU2, JU3, JU4,	4	2 pin headers (0.1in centers)	Sullins PEC36SAAN	Yes
JU5	1	3 pin headers (0.1in centers)	Sullins PEC36SAAN	
LED3	1	LED, Yello (0603)	LITE-ONLTST-C190YKT	
L1, L2	2	Custom Transformer, 8-pin (9.0mm x 9.2mm)	Sumida CEP99-102	
P1, P2	2	2-circuit CLIK-Mate Vertical PCB Receptacle, 1.50mm pitch	Molex 5025840270	
R1, R2	2	470 ±5%, resistors (0805)		
R3, R4, R18	3	100kΩ ±5%, resistors (0603)		
R5, R6	2	47Ω ±5 resistors (0603)		
R7	1	100Ω ±5% resistors (0603)		
R8	1	10kΩ ±5% resistors (0603)		
R9-R11	3	470Ω ±5% resistors (0603)		
R12	1	1.5MΩ ±5% resistors (0603)		
R13	1	25.5kΩ ±1% resistors (0603)		
U1	1	Daisy-Chainable Analog Front End (16L TSSOP)	Maxim MAX17841BGUEV/+	Yes
U2	1	High-Performance Flash Microcontroller (6L SOT-23)	Microchip PIC10F222E/OT	
3.3V, 5V, RX_P (x2), TX_P (x2)	6	Multipurpose Test Points, Red	KEYSTONE 5010	Yes
-	6	Shunts	Sullins: STC02SYAN	Yes
-	1	PCB: MAX17841 EVKIT	Maxim MAX17841EVMINIQU#	Yes
NOT INSTALLED COMPONENTS				
ALRML-N, ALRML_N	0	Multipurpose Test Points, Black	KEYSTONE 5011	
ALRML-P, ALRML_P	0	Multipurpose Test Points, Red	KEYSTONE 5010	
C14, C15	0	Not Installed, 2200pF ±10%, 630V X7R ceramic capacitors, auto grade (1206)		
C16	0	Not Installed, 0.1µF ±10%, 50V X7R ceramic capacitor (0603)	Murata GRM188R71H104K	
C17, C18, C20-C23, C26, C27, C28	0	Not installed, ceramic capacitors (0603)		
C19	0	Not Installed, 0.1µF ±10%, 50V X7R ceramic capacitor (0603)		
D8	0	Not installed, Unidirectional ESD protection diodes (SOD323)		
JU6, JU7	0	Not Installed, 2 pin headers (0.1in centers)		
L3	0	Not Installed, Custom Transformer, 8-pin (9.0mm x 9.2mm)		
P3	0	Not installed, 2-circuit CLIK-Mate Vertical PCB Receptacle, 1.50mm pitch		
RX_CT, TX_CT, ALRML_CT	0	Not installed, miniature test points	KEYSTONE 5000	
R12	0	Not Installed, 1.5MΩ ±5% resistors (0603)		
R13	0	Not Installed, 25.5kΩ ±1% resistors (0603)		
R14, R15	0	Not Installed, 15kΩ ±5% resistors (0603)		
R16, R17	0	Not Installed, 10kΩ ±5% resistors (0603)		
U3	0	Not Installed, High-Speed, Low-Voltage Rail-to-Rail I/O Comparator	Maxim MAX987EUK+	

MAX17841B EV Kit Schematic

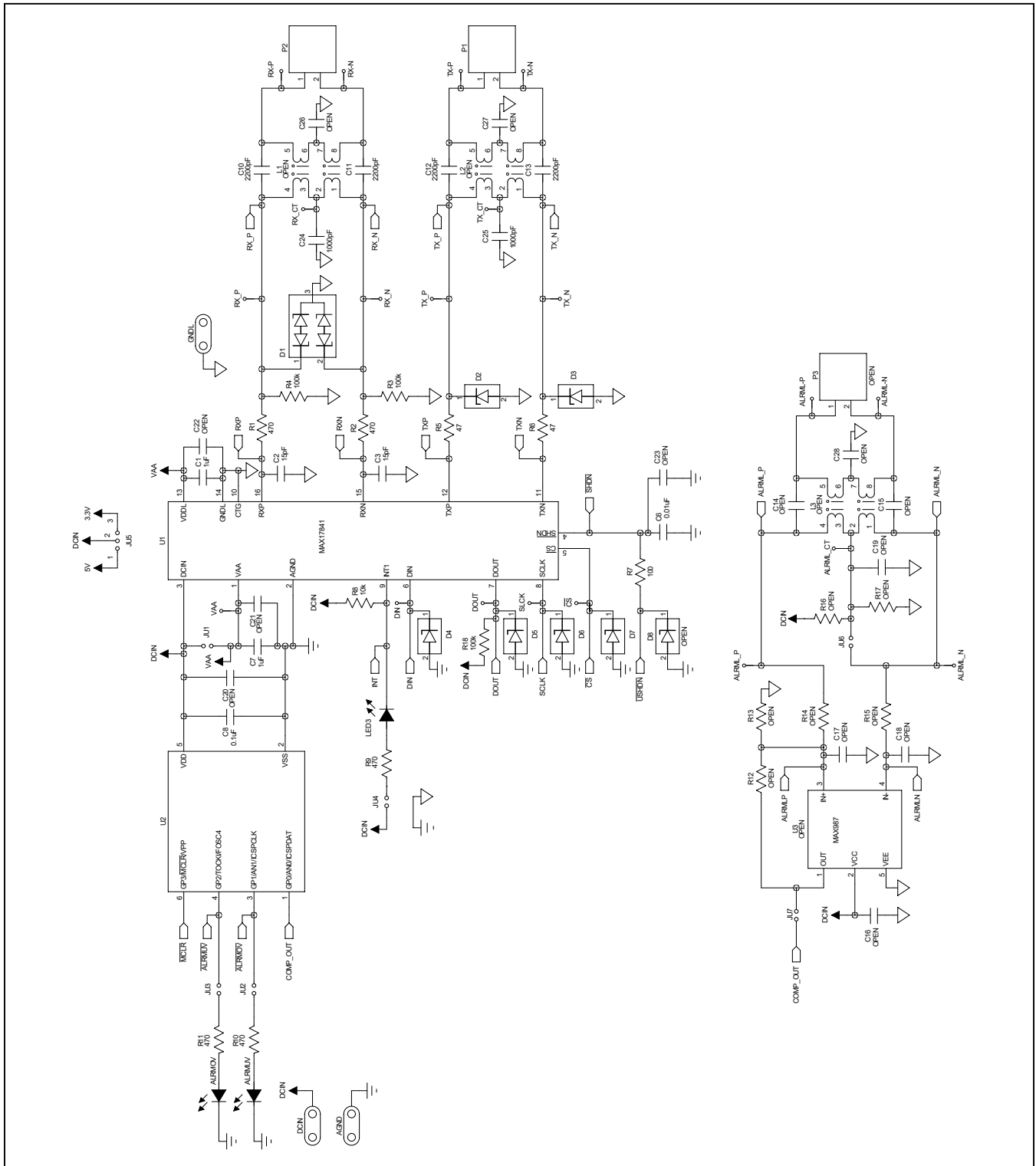

MAX17841B EV Kit Schematic (continued)

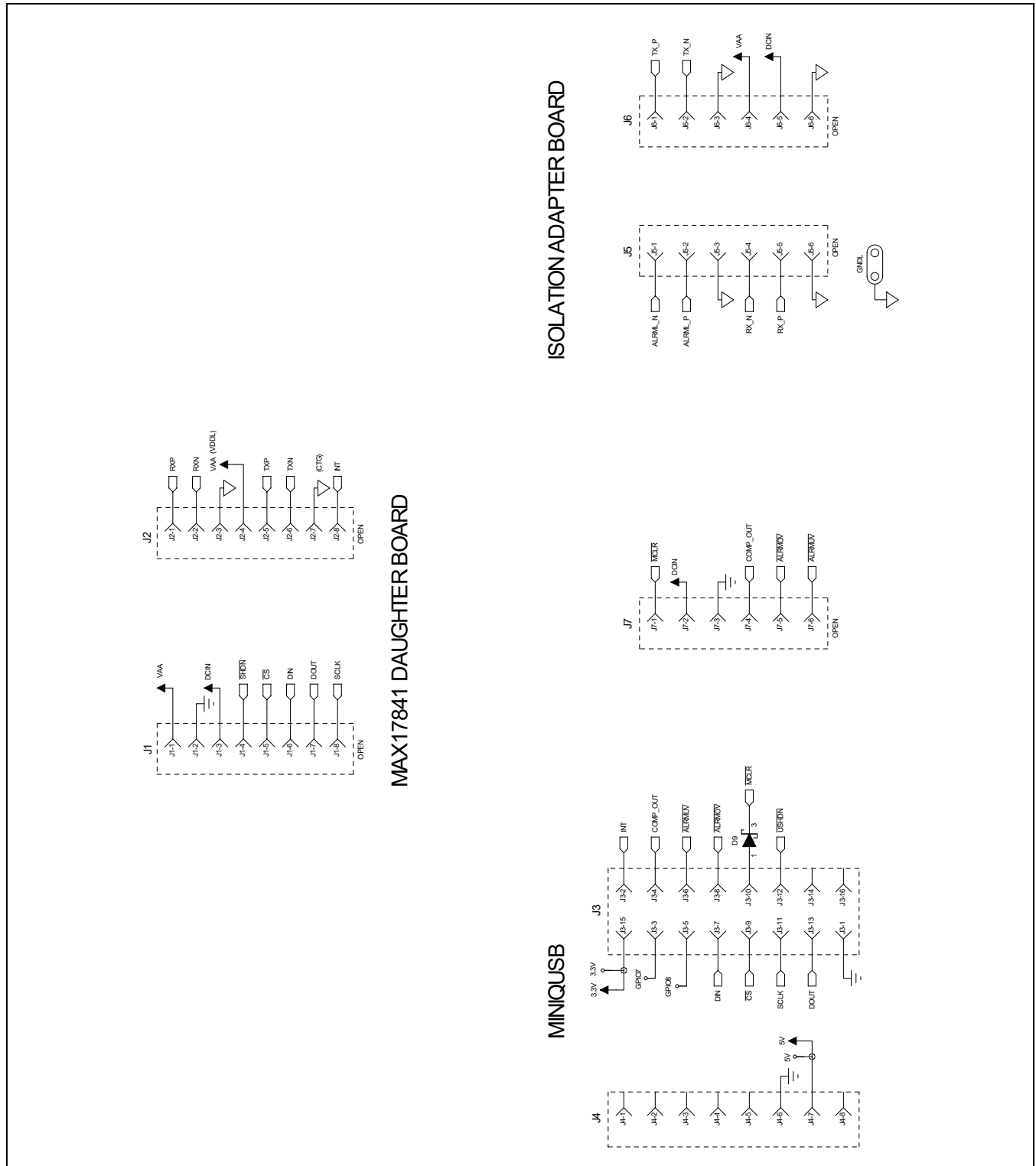

MAX17841B EV PCB Layouts

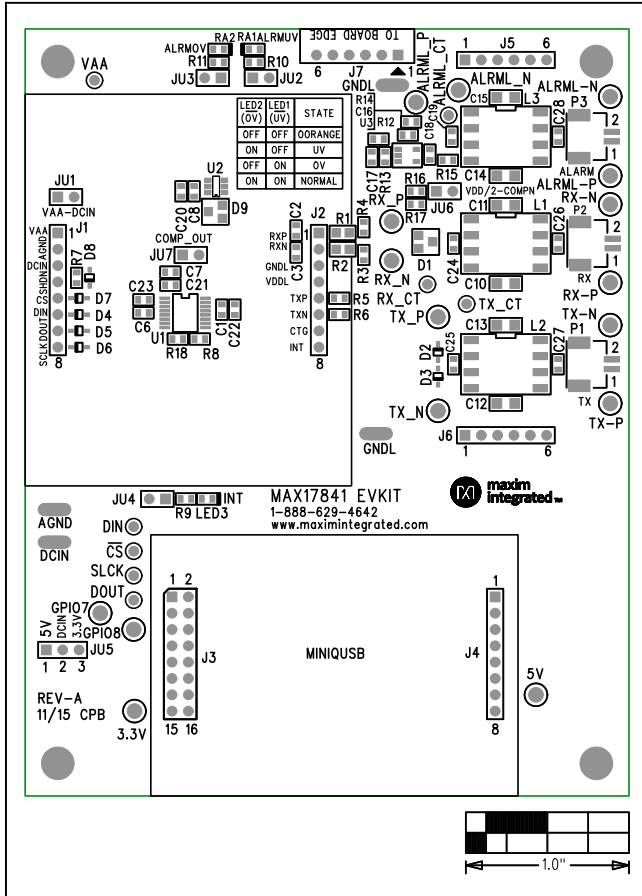

MAX17841B EV Kit Component Placement Guide—Top Silkscreen

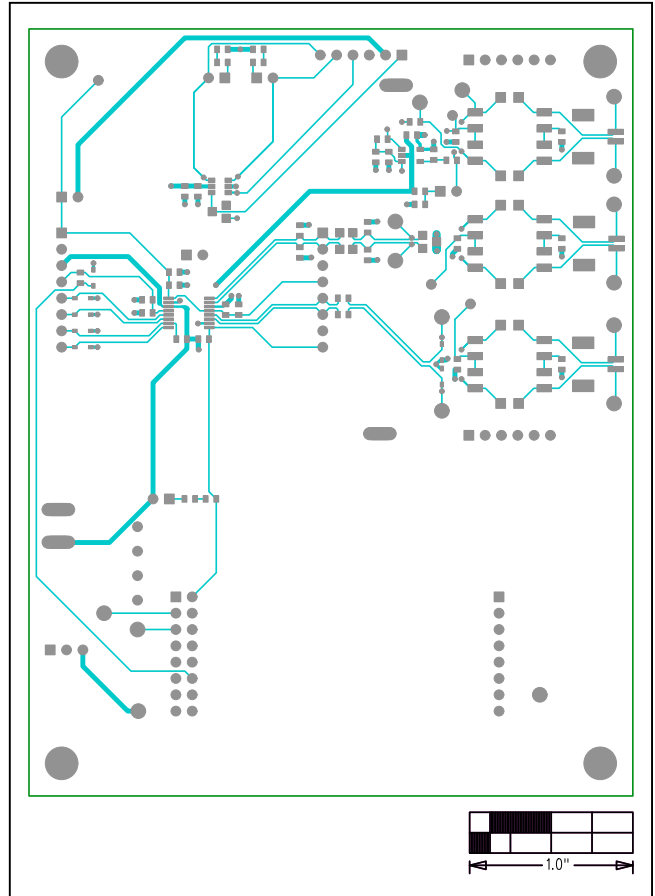

MAX17841B EV Kit PCB Layout—Component Side

MAX17841B EV PCB Layouts (continued)

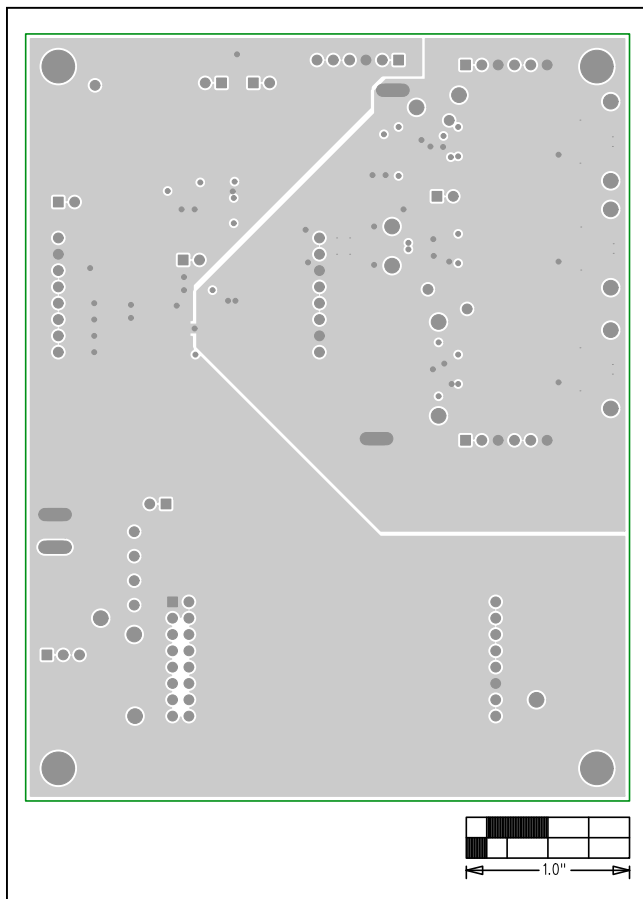

MAX17841B EV Kit PCB Layout—Layer 2 (GND)

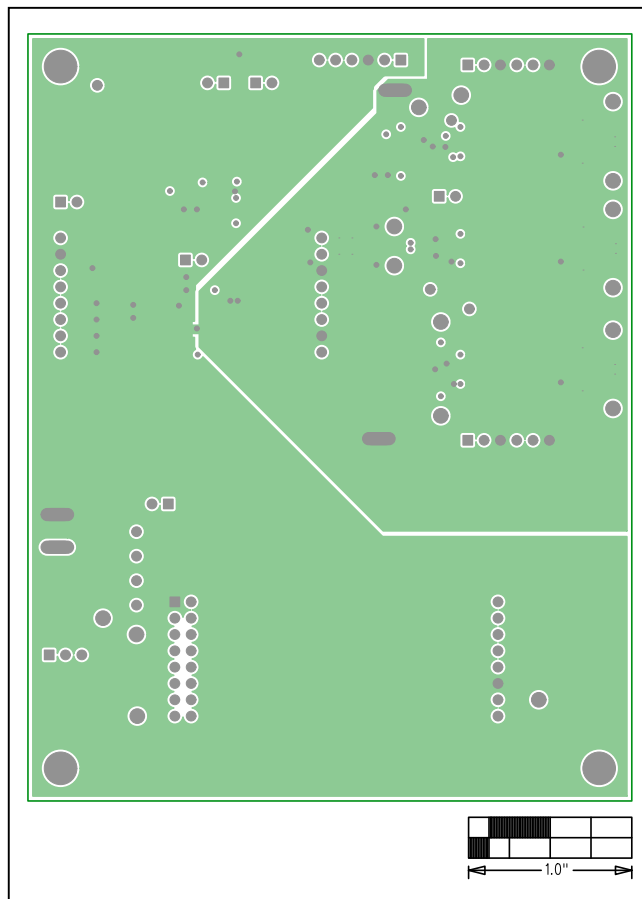

MAX17841B EV Kit PCB Layout—Layer 3 (GND)

MAX17841B EV PCB Layouts (continued)

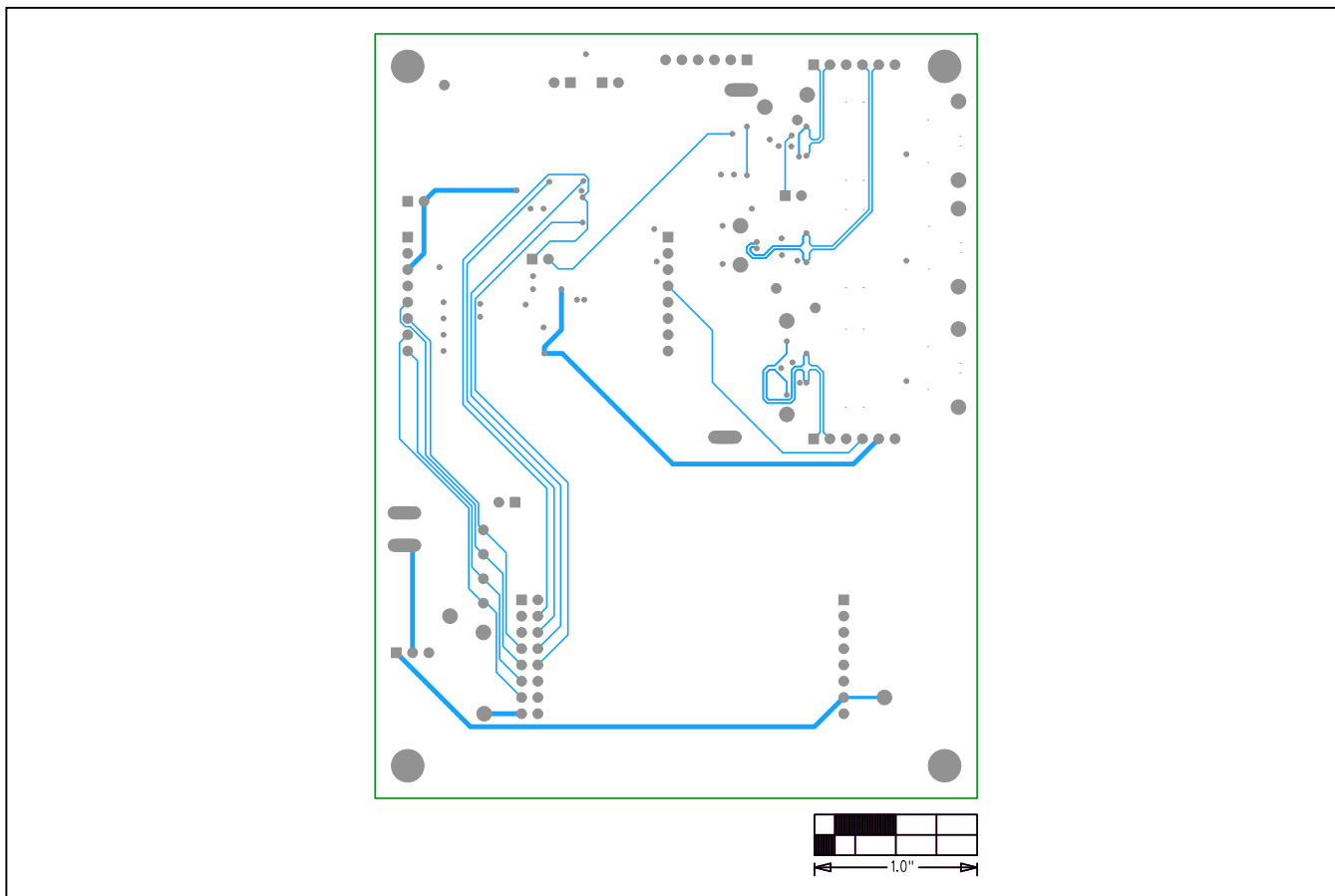

MAX17841B EV Kit PCB Layout—Solder Side