

## General Description

The MAX20012 evaluation kit (EV kit) demonstrates the MAX20012B automotive 2-channel step-down converters. The EV kit operates over a 3V to 5.5V input range. Output 1 is set for 0.98V and up to 24A load and output 2 is set for 0.95V and up to 12A load.

## Benefits and Features

- Differential Remote Voltage Sensing
- 3V to 5.5V Input Supply Range
- I<sup>2</sup>C-Controlled 0.5V to 1.5875V Output Voltage Range
- 2.2MHz Operation
- $\pm 2\%$  Output-Voltage Accuracy
- Power-Good Output
- Current-Mode, Forced-PWM, and Skip Operation
- Proven PCB Layout
- Fully Assembled and Tested

## EV Kit Contents

- MAX20012 EV Kit Board

## Quick Start

### Recommended Equipment

- MAX20012 EV kit
- 5V, 7A DC power supply
- Electronic load capable of 24A
- Digital voltmeter (DVM)

[Ordering Information](#) appears at end of data sheet.

## Procedure

The EV kit is fully assembled and tested. Follow the steps below to verify board operation. **Caution: Do not turn on supplies until all connections are completed.**

- 1) Verify that jumpers J4 and J5 have shunts placed across pins 1-2.
- 2) Connect the power supply between the PVDD and the PGND4 test points.
- 3) Preset the electronic load to 12A. Make sure the load is disabled.
- 4) Connect the electronic load between the OUT2 and the PGND2 test points. Use short high-gauge wires to ensure low voltage drop on the wires to help maintain voltage headroom on the load.
- 5) Connect the DVM between the OUT2 and PGND2 test points.
- 6) Turn on the power supply.
- 7) Enable the electronic load.
- 8) Verify that the voltage at the OUT2 test point is approximately 0.95V.
- 9) Disable the electronic load.
- 10) Turn off the power supply.
- 11) Disconnect the electronic load from the OUT2 and the PGND2 test points.
- 12) Disconnect the DVM from the OUT2 and the PGND2 test points.
- 13) Preset the electronic load up to 24A. Make sure the load is disabled.
- 14) Connect the electronic load between the OUT1 and the PGND1 test points. Use short high-gauge wires to ensure low voltage drop on the wires to help maintain voltage headroom on the load.
- 15) Connect the DVM between the OUT1 and the PGND1 test points.
- 16) Turn on the power supply.
- 17) Enable the electronic load.
- 18) Verify that the voltage at the OUT1 test point is approximately 0.98V.

## Detailed Description of Hardware

### EN1, EN2 Enable (J4, J5)

Place a shunt across pins 1-2 on jumper J4 for normal operation of output 1. Place a shunt across pins 1-2 on jumper J5 for normal operation of output 2. To disable either output, place the shunt across pins 2-3. When J4 and J5 are both shunted to GND, the IC is in shutdown mode and input current is reduced to 5µA (typ). See [Table 1](#).

### Synchronization Input/Output (SYNC)

The EV kit features a SYNC connection that allows for synchronization input or output. The function is set by the SO[1:0] bits, as defined in the MAX20012B IC data sheet. See [Table 2](#).

### I<sup>2</sup>C Slave Address (ADDR)

The EV kit provides jumper J6 to set the ADDR register. Pulldown resistor R19 is used to set ADDR = 0. If ADDR = 1 is desired, place a shunt across pins 1-2 on jumper J6. Refer to Table 1 in the MAX20012B IC data sheet for more details on the I<sup>2</sup>C slave address.

### Power-Good Output ( $\overline{\text{PGOOD}}$ )

The EV kit features an open-drain PG\_ output that asserts when the output voltage is between the PG\_UV and PG\_OV thresholds. PG\_ is asserted after the power-good active timeout period. An additional 220µs (typ) PG\_ delay exists following soft-start or DVS slewing. PG\_ is deasserted after a UV/OV propagation delay if the output voltage is outside the PG\_UV/OV thresholds. PG\_ is connected to a 1kΩ pullup resistor.

### Output Voltage

Output voltage is selectable using the VID registers (refer to Table 9 and Table 10 in the MAX20012B IC data sheet). Be aware of the VIDMAX registers (Table 4 in the IC data sheet), as this might limit the maximum output voltage.

### OUT1 Single-Phase Operation

OUT1 can be configured for single-phase operation. Remove inductor L3. Move the 0Ω resistor from R33 to R34.

**Table 1. EN1, EN2 Configuration (J4, J5)**

SHUNT POSITION	DESCRIPTION
Pins 1-2	Connects the EN pin to the voltage at PVDD for normal operation
Pins 2-3	Connects the EN pin to ground to enter shutdown mode

*\*Default position.*

**Table 2. SYNC Settings**

BIT	BIT DESCRIPTION
SO[1:0]	<b>SYNC I/O Select</b> 00 – Master: Input, rising edge starts cycle 01 – Master: Input, falling edge starts cycle 10 – Master: Output, falling edge starts cycle 11 – Unused

## Ordering Information

PART	TYPE
MAX20012EVKIT#	EV Kit

*#Denotes RoHS compliant.*

**MAX20012 EV Kit Bill of Materials**

REFERENCE DESIGNATORS	QTY	DESCRIPTION	MFG. PART NUMBERS	Y = Lead-free & RoHS Compliant R = RoHS Compliant Only N = Non-Compliant
C1, C10, C20, C22, C23, C24 C41, C42, C43	9	10uF 10%, 16V X7R ceramic capacitor (1206)	TDK C3216X7R1C106K	Y
C2, C11, C35	3	0.1uF 10%, 50V X7R ceramic capacitor (0603)	Murata GRM188R71H104K	
C3, C9, C12, C21	4	1uF 10%, 16V X7R ceramic capacitor (0603)	Murata GRM188R71C105K	
C4, C13, C36	3	0.01uF 10%, 50V X7R ceramic capacitor (0603)	Murata GRM188R71H103K	
C5, C6, C7, C8, C14, C15, C16, C17, C18, C19	10	47uF 10%, 6.3V X7R ceramic capacitor (1210)	Taiyo Yuden LMK325B7476MM	
C25	1	47uF, 50V aluminum electrolytic capacitor (E)	Panasonic EEE-FK1H470P	Y
PVDD, PVDD1, PVDD2, PVDD3, OUT1, OUT2, PGND1, PGND2, PGND3, PGND4, EN1, EN2, PG1, PG2, SYNC, SDA, SCL	17	WIRE, BUSS, 20G plated solid copper 0.25 inch U-shape wire loop		
J1	1	2X10 RIGHT ANGLE RECEPTACLE(0.1IN)	SAMTEC, SSW-110-02-S-D-RA	Y
J4, J5, J6	3	3 pin header, 2.54MM, Comes in 36-40 Pin Strips (CUT TO FIT)	SULLINS PEC36SAAN	Y
L1, L2, L3	3	0.1uH, 3.6mΩ typ@25C, inductor	Vishay IHLP2020BZERR10M01	Y
N1, N2, N3, N4, N5, N6	6	MOSFET, N-CH, 8.3mohm, 20V, 20A	Vishay SIS452DN	
R1, R7, R15	3	2.49K ohms 1% resistor (0402)		
R2, R6, R14	3	5.36K ohms 1% resistor (0402)		
R3, R4, R5, R8	4	1K ohms 1% resistor (0402)	Any	
R9, R10, R11, R12, R13, R18, R27, R28, R29, R30, R31, R32, R33	13	0 ohms 1% resistor (0402)	Any	Y
R16, R17	2	10K ohms 1% resistor (0402)	Any	
R19	1	100K ohms 1% resistor (0402)	Any	Y
U2	1	MOSFET Driver	Maxim MAX15492	
U1	1	Automotive Step-down Converter	Maxim MAX20012BATJCV+	Y
	2	Shunts	Kycon SX1100-B	Y
2 oz.	1	PCB: MAX20012 EVALUATION KIT#		
	0			
DO NOT POPULATE		DO NOT POPULATE		
C30, C31, C32, C33, C34, C37, C38	0	ceramic capacitor (0402)		
C39, C40	0	Poscap (E)		
D1, D2	0			
R20, R21, R22,R23, R24, R25, R26, R34, R39, R40	0			
J2, J3	0	2x5 receptacle		
J7, J8	0	2 pin header		

MAX20012 EV Kit Schematics

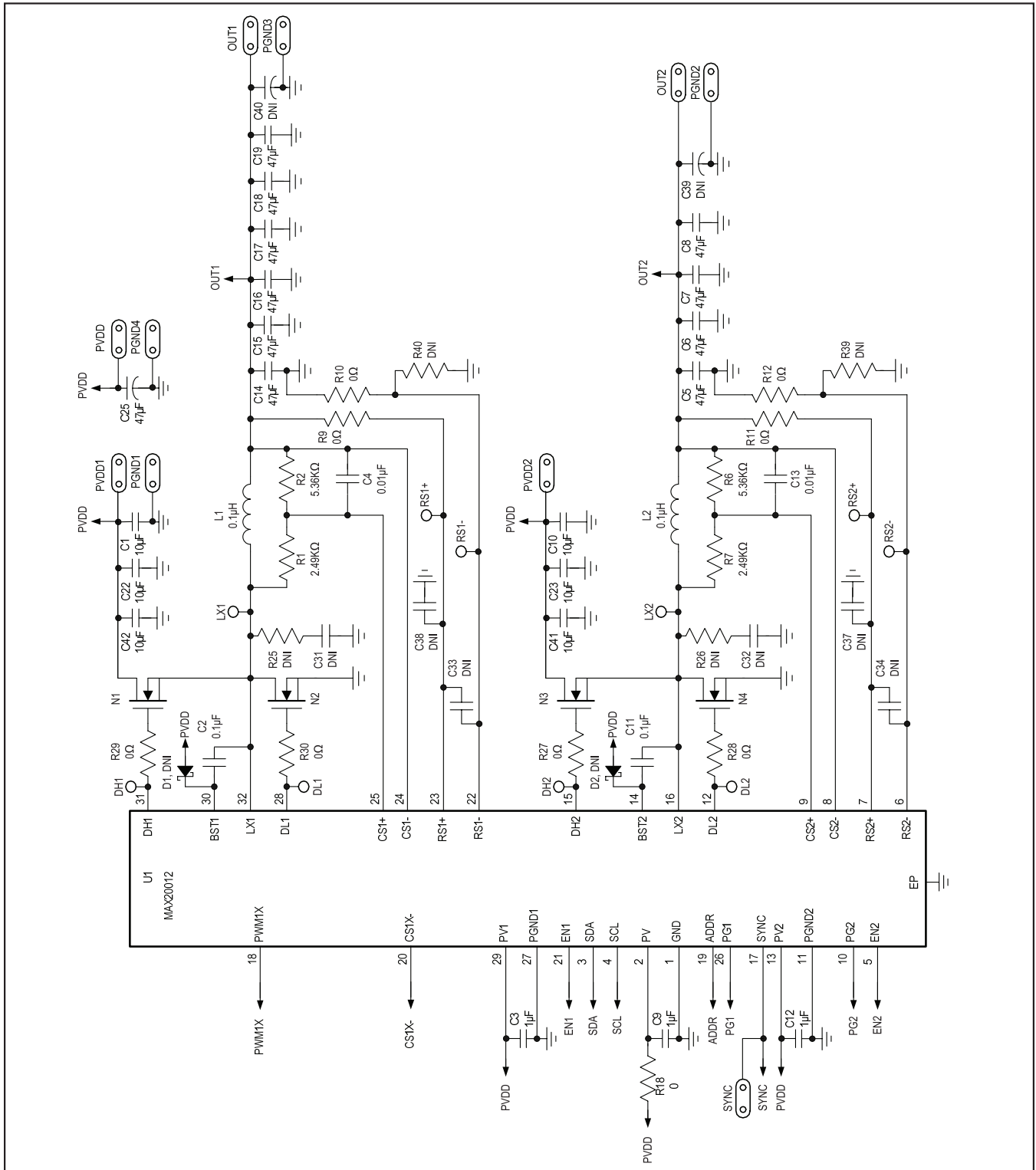

MAX20012 EV Kit Schematics (continued)

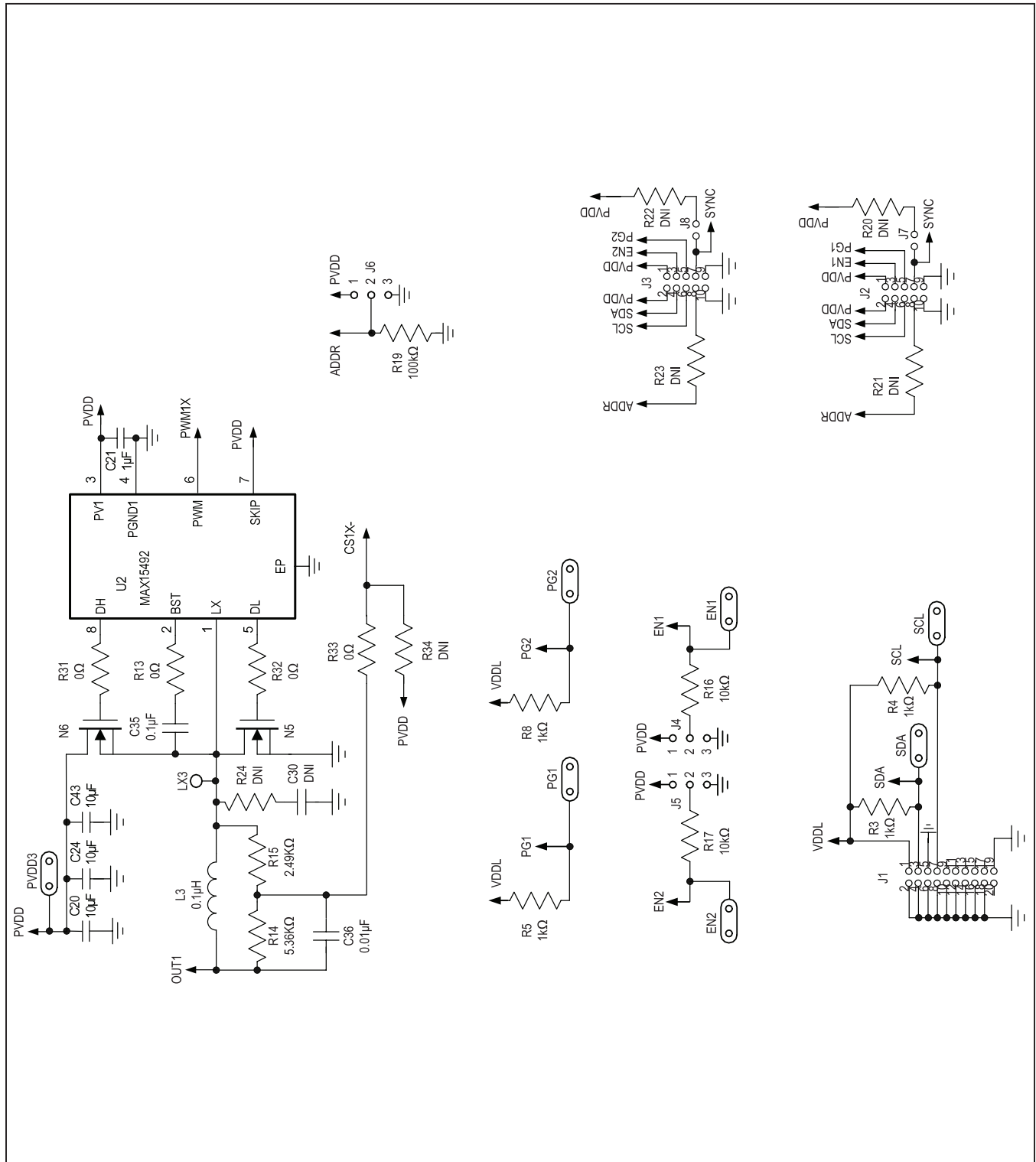

MAX20012 EV Kit PCB Layouts

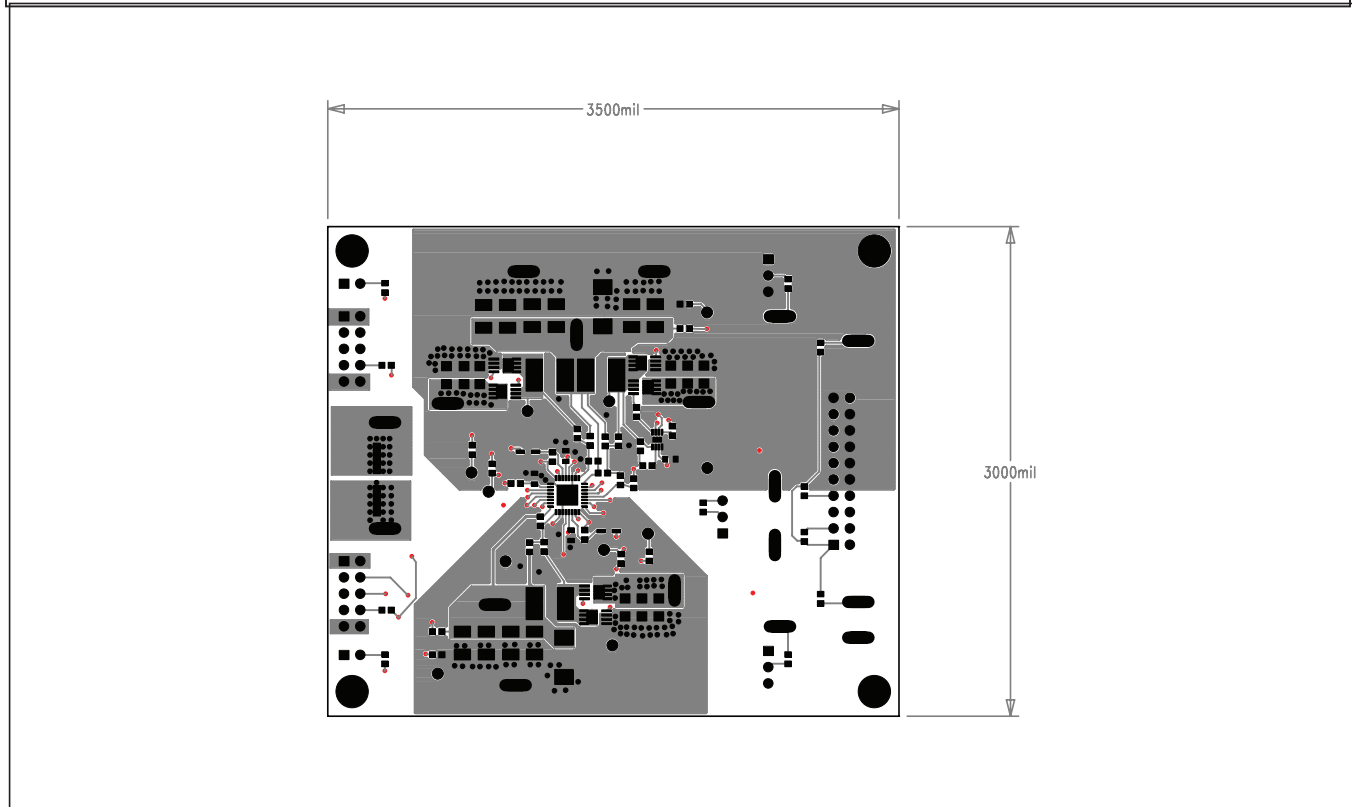
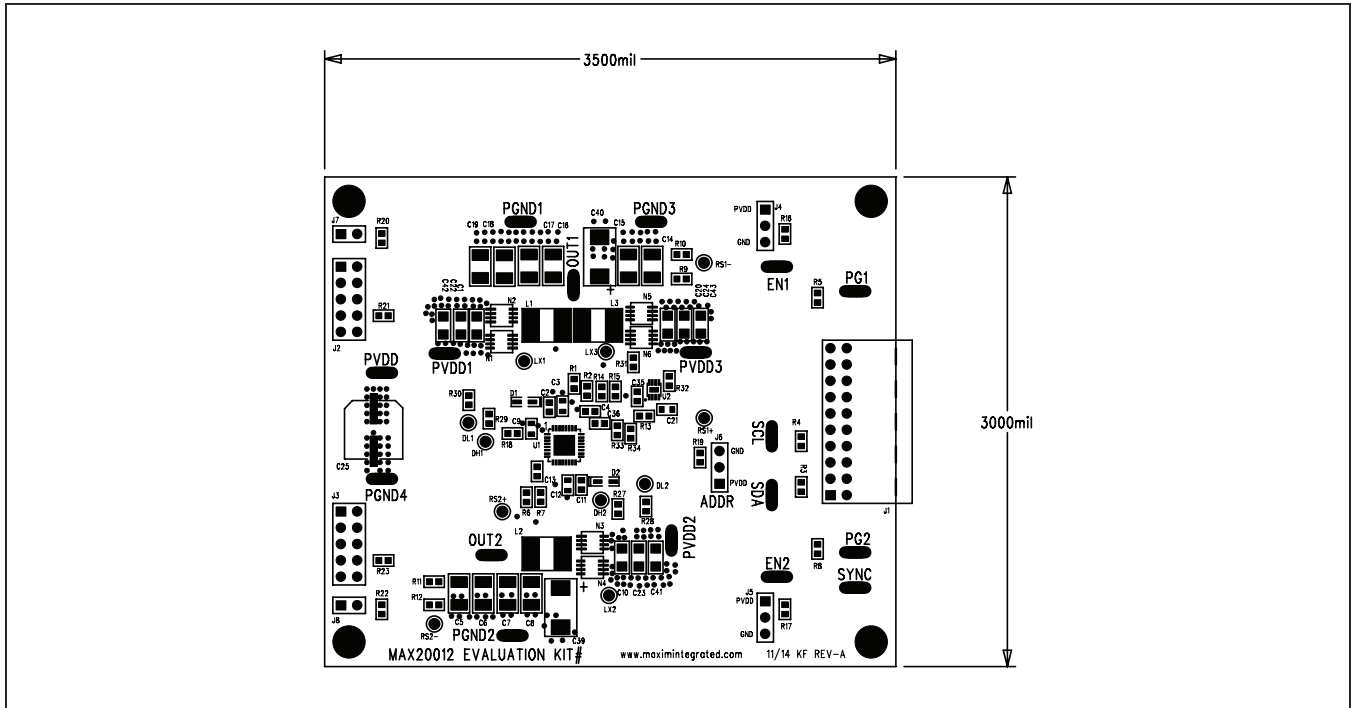

MAX20012 EV Kit PCB Layouts (continued)

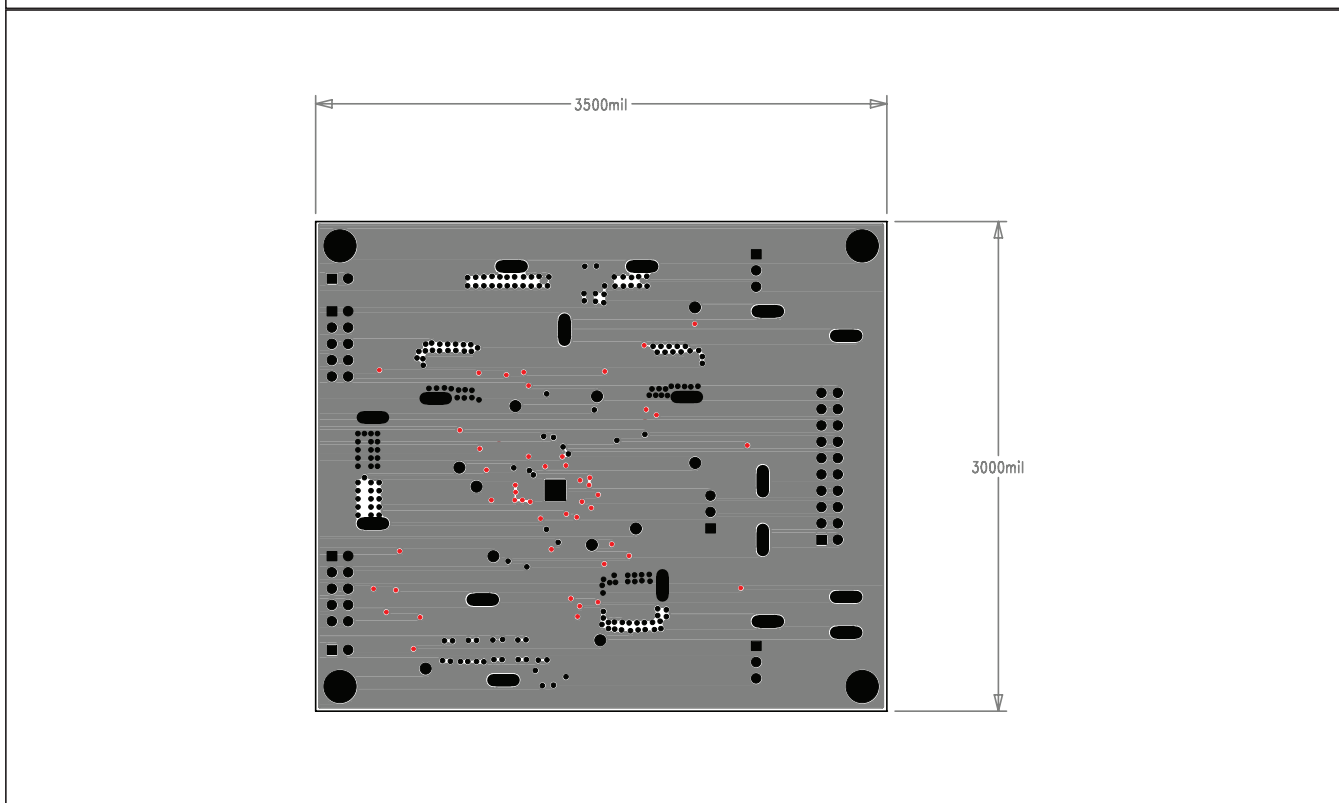
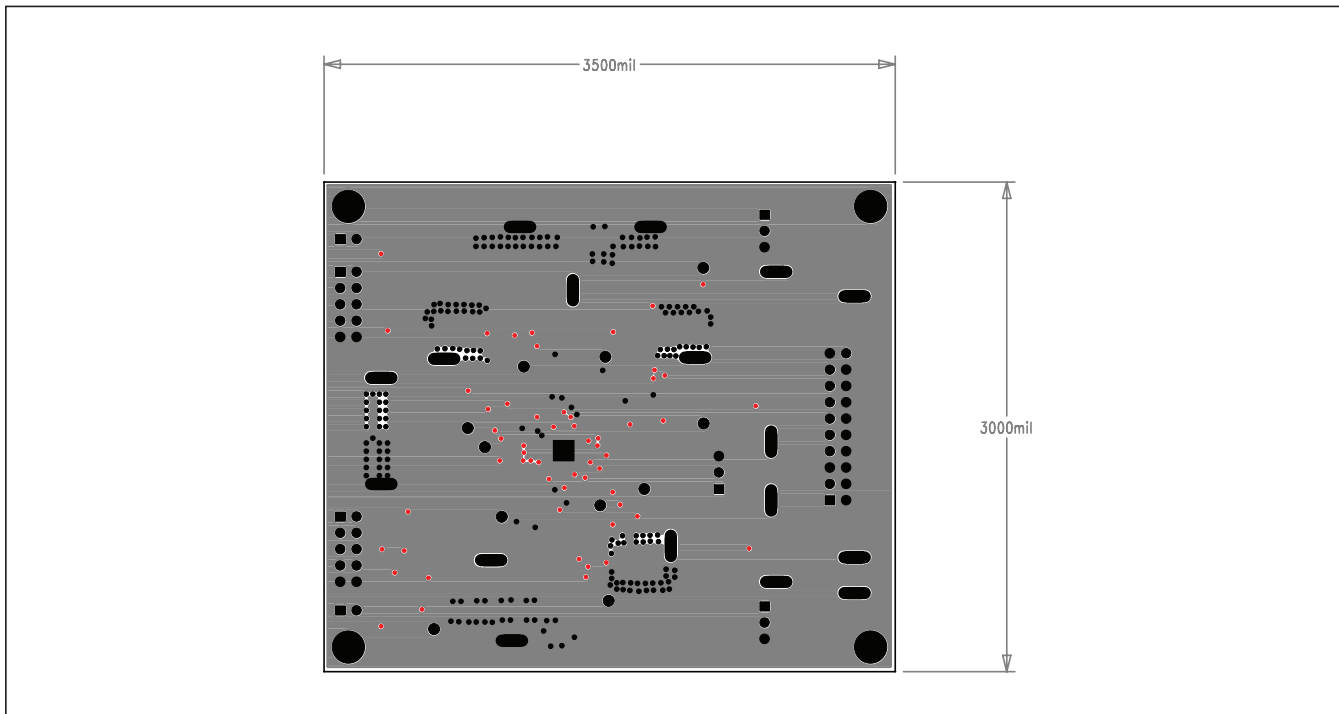

MAX20012 EV Kit PCB Layouts (continued)

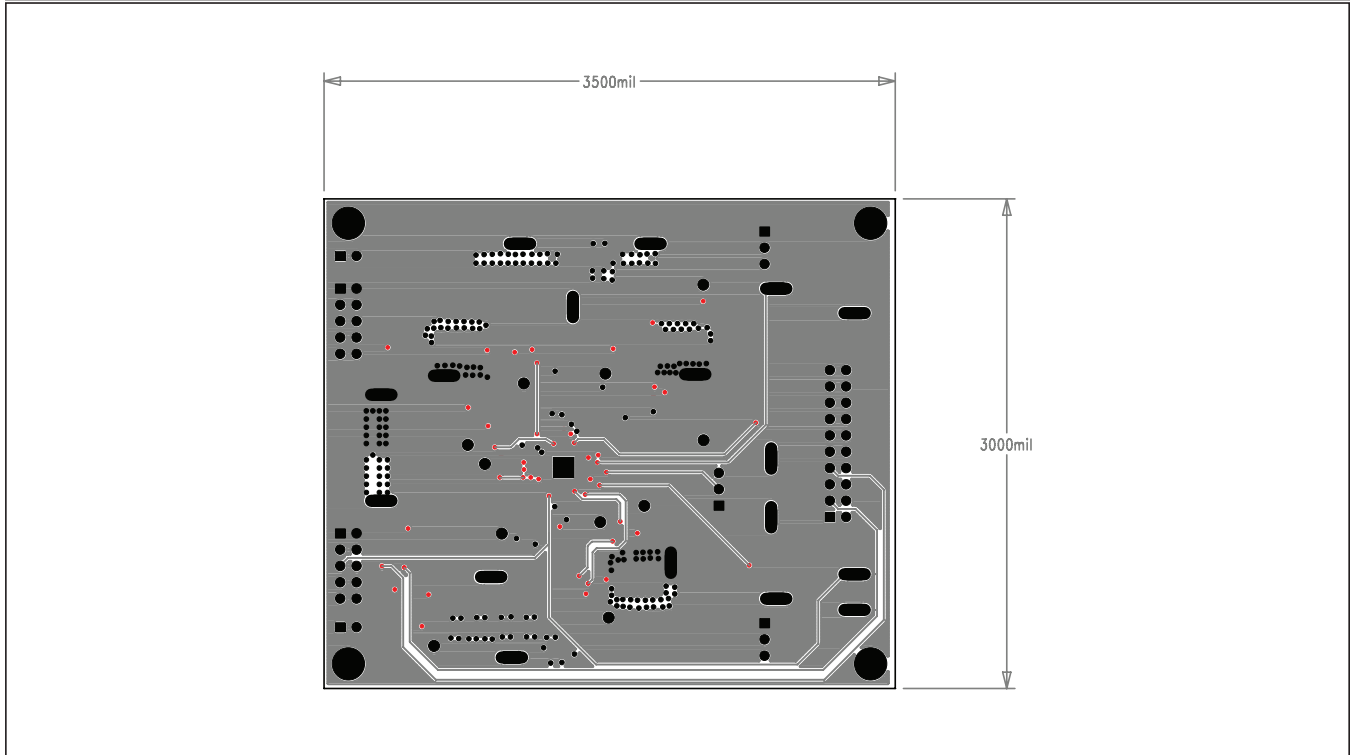
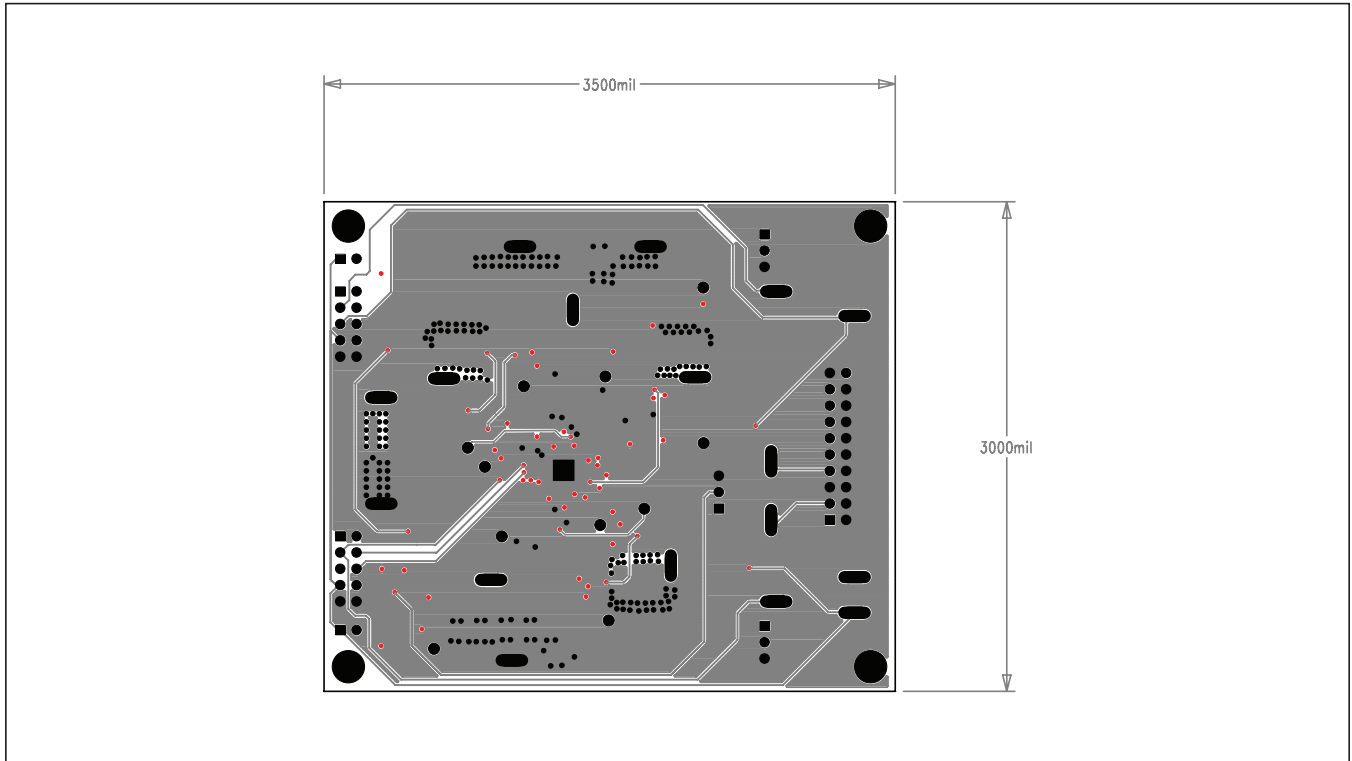



MAX20012 EV Kit PCB Layouts (continued)

