

Click [here](#) for production status of specific part numbers.

MAX20446

Automotive 6-Channel Backlight Driver with Boost/SEPIC Controller and I²C Interface

General Description

The MAX20446 is a 6-channel backlight driver with boost controller for automotive displays. The integrated current outputs can sink up to 130mA LED current each. The device accepts a wide 4.5V to 36V input voltage range and withstands direct automotive load-dump events.

The internal current-mode switching DC-DC controller supports boost or SEPIC topologies, and operates in the 400kHz to 2.2MHz frequency range. Integrated spread spectrum helps reduce EMI. An adaptive output-voltage-control scheme minimizes power dissipation in the LED current-sink paths.

The device features I²C-controlled pulse-width modulation (PWM) dimming and hybrid dimming. In either case, the minimum pulse width is 500ns. Phase-shifted dimming of the strings is incorporated for lower EMI.

Comprehensive diagnostic information is also available through the I²C interface.

The MAX20446 is available in a 24-pin TQFN package and operates in the -40°C to +125°C temperature range.

Applications

- Infotainment Displays
- Central Information Displays
- Instrument Clusters

Benefits and Features

- Wide-Voltage-Range Operation
 - Operates Down to 4V Supply After Startup
 - Survives Load Dump Up to 52V
- High Integration
 - Complete 6-Channel Solution Including Boost Controller
 - I²C Control for Minimum Parts Count
- Robust and Low EMI
 - Spread-Spectrum Oscillator
 - Phase Shifting
 - 400kHz to 2.2MHz Switching-Frequency Range
 - Fail-Safe Operation Mode Using the FSEN Pin
- Versatile Dimming Scheme Allows Hybrid or PWM-Only Dimming Using DIM Input or I²C
 - Dimming Ratio > 10000:1 Using Hybrid Dimming
 - 10000:1 Dimming Ratio at 200Hz using PWM Dimming
- Complete Diagnostics
 - LED Open/Short Detection and Protection
 - Boost Output Undervoltage and Overvoltage
 - Boost Voltage
 - Individual String LED Current
 - Thermal Shutdown
- Compact (4mm x 4mm) 24-Pin TQFN Package

[Ordering Information](#) appears at end of data sheet.

Absolute Maximum Ratings

IN, EN, OUT_, BSTMON, PGATE to GND-0.3V to +52V
 PGND, LEDGND to GND-0.3V to +0.3V
 V_{CC} to GND -0.3V to maximum of (+6V, V_{IN} + 0.3V)
 FLTB, SCL, SDA, DIM to GND.....-0.3V to +6V
 CS, RT, COMP, NDRV, IREF,
 FSEN to GND-0.3V to V_{CC} + 0.3V
 NDRV Peak Current (< 100ns) -5A to +5A
 NDRV Continuous Current -100mA to +100mA
 OUT_ Continuous Current..... -100mA to +150mA

Continuous Power Dissipation Multilayer Board
 (T_A = +70°C).....2.857W
 ESDHB -2kV to +2kV
 ESDMM-200V to +200V
 Operating Temperature Range..... -40°C to +125°C
 Junction Temperature Range -40°C to +150°C
 Storage Temperature Range -65°C to +150°C
 Lead Temperature (soldering, 10s) +300°C

Stresses beyond those listed under "Absolute Maximum Ratings" may cause permanent damage to the device. These are stress ratings only, and functional operation of the device at these or any other conditions beyond those indicated in the operational sections of the specifications is not implied. Exposure to absolute maximum rating conditions for extended periods may affect device reliability.

Package Information

TQFN

PACKAGE CODE	T2444+4C
Outline Number	21-0139
Land Pattern Number	90-0022
Thermal Resistance, Single-Layer Board:	
Junction to Ambient (θ _{JA})	48°C/W
Junction to Case (θ _{JC})	3°C/W
Thermal Resistance, Four-Layer Board:	
Junction to Ambient (θ _{JA})	36°C/W
Junction to Case (θ _{JC})	3°C/W

For the latest package outline information and land patterns (footprints), go to www.maximintegrated.com/packages. Note that a "+", "#", or "-" in the package code indicates RoHS status only. Package drawings may show a different suffix character, but the drawing pertains to the package regardless of RoHS status.

Package thermal resistances were obtained using the method described in JEDEC specification JESD51-7, using a four-layer board. For detailed information on package thermal considerations, refer to www.maximintegrated.com/thermal-tutorial.

Electrical Characteristics

(V_{IN} = 12V, R_{RT} = 76.8kΩ, C_{VCC} = 1μF, T_A = T_J = -40°C to +125°C, unless otherwise noted. Limits are 100% tested at T_A = +25°C. Limits over the operating temperature range and relevant supply voltage range are guaranteed by design and characterization.)

PARAMETER	SYMBOL	CONDITIONS	MIN	TYP	MAX	UNITS
POWER INPUT						
Input Operating Range			4.5		36	V
Input Voltage Range After Startup			4.2		36	V
Input Operating Range		IN pin connected to V _{CC}	4.5		5.5	V
Quiescent Supply Current		V _{DIM} = 5V, V _{BSTMON} = 1.3V, OUT1–OUT6 unconnected		10	15	mA
Standby Supply Current		V _{IN} = 12V, V _{EN} = 0V		0.1	1	μA
Undervoltage Lockout, Rising			3.8	4.15	4.45	V

Electrical Characteristics (continued)

($V_{IN} = 12V$, $R_{RT} = 76.8k\Omega$, $C_{VCC} = 1\mu F$, $T_A = T_J = -40^\circ C$ to $+125^\circ C$, unless otherwise noted. Limits are 100% tested at $T_A = +25^\circ C$. Limits over the operating temperature range and relevant supply voltage range are guaranteed by design and characterization.)

PARAMETER	SYMBOL	CONDITIONS	MIN	TYP	MAX	UNITS
Undervoltage Lockout, Falling			3.1	3.7	4	V
Startup Delay		From EN high to I ² C ready			2	ms
V_{CC} REGULATOR						
V _{CC} Output Voltage		$5.75V < V_{IN} < 36V$; $I_{VCC} = 1mA$ to $10mA$	4.75	5	5.25	V
Dropout Voltage		$V_{IN} = 4.5V$, $I_{VCC} = 5mA$			0.2	V
Short-Circuit Current Limit		V _{CC} shorted to GND		60		mA
V _{CC} Undervoltage-Lockout Threshold, Rising			4.05	4.2	4.35	V
V _{CC} Undervoltage-Lockout Threshold, Falling			3.75	3.9	4.04	V
RT OSCILLATOR						
Switching-Frequency Range	f _{SW}	Frequency dithering disabled	400		2200	kHz
Maximum Duty Cycle		f _{SW} = 400kHz	90	94.5	98.5	%
		f _{SW} = 2200kHz	86	90.5	95	
Oscillator Frequency Accuracy		f _{SW} = 400kHz to 2200kHz, frequency dither disabled	-10		+10	%
Frequency Dither	SS	SSL bit = 1		±3		%
RT Output Voltage	V _{RT}	$R_{RT} = 76.8k\Omega$ or $R_{RT} = 13.3k\Omega$	1.2	1.25	1.3	V
Sync Rising Threshold			3			V
Sync Frequency Duty-Cycle Range				50		%
Sync Frequency Range			1.2 x f _{SW}		1.5 x f _{SW}	kHz
MOSFET DRIVER						
NDRV On-Resistance, High Side		NDRV sinking 30mA		1.5	3	Ω
NDRV On-Resistance, Low Side		NDRV sourcing 30mA		0.8	1.6	Ω
NDRV Rise Time		C _{LOAD} = 1nF		8		ns
NDRV Fall Time		C _{LOAD} = 1nF		8		ns
SLOPE COMPENSATION						
Peak Slope-Compensation Current-Ramp Magnitude		Current ramp added to CS	42	50	58	μA
CURRENT-SENSE COMPARATOR						
Current-Limit Threshold	V _{CL_MAX}	Includes internal slope-ramp magnitude, $V_{CL} = V_{CS} + \text{slope-compensation voltage}$	390	420	450	mV
ERROR AMPLIFIER						
OUT_Regulation High Threshold		V _{OUT_falling}	0.95	1.03	1.1	V

Electrical Characteristics (continued)

($V_{IN} = 12V$, $R_{RT} = 76.8k\Omega$, $C_{VCC} = 1\mu F$, $T_A = T_J = -40^\circ C$ to $+125^\circ C$, unless otherwise noted. Limits are 100% tested at $T_A = +25^\circ C$. Limits over the operating temperature range and relevant supply voltage range are guaranteed by design and characterization.)

PARAMETER	SYMBOL	CONDITIONS	MIN	TYP	MAX	UNITS
OUT_ Regulation Low Threshold		V_{OUT_rising}	0.7	0.78	0.85	V
Transconductance			480	700	920	μS
COMP Sink Current		$V_{COMP} = 2V$	200	480	800	μA
COMP Source Current		$V_{COMP} = 1V$	200	480	800	μA
LED CURRENT SINKS						
IREF Voltage	V_{IREF}	$R_{IREF} = 49.9k\Omega$	1.2	1.25	1.3	V
OUT_ Output Current		120mA setting	115	120	125	mA
		100mA setting	96	100	104	
		50mA setting	48	50	52	
Channel-to-Channel Matching		$I_{OUT_} = 120mA$	-2		+2	%
		$I_{OUT_} = 50mA$	-2.5		+2.5	
Total OUT_ Leakage Current to IN	$I_{OUTLEAK}$	$V_{OUT_} = 48V$, $V_{DIM} = 0V$, all OUT_ pins shorted together		8	12	μA
OUT_ Current Rise Time		10% to 90% $I_{OUT_}$		150		ns
OUT_ Current Fall Time		90% to 10% $I_{OUT_}$		50		ns
DIM Sampling Frequency				20		MHz
LOGIC INPUT AND OUTPUTS						
EN Input Logic-High			2.1			V
EN Input Logic-Low					0.8	V
EN Input Current		$V_{EN} = 5V$		3	5	μA
DIM, SDA, SCL Input Logic-High			2.1			V
DIM, SDA, SCL Input Logic-Low					0.8	V
DIM Input-Pullup Current				5		μA
FSEN Input-Voltage Threshold High		FSEN rising	1.8	2		V
FSEN Input Logic-Low	V_{FSENIL}	FSEN falling		76.5		mV
FSEN Input Current	I_{FSEN}	$V_{FSEN} = 1V$		15		μA
SDA, FLTB Output Low Voltage		Sinking 3mA			0.4	V
FLTB Output-Leakage Current		$V_{FLTB} = 5.5V$	-1		+1	μA
OVERVOLTAGE AND UNDERVOLTAGE PROTECTION						
BSTMON Overvoltage Trip Threshold		BSTMON rising	1.18	1.23	1.28	V
BSTMON Hysteresis				70		mV
BSTMON Input Bias Current		$0V < V_{BSTMON} < 1.3V$	-500		500	nA

Electrical Characteristics (continued)

($V_{IN} = 12V$, $R_{RT} = 76.8k\Omega$, $C_{VCC} = 1\mu F$, $T_A = T_J = -40^\circ C$ to $+125^\circ C$, unless otherwise noted. Limits are 100% tested at $T_A = +25^\circ C$. Limits over the operating temperature range and relevant supply voltage range are guaranteed by design and characterization.)

PARAMETER	SYMBOL	CONDITIONS	MIN	TYP	MAX	UNITS
BSTMON Undervoltage-Detection Threshold		BSTMON falling, PGATE latched off	0.4	0.43	0.46	V
Boost Undervoltage Blanking Time		After ENA is written to '1'	47.8	52	56.2	ms
BSTMON Undervoltage-Detection Delay		BSTMON falling	4	10	18	μs
PGATE Pulldown Current			170	200	230	μA
PGATE Start Delay		Delay between PGATE going low and boost converter starting		2	2.2	ms
PGATE Leakage Current		$V_{PGATE} = 12V$, $V_{EN} = 0V$		0.1	1	μA
LED FAULT DETECTION						
LED Short-Detection Threshold		SLDET[1:0]=0x01	2.8	3	3.25	V
		SLDET[1:0]=0x10	5.6	6	6.4	
		SLDET[1:0]=0x11	7.5	8	8.5	
Short-Detection Comparator Delay				9		μs
OUT_ Check-LED Source Current			50	60	70	μA
OUT_ Short-to-GND Detection Threshold		Before boost converter startup	250	300	365	mV
OUT_ Unused-Detection Threshold			1.15	1.25	1.35	V
OUT_ Open-LED Detection Threshold		During operation	250	300	365	mV
ANALOG-TO-DIGITAL CONVERTER						
ADC Measurement Resolution				8		Bits
Total Measurement Error, Current		$I_{OUT_} = 120mA$			± 8	mA
Total Measurement Error, Voltage		$V_{BSTMON} = 1V$	-70		+70	mV
ADC Gain Error		$I_{OUT_} = 120mA$	-4		+6	%
ADC Offset Error		$I_{OUT_} = 120mA$			± 4	LSB
Measurement Resolution, Current				0.5		mA
Measurement Resolution, Voltage				5.1		mV
THERMAL SHUTDOWN						
Thermal Warning				125		$^\circ C$
Thermal-Shutdown Threshold				165		$^\circ C$
Thermal-Shutdown Hysteresis				15		$^\circ C$

Electrical Characteristics (continued)

($V_{IN} = 12V$, $R_{RT} = 76.8k\Omega$, $C_{VCC} = 1\mu F$, $T_A = T_J = -40^\circ C$ to $+125^\circ C$, unless otherwise noted. Limits are 100% tested at $T_A = +25^\circ C$. Limits over the operating temperature range and relevant supply voltage range are guaranteed by design and characterization.)

PARAMETER	SYMBOL	CONDITIONS	MIN	TYP	MAX	UNITS
I²C INTERFACE						
Serial-Clock Frequency	f_{SCL}				400	kHz
Bus-Free Time Between STOP and START Condition	t_{BUF}		1.3			μs
START Condition Setup Time	$t_{SU:STA}$		0.6			μs
START Condition Hold Time	$t_{HD:STA}$		0.6			μs
STOP Condition Setup Time	$t_{SU:STO}$		0.6			μs
Clock Low Period	t_{LOW}		1.3			μs
Clock High Period	t_{HIGH}		0.6			μs
Data Setup Time	$t_{SU:DAT}$		100			ns
Data Hold Time	$t_{HD:DAT}$	Measured from 50% point on SCL falling edge to SDA edge	0			μs
Pulse Width of Spike Suppressed	t_{SP}			50		ns

Typical Operating Characteristics

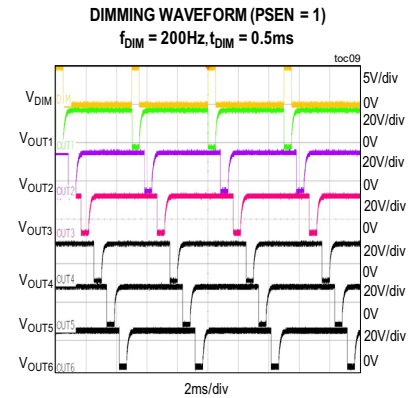
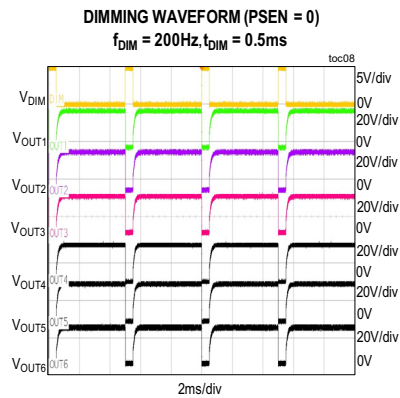
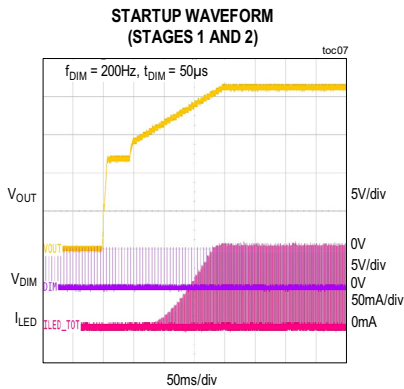
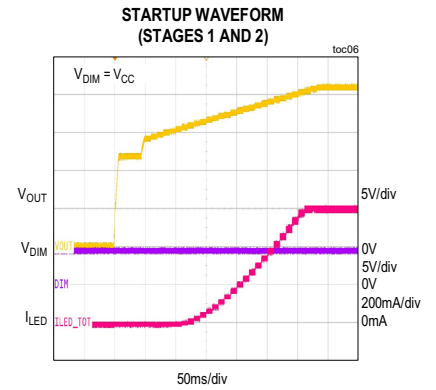
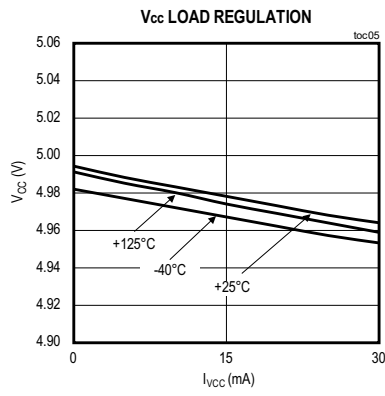
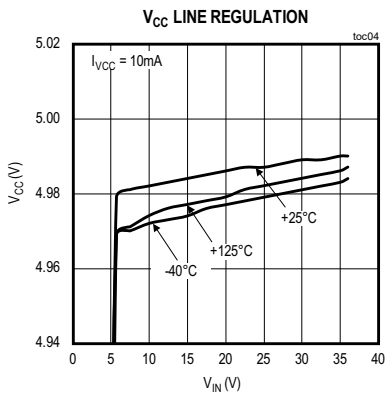
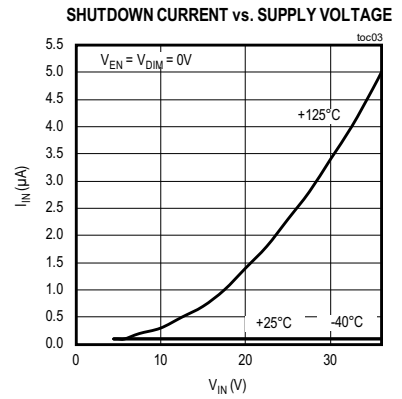
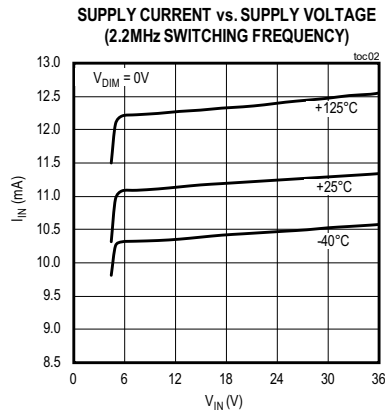
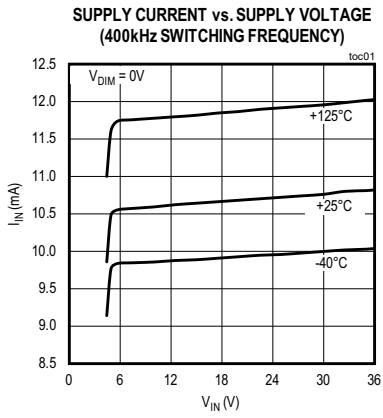

Typical Operating Characteristics (continued)

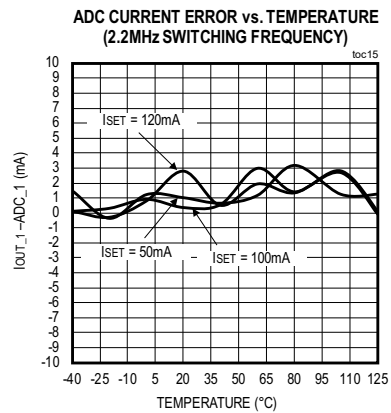
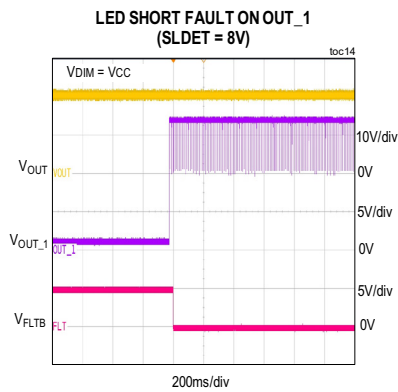
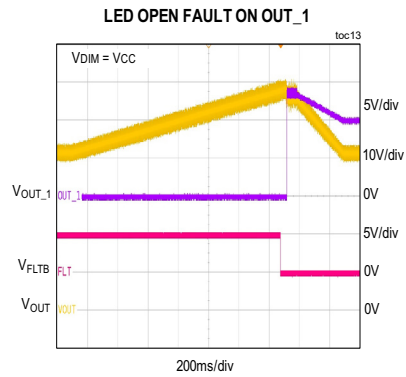
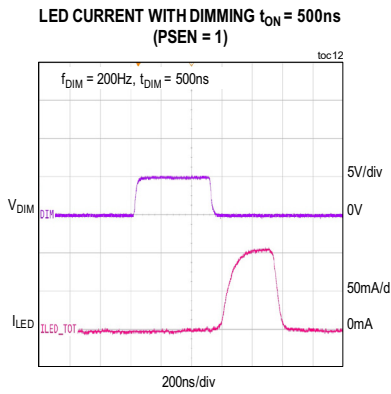
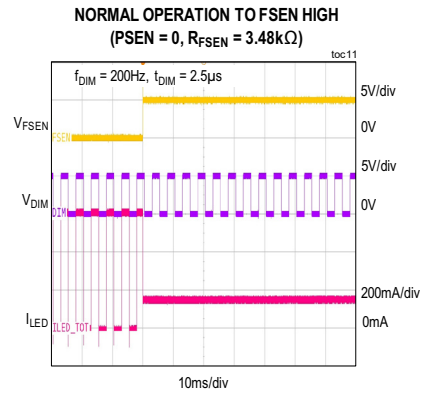
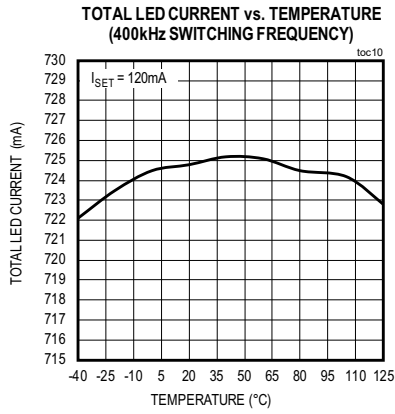

Pin Configuration

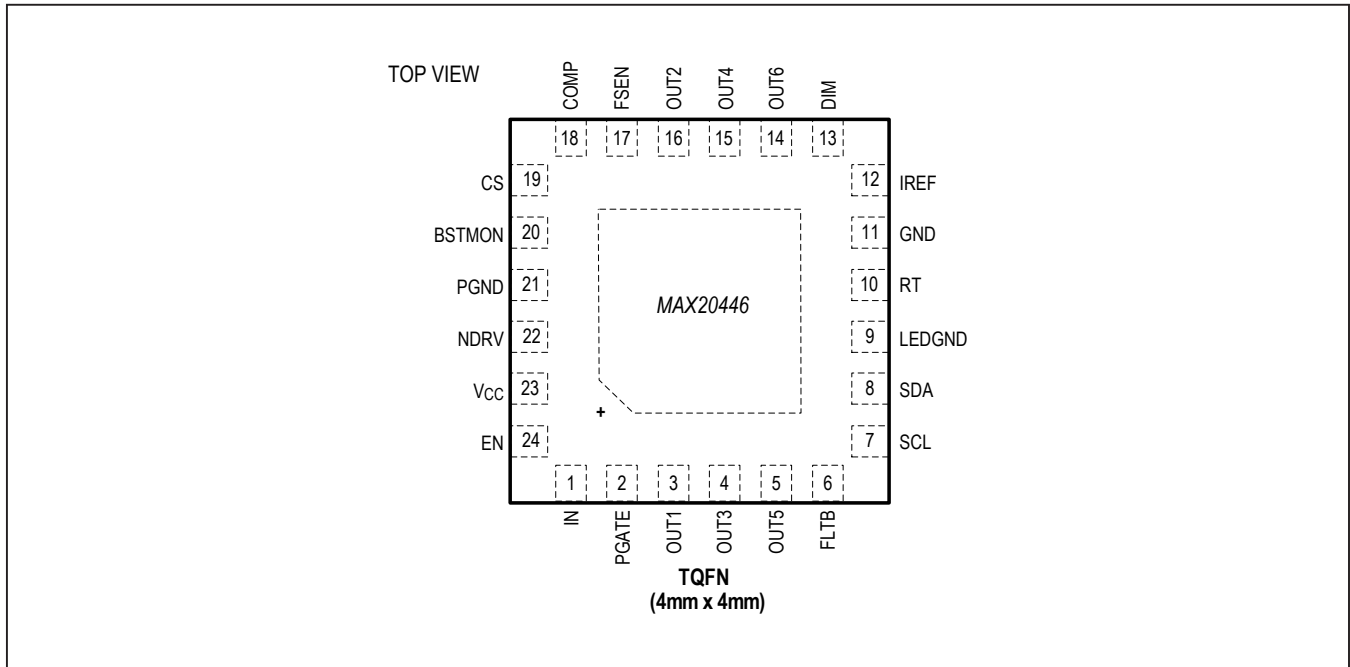

Pin Description

PIN	NAME	FUNCTION
1	IN	Bias Supply Input. Connect a 4.5V to 36V supply to IN. Bypass IN to GND with a 2.2µF ceramic capacitor.
2	PGATE	Gate Connection for External Series pMOSFET
3	OUT1	LED String Cathode Connection 1. OUT1 is the open-drain output of the linear current sink that controls the current through the LED string connected to OUT1. OUT1 sinks up to 120mA.
4	OUT3	LED String Cathode Connection 3. OUT3 is the open-drain output of the linear current sink that controls the current through the LED string connected to OUT3. OUT3 sinks up to 120mA.
5	OUT5	LED String Cathode Connection 5. OUT5 is the open-drain output of the linear current sink that controls the current through the LED string connected to OUT5. OUT5 sinks up to 120mA.
6	FLT B	Open-Drain Fault Output. FLT B asserts low when any diagnostic bit (that is not masked) is asserted. See the <i>Fault Protection</i> section for more details. Connect a pullup resistor from FLT B to V _{CC} or to a 5V (max) logic supply.
7	SCL	I ² C Clock Input. Connect a pullup resistor from SCL to the logic supply.
8	SDA	I ² C Data I/O Pin. Connect a pullup resistor from SDA to the logic supply.
9	LEDGND	LED Ground. LEDGND is the return path connection for the linear current sinks. Connect GND, LEDGND, and PGND at a single point.
10	RT	Oscillator Timing Resistor Connection. Connect a timing resistor (R _{RT}) from RT to GND to program the switching frequency. In addition, connect a 100pF capacitor from RT to GND. To synchronize the switching frequency with an external clock, apply an AC-coupled external clock at RT. When the oscillator is synchronized with the external clock, spread spectrum is disabled.

Pin Description (continued)

PIN	NAME	FUNCTION
11	GND	Signal Ground. GND is the current return path connection for the low-noise analog signals. Connect GND, LEDGND, and PGND at a single point.
12	IREF	LED Current Reference Input. Connect a resistor ($R_{IREF} = 49.9k\Omega$ or $45.2k\Omega$) from IREF to GND to set the current reference.
13	DIM	PWM Dimming Input. Apply a PWM signal to DIM for LED dimming control unless I ² C dimming is used. Connect DIM to V _{CC} if dimming control is not used (100% brightness). Connect DIM to GND if dimming is to be controlled through I ² C.
14	OUT6	LED String Cathode Connection 6. OUT6 is the open-drain output of the linear current sink that controls the current through the LED string connected to OUT6. OUT6 sinks up to 120mA.
15	OUT4	LED String Cathode Connection 4. OUT4 is the open-drain output of the linear current sink that controls the current through the LED string connected to OUT4. OUT4 sinks up to 120mA.
16	OUT2	LED String Cathode Connection 2. OUT2 is the open-drain output of the linear current sink that controls the current through the LED string connected to OUT2. OUT2 sinks up to 120mA.
17	FSEN	Fail-Safe Enable Pin. When FSEN is taken high, the boost converter is enabled and the outputs (OUT1–OUT6) are enabled at 100% duty cycle, independent of all register settings. Connect a resistor from FSEN to GND to set the LED current; FSEN sets both the LED current (when FSEN is active) and the I ² C address (see the MAX20446 FSEN Pin Function section). If the FSEN function is not needed, connect the pin directly to GND.
18	COMP	Switching-Converter Compensation Input. Connect the compensation network from COMP to GND for current-mode control (see the Feedback Compensation section for details).
19	CS	Current-Sense Input. CS is the current-sense input for the switching regulator. A sense resistor connected from the source of the external power MOSFET to PGND sets the switching current limit. A resistor connected between the source of the power MOSFET and CS sets the slope-compensation ramp rate (see the Slope Compensation and Current-Sense Resistor section).
20	BSTMON	Oversvoltage Threshold-Adjust Input. Connect a resistor-divider from the switching converter output to BSTMON and GND. The OVP comparator reference is internally set to 1.23V.
21	PGND	Power Ground. PGND is the switching-current return-path connection. Connect GND, LEDGND, and PGND at a single point.
22	NDRV	Switching nMOSFET Gate-Driver Output. Connect NDRV to the gate of the external switching-power MOSFET. Typically, a small resistor (1 Ω to 22 Ω) is inserted between the NDRV output and nMOSFET gate to decrease the slew rate of the gate driver and reduce the switching noise.
23	V _{CC}	5V Regulator Output. Bypass V _{CC} to GND with a minimum of 1 μ F ceramic capacitor as close as possible to the device.
24	EN	Enable Input. Connect EN to ground to shut down the device. Connect EN to logic-high or IN for normal operation. EN has an internal clamp at 3.9V. When EN is above this voltage, an input current of $(V_{EN} - 3.9V)/1.2M\Omega$ will flow.
—	EP	Exposed Pad. Connect EP to a large-area contiguous copper-ground plane for effective power dissipation. Do not use as the main IC ground connection. EP must be connected to GND.

Functional Diagram

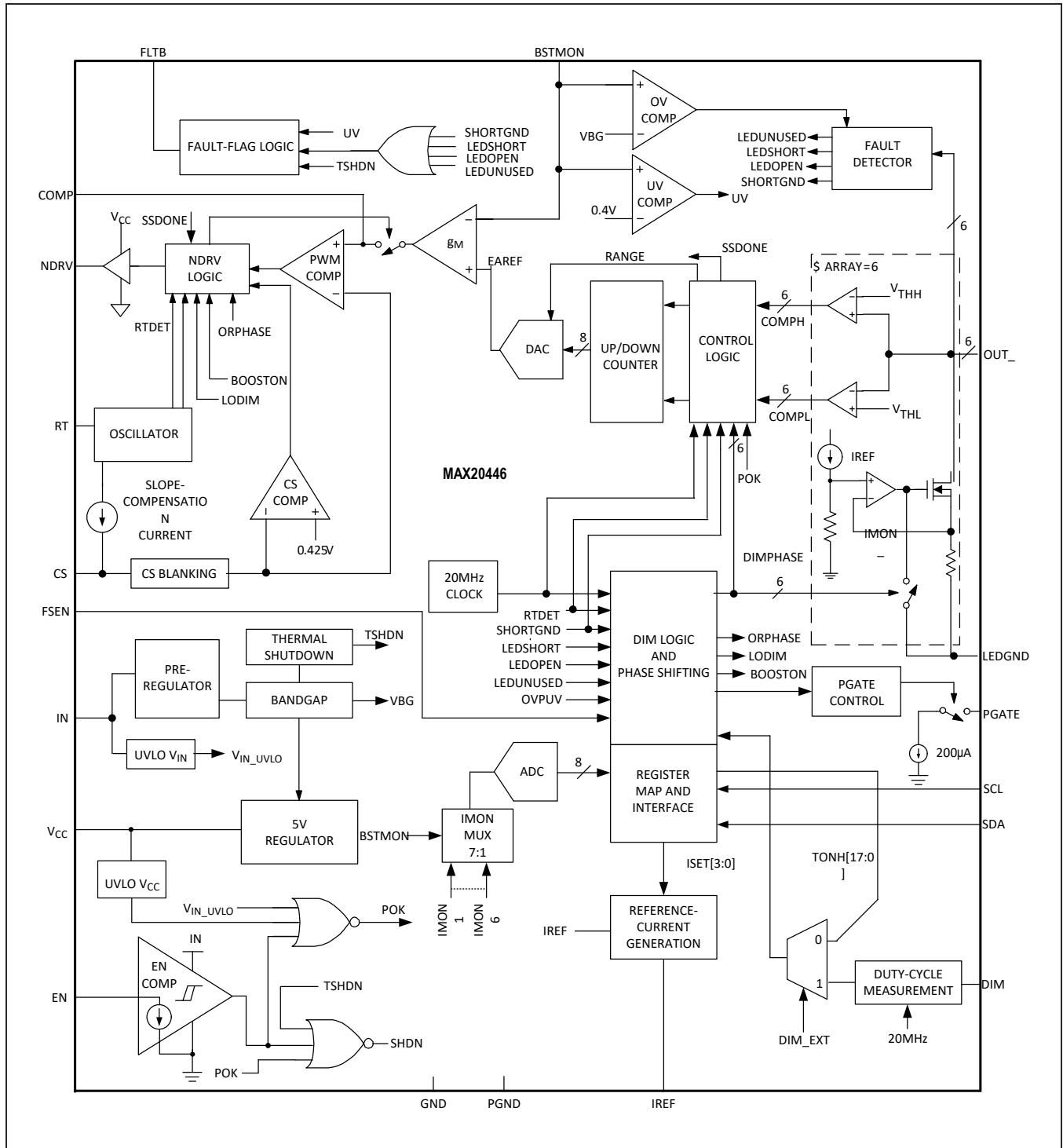

Detailed Description

The MAX20446 high-efficiency HB LED driver integrates all the necessary features to implement a high-performance backlight driver to power LEDs in medium-to-large-sized displays for automotive, as well as general applications. The device provides load-dump voltage protection up to 52V in automotive applications and incorporates three major blocks: a DC-DC controller with peak current-mode control to implement a boost or a SEPIC-type switched-mode power supply, a 6-channel LED driver with 45mA to 120mA constant-current sink capability per channel, and a control block with I²C interface.

Output Undervoltage Protection

At the end of the boost converter soft-start, an undervoltage threshold is activated on the output of the DC-DC converter, which is set at 430mV. If the BSTMON pin is below 430mV after the soft-start period of the DC-DC converter, the converter is turned off and the pMOSFET disconnects the input voltage from the LED driver. The FLTB pin is asserted low whenever undervoltage protection is activated. The ENA bit in the ISET (0x02) register must be toggled to start up again once the fault condition has been removed. Alternatively, the EN pin or power supply can be toggled.

Enable

The internal regulator and I²C interface are enabled when the EN pin is high. To shut down the device, drive EN low so the current consumption is reduced to 1μA (max).

Current-Mode DC-DC Controller

The device has a constant-frequency, current-mode controller designed to drive the LEDs in a boost, SEPIC, or coupled-inductor buck-boost configuration. The device features multiloop control to regulate the peak current in the inductor, as well as the voltage across the LED current sinks to minimize power dissipation.

The switching frequency can be programmed over the 400kHz to 2.2MHz range using a resistor connected from RT to GND.

Internal slope compensation is provided to compensate for subharmonic oscillations that occur at above 50% duty cycles in continuous-conduction mode.

The internal MOSFET is turned on at the beginning of every switching cycle. The inductor current ramps up linearly until it is turned off at the peak current level set by the feedback loop. The peak inductor current is sensed from the voltage across the current-sense resistor (R_{CS}), connected from the source of the external MOSFET to ground.

The device features leading-edge blanking to suppress the internal MOSFET switching noise. A PWM comparator compares the current-sense voltage, plus the slope-compensation signal with the output of the transconductance error amplifier. The controller turns off the MOSFET when the voltage at CS exceeds the error amplifier's output voltage, which is also the voltage on the COMP pin. This process repeats every switching cycle to achieve peak current-mode control.

In addition to the peak current-mode-control loop, the device has two other feedback loops for control. The converter output voltage is sensed through the BSTMON input, which goes to the inverting input of the error amplifier. The other feedback comes from the OUT_ current sinks. This loop controls the headroom of the current sinks to minimize total power dissipation while still ensuring accurate LED current matching. Each current sink has a window comparator with a low threshold of 0.78V and a high threshold of 1.03V. The outputs of these comparators control an up/down counter. The up/down counter is updated on every falling edge of the DIM input and drives an 8-bit DAC that sets the reference to the error amplifier. When dimming is set to 100%, the counter is updated at 10ms intervals.

8-Bit Digital-to-Analog Converter

The error amplifier's reference input is controlled with an 8-bit digital-to-analog converter (DAC). The DAC output ramps up slowly during startup to implement a soft-start function (see the [Startup Sequence](#) section). During normal operation, the DAC output range is limited to 0.6V to 1.25V. Because the DAC output is limited to no less than 0.6V during normal operation, the overvoltage threshold for the output should be set to a value less than twice the minimum LED forward voltage. The DAC LSB determines the minimum step-in output voltage according to Equation 1.

$$\text{Equation 1: } V_{\text{STEP_MIN}} = V_{\text{DAC_LSB}} \times A_{\text{OVP}}$$

where:

$V_{\text{STEP_MIN}}$ = Minimum output-voltage step

$V_{\text{DAC_LSB}}$ = DAC least significant bit size (2.5mV)

A_{OVP} = BSTMON resistor-divider gain ($1 + R_6/R_7$)

MAX20446 FSEN Pin Function

The FSEN (fail-safe enable) pin can be used to enable the device in situations where I²C control is temporarily impossible or the interface has stopped functioning. When FSEN is taken high, with the ENA bit high, the boost converter is turned on and the current sinks enabled. When FSEN returns low, the values programmed in the I²C registers are applied at the beginning of the next dimming cycle.

Table 1. FSEN Pin Function

FSEN RESISTOR VALUE (kΩ)	OUT_ CURRENT (mA)	I ² C ADDRESS
0	Fail-safe disabled	0x60
3.48	25	0x60
7.15	25	0x66
12	50	0x60
18.7	50	0x66
27.4	75	0x60
39	75	0x66
59	100	0x60
84.5	100	0x66

The OUT_ current ,when FSEN is high, is set by a resistor from FSEN to GND (see [Table 1](#)).

The resistor value is read at power-up; therefore, the set OUT_ current value and I²C address cannot be changed.

If FSEN is not used, connect the pin to GND, unless an I²C address other than 0x60 is desired.

PWM Dimming

Dimming can be performed either using an external PWM signal applied to the DIM pin or by programming the desired dimming level through I²C.

When using the DIM pin as an input, set the DIM_EXT bit in the IMODE register (0x03) to 1 (this is also the default value). The signal on the DIM pin is sampled with a 20MHz internal clock.

When using internal dimming, write up to 18 bits to the TON_[17:0] bits. The value to be written is calculated using the following formula: $TON = t_{ON}/50ns$, where t_{ON} is the desired on-time. If a value is written that corresponds to an on-time less than 500ns (< 0x09), the corresponding OUT_ stays on for 500ns. If the TON value exceeds the PWM period, the duty-cycle setting is 100%. To set zero current in any channel, write all the corresponding TON bits to 0.

The DIM input accepts a PWM signal greater than 100Hz to control the current and the luminous intensity of the LEDs. The DIM input detects the dimming frequency based on the first two pulses applied to the DIM input after EN goes high. The dimming frequency cannot be changed during normal operation. If a change of dimming frequency is desired, the EN input should be set low, and the DIM frequency changed; then, the EN signal can be

set high again. The DIM signal can be applied before or after the device is enabled, but the DIM signal needs to power on smoothly (no high-frequency pulses). If the DIM signal turn-on is inconsistent, then the DIM signal should be applied first, and once the DIM signal is stable, then the EN signal can be applied.

Hybrid Dimming

In hybrid dimming mode, the external LEDs are dimmed by first reducing their current as the dimming duty cycle decreases from 100% (see [Figure 1](#)). At the crossover level set by the HDIM[1:0] bits, dimming transitions to PWM dimming where the LED current is chopped. To select hybrid dimming, set the HDIM bit in the IMODE register and select the desired crossover level between analog and PWM dimming using the HDIM_THR[1:0] bits in the same register (see [Figure 1](#)). Depending on the DIM_EXT bit, the device then either:

- If DIM_EXT=1, measures the duty cycle on the DIM pin and translates it into a combined LED current value and PWM setting, or
- If DIM_EXT=0, takes the 18-bit TON_[17:0] value and translates it into a combined LED current value and PWM setting.

Note: When hybrid dimming is used with an internal dimming setting (e.g., DIM_EXT=0), only the value TON_[17:0] is used. It is not possible to have individual dimming settings for each of the channels in this mode, but the TON_ settings for all the channels must be nonzero.

In summary, there are four possible dimming modes:

- 1) External PWM dimming.
- 2) Internal PWM dimming, with the pulse width set through I²C and the PWM frequency generated internally.
- 3) External hybrid dimming, with a PWM signal applied to the DIM pin; the pulsed current on the OUT_ pins follows the DIM frequency.
- 4) Internal hybrid dimming, with the dimming ratio set through I²C and the PWM frequency generated internally.

[Figure 2](#) illustrates the difference between standard and hybrid dimming, with phase shifting enabled. Note that when dimming to 0%, it is necessary to reduce the dimming ratio from 100% in steps including at least one non-zero step below the hybrid dimming threshold. Alternatively, a channel can be disabled using the DIS[6:1] bits in the DISABLE (0x13) register.

Low-Dimming Mode

The device operation changes at very narrow dimming pulses to ensure a consistent dimming response of the LEDs. If the dimming on-time (either of the DIM input or of the value in the TON_ bits, depending on which is selected) is lower than 50µs (typ), the device enters low-dimming mode. In this state, the converter switches continuously and the LED short detection is disabled. When the DIM input is greater than 51µs (typ), the device goes back into

normal operation, enabling the short-LED detection and switching the power MOSFET only when the effective dimming signal is high. OUT_ current monitoring does not operate in low-dim mode, although the BSTMON voltage can still be measured.

When the device is used in I²C mode with internal dimming, some channels may be in low-dim mode while others may not. If any channel is in low-dim mode, the boost converter runs continuously.

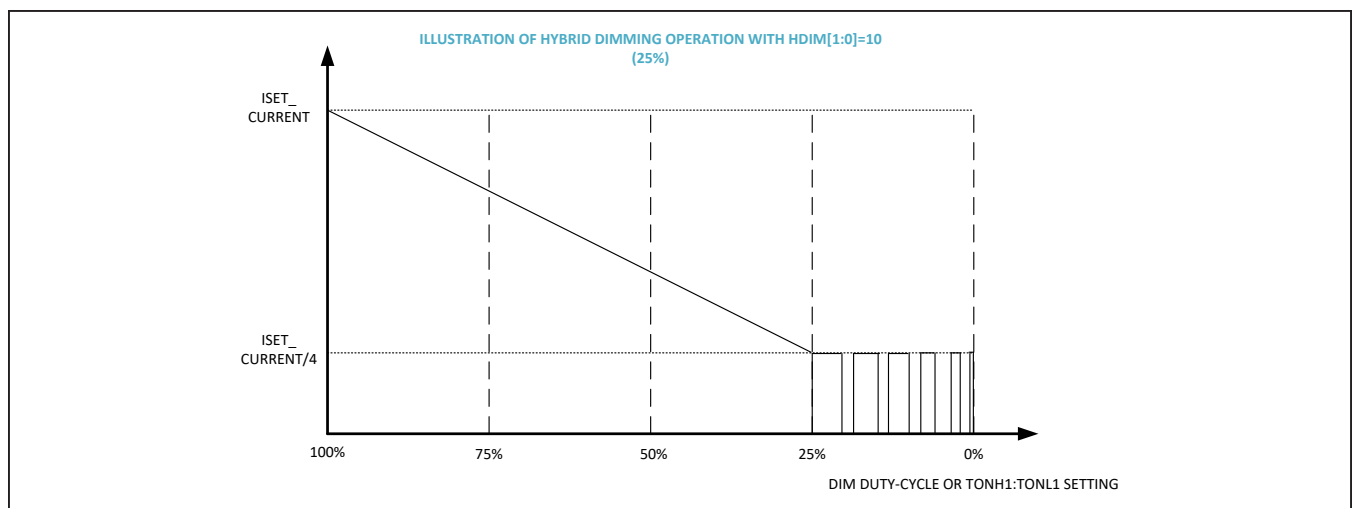

Figure 1. Hybrid Dimming Operation

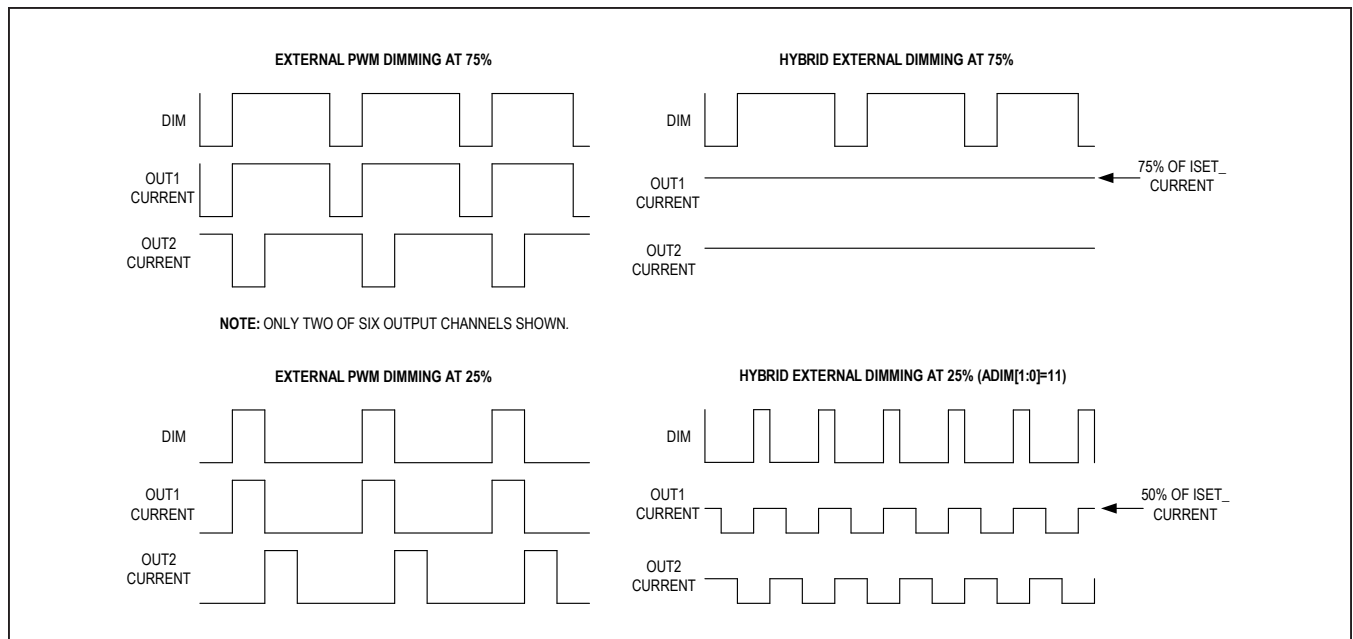

Figure 2. Hybrid Dimming Operation Modes

Phase-Shift Dimming

When the PSEN bit in the ISET register (0x02) is set, phase shifting of the LED strings is enabled. The device automatically sets the phase shift between strings to 60°, 72°, 90°, 120°, or 180° depending on the number of strings enabled.

Disabling Individual Strings on the MAX20446

To disable an unused LED string, connect the unused OUT_ to ground through a 12kΩ resistor, or set the corresponding DIS_ bit to 1 in the DISABLE (0x13) register before setting the ENA bit. During startup, the device sources 60μA (typ) current through the OUT_ pins and measures the corresponding voltage. For the string to be properly disabled, the OUT_ voltage should measure between 365mV and 1.15V during this check. 365mV is the maximum threshold for the OUT_ short-to-ground check and 1.15V is the minimum unused string-detection threshold.

Note: When disabling unused strings, start by disabling the highest numbered current sinks first (e.g., if two strings need to be disabled, disable OUT6 and OUT5. Do not disable any two strings at random). During normal operation, strings can be selectively turned off by changing the corresponding PWM setting to 0. This is only possible when internal dimming is used (not when using the DIM input pin).

Undervoltage Lockout

The device features two undervoltage lockouts (UVLOs) that monitor the input voltage at IN and the output of the internal LDO regulator at V_{CC}. The device turns on when EN is taken high if both IN and V_{CC} are higher than their respective UVLO thresholds.

Startup Sequence

When the EN pin is taken high (assuming the IN voltage is above its undervoltage-lockout value), the internal regulator and the interface are turned on and the device checks the OUT_ channels; if any of the OUT_ pins are detected as shorted to GND, the boost converter will not start (to avoid possible damage) and the corresponding OUTSG bit(s) are set. The device also detects and disconnects any unused current-sink channels that are connected to GND through a 12kΩ resistor. Alternatively, when using the I²C interface, individual channels can be disabled using the DIS[6:1] bits. The total duration of this phase of the startup is 2ms (max). After this phase, the I²C interface can be used and the device registers written. Finally, the ENA bit is set to 1 to enable the boost and subsequently the OUT_ current sinks. When the ENA bit is set high, the startup sequence occurs in three stages (see the [Stage 1](#), [Stage 2](#), and [Stage 3](#) sections).

Stage 1

Once the ENA bit is high, the controller begins the soft-start of the boost. First the driver of the external pMOSFET is turned on. A constant current of 200μA (typ) then flows into the PGATE pin of the device. The current flowing into resistor R3 (see the [Typical Application Circuit—Boost](#)) pulls down the gate of the external pMOSFET. This capacitor controls the turn-on time of the external pMOSFET.

After the external pMOSFET (Q2) is turned on and a 2ms timeout expires, stage 2 of the startup begins (see the [Stage 2](#) section).

Stage 2

After the checks in [Stage 1](#) have been performed, the converter starts switching and the output begins to ramp. The DAC reference to the error amplifier is stepped up 1 bit at a time until BSTMON reaches 600mV. This stage duration is fixed at approximately 50ms (typ). The BSTMON pin is then monitored, and if the voltage at the BSTMON pin is less than 430mV (typ), FLTB is asserted low, the power converter is turned off, the external pMOSFET is turned off, and they all stay off until the ENA bit is toggled (see the [Stage 3](#) section).

Stage 3

The third stage begins once [Stage 2](#) is complete and the DIM input goes high (with DIM_EXT=1), or the internal dimming is enabled by setting a PWM value greater than 0 on any of the channels. During [Stage 3](#), the output of the converter is adjusted until the minimum OUT_ voltage falls within 0.78V (typ) and 1.03V (typ) comparator limits. The output adjustment is again controlled by the DAC, which provides the reference for the error amplifier. The DAC output is updated on each rising edge of the DIM input pin (or internal dimming signal). If the DIM input (or the internal dimming signal when DIM_EXT=1) is at 100% duty cycle (DIM = high), the DAC output is updated once every 10ms.

The total soft-start time can be calculated using Equation 2.

Equation 2:

$$t_{SS} = 52\text{ms} + \frac{(V_{LED} + 0.91) - (0.6 \times A_{OVP})}{f_{DIM} \times 0.01 \times A_{OVP}}$$

where:

t_{SS} = Total soft-start time,

52ms = Fixed stage 1 + stage 2 duration,

V_{LED} = Total forward voltage of the LED strings,

0.91V = Midpoint of the window comparator,

f_{DIM} = Dimming frequency (use 100Hz for f_{DIM} when input duty cycle is 100%),

0.01V = 4 times the 2.5mV LSB of the DAC, and

A_{OVP} = Gain of the BSTMON resistor-divider or $1 + R_6/R_7$.

After the soft-start period, a fault is detected whenever the BSTMON pin falls below 430mV (typ). When this occurs, the power converter is latched off and PGATE goes high. Cycling the ENA bit, EN pin, or the supply is required to start up again once the fault condition has been removed.

Oscillator Frequency/External Synchronization

The internal oscillator frequency is programmable between 400kHz and 2.2MHz using a timing resistor (R_{RT}) connected from the RT pin to GND. Use Equation 3 to calculate the value of R_{RT} for the desired switching frequency (f_{SW}).

Equation 3:

$$R_{RT} = \frac{29260 + (2200 - f_{SW}) \times 0.81}{f_{SW}}$$

where f_{SW} is in kHz and R_{RT} is in k Ω .

Synchronize the oscillator with an external clock by AC-coupling the external clock to the RT input. The value of the capacitor used for AC-coupling is $C_{SYNC} = 10pF$ and the duty cycle of the external clock should be 50%.

Spread-Spectrum Mode

The device includes a spread-spectrum mode that reduces peak electromagnetic interference (EMI) at the switching frequency and its harmonics.

The spread spectrum uses a pseudorandom dithering technique where the switching frequency is varied in the range of 97% (or 94% when the SSL bit is 1) of the programmed switching frequency, to 103% (or 106% when the SSL bit is 1) of the programmed switching frequency set through the external resistor from RT to GND. When spread spectrum is used, the total energy at the fundamental and each harmonic is spread over a wider bandwidth, reducing the energy peak.

Spread spectrum is disabled if external synchronization is used. Optionally, spread spectrum can be disabled by setting the SS_OFF bit in the SETTING register to 1. The amount of spread spectrum can also be varied between $\pm 3\%$ and $\pm 6\%$ using the SSL bit in the same register.

5V LDO Regulator (V_{CC})

The internal LDO regulator converts the input voltage at IN to a 5V output voltage at V_{CC} . The LDO regulator supplies current to the internal control circuitry and the gate driver. Bypass V_{CC} to GND, with a minimum of 1 μF ceramic capacitor, placed as close as possible to the device.

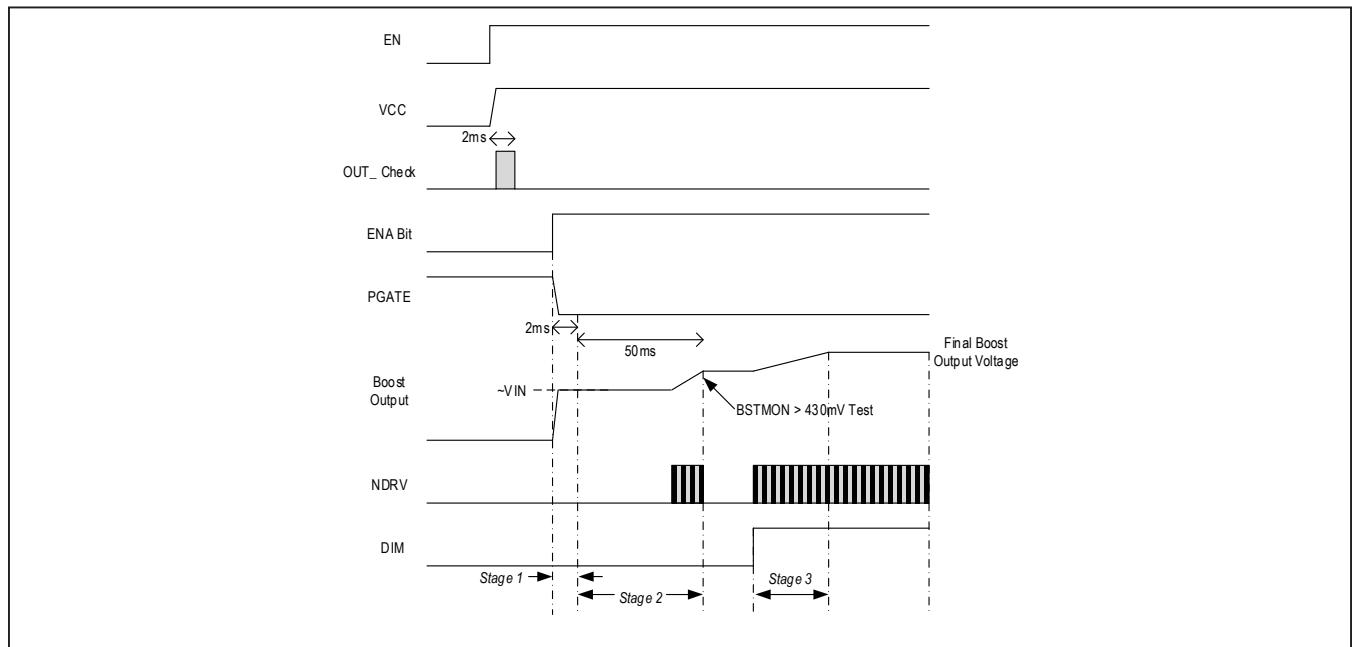

Figure 3. Boost Startup

LED Current Control

The full-scale sink current for the outputs (OUT1–OUT6) is set using the 4 bits (ISET[3:0]) in register 0x02. See the [ISET \(0x02\)](#) section to find the correct bit value for the desired current with R_{IREF} = 49.9kΩ. When PWM dimming is used, the current in the OUT_ channels switches between zero and the full-scale sink current at the set duty cycle.

The maximum LED current may be increased to 130mA by reducing the value of IREF resistor to 45.2kΩ. With this value of IREF resistor, the new ISET values are shown in [Table 2](#).

When hybrid dimming is used, the sink current in OUT1–OUT6 is reduced linearly from the full-scale value until the level set by HDIM[1:0] is reached; dimming at lower levels is then accomplished using PWM (see [Figure 1](#)).

Fault Protection

Fault protection in the device includes cycle-by-cycle current limiting using the PWM controller, DC-DC converter output undervoltage protection, output overvoltage protection, open-LED detection, short-LED detection and protection, and overtemperature shutdown. An open-drain fault flag output (FLT_B) goes low when an open-LED string is detected, a short-LED string is detected, an output undervoltage, or during thermal shutdown. FLT_B is cleared when the fault condition is removed during thermal shutdown and shorted LEDs. FLT_B is latched low for an open LED and can be reset by cycling power or toggling the EN pin or ENA bit in register 0x02. The thermal-shutdown threshold is +165°C and has +15°C hysteresis.

Open-LED Management and Overvoltage Protection

On power-up, the device performs a soft-start of the boost converter. After soft-start, the device detects open LED and disconnects any strings with an open LED from the internal minimum OUT_ voltage detector. This keeps the DC-DC converter output voltage within safe limits and maintains high efficiency. The current in strings that have been detected open is not measured and reads as zero.

Table 2. ISET Currents with 45.2kΩ IREF Resistor

ISET[3:0]	NOMINAL OUT_ CURRENT (mA)
0000	49
0001	54
0010	60
0011	65
0100	70
0101	76
0110	81
0111	87
1000	92
1001	97
1010	103
1011	108
1100	114
1101	119
1110	125
1111	130

During normal operation, the DC-DC converter output-regulation loop uses the minimum OUT_ voltage as the feedback input. If any LED string is open, the voltage at the opened OUT_ goes to V_{LEDGND}. The DC-DC converter output voltage then increases to the overvoltage-protection threshold set by the voltage-divider network connected between the converter output, the BSTMON input, and GND. The overvoltage-protection threshold at the DC-DC converter output is determined using Equation 4.

Equation 4:

$$V_{\text{OUT_BSTMON}} = 1.23 \times \left(1 + \frac{R6}{R7}\right)$$

where 1.23 (typ) is the overvoltage threshold on BSTMON (see the [Functional Diagram](#)). Select V_{OUT_BSTMON} according to Equation 5.

Equation 5:

$$1.1 \times (V_{LED_MAX} + 1.1) < V_{OUT_BSTMON} < 2 \times (V_{LED_MIN} + 0.7)$$

where:

V_{LED_MAX} = Maximum expected LED string voltage, and
 V_{LED_MIN} = Minimum expected LED string voltage.
 Select R6 and R7 such that the voltage at OUT_ does not exceed the [Absolute Maximum Ratings](#). As soon as the DC-DC converter output reaches the overvoltage-protection threshold, the internal MOSFET is switched off.

The overvoltage threshold should be set less than twice the minimum LED voltage to ensure proper operation; the BSTMON minimum regulation point is 600mV (typ). Connect a 12kΩ resistor between OUT_ and LEDGND for each unused channel to avoid overvoltage triggering at startup. When an open-LED overvoltage condition occurs, FLT_B is latched low. Any current-sink output with $V_{OUT_} < 300\text{mV}$ (typ) is disconnected from the minimum voltage detector.

Short-LED Detection

The device checks for shorted LEDs before the current in any channel is turned on. A shorted LED is detected at OUT_ if the condition in Equation 6 is met.

Equation 6:

$$V_{OUT_} > RS_{DT}$$

where:

RS_{DT} = Programmable short-LED detection threshold set by the SLDET[2:0] bits in the SETTING (0x12) register.

If a short is detected on any of the strings, the affected LED strings are disconnected and the FLT_B output flag asserts until the device detects that the shorts are removed. Disable short-LED detection by setting SLDET[2:0] to 0. Short-LED detection is disabled in low-dimming mode. In external dimming mode with the DIM input connected continuously high, the OUT_ pins are periodically scanned to detect shorted LEDs. The scan frequency is 100Hz.

Similarly, when DIM_EXT=0 and internal dimming is being used, shorted LEDs are still detected by periodically scanning the OUT_ states at 100Hz.

Thermal Warning/Shutdown

The device includes thermal protection that operates at a temperature of 165°C. When the thermal-shutdown temperature is reached, the device is immediately disabled and begins to cool. When the junction temperature falls by 15°C, the device is re-enabled with the same settings as before (the boost converter performs a soft-start). When a thermal shutdown occurs, the FLT_B pin goes low and the OT bit, if read through I²C, is set to 1.

A thermal-warning bit (OTW) implemented in register 0x1F, indicates when the junction temperature has exceeded 125°C. The OTW_MASK bit in register 0x1E is used to control whether or not an active OTW bit causes the FLT_B pin to low.

Analog-to-Digital Converter

The analog-to-digital converter (ADC) is used to measure the current in each of the strings and the voltage on the BSTMON pin. A conversion cycle is started by setting the CONVERT bit to 1. At the end of the cycle, the CONVERT bit is reset to 0 to indicate a complete cycle and the IOUT1–OUT6 and BSTMON registers contain the updated values. The full-scale value of the current measurement is 127.5mA or 140.8mA with $R_{IREF} = 45.2\text{k}\Omega$. Values higher than these read as full-scale or 0xFF. Current measurements are not performed on channels that are in low-dim mode; before performing a conversion, this can be checked by reading the LoDIM_ bits. If a conversion is attempted on a channel that is in low-dim mode, the current value returned will be 0x00. The duration of a complete conversion depends on whether or not phase shifting is enabled. With phase shifting enabled, a complete conversion can take up to two dimming cycles, worst case. With phase shifting disabled, one dimming cycle is the worst-case latency (the conversion is initiated at the beginning of a DIM cycle and is concluded < 50μs later).

Register Map

ADDRESS	NAME	MSB							LSB
I ² C									
0x00	Dev_ID	Device_ID[7:0]							
0x01	Rev_ID	–	–	LoDIM6	LoDIM5	Revision_ID[3:0]			
0x02	ISET	–	CON- VERT	ENA	PSEN	ISET[3:0]			
0x03	IMODE	LoDIM4	LoDIM3	LoDIM2	LoDIM1	DIM_EXT	HDIM	HDIM_THR[1:0]	
0x04	TONH1	PWM1[17:10]							
0x05	TONL1	PWM1[9:2]							
0x06	TONH2	PWM2[17:10]							
0x07	TONL2	PWM2[9:2]							
0x08	TONH3	PWM3[17:10]							
0x09	TONL3	PWM3[9:2]							
0x0A	TONH4	PWM4[17:10]							
0x0B	TONL4	PWM4[9:2]							
0x0C	TON1-4LSB	PWM4[1:0]		PWM3[1:0]		PWM2[1:0]		PWM1[1:0]	
0x0D	TONH5	PWM5[17:10]							
0x0E	TONL5	PWM5[9:2]							
0x0F	TONH6	PWM6[17:10]							
0x10	TONL6	PWM6[9:2]							
0x11	TON5-6LSB	–	–	–	–	PWM6[1:0]		PWM5[1:0]	
0x12	SETTING	–	FPWM[2:0]			SS_OFF	SSL	SLDET[1:0]	
0x13	DISABLE	–	–	DIS6	DIS5	DIS4	DIS3	DIS2	DIS1
0x14	BSTMON	VMON[7:0]							
0x15	IOUT1	IOUT1[7:0]							
0x16	IOUT2	IOUT2[7:0]							
0x17	IOUT3	IOUT3[7:0]							
0x18	IOUT4	IOUT4[7:0]							
0x19	IOUT5	IOUT5[7:0]							
0x1A	IOUT6	IOUT6[7:0]							
0x1B	OPEN	–	–	OUT6O	OUT5O	OUT4O	OUT3O	OUT2O	OUT1O
0x1C	SHORTGND	–	–	OUT6SG	OUT5SG	OUT4SG	OUT3SG	OUT2SG	OUT1SG
0x1D	SHORTED LED	–	–	OUT6SL	OUT5SL	OUT4SL	OUT3SL	OUT2SL	OUT1SL
0x1E	MASK	–	–	–	BSTUV- MASK	OMASK	SG- MASK	OTWMASK	SLMASK
0x1F	DIAG	–	–	IREFOOR	BSTUV	BSTOV	HW_ RST	OTW	OT

Register Details**Dev_ID (0x00)**

BIT	7	6	5	4	3	2	1	0
Field	Device_ID[7:0]							
Reset								
Access Type	Read Only							

BITFIELD	BITS	DESCRIPTION	DECODE
Device_ID	7:0		Device ID, reads 0x46 for MAX20446.

Rev_ID (0x01)

BIT	7	6	5	4	3	2	1	0
Field	–	–	LoDIM6	LoDIM5	Revision_ID[3:0]			
Reset	–	–						
Access Type	–	–	Read Only	Read Only	Read Only			

BITFIELD	BITS	DESCRIPTION
LoDIM6	5	When 1, indicates that channel 6 is in low-dim mode.
LoDIM5	4	When 1, indicates that channel 5 is in low-dim mode.
Revision_ID	3:0	Device revision ID

ISET (0x02)

Boost slew rate and output-current setting.

BIT	7	6	5	4	3	2	1	0
Field	–	CONVERT	ENA	PSEN	ISET[3:0]			
Reset	–	0b0	0b0	0b1	0b1011			
Access Type	–	Write, Read	Write, Read	Write, Read	Write, Read			

BITFIELD	BITS	DESCRIPTION
CONVERT	6	Write a 1 to this bit to start a conversion cycle of the ADC. When the cycle is finished this bit is automatically reset to indicate that data is ready.
ENA	5	ENA
		0
		1
PSEN	4	When 0, phase-shifting is disabled. Default value is 1.
ISET	3:0	LED Current Setting:
		ISET3 ISET2 ISET1 ISET0 CURRENT SETTING
		0 0 0 0 45mA
		0 0 0 1 50mA
		0 0 1 0 55mA
		0 0 1 1 60mA
		0 1 0 0 65mA
		0 1 0 1 70mA
		0 1 1 0 75mA
		0 1 1 1 80mA
		1 0 0 0 85mA
		1 0 0 1 90mA
		1 0 1 0 95mA
		1 0 1 1 100mA*
		1 1 0 0 105mA
		1 1 0 1 110mA
		1 1 1 0 115mA
1 1 1 1 120mA		
		<i>*Default value.</i>

IMODE (0x03)

Phase-shift enable, individual string disable, analog dimming enable, and setting of crossover between analog/digital dimming (50%, 25%, 12.5%, 6.25%).

BIT	7	6	5	4	3	2	1	0
Field	LoDIM4	LoDIM3	LoDIM2	LoDIM1	DIM_EXT	HDIM	HDIM_THR[1:0]	
Reset	0x0	0x0	0x0	0x0	0b1	0b0	0b00	
Access Type	Read Only	Read Only	Read Only	Read Only	Write, Read	Write, Read	Write, Read	

BITFIELD	BITS	DESCRIPTION	DECODE	
LoDIM4	7	When 1, indicates that channel 4 is in low-dim mode.		
LoDIM3	6	When 1, indicates that channel 3 is in low-dim mode.		
LoDIM2	5	When 1, indicates that channel 2 is in low-dim mode.		
LoDIM1	4	When 1, indicates that channel 1 is in low-dim mode.		
DIM_EXT	3	When 1, dimming through the DIM pin is enabled. When 0, dimming is controlled using the PWM_ registers. Default value is 1.		
HDIM	2	When 1, hybrid dimming is enabled. Default value 0.	When 1, hybrid dimming is enabled. Default value is 0.	
HDIM_THR	1:0	Set hybrid dimming threshold. Default value is 6.25% (00).	HDIM_THR	Threshold (%)
			00	6.25
			01	12.5
			10	25
			11	50

TONH1 (0x04)

On-time setting for channel 1 with 50ns resolution, high byte.

BIT	7	6	5	4	3	2	1	0
Field	PWM1[17:10]							
Reset	0b11111111							
Access Type	Write, Read							

BITFIELD	BITS	DESCRIPTION
PWM1	7:0	High byte of 18-bit PWM setting for channel 1.

TONL1 (0x05)

On-time setting for channel 1 with 50ns resolution, low byte.

BIT	7	6	5	4	3	2	1	0
Field	PWM1[9:2]							
Reset	0b11111111							
Access Type	Write, Read							

BITFIELD	BITS	DESCRIPTION
PWM1	7:0	Middle byte of 18-bit PWM setting for channel 1.

TONH2 (0x06)

On-time setting for channel 2 with 50ns resolution, high byte.

BIT	7	6	5	4	3	2	1	0
Field	PWM2[17:10]							
Reset	0b11111111							
Access Type	Write, Read							

BITFIELD	BITS	DESCRIPTION
PWM2	7:0	High byte of 18-bit PWM setting for channel 2.

TONL2 (0x07)

On-time setting for channel 2 with 50ns resolution, low byte.

BIT	7	6	5	4	3	2	1	0
Field	PWM2[9:2]							
Reset	0b11111111							
Access Type	Write, Read							

BITFIELD	BITS	DESCRIPTION
PWM2	7:0	Middle byte of 18-bit PWM setting for channel 2.

TONH3 (0x08)

On-time setting for channel 3 with 50ns resolution, high byte.

BIT	7	6	5	4	3	2	1	0
Field	PWM3[17:10]							
Reset	0b11111111							
Access Type	Write, Read							

BITFIELD	BITS	DESCRIPTION
PWM3	7:0	High byte of 18-bit PWM setting for channel 3.

TONL3 (0x09)

On-time setting for channel 3 with 50ns resolution, low byte.

BIT	7	6	5	4	3	2	1	0
Field	PWM3[9:2]							
Reset	0b11111111							
Access Type	Write, Read							

BITFIELD	BITS	DESCRIPTION
PWM3	7:0	Middle byte of 18-bit PWM setting for channel 3.

TONH4 (0x0A)

On-time setting for channel 4 with 50ns resolution, high byte.

BIT	7	6	5	4	3	2	1	0
Field	PWM4[17:10]							
Reset	0b11111111							
Access Type	Write, Read							

BITFIELD	BITS	DESCRIPTION
PWM4	7:0	High byte of 18-bit PWM setting for channel 4.

TONL4 (0x0B)

On-time setting for channel 4 with 50ns resolution, low byte.

BIT	7	6	5	4	3	2	1	0
Field	PWM4[9:2]							
Reset	0b11111111							
Access Type	Write, Read							

BITFIELD	BITS	DESCRIPTION
PWM4	7:0	Middle byte of 18-bit PWM setting for channel 4.

TON1-4LSB (0x0C)

Least significant bits of on-time setting for channels 1–4.

BIT	7	6	5	4	3	2	1	0
Field	PWM4[1:0]		PWM3[1:0]		PWM2[1:0]		PWM1[1:0]	
Reset	0b11		0b11		0b11		0b11	
Access Type	Write, Read		Write, Read		Write, Read		Write, Read	

BITFIELD	BITS	DESCRIPTION
PWM4	7:6	2 least significant bits of 18-bit PWM setting for channel 4.
PWM3	5:4	2 least significant bits of 18-bit PWM setting for channel 3.
PWM2	3:2	2 least significant bits of 18-bit PWM setting for channel 2.
PWM1	1:0	2 least significant bits of 18-bit PWM setting for channel 1.

TONH5 (0x0D)

On-time setting for channel 5 with 50ns resolution, high byte.

BIT	7	6	5	4	3	2	1	0
Field	PWM5[17:10]							
Reset	0xFF							
Access Type	Write, Read							

BITFIELD	BITS	DESCRIPTION
PWM5	7:0	High byte of 18-bit PWM setting for channel 5.

TONL5 (0x0E)

On-time setting for channel 5 with 50ns resolution, low byte.

BIT	7	6	5	4	3	2	1	0
Field	PWM5[9:2]							
Reset	0b11111111							
Access Type	Write, Read							

BITFIELD	BITS	DESCRIPTION
PWM5	7:0	Middle byte of 18-bit PWM setting for channel 5.

TONH6 (0x0F)

On-time setting for channel 6 with 50ns resolution, high byte.

BIT	7	6	5	4	3	2	1	0
Field	PWM6[17:10]							
Reset	0b11111111							
Access Type	Write, Read							

BITFIELD	BITS	DESCRIPTION
PWM6	7:0	High byte of 18-bit PWM setting for channel 6.

TONL6 (0x10)

On-time setting for channel 6 with 50ns resolution, low byte.

BIT	7	6	5	4	3	2	1	0
Field	PWM6[9:2]							
Reset	0b11111111							
Access Type	Write, Read							

BITFIELD	BITS	DESCRIPTION
PWM6	7:0	Middle byte of 18-bit PWM setting for channel 6.

TON5-6LSB (0x11)

Least significant bits of on-time setting for channels 5 and 6.

BIT	7	6	5	4	3	2	1	0
Field	–	–	–	–	PWM6[1:0]		PWM5[1:0]	
Reset	–	–	–	–	0b11		0b11	
Access Type	–	–	–	–	Write, Read		Write, Read	

BITFIELD	BITS	DESCRIPTION
PWM6	3:2	2 least significant bits of 18-bit PWM setting for channel 6.
PWM5	1:0	2 least significant bits of 18-bit PWM setting for channel 5.

SETTING (0x12)

External/internal dimming, DIM-frequency level for shorted-LED detection.

BIT	7	6	5	4	3	2	1	0
Field	–	FPWM[2:0]			SS_OFF	SSL	SLDET[1:0]	
Reset	–	0b001			0b0	0b0	000	
Access Type	–	Write, Read			Write, Read	Write, Read	Write, Read	

BITFIELD	BITS	DESCRIPTION																																				
FPWM	6:4	These bits set the PWM frequency in internal PWM mode. When an external DIM signal is used, these bits set the fault-sampling frequency at 100% duty cycle.																																				
		<table border="1"> <thead> <tr> <th>FPWM2</th> <th>FPWM1</th> <th>FPWM0</th> <th>PWM FREQUENCY (Hz)</th> </tr> </thead> <tbody> <tr> <td>0</td> <td>0</td> <td>0</td> <td>153</td> </tr> <tr> <td>0</td> <td>0</td> <td>1</td> <td>203*</td> </tr> <tr> <td>0</td> <td>1</td> <td>0</td> <td>305</td> </tr> <tr> <td>0</td> <td>1</td> <td>1</td> <td>610</td> </tr> <tr> <td>1</td> <td>0</td> <td>0</td> <td>980</td> </tr> <tr> <td>1</td> <td>0</td> <td>1</td> <td>1220</td> </tr> <tr> <td>1</td> <td>1</td> <td>0</td> <td>1401</td> </tr> <tr> <td>1</td> <td>1</td> <td>1</td> <td>1634</td> </tr> </tbody> </table>	FPWM2	FPWM1	FPWM0	PWM FREQUENCY (Hz)	0	0	0	153	0	0	1	203*	0	1	0	305	0	1	1	610	1	0	0	980	1	0	1	1220	1	1	0	1401	1	1	1	1634
		FPWM2	FPWM1	FPWM0	PWM FREQUENCY (Hz)																																	
		0	0	0	153																																	
		0	0	1	203*																																	
		0	1	0	305																																	
		0	1	1	610																																	
		1	0	0	980																																	
		1	0	1	1220																																	
1	1	0	1401																																			
1	1	1	1634																																			
SS_OFF	3	When 1 spread-spectrum switching is disabled. Default value 0.																																				
SSL	2	When spread-spectrum is enabled the SSL bit chooses the amount of spread: when 0 the spread is nominally +/-6%, when 1 +/-3%.																																				
SLDET	1:0	Shorted-LED Threshold Setting:																																				
		<table border="1"> <thead> <tr> <th>SLDET1</th> <th>SLDET0</th> <th>SETTING</th> </tr> </thead> <tbody> <tr> <td>0</td> <td>0</td> <td>Disabled</td> </tr> <tr> <td>0</td> <td>1</td> <td>3V</td> </tr> <tr> <td>1</td> <td>0</td> <td>6V</td> </tr> <tr> <td>1</td> <td>1</td> <td>8V</td> </tr> </tbody> </table>	SLDET1	SLDET0	SETTING	0	0	Disabled	0	1	3V	1	0	6V	1	1	8V																					
		SLDET1	SLDET0	SETTING																																		
		0	0	Disabled																																		
		0	1	3V																																		
1	0	6V																																				
1	1	8V																																				

DISABLE (0x13)

BIT	7	6	5	4	3	2	1	0
Field	–	–	DIS6	DIS5	DIS4	DIS3	DIS2	DIS1
Reset	–	–	0b0	0b0	0b0	0b0	0b0	0b0
Access Type	–	–	Write, Read	Write, Read	Write, Read	Write, Read	Write, Read	Write, Read

BITFIELD	BITS	DESCRIPTION
DIS6	5	Set this bit to 1 to disable OUT6. This must be done before ENA is written to 1.
DIS5	4	Set this bit to 1 to disable OUT5. This must be done before ENA is written to 1.
DIS4	3	Set this bit to 1 to disable OUT4. This must be done before ENA is written to 1.
DIS3	2	Set this bit to 1 to disable OUT3. This must be done before ENA is written to 1.
DIS2	1	Set this bit to 1 to disable OUT2. This must be done before ENA is written to 1.
DIS1	0	Set this bit to 1 to disable OUT1. This must be done before ENA is written to 1.

BSTMON (0x14)

BSTMON pin voltage readback.

BIT	7	6	5	4	3	2	1	0
Field	VMON[7:0]							
Reset	0b00000000							
Access Type	Read Only							

BITFIELD	BITS	DESCRIPTION
VMON	7:0	Voltage on BSTMON. Full-scale = 2.5V., 1 LSB = 5.1mV.

IOUT1 (0x15)

IOUT1 current readback.

BIT	7	6	5	4	3	2	1	0
Field	IOUT1[7:0]							
Reset	0b00000000							
Access Type	Read Only							

BITFIELD	BITS	DESCRIPTION	
IOUT1	7:0	Output Current Measurement (IOUT1):	
		READOUT	CURRENT (mA)
		0x00	0
		0x01	0.5
	
		0xFE	127
0xFF	127.5		

IOUT2 (0x16)

IOUT2 current readback.

BIT	7	6	5	4	3	2	1	0
Field	IOUT2[7:0]							
Reset	0b00000000							
Access Type	Read Only							

BITFIELD	BITS	DESCRIPTION
IOUT2	7:0	See the IOUT1 table.

OUT3 (0x17)

OUT3 current readback.

BIT	7	6	5	4	3	2	1	0
Field	IOUT3[7:0]							
Reset	0b00000000							
Access Type	Read Only							

BITFIELD	BITS	DESCRIPTION
IOUT3	7:0	See the IOUT1 table.

IOUT4 (0x18)

IOUT4 current readback.

BIT	7	6	5	4	3	2	1	0
Field	IOUT4[7:0]							
Reset	0b00000000							
Access Type	Read Only							

BITFIELD	BITS	DESCRIPTION
IOUT4	7:0	See the IOUT1 table.

IOUT5 (0x19)

IOUT5 current readback.

BIT	7	6	5	4	3	2	1	0
Field	IOUT5[7:0]							
Reset	0b00000000							
Access Type	Read Only							

BITFIELD	BITS	DESCRIPTION
IOUT5	7:0	See the IOUT1 table.

IOUT6 (0x1A)

OUT6 current readback.

BIT	7	6	5	4	3	2	1	0
Field	IOUT6[7:0]							
Reset	0b00000000							
Access Type	Read Only							

BITFIELD	BITS	DESCRIPTION
IOUT6	7:0	See the IOUT1 table.

OPEN (0x1B)

Short-to-GND and open diagnostics.

BIT	7	6	5	4	3	2	1	0
Field	–	–	OUT6O	OUT5O	OUT4O	OUT3O	OUT2O	OUT1O
Reset	–	–	0x0	0b0	0b0	0b0	0b0	0b0
Access Type	–	–	Read Only	Read Only	Read Only	Read Only	Read Only	Read Only

BITFIELD	BITS	DESCRIPTION
OUT6O	5	If 1, an open has been detected on channel 6.
OUT5O	4	If 1, an open has been detected on channel 5.
OUT4O	3	If 1, an open has been detected on channel 4.
OUT3O	2	If 1, an open has been detected on channel 3.
OUT2O	1	If 1, an open has been detected on channel 2.
OUT1O	0	If 1, an open has been detected on channel 1.

SHORTGND (0x1C)

BIT	7	6	5	4	3	2	1	0
Field	–	–	OUT6SG	OUT5SG	OUT4SG	OUT3SG	OUT2SG	OUT1SG
Reset	–	–	0b0	0b0	0b0	0b0	0b0	0b0
Access Type	–	–	Read Only	Read Only	Read Only	Read Only	Read Only	Read Only

BITFIELD	BITS	DESCRIPTION
OUT6SG	5	If 1, a short-to-ground has been detected on channel 6 at startup.
OUT5SG	4	If 1, a short-to-ground has been detected on channel 5 at startup.
OUT4SG	3	If 1, a short-to-ground has been detected on channel 4 at startup.
OUT3SG	2	If 1, a short-to-ground has been detected on channel 3 at startup.
OUT2SG	1	If 1, a short-to-ground has been detected on channel 2 at startup.
OUT1SG	0	If 1, a short-to-ground has been detected on channel 1 at startup.

SHORTED LED (0x1D)

Shorted-LED diagnostics.

BIT	7	6	5	4	3	2	1	0
Field	–	–	OUT6SL	OUT5SL	OUT4SL	OUT3SL	OUT2SL	OUT1SL
Reset	–	–	0b0	0b0	0b0	0b0	0b0	0b0
Access Type	–	–	Read Only	Read Only	Read Only	Read Only	Read Only	Read Only

BITFIELD	BITS	DESCRIPTION
OUT6SL	5	If 1, a shorted-LED condition has been detected on channel 6.
OUT5SL	4	If 1, a shorted-LED condition has been detected on channel 5.
OUT4SL	3	If 1, a shorted-LED condition has been detected on channel 4.
OUT3SL	2	If 1, a shorted-LED condition has been detected on channel 3.
OUT2SL	1	If 1, a shorted-LED condition has been detected on channel 2.
OUT1SL	0	If 1, a shorted-LED condition has been detected on channel 1.

MASK (0x1E)

Mask register for FLTB pin.

BIT	7	6	5	4	3	2	1	0
Field	–	–	–	BSTUVMASK	OMASK	SGMASK	OTWMASK	SLMASK
Reset	–	–	–	0b0	0b0	0b0	0b0	0b0
Access Type	–	–	–	Write, Read	Write, Read	Write, Read	Write, Read	Write, Read

BITFIELD	BITS	DESCRIPTION
BSTUVMASK	4	When 1, a boost fault (undervoltage or overvoltage) does not cause the FLTB pin to assert low.
OMASK	3	When 1, an open-LED fault does not cause the FLTB pin to assert low.
SGMASK	2	When 1, a short-to-ground LED fault does not cause the FLTB pin to assert low.
OTWMASK	1	When 1, an overtemperature warning does not cause the FLTB pin to assert low.
SLMASK	0	When 1, a shorted-LED fault does not cause the FLTB pin to assert low.

DIAG (0x1F)

Boost state, overtemperature warning/shutdown.

BIT	7	6	5	4	3	2	1	0
Field	–	–	IREFOOR	BSTUV	BSTOV	HW_RST	OTW	OT
Reset	–	–	0b0	0b0	0b0	0b1	0b0	0b0
Access Type	–	–	Read Only	Read Only	Read Only	Read Only	Read Only	Read Only

BITFIELD	BITS	DESCRIPTION
IREFOOR	5	When 1, this bit indicates that the IREF current is out of range. This is probably due to an incorrect resistor value on IREF. In this condition, the IC stops operation.
BSTUV	4	If 1, an undervoltage has been detected on the boost output and the boost was disabled.
BSTOV	3	If 1, the boost converter is at its overvoltage limit.
HW_RST	2	If 1, the device has just emerged from a hardware reset (power-up). This bit is reset after the first read from this register.
OTW	1	If 1, the junction temperature of the device is over 125°C.
OT	0	If 1, the junction temperature of the device exceeded 165°C and the device was shut down.

Applications Information

DC-DC Converter

Three different converter topologies are possible with the DC-DC converter in the MAX20446, which have the ground-referenced outputs necessary to use the constant-current sink drivers. If the LED string forward voltage is always greater than the input supply voltage range, use the boost converter topology. If the LED string forward voltage falls within the supply voltage range, use a buck-boost converter topology. The possible buck-boost topologies are SEPIC or a coupled-inductor buck-boost topology. The latter is basically a flyback converter with 1:1 turns ratio. 1:1-coupled inductors are available with tight coupling suitable for this application.

The boost-converter topology provides the highest efficiency among the above-mentioned topologies. The coupled-inductor topology has the advantage of not using a coupling capacitor, but does require tightly coupled windings to avoid additional snubber components. The SEPIC configuration requires two inductors (or a coupled inductor) and a coupling capacitor. Furthermore, the feed-back-loop compensation for SEPIC becomes complex if the coupling capacitor is not large enough.

Power-Circuit Design

First select a converter topology based on the factors listed in the [DC-DC Converter](#) section. Determine the required input supply voltage range, the maximum voltage needed to drive the LED strings, including the minimum 0.85V across the constant LED current sink (V_{LED}), and the total output current needed to drive the LED strings (I_{LED}), as shown in Equation 7.

Equation 7:

$$I_{LED} = I_{STRING} \times N_{STRING}$$

where I_{STRING} is the current per string and N_{STRING} is the number of strings used.

Next, calculate the maximum duty cycle (D_{MAX}) using Equations 8 and 9.

Equation 8 (for boost configuration):

$$D_{MAX} = \frac{(V_{LED} + V_{D1} - V_{IN_MIN})}{(V_{LED} + V_{D1} - V_{DS} - 0.3)}$$

Equation 9 (for SEPIC and coupled-inductor buck-boost configurations):

$$D_{MAX} = \frac{V_{LED} + V_{D1}}{(V_{IN_MIN} - V_{DS} - 0.3 + V_{LED} + V_{D1})}$$

where:

- V_{D1} = Forward drop of the rectifier diode in volts (approximately 0.6V),
- V_{IN_MIN} = Minimum input supply voltage, and
- V_{DS} = Drain-to-source voltage of the internal MOSFET when it is on.

Select the switching frequency (f_{SW}) depending on the space, noise, and efficiency constraints.

Boost and Coupled-Inductor Configurations

In all three converter configurations, the average inductor current varies with the line voltage; the maximum average current occurs at the lowest line voltage. For the boost converter, the average inductor current is equal to the input current. Select the maximum peak-to-peak ripple on the inductor current (ΔI_L). The recommended maximum peak-to-peak ripple is 60% of the average inductor current, but lower and higher values for ripple are also acceptable. Use the following equations (Equations 9, 10, and 11) to calculate the maximum average inductor current (I_{L_AVG}) and peak inductor current (I_{L_P}) in amperes (Equation 9).

Equation 9:

$$I_{L_AVG} = \frac{I_{LED}}{(1 - D_{MAX})}$$

Allowing the peak-to-peak inductor ripple ΔI_L to be $\pm 30\%$ of the average inductor current (Equation 10).

Equation 10:

$$\Delta I_L = I_{L_AVG} \times 0.3 \times 2$$

and:

$$I_{L_P} = I_{L_AVG} + \frac{\Delta I_L}{2}$$

Calculate the minimum inductance value (L_{MIN}), in henries (H), with the inductor current ripple set to the maximum value (Equation 11).

Equation 11:

$$L_{\text{MIN}} = \frac{(V_{\text{IN_MIN}} - V_{\text{DS}} - 0.3) \times D_{\text{MAX}}}{f_{\text{SW}} \times \Delta\text{IL}}$$

Choose an inductor that has a minimum inductance greater than the calculated L_{MIN} and current rating greater than IL_{P} . The recommended saturation current limit of the selected inductor is 10% higher than the inductor peak current for boost configuration. For the coupled-inductor, the saturation limit of the inductor with only one winding conducting should be 10% higher than IL_{P} .

SEPIC Configuration

Power-circuit design for the SEPIC configuration is very similar to a conventional design with the output voltage referenced to the input supply voltage. For SEPIC, the output is referenced to ground and the inductor is split into two parts. One of the inductors (L_2) takes LED current as the average current and the other (L_1) takes input current as the average current.

Use the following equations (Equations 12–15) to calculate the average inductor currents ($IL_{1\text{AVG}}$, $IL_{2\text{AVG}}$) and peak inductor currents ($IL_{1\text{P}}$, $IL_{2\text{P}}$) in amperes.

Equation 12:

$$IL_{1\text{AVG}} = \frac{I_{\text{LED}} \times D_{\text{MAX}} \times 1.1}{1 - D_{\text{MAX}}}$$

The factor 1.1 provides a 10% margin to account for the converter losses (see Equation 13).

Equation 13:

$$IL_{2\text{AVG}} = I_{\text{LED}}$$

Assuming the peak-to-peak inductor ripple ΔIL is $\pm 30\%$ of the average inductor current (see Equation 14)

Equation 14:

$$\Delta\text{IL}_1 = IL_{1\text{AVG}} \times 0.3 \times 2$$

and:

$$IL_{1\text{P}} = IL_{1\text{AVG}} + \frac{\Delta\text{IL}_1}{2}$$

and:

$$\Delta\text{IL}_2 = IL_{2\text{AVG}} \times 0.3 \times 0.2$$

and:

$$IL_{2\text{P}} = IL_{2\text{AVG}} + \frac{\Delta\text{IL}_2}{2}$$

Calculate the minimum inductance values ($L_{1\text{MIN}}$ and $L_{2\text{MIN}}$) in henries with the inductor current ripple set to the maximum value shown in Equation 15.

Equation 15:

$$L_{1\text{MIN}} = \frac{(V_{\text{IN_MIN}} - V_{\text{DS}} - 0.3) \times D_{\text{MAX}}}{f_{\text{SW}} \times \Delta\text{IL}_1}$$

$$L_{2\text{MIN}} = \frac{(V_{\text{IN_MIN}} - V_{\text{DS}} - 0.3) \times D_{\text{MAX}}}{f_{\text{SW}} \times \Delta\text{IL}_2}$$

Choose inductors that have a minimum inductance greater than the calculated $L_{1\text{MIN}}$ and $L_{2\text{MIN}}$, and current rating greater than $IL_{1\text{P}}$ and $IL_{2\text{P}}$, respectively. The recommended saturation current limit of the selected inductor is 10% higher than the inductor peak current.

To simplify further calculations, consider L_1 and L_2 as a single inductor with L_1 and L_2 connected in parallel. The combined inductance value and current is calculated as shown in Equation 16.

Equation 16:

$$L = \frac{L_1 \times L_2}{L_1 + L_2}$$

and:

$$IL_{\text{AVG}} = IL_{1\text{AVG}} + IL_{2\text{AVG}}$$

where IL_{AVG} represents the total average current through both the inductors in the SEPIC configuration. Use these values in the calculations in the following sections.

Select coupling-capacitor C_S so the peak-to-peak ripple on it is less than 2% of the minimum input supply voltage. This ensures that the second-order effects created by the series-resonant circuit comprising L_1 , C_S , and L_2 do not affect the normal operation of the converter. Use Equation 17 to calculate the minimum value of C_S :

Equation 17:

$$C_S = \frac{I_{\text{LED}} \times D_{\text{MAX}}}{V_{\text{IN_MIN}} \times 0.02 \times f_{\text{SW}}}$$

where:

- C_S = Minimum value of the coupling capacitor in farads, and
- 0.02 = 2% ripple factor.

Slope Compensation and Current-Sense Resistor

The device generates a current ramp for slope compensation. This ramp current is in sync with the switching frequency and starts from zero at the beginning of every clock cycle, rising linearly to reach 50µA at the end of the clock cycle. The slope-compensating resistor (R_{SC}) is connected between the CS input and the source of the external switching MOSFET. This adds a programmable ramp voltage to the CS input voltage to provide slope compensation. Use one of the following equations (Equation 18 or Equation 19) to calculate the value of R_{SC} .

Equation 18 (for boost configurations):

$$R_{SC} = \frac{(V_{LED} - 2 \times V_{IN_MIN}) \times R_{CS} \times 3}{L_{MIN} \times 50\mu A \times f_{SW} \times 4}$$

Equation 19 (for SEPIC and coupled-inductor configurations):

$$R_{SC} = \frac{(V_{LED} - V_{IN_MIN}) \times R_{CS} \times 3}{L_{MIN} \times 50\mu A \times f_{SW} \times 4}$$

where:

- V_{LED} and V_{IN_MIN} are in volts,
- R_{SC} and R_{CS} are in ohms,
- L_{MIN} is in henries, and
- f_{SW} is in hertz.

The value of the switch current-sense resistor (R_{CS}) can be calculated using the boost configuration shown in Equation 20.

Equation 20:

$$0.39 \times 0.9 = I_{LP} \times R_{CS} + \frac{(D_{MAX} \times (V_{LED} - 2 \times V_{IN_MIN}) \times R_{CS} \times 3)}{4 \times L_{MIN} \times f_{SW}}$$

For SEPIC and coupled-inductor configurations, use Equation 21.

Equation 21:

$$0.39 \times 0.9 = I_{LP} \times R_{CS} + \frac{(D_{MAX} \times (V_{LED} - V_{IN_MIN}) \times R_{CS} \times 3)}{4 \times L_{MIN} \times f_{SW}}$$

where 0.39 is the minimum value of the peak current-sense threshold. The current-sense threshold also includes the slope-compensation component. The minimum current-sense threshold of 0.39 is multiplied by 0.9 to take tolerances into account.

Output Capacitor Selection

For all three converter topologies, the output capacitor supplies the load current when the main switch is on. The function of the output capacitor is to reduce the converter output ripple to acceptable levels. The entire output-voltage ripple appears across constant-current sink outputs because the LED string voltages are stable due to the constant current. For the MAX20446, limit peak-to-peak output-voltage ripple to 200mV to get stable output current.

The ESR, ESL, and bulk capacitance of the output capacitor contribute to the output ripple. In most applications, using low-ESR ceramic capacitors can dramatically reduce the output ESR and ESL effects. To reduce the ESL and ESR effects, connect multiple ceramic capacitors in parallel to achieve the required bulk capacitance. To minimize audible noise during PWM dimming, the amount of ceramic capacitors on the output are usually minimized. In this case, an additional electrolytic or aluminum organic polymer capacitor provides most of the bulk capacitance.

External Switching MOSFET Selection

The external switching MOSFET should have a voltage rating sufficient to withstand the maximum boost output voltage, together with the rectifier diode drop and any possible overshoot due to ringing caused by parasitic inductance and capacitance. The recommended MOSFET V_{DS} voltage rating is 30% higher than the sum of the maximum output voltage and the rectifier diode drop.

The continuous-drain current rating of the MOSFET (I_D), when the case temperature is at +70°C, should be greater than that calculated in Equations 22 and 23.

Equation 22:

$$I_{DRMS} = \left(\sqrt{I_{L_AVG}^2 \times D_{MAX}} \right) \times 1.3$$

The MOSFET dissipates power due to both switching losses and conduction losses. Use the Equation 24 to calculate the conduction losses in the MOSFET.

Equation 24:

$$P_{COND} = I_{L_AVG}^2 \times D_{MAX} \times R_{DS(ON)}$$

where $R_{DS(ON)}$ is the on-state drain-to-source resistance of the MOSFET. Use the Equation 25 to calculate the switching losses in the MOSFET.

Equation 25:

$$P_{SW} = \frac{I_{LAVG} \times V_{LED}^2 \times C_{GD} \times f_{SW}}{2} \times \left(\frac{1}{I_{GON}} + \frac{1}{I_{GOFF}} \right)$$

where I_{GON} and I_{GOFF} are the gate currents of the MOSFET in amperes when it is turned on and turned off, respectively. C_{GD} is the gate-to-drain MOSFET capacitance in farads.

Rectifier Diode Selection

Using a Schottky rectifier diode produces less forward drop and puts the least burden on the MOSFET during reverse recovery. A diode with considerable reverse-recovery time increases the MOSFET switching loss. Select a Schottky diode with a voltage rating 20% higher than the maximum boost-converter output voltage, and current rating greater than $I_{LAVG} \times (1-D_{MAX}) \times 1.2$

Feedback Compensation

During normal operation, the feedback control loop regulates the minimum OUT_{-} voltage to fall within the window comparator limits of 0.78V and 1.03V when LED string currents are enabled during PWM dimming. When LED currents are off during PWM dimming, the control loop turns off the converter and stores the steady-state condition in the form of capacitor voltages, mainly the output-filter-capacitor voltage and the compensation-capacitor voltage.

The switching converter small-signal-transfer function has a right-half plane (RHP) zero in the boost configuration if the inductor current is in continuous-conduction mode. The RHP zero adds a 20dB/decade gain together with a 90° phase lag, which is difficult to compensate.

The worst-case RHP zero frequency (f_{ZRHP}) is calculated for boost configuration, as shown in Equation 22.

Equation 22:

$$f_{ZRHP} = \frac{V_{LED} \times (1 - D_{MAX})^2}{2 \times \pi \times L \times I_{LED}}$$

For the SEPIC and coupled-inductor configurations, see Equation 23.

Equation 23:

$$f_{ZRHP} = \frac{V_{LED} \times (1 - D_{MAX})^2}{2 \times \pi \times L \times I_{LED} \times D_{MAX}}$$

The standard way to avoid this zero is to roll off the loop gain to 0dB at a frequency less than 1/5 of the RHP zero frequency with a -20dB/decade slope.

The switching converter small-signal-transfer function also has an output pole. The effective output impedance, together with the output filter capacitance, determine the output pole frequency (f_{P1}), as shown in Equation 24 and Equation 25.

Equation 24 (for boost configurations):

$$f_{P1} = \frac{I_{LED}}{\pi \times V_{LED} \times C_{OUT}}$$

Equation 25 (for SEPIC and couple-inductor configurations):

$$f_{P1} = \frac{I_{LED} \times D_{MAX}}{\pi \times V_{LED} \times C_{OUT}}$$

Compensation components R_{COMP} and C_{COMP} perform two functions: C_{COMP} introduces a low-frequency pole that presents a -20dB/decade slope to the loop gain, and R_{COMP} flattens the gain of the error amplifier for frequencies above the zero formed by R_{COMP} and C_{COMP} . For compensation, this zero is placed at f_{P1} to provide a -20dB/decade slope for frequencies above f_{P1} to the combined modulator and compensator response.

The value of R_{COMP} , needed to fix the total loop gain at f_{P1} so that the total loop gain crosses 0dB with -20dB/decade slope at 1/5 the RHP zero frequency, is calculated as shown in Equation 26.

Equation 26 (for boost configurations):

$$R_{COMP} = \frac{f_{ZRHP} \times R_{CS} \times I_{LED} \times A_{OVP}}{5 \times f_{P1} \times GM_{COMP} \times V_{LED} \times (1 - D_{MAX})}$$

Equation 27 (for SEPIC and coupled-inductor buck-boost configurations):

$$R_{COMP} = \frac{f_{ZRHP} \times R_{CS} \times I_{LED} \times A_{OVP} \times D_{MAX}}{5 \times f_{P1} \times GM_{COMP} \times V_{LED} \times (1 - D_{MAX})}$$

where:

- R_{COMP} = Compensation resistor in ohms,
- A_{OVP} = BSTMON resistor-divider gain (a value $\ll 1$),
- R_{CS} = Current-sense resistor in ohms, and
- GM_{COMP} = Transconductance of the error amplifier (700 μ S).

The value of C_{COMP} is calculated in Equation 28.

Equation 28:

$$C_{COMP} = \frac{1}{2 \times \pi \times f_{Z1} \times R_{COMP}}$$

where f_{Z1} is the compensation zero placed at 1/5 the crossover frequency, which is, in turn, set at 1/5 the f_{ZRHP} . If the output capacitors do not have low ESR, the ESR zero frequency could fall below the 0dB crossover frequency. An additional pole may be required to cancel out this pole placed at the same frequency. This can be added by connecting a capacitor from the COMP pin directly to GND, with a value shown in Equation 29.

Equation 29:

$$GM_{COMP} \times R_{ESR} \times C_{OUT}$$

where R_{ESR} is the capacitor ESR value and C_{OUT} is the output-capacitor value.

Loop-Stability Verification

To verify the loop stability, it is prudent to use a loop analyzer to study the closed-loop gain and phase against frequency. To check the closed-loop gain, connect the test and reference probes of the analyzer, as shown in [Figure 4](#).

Perform the test after starting up the device with the DIM pin set to 0 and a dummy resistive load connected on the output of the boost converter (the LED load is not

needed). Use an injection transformer to insert the injection voltage from test to ref. The loop analyzer can plot the gain and phase of the closed loop, where the loop gain is TJW/RJW . The crossover frequency occurs at the frequency where the gain is 0db. To guarantee stable operation, the phase margin at that frequency should exceed 45° at the lowest input frequency and maximum load. The optimum phase margin would exceed 60°.

External Disconnect-MOSFET Selection

An external pMOSFET can be used to disconnect the boost output from the battery in the event of an output overload or short condition. In the case of the SEPIC or buck-boost, this protection is not necessary so there is no need for the pMOSFET. Connect the PGATE pin to ground in the case of the SEPIC and buck-boost. If necessary to have an output short protection for the boost even at power-up, the current through the pMOSFET (see the [Typical Application Circuit—Boost](#)) has to be sensed. Once the current-sense voltage exceeds a certain threshold, it should limit the input current to the programmed threshold. This threshold should be set at a sufficiently high level so it never trips at startup or under normal operating conditions. Check the safe operating area (SOA) of the pMOSFET so the current-limit trip threshold and voltage on the MOSFET do not exceed the limits of the SOA curve of the pMOSFET at the highest operating temperature.

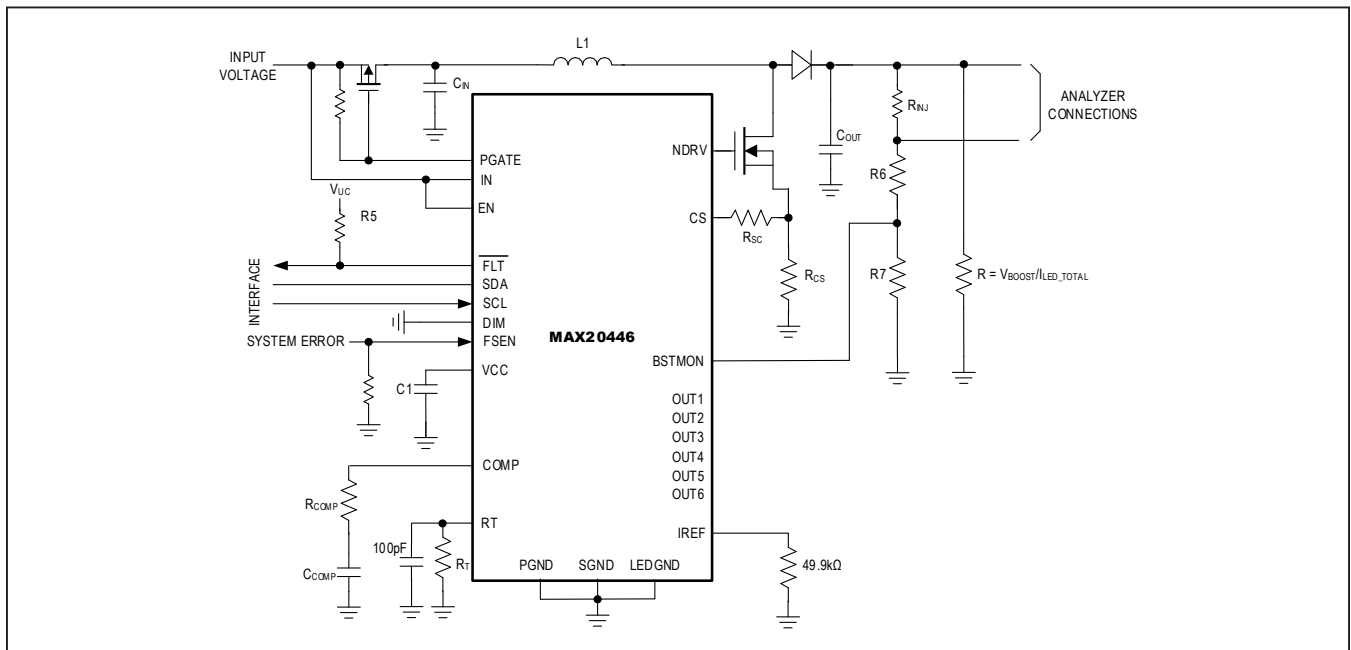

Figure 4. Loop-Stability Verification

V_{OUT} to OUT_ Bleed Resistors

The OUT_ pins have a leakage specification of 12μA (max) in cases where all OUT_ pins are shorted to 48V (see I_{OUTLEAK} in the [Electrical Characteristics](#) table). This leakage current is dependent on the OUT_ voltage and is higher at higher voltages. Therefore, in cases where large numbers of LEDs are connected in series, a 100kΩ (or larger) bleed resistor can be placed in parallel with the LED string to prevent the OUT_ leakage current from very dimly turning on the LEDs, even when the DIM signal is low (see resistors R8–R13 in the [Typical Application Circuit—Boost](#)).

Thermal Considerations

The on-chip power dissipation of the MAX20446 comprises two main factors:

- Current-sink power loss: $1.1V \times I_{LED}$
- Device operating current power loss: $V_{IN} \times 15mA$

Calculate the total power dissipation by adding the two values calculated above. The junction temperature at the maximum ambient temperature can then be calculated using Equation 30.

Equation 30:

$$T_J = T_A + P_{TOT} \times \theta_{JA}$$

where T_A is the ambient temperature and θ_{JA} is the junction-to-ambient thermal resistance of the package (36°C/W on a four-layer board). Ensure that the junction temperature does not exceed 150°C.

As an example, consider an application with an operating voltage of 14V and a total output current of 600mA (the total power dissipation is shown in Equation 31).

Equation 31:

$$P_{TOT} = 1.1 \times 0.6 + 14 \times 0.15 = 0.87W$$

and the maximum junction temperature at an ambient temperature of 85°C is shown in Equation 32.

Equation 32:

$$T_J = 85 + 0.87 \times 36 = 116 \text{ } ^\circ\text{C}$$

PCB Layout Considerations

LED driver circuits based on the MAX20446 use a high-frequency switching converter to generate the voltage for LED strings. Take proper care while laying out the circuit to ensure correct operation. The switching-converter portion of the circuit has nodes with very fast voltage changes that could lead to undesirable effects on the sensitive parts of the circuit. Follow the [PCB Layout Guidelines](#) to reduce noise as much as possible.

PCB Layout Guidelines

- Connect the bypass capacitor on V_{CC} as close as possible to the device and connect the capacitor ground to the analog ground plane using vias close to the capacitor terminal. Connect the GND of the device to the analog ground plane using a via close to GND. Lay the analog ground plane on the inner layer, preferably next to the top layer. Use the analog ground plane to cover the entire area under critical signal components for the power converter.
- Have a power-ground plane for the switching-converter power circuit under the power components (i.e., input filter capacitor, output filter capacitor, inductor, MOSFET, rectifier diode, and current-sense resistor). Connect PGND to the power-ground plane closest to PGND. Connect all other ground connections to the power ground plane using vias close to the terminals.
- There are two loops in the power circuit that carry high-frequency switching currents. One loop is when the MOSFET is on (from the input filter capacitor positive terminal, through the inductor, the internal MOSFET and the current-sense resistor, to the input capacitor negative terminal). The other loop is when the MOSFET is off (from the input capacitor positive terminal, through the inductor, the rectifier diode, output filter capacitor, to the input capacitor negative terminal). Analyze these two loops and make the loop areas as small as possible. Wherever possible, have a return path on the power ground plane for the switching currents on the top-layer copper traces, or through power components. This reduces the loop area considerably and provides a low-inductance path for the switching currents. Reducing the loop area also reduces radiation during switching.
- Connect the power-ground plane for the constant-current LED driver portion of the circuit to LEDGND as close as possible to the device. Connect GND to PGND at the same point.
- Add a small bypass capacitor (22pF to 47pF) to the BSTMON input. Place the capacitor as close as possible to the pin to suppress high-frequency noise.
- Boost output voltage for the LED strings should be taken directly from the output capacitors and not from the boost diode anode.
- Input and output capacitors need good grounding with wide traces and multiple vias to the ground plane.
- Refer to the MAX20446 evaluation kit (EV kit) data sheet for an example layout.

Typical Application Circuit—Boost

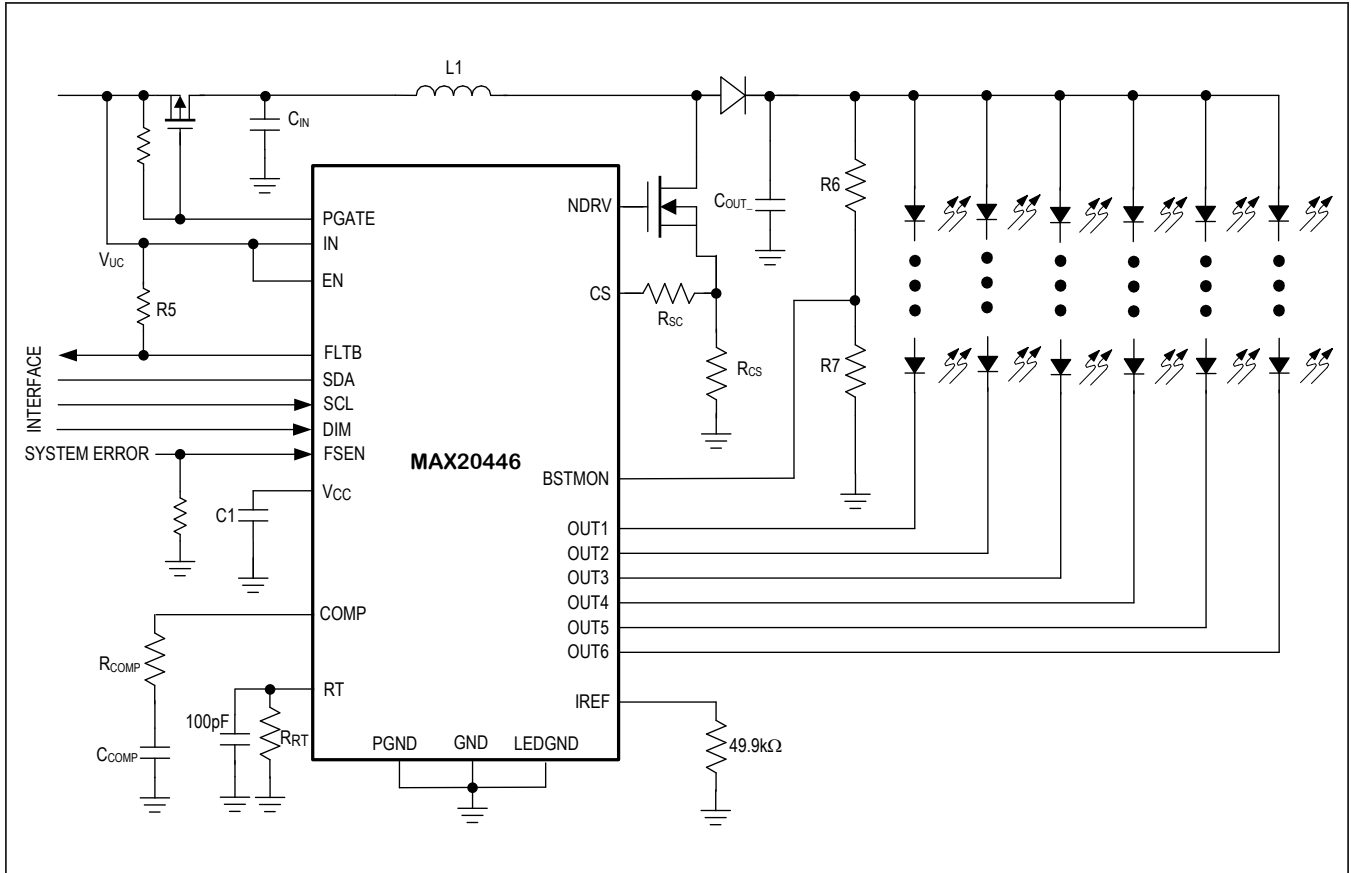

Typical Application Circuit—SEPIC

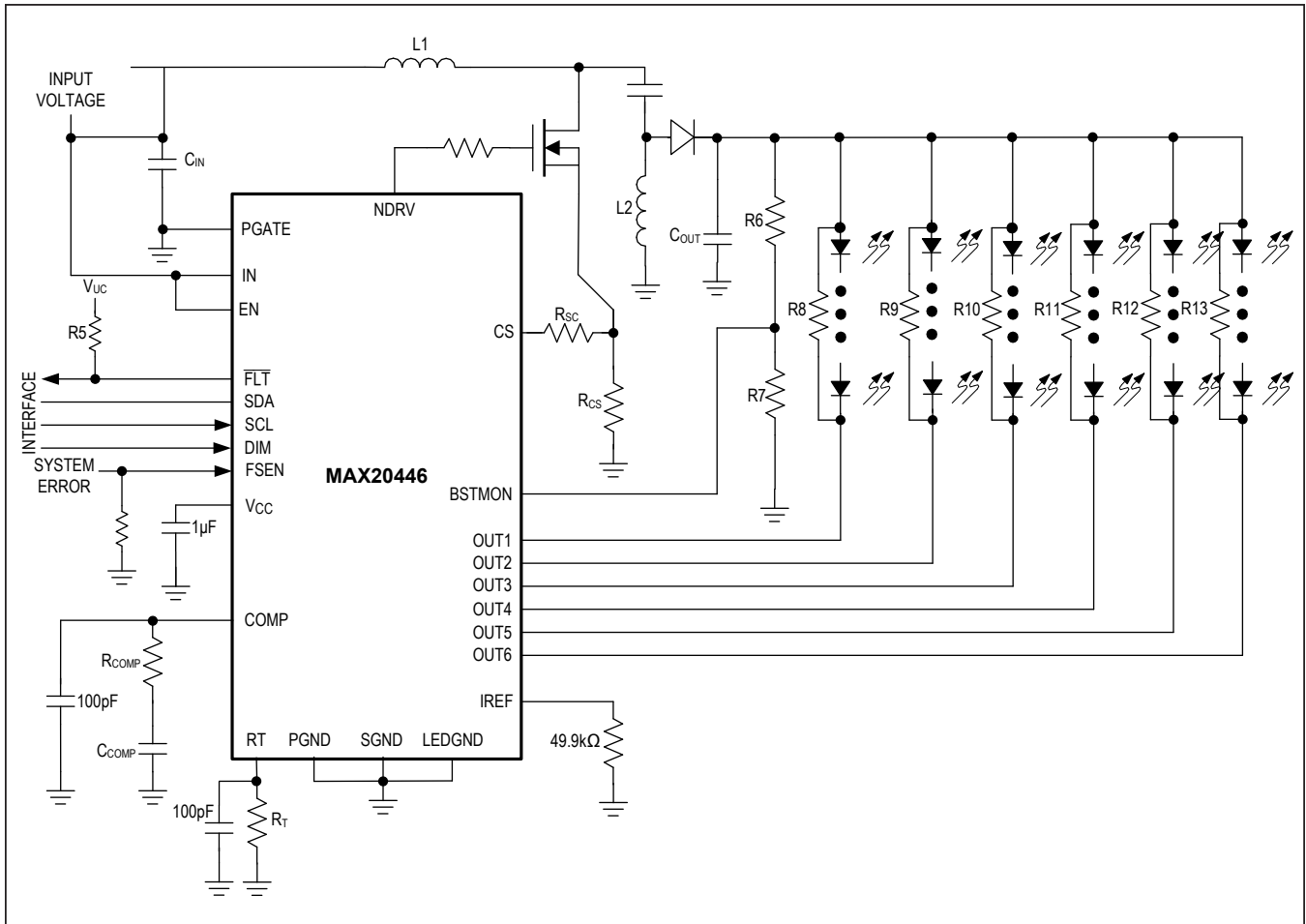

Ordering Information

PART	PIN-PACKAGE
MAX20446ATG/V+	24 TQFN-EP*
MAX20446ATG/VY+	24 SWTQFN-EP*
MAX20446ATG/V+T	24 TQFN-EP*
MAX20446ATG/VY+T	24 SWTQFN-EP*

Note: All parts operate over the -40°C to +125°C temperature range.

V = Denotes an automotive-qualified part.

+Denotes a lead(Pb)-free/RoHS-compliant package.

SW = Side-wettable package.

T = Tape and reel.

*EP = Exposed pad.