



1.8V to 4.25V-Powered, True RS-232 Dual Transceiver

MAX218

General Description

The MAX218 RS-232 transceiver is intended for battery-powered EIA/TIA-232E and V.28/V.24 communications interfaces that need two drivers and two receivers with minimum power consumption. It provides a wide +1.8V to +4.25V operating voltage range while maintaining true RS-232 and EIA/TIA-562 voltage levels. The MAX218 runs from two alkaline, NiCd, or NiMH cells without any form of voltage regulator.

A shutdown mode reduces current consumption to 1µA, extending battery life in portable systems. While shut down, all receivers can remain active or can be disabled under logic control, permitting a system incorporating the CMOS MAX218 to monitor external devices while in low-power shutdown mode.

A guaranteed 120kbps data rate provides compatibility with popular software for communicating with personal computers. Three-state drivers are provided on all receiver outputs so that multiple receivers, generally of different interface standards, can be wire-ORed at the UART. The MAX218 is available in 20-pin DIP, SO, and SSOP packages.

Applications

- Battery-Powered Equipment
- Computers
- Printers
- Peripherals
- Instruments
- Modems

Typical Operating Circuit

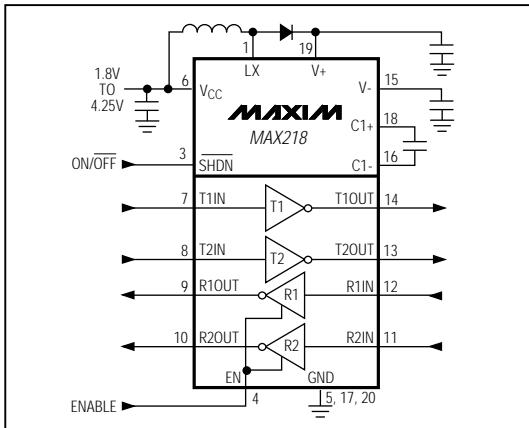

Features

BETTER THAN BIPOLAR!

- ◆ Operates Directly from Two Alkaline, NiCd, or NiMH Cells
- ◆ +1.8V to +4.25V Supply Voltage Range
- ◆ 120kbps Data Rate
- ◆ Low-Cost Surface-Mount Components
- ◆ Meets EIA/TIA-232E Specifications
- ◆ 1µA Low-Power Shutdown Mode
- ◆ Both Receivers Active During Low-Power Shutdown
- ◆ Three-State Receiver Outputs
- ◆ Flow-Through Pinout
- ◆ On-Board DC-DC Converters
- ◆ 20-Pin SSOP, Wide SO, or DIP Packages

Ordering Information

PART	TEMP. RANGE	PIN-PACKAGE
MAX218CPP	0°C to +70°C	20 Plastic DIP
MAX218CWP	0°C to +70°C	20 Wide SO
MAX218CAP	0°C to +70°C	20 SSOP
MAX218C/D	0°C to +70°C	Dice*
MAX218EPP	-40°C to +85°C	20 Plastic DIP
MAX218EWP	-40°C to +85°C	20 Wide SO
MAX218EAP	-40°C to +85°C	20 SSOP

*Contact factory for dice specifications.

Pin Configuration

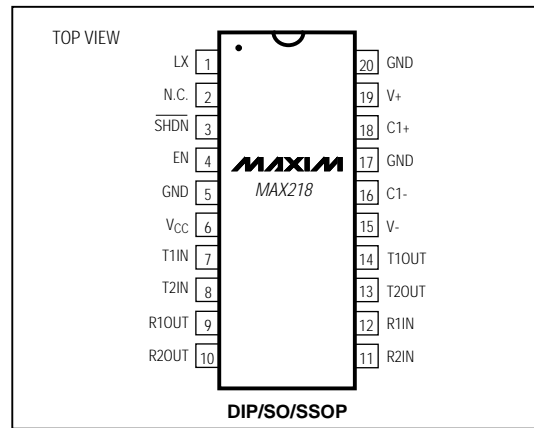

1.8V to 4.25V-Powered, True RS-232 Dual Transceiver

ABSOLUTE MAXIMUM RATINGS

Supply Voltages		Short-Circuit Duration, R_OUT, T_OUT to GND Continuous
V _{CC}-0.3V to +4.6V	Continuous Power Dissipation (T _A = +70°C)	
V ₊ (V _{CC} - 0.3V) to +7.5V	Plastic DIP (derate 11.11mW/°C above +70°C)889mW
V ₋+0.3V to -7.4V	Wide SO (derate 10.00mW/°C above +70°C)800mW
V _{CC} to V ₋+12V	SSOP (derate 8.00mW/°C above +70°C)640mW
LX-0.3V to (1V + V ₊)	Operating Temperature Ranges	
Input Voltages		MAX218C_P 0°C to +70°C
T_IN, EN, SHDN -0.3V to +7V	MAX218E_P -40°C to +85°C
R_IN±25V	Storage Temperature Range -65°C to +150°C
Output Voltages		Lead Temperature (soldering, 10sec) +300°C
T_OUT±15V		
R_OUT-0.3V to (V _{CC} + 0.3V)		

Stresses beyond those listed under "Absolute Maximum Ratings" may cause permanent damage to the device. These are stress ratings only, and functional operation of the device at these or any other conditions beyond those indicated in the operational sections of the specifications is not implied. Exposure to absolute maximum rating conditions for extended periods may affect device reliability.

ELECTRICAL CHARACTERISTICS

(Circuit of Figure 1, V_{CC} = 1.8V to 4.25V, C1 = 0.47μF, C2 = C3 = C4 = 1μF, L1 = 15μH, T_A = T_{MIN} to T_{MAX}, unless otherwise noted. Typical values are at V_{CC} = 3.0V, T_A = +25°C.)

PARAMETER	CONDITIONS	MIN	TYP	MAX	UNITS
DC CHARACTERISTICS					
Operating Voltage Range		1.8		4.25	V
Supply Current (Note 1)	No load, V _{CC} = EN = SHDN = 3.0V, T _A = +25°C		1.9	3.0	mA
Shutdown Supply Current	SHDN = EN = 0V, all R_INs static		0.04	10	μA
	SHDN = 0V, EN = V _{CC} , all R_INs static		0.04	10	
LOGIC					
Input Logic Threshold Low	T_IN, EN, SHDN			0.33 x V _{CC}	V
Input Logic Threshold High	T_IN, EN, SHDN	0.67 x V _{CC}			V
Input Hysteresis	T_IN		0.1		V
Input Leakage Current	T_IN, EN, SHDN = 0V or V _{CC}		0.001	±1	μA
Output Voltage Low	R_OUT, I_OUT = 1.0mA			0.4	V
Output Voltage High	R_OUT, I_OUT = -0.4mA	V _{CC} - 0.25	V _{CC} - 0.08		V
Output Leakage Current	R_OUT, 0V ≤ R_OUT ≤ V _{CC} , EN = 0V		0.05	±10	μA
EIA/TIA-232E RECEIVER INPUTS					
Input Voltage Range		-25		+25	V
Input Threshold Low	V _{CC} = 2.0V to 4.25V	0.4			V
	V _{CC} = 1.8V to 4.25V	0.3			
Input Threshold High	V _{CC} = 1.8V to 4.25V			3.0	V
	V _{CC} = 1.8V to 3.6V			2.8	
Input Hysteresis			0.7		V
Input Resistance	-15V < R_IN < +15V	3	5	7	kΩ
EIA/TIA-232E TRANSMITTER OUTPUTS					
Output Voltage Swing	All transmitter outputs loaded with 3kΩ to ground	±5	±6		V
Output Resistance	V _{CC} = 0V, -2V < T_OUT < +2V	300			Ω
Output Short-Circuit Current			±24	±100	mA

Note 1: Entire supply current for the circuit of Figure 1.

1.8V to 4.25V-Powered, True RS-232 Dual Transceiver

MAX218

TIMING CHARACTERISTICS

(Circuit of Figure 1, $V_{CC} = 1.8V$ to $4.25V$, $C1 = 0.47\mu F$, $C2 = C3 = C4 = 1\mu F$, $L1 = 15\mu H$, $T_A = T_{MIN}$ to T_{MAX} , unless otherwise noted. Typical values are at $V_{CC} = 3.0V$, $T_A = +25^\circ C$.)

PARAMETER	SYMBOL	CONDITIONS	MIN	TYP	MAX	UNITS
Data Rate		1000pF 3k Ω load each transmitter, 150pF load each receiver	120			kbps
Receiver Output Enable Time	t _{ER}			90	300	ns
Receiver Output Disable Time	t _{DR}			200	500	ns
Transmitter Output Enable Time	t _{ET}			140	450	μs
Transmitter Output Disable Time	t _{DT}			500		ns
Receiver Propagation Delay	t _{PHLR}	150pF load		290	700	ns
	t _{PLHR}	150pF load		260	700	
Transmitter Propagation Delay	t _{PHLT}	2500pF 3k Ω load		1.9	2.7	μs
	t _{PLHT}	2500pF 3k Ω load		1.8	2.7	
Transition Region Slew Rate		$T_A = +25^\circ C$, $V_{CC} = 3.0V$, $R_L = 3k\Omega$ to $7k\Omega$, $C_L = 50pF$ to $2500pF$, measured from $+3V$ to $-3V$ or $-3V$ to $+3V$	3.0		30	V/ μs

Pin Description

PIN	NAME	FUNCTION
1	LX	Inductor/Diode Connection Point
2	N.C.	Not internally connected
3	\overline{SHDN}	Shutdown Control. Connect to V_{CC} for normal operation. Connect to GND to shut down the power supply and to disable the drivers. Receiver status is not changed by this control.
4	EN	Receiver Output Enable Control. Connect to V_{CC} for normal operation. Connect to GND to force the receiver outputs into high-Z state.
5, 17, 20	GND	Ground. Connect all GND pins to ground.
6	V_{CC}	Supply Voltage Input; 1.8V to 4.25V. Bypass to GND with at least $1\mu F$. See <i>Capacitor Selection</i> section.
7, 8	T1IN, T2IN	Transmitter Inputs
9, 10	R1OUT, R2OUT	Receiver Outputs; swing between GND and V_{CC} .
11, 12	R2IN, R1IN	Receiver Inputs
13, 14	T2OUT, T1OUT	Transmitter Outputs; swing between $V+$ and $V-$.
15	$V-$	Negative Supply generated on-board
16, 18	C1-, C1+	Terminals for Negative Charge-Pump Capacitor
19	$V+$	Positive Supply generated on-board

1.8V to 4.25V-Powered, True RS-232 Dual Transceiver

Typical Operating Characteristics

(Circuit of Figure 1, $V_{CC} = 1.8V$, all transmitter outputs loaded with $3k\Omega$, $T_A = +25^\circ C$, unless otherwise noted.)

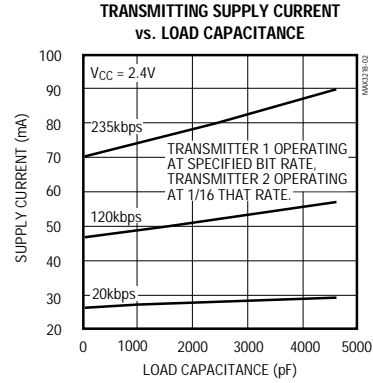
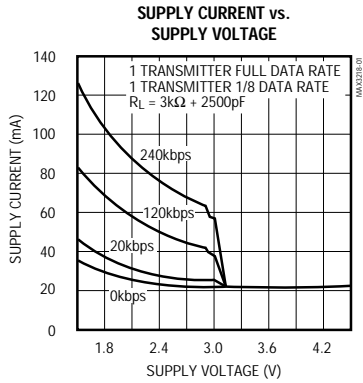

TIME TO EXIT SHUTDOWN (ONE TRANSMITTER HIGH, ONE TRANSMITTER LOW)

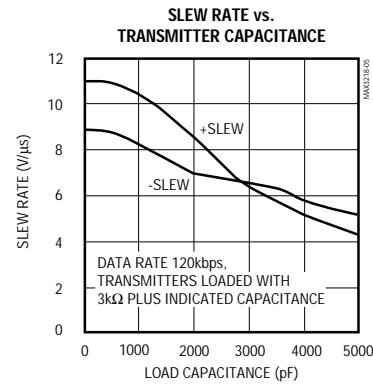
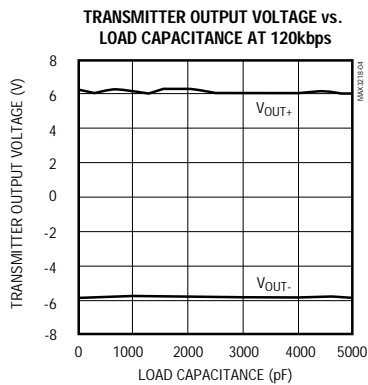
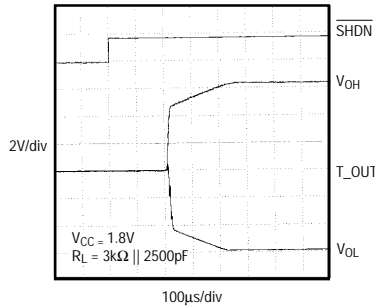

1.8V to 4.25V-Powered, True RS-232 Dual Transceiver

MAX218

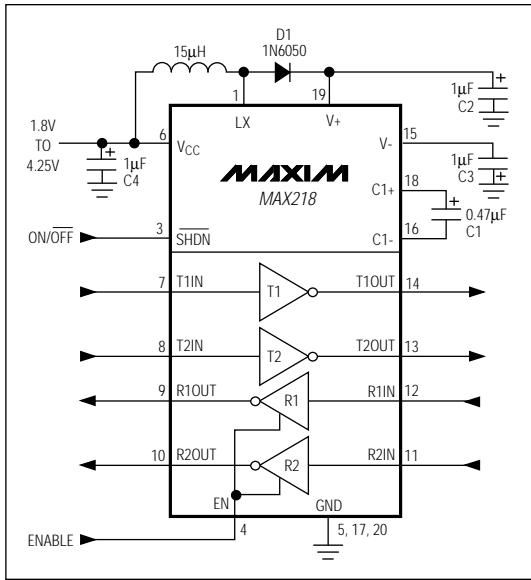

Figure 1. Single-Supply Operation

Detailed Description

The MAX218 line driver/receiver is intended for battery-powered EIA/TIA-232 and V.28/V.24 communications interfaces that require two drivers and two receivers. The operating voltage extends from 1.8V to 4.25V, yet the device maintains true RS-232 and EIA/TIA-562 transmitter output voltage levels. This wide supply voltage range permits direct operation from a variety of batteries without the need for a voltage regulator. For example, the MAX218 can be run directly from a single lithium cell or a pair of alkaline cells. It can also be run directly from two NiCd or NiMH cells from full-charge voltage down to the normal 0.9V/cell end-of-life point. The 4.25V maximum supply voltage allows the two rechargeable cells to be trickle- or fast-charged while driving the MAX218.

The circuit comprises three sections: power supply, transmitters, and receivers. The power-supply section converts the supplied input voltage to 6.5V, providing the voltages necessary for the drivers to meet true RS-232 levels. External components are small and inexpensive.

The transmitters and receivers are guaranteed to operate at 120kbps data rates, providing compatibility with LapLink™ and other high-speed communications software. A shutdown mode extends battery life by reducing supply current to 0.04µA. While shut down, all receivers can either remain active or be disabled under logic control. With this feature, the MAX218 can be in low-power shutdown mode and still monitor activity on external devices. Three-state drivers are provided on both receiver outputs.

Switch-Mode Power Supply

The switch-mode power supply uses a single inductor with one diode and three small capacitors to generate ±6.5V from an input voltage in the 1.8V to 4.25V range.

Inductor Selection

Use a 15µH inductor with a saturation current rating of at least 350mA and less than 1Ω resistance. Table 1 lists suppliers of inductors that meet the 15µH/350mA/1Ω specifications.

Diode Selection

Key diode specifications are fast recovery time (<10ns), average current rating (>100mA), and peak current rating (>350mA). Inexpensive fast silicon diodes, such as the 1N6050, are generally recommended. More expensive Schottky diodes improve efficiency and give slightly better performance at very low V_{CC} voltages. Table 1 lists suppliers of both surface-mount and through-hole diodes. 1N914s are usually satisfactory, but specifications and performance vary widely with different manufacturers.

Capacitor Selection

Use capacitors with values at least as indicated in Figure 1. Capacitor C2 determines the ripple on V+, but not the absolute voltage. Capacitors C1 and C3 determine both the ripple and the absolute voltage of V-. Bypass V_{CC} to GND with at least 1µF (C4) placed close to pins 5 and 6. If the V_{CC} line is not bypassed elsewhere (e.g., at the power supply), increase C4 to 4.7µF.

You may use ceramic or polarized capacitors in all locations. If you use polarized capacitors, tantalum types are preferred because of the high operating frequency of the power supplies (about 250kHz). If aluminum electrolytics are used, higher capacitance values may be required.

™ LapLink is a trademark of Traveling Software, Inc.

1.8V to 4.25V-Powered, True RS-232 Dual Transceiver

Table 1. Suggested Component Suppliers

MANUFACTURER	PART NUMBER	PHONE	FAX
Inductors—Surface Mount			
Murata-Erie	LOH4N150K-TA	USA (404) 436-1300 Japan (075) 951-9111	USA (404) 436-3030 Japan (075) 955-6526
Sumida	CD43150	USA (708) 956-0666 Japan (03) 3607-5111	USA (708) 956-0702 Japan (03) 3607-5428
TDK	NLC453232T-150K	USA (708) 803-6100 Japan (03) 3278-5111	USA (708) 803-6296 Japan (03) 3278-5358
Diodes—Surface Mount			
Central Semiconductor	CMPSH-3, Schottky	USA (516) 435-1110	USA (516) 435-1824
Motorola	MMBD6050LT1, Silicon	USA (408) 749-0510	USA (408) 991-7420
Philips	PMBD6050, Silicon	USA (401) 762-3800	USA (401) 767-4493
Diodes—Through-Hole			
Motorola	1N6050, Silicon 1N5817, Schottky	USA (408) 749-0510	USA (408) 991-7420

RS-232 Drivers

The two drivers are identical, and deliver EIA/TIA-232E and EIA/TIA-562 output voltage levels when V_{DD} is between 1.8V and 4.25V. The transmitters drive up to $3k\Omega$ in parallel with 1000pF at up to 120kbps. Connect unused driver inputs to either GND or V_{CC} . Disable the drivers by taking \overline{SHDN} low. The transmitter outputs are forced into a high-impedance state when \overline{SHDN} is low.

RS-232 Receivers

The two receivers are identical, and accept both EIA/TIA-232E and EIA/TIA-562 input signals. The CMOS receiver outputs swing rail-to-rail. When EN is high, the receivers are active regardless of the state of \overline{SHDN} . When EN is low, the receiver outputs are put into a high-impedance state. This allows two RS-232 ports (or two ports of different types) to be wired-ORed at the UART.

Operating Modes

\overline{SHDN} and EN determine the MAX218's mode of operation, as shown in Table 2.

Table 2. Operating Modes

\overline{SHDN}	EN	RECEIVER OUTPUT	DRIVER OUTPUT	DC-DC CONVERTER	SUPPLY CURRENT
L	L	High-Z	High-Z	OFF	Minimum
L	H	Enabled	High-Z	OFF	Minimum
H	L	High-Z	Enabled	ON	Normal
H	H	Enabled	Enabled	ON	Normal

Shutdown

When \overline{SHDN} is low, the power supplies are disabled and the transmitters are put into a high-impedance state. Receiver operation is not affected by taking \overline{SHDN} low. Power consumption is dramatically reduced in shutdown mode. Supply current is minimized when the receiver inputs are static in any of three states: floating (ground), GND, or V_{CC} .

Applications Information

Operation from Regulated/Unregulated Dual System Power Supplies

The MAX218 is intended for use with three different power-supply sources: it can be powered directly from a battery, from a 3.0V or 3.3V power supply, or simultaneously from both. Figure 1 shows the single-supply configuration. Figure 2 shows the circuit for operation from both a 3V supply and a raw battery supply—an ideal configuration where a regulated 3V supply is being derived from two cells. In this application, the MAX218's logic levels remain appropriate for interface with 3V logic, yet most of the power for the MAX218 is drawn directly from the battery, without suffering the efficiency losses of the DC-DC converter. This prolongs battery life.

Bypass the input supplies with 0.1 μ F at V_{CC} (C4) and at least 1 μ F at the inductor (C5). Increase C5 to 4.7 μ F if the power supply has no other bypass capacitor connected to it.

1.8V to 4.25V-Powered, True RS-232 Dual Transceiver

MAX218

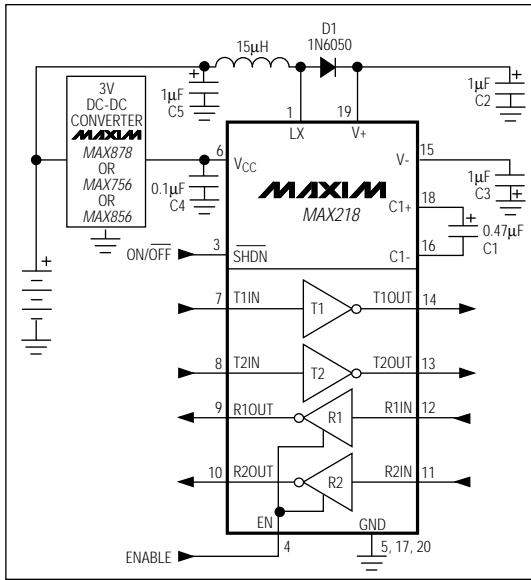

Figure 2. Operating from Unregulated and Regulated Supplies

Low-Power Operation

The following suggestions will help you get maximum life out of your batteries.

Shut the MAX218 down when it is not being used for transmission. The receivers can remain active when the MAX218 is shut down, to alert your system to external activity.

Transmit at the highest practical data rate. Although this raises the supply current while transmission is in progress, the transmission will be over sooner. As long as the MAX218 is shut down as soon as each transmission ends, this practice will save energy.

Operate your whole system from the raw battery voltage rather than suffer the losses of a regulator or DC-DC converter. If this is not possible, but your system is powered from two cells and employs a 3V DC-DC converter to generate the main logic supply, use the circuit of Figure 2. This circuit draws most of the MAX218's

power straight from the battery, but still provides logic-level compatibility with the 3V logic.

Keep communications cables short to minimize capacitive loading. Lowering the capacitive loading on the transmitter outputs reduces the MAX218's power consumption. Using short, low-capacitance cable also helps transmission at the highest data rates.

Keep the $\overline{\text{SHDN}}$ pin low while power is being applied to the MAX218, and take SHDN high only after V_{CC} has risen above about 1.5V. This avoids active operation at very low voltages, where currents of up to 150mA can be drawn. This is especially important with systems powered from rechargeable cells; if SHDN is high while the cells are being trickle charged from a deep discharge, the MAX218 could draw a significant amount of the charging current until the battery voltage rises above 1.5V.

Pin Configuration Change

The *Pin Configuration* shows pin 2 as N.C. (no connect). Early samples had a bypass capacitor for the internal reference connected to pin 2, which was labeled REF. This bypass capacitor proved to be unnecessary and the connection has been omitted. Pin 2 may now be connected to ground, left open, or bypassed to GND with a capacitor.

EIA/TIA-232E and EIA/TIA-562 Standards

RS-232 circuits consume much of their power because the EIA/TIA-232E standard demands that the transmitters deliver at least 5V to receivers with impedances that can be as low as 3k Ω . For applications where power consumption is critical, the EIA/TIA-562 standard provides an alternative.

EIA/TIA-562 transmitter output voltage levels need only reach $\pm 3.7\text{V}$, and because they have to drive the same 3k Ω receiver loads, the total power consumption is considerably reduced. Since the EIA/TIA-232E and EIA/TIA-562 receiver input voltage thresholds are the same, interoperability between EIA/TIA-232E and EIA/TIA-562 devices is guaranteed. Maxim's MAX560 and MAX561 are EIA/TIA-562 transceivers that operate on a single supply from 3.0V to 3.6V, and the MAX562 transceiver operates from 2.7V to 5.25V while producing EIA/TIA-562 levels.