

## MAX25530 Evaluation Kit

Evaluates: MAX25530

### General Description

The MAX25530 evaluation kit (EV kit) demonstrates the MAX25530 IC, which is a highly integrated power supply plus LED backlight driver for automotive TFT-LCD applications. The EV kit is a fully assembled and tested surface-mount PCB that provides a complete power-management solution for automotive displays. The EV kit demonstrates one buck-boost converter, one boost converter, two gate-voltage controllers, and a boost converter that powers a quad-string LED driver.

The EV kit can be configured to operate in a stand-alone mode or in an I<sup>2</sup>C mode.

The TFT bias section of the EV kit operates from a 2.8V to 5.5V DC supply voltage. The step-up switching regulator (POS) is configured for a 5V to 18V output that provides up to 120mA. The inverting buck-boost converter (NEG) generates a negative output that tracks the positive output (down to a minimum of -7V) and provides up to 100mA. The gate-driver power supplies consist of regulated charge pumps that generate +28V (DGVDD) and -21.5V (DGVEE) and can deliver up to 10mA each, depending on the POS setting. Operation at 430kHz and 2.2MHz is possible.

The LED driver section demonstrates a step-up DC-DC pre-regulator followed by four channels of linear current sinks. The step-up pre-regulator switches at 2.2MHz or 440kHz and operates as a current-mode controlled regulator capable of providing up to 600mA for the current sinks. Each channel can operate up to 48V and provides up to 150mA.

The LED driver portion of the EV kit operates from a DC supply voltage of 4.5V up to the High-Brightness (HB) LED string-forward voltage. The EV kit can withstand a 52V load-dump condition. The EV kit also demonstrates the IC's features, such as adaptive voltage optimization, Overvoltage and Undervoltage protection, cycle-by-cycle current limit, thermal shutdown, and digital PWM dimming operation using a digital PWM input signal to control the brightness of the HB LEDs.

The EV kit provides an I<sup>2</sup>C interface that can operate in conjunction with the MINIQUSB+ adapter board or a third-party I<sup>2</sup>C master. The EV kit also includes Windows®-compatible software that provides a simple graphical user interface (GUI) for exercising the features of the IC.

*Windows is a registered trademark and registered service mark of Microsoft Corporation.*

### Benefits and Features

- Demonstrates Robustness of MAX25530
- 2.8V to 5.5V Input Range for TFT Power Section
- 4.5V to 42V Input Range for LED Driver Section
- 2.2MHz or 430kHz I<sup>2</sup>C programmable Boost and Inverted Buck-Boost Switching Frequency with Spread-Spectrum Option on TFT Power Section
- 2.2MHz or 440kHz I<sup>2</sup>C programmable Boost Frequency with Spread-Spectrum Option on LED Driver Section with four 150mA LED drivers
- TFT Section Default Output Voltages (Stand-alone Mode)
  - +6V Output at 120mA (Step-Up Switching Regulator)
  - -6V Output at 100mA (Inverting Buck-Boost Switching Regulator)
  - +16V Output at 10mA (Positive-Charge Pump)
  - -7V Output at 10mA (Negative-Charge Pump)
- HB LED String Output Currents Configurable for 20mA, 50mA, 100mA, 120mA or 150mA
- Flexible Resistor-Programmable TFT Output Sequencing (Stand-alone Mode)
- Demonstrates Cycle-by-Cycle Current-Limit and Thermal-Shutdown Features on Boost LED Driver
- Demonstrates Adaptive Voltage Optimization on LED Driver Section
- I<sup>2</sup>C Programmability
- Dedicated GUI
- Proven PCB Layout and Thermal Design
- Fully Assembled and Tested

### MAX25530 EV Kit Files

FILE	DESCRIPTION
MAX25530GUISetupV01.exe	Windows GUI Installer

*[Ordering Information](#) appears at end of data sheet.*

## Quick Start

### Required Equipment

- MAX25530 EV kit
- 2.8 to 5.5V, 2A DC power supply
- 5V to 36V, 4A DC power supply
- Two digital voltmeters (DVMs)
- Four series-connected HB LED strings (6 LEDs each) rated to no less than 150mA
- Current probe to measure the HB LED current
- MINIQUSB+ interface board with USB cable
- Windows-compatible PC with a spare USB port

### Procedure

The EV kit is fully assembled and tested. Follow the steps to verify the board operation.

**Caution: Do not turn on the power supply until all connections are completed.**

### Stand-alone Mode

- 1) Verify that the jumper J1 is closed (DS1 green LED connected).
- 2) Verify that the jumper J9 is closed (FAULT signaling enabled).
- 3) Verify that the jumper J23 is open (device enabled).
- 4) Verify that the jumper J19 is closed (Buck-Boost Converter Input connected to TFT\_POWER\_INPUT PCB pad).
- 5) Verify that the jumpers J10, J11, J21 are open (FBP, FBPG, FBNG feedback Inputs enabled).
- 6) Verify that jumpers the JMP1-JMP4 have shunts installed across pins 1-2 (bleed resistors connected, all current sinks enabled).
- 7) Verify that jumper I<sup>2</sup>C is open and that jumper J2 is closed (SEQ pin connected to GND through R1 = 10k $\Omega$  resistor).
- 8) Verify that a shunt is installed across pins 2-3 on the jumper J12 (BATT pin connected to BATT PCB pad).
- 9) Verify that the jumper 100mA is closed.
- 10) Connect the positive terminal of the 2.8V to 5.5V, 2A DC power supply to the TFT\_POWER\_INPUT PCB pad. Connect the negative terminal of the power supply to a PGND PCB pad.
- 11) Connect the positive terminal of the 5V to 36V, 4A DC power supply to the BATT PCB pad. Connect the negative terminal of the power supply to a PGND PCB pad.
- 12) Connect a DVM across the OUT1 and AGND PCB pads.
- 13) Connect a DVM across one of the TFT output pads (POS, NEG, DGVDD, DGVEE) and one AGND pad.
- 14) Connect the four LED strings from VBOOST to the OUT1, OUT2, OUT3 and OUT4 PCB pads.
- 15) Clip the current probe across the channel 1 HB LED wire to measure the LED current.
- 16) Turn on the 2.8V to 5.5V, 2A DC power supply and set it to 3.3V. The green LED (DS1) should be on at this point.
- 17) Turn on the 5V to 36V, 4A DC power supply and set it to 12V. The LED strings should be on at this point.
- 18) Verify the presence of the following default TFT voltages: POS = - NEG = 6V; DGVDD = 16V; DGVEE = -7V.
- 19) Measure the voltage from each of the OUT\_ PCB pads to PGND and verify the lowest voltage is approximately 1V.
- 20) Measure the LED current using the current probe and verify all the channels.

## I<sup>2</sup>C Mode

- 1) Visit [www.maximintegrated.com/evkitsoftware](http://www.maximintegrated.com/evkitsoftware) to download the latest version of the EV kit software, MAX25530GUISetupV01.exe.
- 2) Install the EV kit software (GUI) on your PC by running the MAX25530GUISetupV01.exe program. The EV kit software application will be installed together with the required MINIQUSB+ drivers.
- 3) Verify that the jumper J1 is closed (DS1 green LED connected).
- 4) Verify that the jumper J9 is closed (FAULT signaling enabled).
- 5) Verify that the jumper J23 is closed (EN pin grounded, device to be enabled via I<sup>2</sup>C).
- 6) Verify that the jumper J19 is closed (Buck-Boost Converter Input connected to TFT\_POWER\_INPUT PCB pad).
- 7) Verify that the jumpers J10, J11, J21 are closed (FBP, FBPG, FBNG feedback Inputs grounded).
- 8) Verify that the jumpers JMP1-JMP4 have shunts installed across pins 1-2 (bleed resistors connected, all current sinks enabled).
- 9) Verify that the jumper I<sup>2</sup>C is closed and that jumpers J2-J8 are open (SEQ pin connected to TFT\_POWER\_INPUT PCB pad).
- 10) Verify that a shunt is installed across pins 2-3 on the jumper J12 (BATT pin connected to BATT PCB pad).
- 11) Verify that a shunt is installed either on the jumper ADD0 or on the jumper ADD1.
- 12) Verify that the jumper 100mA is closed.
- 13) Connect the MINIQUSB+ interface board's P3 header to the J24 header on the EV kit.
- 14) Connect the positive terminal of the 2.8V to 5.5V, 2A DC power supply to the TFT\_POWER\_INPUT PCB pad. Connect the negative terminal of the power supply to a PGND PCB pad.
- 15) Connect the positive terminal of the 5V to 36V, 4A DC power supply to the BATT PCB pad. Connect the negative terminal of the power supply to a PGND PCB pad.
- 16) Connect a DVM across the OUT1 and AGND PCB pads.
- 17) Connect a DVM across one of the TFT output PCB pads (POS, NEG, DGVDD, DGVEE) and the AGND PCB pad.
- 18) Connect the four LED strings from VBOOST to the OUT1, OUT2, OUT3, and OUT4 PCB pads.
- 19) Clip the current probe across the channel 1 HB LED wire to measure the LED current.
- 20) Turn on the 2.8V to 5.5V, 2A DC power supply and set it to 3.3V. The green LED (DS1) should be on at this point.
- 21) Turn on the 5V to 36V, 4A DC power supply and set it to 12V.
- 22) Launch the EV kit software application.
- 23) From the EV kit software toolbar, select **Device** → **Scan for Address**. The GUI scans the I<sup>2</sup>C bus for available slave addresses on the bus and selects the first option (in this case, the MAX25530 I<sup>2</sup>C address). Press **OK** once the MAX25530 I<sup>2</sup>C address has been found.
- 24) Verify that the status bar in the bottom-right corner of the GUI displays **EV Kit: Connected**, as shown in [Figure 1](#).
- 25) In the 0x02 ENABLE register group box, check ENBST, ENPOS, ENNEG, ENGVDD, ENGVEE, ENBLIGHT to activate the TFT Power Section and LED Driver Section.
- 26) Verify the presence of the following default TFT voltages: POS = -NEG = 6V; DGVDD = 8V; DGVEE = -6V.
- 27) Measure the voltage from each of the OUT\_ PCB pads to PGND and verify the lowest voltage is approximately 1V.
- 28) Measure the LED current using the current probe and verify all the channels.
- 29) For more details on how to use the GUI and all the features available, click on the GUI Help menu item.

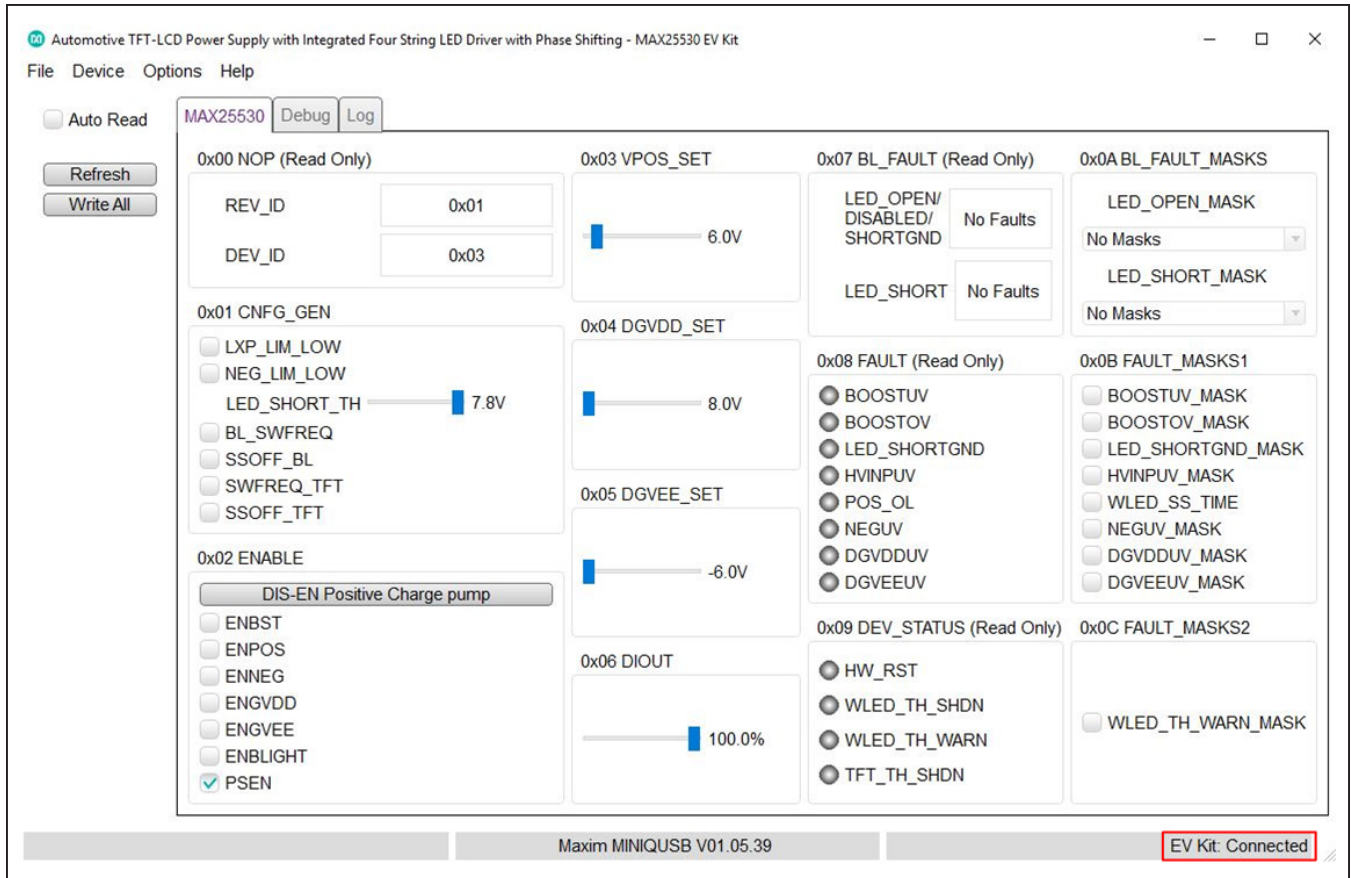

Figure 1. MAX25530 Evaluation Kit Software (GUI)

### Detailed Description of Hardware (or Software)

The EV kit consists of two sections with separate power supply inputs.

The [TFT Power Section](#) operates from a DC supply voltage of 2.8V up to 5.5V.

The [HB LED Driver Section](#) operates from a DC supply voltage of 4.5V up to the HB LED forward-string voltage and can handle load-dump conditions up to 52V.

### TFT Power Section

The EV kit TFT power section feature two source-driver power supplies ( $V_{POS}$  and  $V_{NEG}$  accessible through the POS and NEG PCB pads on the EV kit) and the two gate-driver power supplies (DGVDD and DGVEE accessible through the DGVDD and DGVEE PCB pads on the EV kit).

The source-driver power supplies consist of a synchronous boost converter and an inverting buck-boost converter that switch at 2.2MHz (or 430kHz) and can generate voltages up to +18V and down to -7V. The positive source driver can deliver up to 120mA, while the negative source driver is capable of 100mA.

The gate-driver power supplies consist of regulated charge pumps that generate up to +28V and down to -21.5V and can deliver up to 10mA each.

Select the value of the boost inductor using [Table 1](#):

**Table 1. Boost Converter Inductor Selection**

$f_{sw}$	$V_{POS} < 10V$	$V_{POS} > 10V$
430kHz	4.7 $\mu$ H	10 $\mu$ H
2.2MHz	1 $\mu$ H*	2.2 $\mu$ H

\*Default value.

### Source-Driver Output-Voltage Selection

The EV kit’s step-up switching-regulator output (POS) is set by feedback resistors R19 and R22 in a stand-alone mode with the jumper J10 open. The default output voltage is set to 6V. To generate output voltages other than 6V the user must select different external voltage-divider resistors for R19 and R22. The negative source-driver supply voltage (NEG) is automatically tightly regulated to -POS within ±50mV when jumper J19 is closed. NEG cannot be adjusted independently of POS and will be automatically shut down in case POS is set to a value higher than 7V in a stand-alone mode.

When jumper J10 is closed, the device should be operated in I<sup>2</sup>C mode. In I<sup>2</sup>C mode, POS and NEG voltages are enabled by checking **ENBST**, **ENPOS** and **ENNEG** in the **0x02 ENABLE** register group box. The POS voltage can then be regulated between 5V and 18V in 0.1V steps by acting on the 0x03 VPOS\_SET slider bar while the NEG voltage will be again regulated to -POS within ±50mV. See [Table 2](#) for J10 and J19 jumper settings.

**Note:** When POS is set to a voltage greater than 7V in I<sup>2</sup>C mode, the NEG converter should be disabled to avoid damage to the device.

Refer to the *Source-Driver Power Supplies* section in the MAX25530 IC data sheet for more information.

### Gate-Driver Output-Voltage Selection

The EV kit’s positive gate-driver power supply (DGVDD) is set to +16V by feedback resistors R23 and R20 in stand-alone mode with jumper J21 open. To generate

output voltages other than 16V, select different external voltage-divider resistors for R23 and R20. The negative gate-driver power supply (DGVEE) is set to -7V by feedback resistors R21 and R24 in stand-alone mode with jumper J11 open. To generate output voltages other than -7V, select different external voltage-divider resistors for R21 and R24.

When jumpers J11 and J21 are closed, the device should be operated in I<sup>2</sup>C mode. In I<sup>2</sup>C mode, DGVDD and DGVEE voltages are enabled by checking **ENBST**, **ENPOS**, **ENGVD**, and **ENGVEE** in the **0x02 ENABLE** register group box. The DGVDD and DGVEE voltages can then be regulated between 8V and 28V and between -6V and -21.5V respectively in 0.5V steps by acting on the **0x04 DGVDD\_SET** and **0x05 DGVEE\_SET** slider bars. See [Table 3](#) for J11 and J21 jumper settings.

Refer to the *Gate-Driver Power Supplies* section in the MAX25530 IC data sheet for more information.

### TFT Output Sequencing Control (Stand-alone mode only)

Source-driver and gate-driver outputs’ power-up and power-off is controlled by the resistor value on the SEQ pin in a stand-alone mode. When the EN pin is taken high (jumper J23 closed), the power-up sequence can be decided by connecting one of the R1–R3, R5–R7, or R18 resistors to ground through jumpers J2 to J8 (see [Table 4](#) for jumper settings).

Refer to the *Output Sequencing Control* section in the MAX25530 IC data sheet for more information.

**Table 2. POS and NEG voltage setting (J10 and J19)**

SHUNT POSITION		FBP PIN	EVKIT OPERATION
J10	J19		
Open*	Closed*	Connected at mid-point between the resistors R19 and R22	POS and -NEG voltages set to 6V in stand-alone mode
Closed	Closed	Connected to ground	POS and -NEG voltages set through I <sup>2</sup> C registers

\*Default position.

**Table 3. DGVDD and DGVEE voltage setting (J11 and J21)**

SHUNT POSITION		FBPG PIN	FBNG PIN	EVKIT OPERATION
J11	J21			
Open*	Open*	Connected at mid-point between the resistors R23 and R20	Connected at mid-point between resistors R21 and R24	DGVDD and DGVEE voltages set to 16V and -7V respectively in stand-alone mode
Closed	Closed	Connected to ground	Connected to ground	DGVDD and DGVEE voltages set through I <sup>2</sup> C registers

\*Default position.



**Table 4. TFT Output sequencing Control (J2 to J8)**

SHUNT POSITION		POWER-ON SUPPLY SEQUENCING (FROM THE EXPIRATION OF SOFT-START PERIOD)				POWER-OFF SUPPLY SEQUENCING (FROM THE INSTANT WHEN EN IS DRIVEN LOW)			
	SEQ PIN RESISTOR (kΩ ±1%)	1st AFTER 15ms	2nd AFTER 30ms	3rd AFTER 45ms	4th AFTER 60ms	1st AFTER 15ms	2nd AFTER 30ms	3rd AFTER 45ms	4th AFTER 60ms
J2 closed*	10	POS	NEG	DGVEE	DGVDD	DGVDD	DGVEE	NEG	POS
J3 closed	30	POS	NEG	DGVDD	DGVEE	DGVEE	DGVDD	NEG	POS
J4 closed	51	NEG	POS	DGVEE	DGVDD	DGVDD	DGVEE	POS	NEG
J5 closed	68	POS	DGVEE	DGVDD	No NEG output	DGVDD	DGVEE	POS	No NEG output
J6 closed	91	POS	DGVDD	DGVEE	No NEG output	DGVEE	DGVDD	POS	No NEG output
J7 closed	110	POS NEG	–	–	DGVDD DGVEE	DGVDD DGVEE	–	–	POS NEG
J8 closed	150	DGVEE	DGVDD	NEG	POS	POS	NEG	DGVDD	DGVEE

\*Default position.

## HB LED Driver Section

The EV kit LED driver section demonstrates the MAX25530 HB LED driver with an integrated step-up DC-DC pre-regulator followed by four channels of linear current sinks. The pre-regulator switches at 2.2MHz (or at 440kHz) and operates as a current-mode-controlled regulator, providing up to 600mA for the current sinks while providing power-voltage protection (OVP). Cycle-by-cycle current limit is set by the resistors R33 and R34, while the resistors R31 and R32 set the OVP voltage to 29V. The pre-regulator power section consists of inductor L3, power-sense resistors R33 and R34, Q3 MOSFET and switching diode D7.

Each of the four linear channels (OUT1–OUT4) is capable of operating up to 48V and sinks up to 150mA per channel. Each of the four channels' linear current sinks are configurable for 20mA, 50mA, 100mA, 120mA or 150mA, or can be disabled independently by connecting the respective OUT\_ channel to ground through a 12kΩ resistor before power-up with the LED string connected to the corresponding OUT\_ channel removed. Resistors R8–R12 and jumpers 50mA, 100mA, 120mA, and 150mA configure the linear current setting for the IC's ISET pin, which sets the HB LED string current.

The EV kit feature PCB pads to facilitate connecting HB LED strings for evaluation. The VBOOST PCB pads provide connections for connecting each HB LED string's anode to the DC-DC pre-regulator output. The OUT1–

OUT4 PCB pads provide connections for connecting each HB LED string's cathode to the respective current sink. Capacitors C23, and C40–C42 are included on the design to prevent oscillations and provide stability when using long, untwisted HB LED connecting cables during lab evaluation. These capacitors are not required if the connection between the LED driver and the HB LEDs is a low-inductance connection.

A DIM PCB pad is provided for using a digital PWM signal to control the brightness of the HB LEDs.

## HB LED Current

The EV kit features four jumpers (50mA, 100mA, 120mA, and 150mA) to configure the device's current sinks on all four channels. Place a shunt on one of the jumpers to configure the current-sink limits according to [Table 5](#). If no shunt is placed, the LED current will be set to 20mA. To reconfigure the circuit for another current-sink threshold, replace resistor R8, leave all the jumpers open and use the following equation to calculate a new value for the desired current:

$$I_{LED} = \frac{1500}{R_8}$$

where  $I_{LED}$  is the desired HB LED current per string in Amperes and  $R_8$  is the new resistor value for obtaining the desired HB LED current. If the HB LED current is reconfigured for a different current, other components on the EV kit may need to be modified. When I<sup>2</sup>C control is

used, the current in the strings can be reduced in steps by writing to the DIOOUT (0x06) register. The resolution of this setting is 0.5% of the value set by the resistor on ISET. Refer to the MAX25530 IC data sheet to calculate the other component values.

**Channel 1–Channel 4 Current-Sink Disabling**

The EV kit features jumpers JMP1–JMP4 which are used to put each OUT\_ current sink in one of three operating states:

- 1) Normal operation, (i.e. OUT\_ is connected to the corresponding ring on the board edge and LEDs are connected from there to the pre-regulator output V<sub>OUT</sub>).

- 2) OUT\_ connected through a 12kΩ resistor to GND and thus disabled;
- 3) OUT\_ shorted to GND, used to test fault detection.

To disable a channel, install a jumper in the channel’s respective jumper across pins 1-3, connecting the OUT\_ to ground through a 12kΩ resistor. The dimming algorithm in the IC requires that higher numbered OUT\_ current sinks be disabled first. For example, if only two strings are needed, OUT1–OUT2 should be used, with OUT3 and OUT4 disabled. See [Table 6](#) for jumper settings. The 100kΩ bleed resistors are installed to prevent the OUT\_ leakage current from dimly turning on large LED strings even when the DIM signal is low.

**Table 5. LED Current Setting (20mA, 50mA, 100mA, 120mA and 150mA)**

SHUNT POSITION	ISET RESISTOR SETTING (kΩ)	LED CURRENT SINK SETTING (mA)
Open	75	20
50mA	75  49.9 = 30	50
100mA*	75  18.7 = 15	100
120mA	75  15 = 12.5	120
150mA	75  11.5 = 10	150

\*Default position.

**Table 6. Selecting OUT\_ Channels Operating State (JMP1-JMP4)**

OUT_	JUMPER	SHUNT POSITION	CHANNEL OPERATION
OUT1	JMP4	1-2*	Channel 1 operational; connect an HB LED string** between V <sub>OUT</sub> and OUT1. Bleed resistor connected.
		1-3	Channel 1 not used. OUT1 current sink disabled.
		1-4	Channel 1 shorted to GND to simulate a fault.
OUT2	JMP3	1-2*	Channel 2 operational; connect an HB LED string** between V <sub>OUT</sub> and OUT2. Bleed resistor connected.
		1-3	Channel 2 not used. OUT2 current sink disabled.
		1-4	Channel 2 shorted to GND to simulate a fault.
OUT3	JMP2	1-2*	Channel 3 operational; connect an HB LED string** between V <sub>OUT</sub> and OUT3. Bleed resistor connected.
		1-3	Channel 3 not used. OUT3 current sink disabled.
		1-4	Channel 3 shorted to GND to simulate a fault.
OUT4	JMP1	1-2*	Channel 4 operational; connect an HB LED string** between V <sub>OUT</sub> and OUT4. Bleed resistor connected.
		1-3	Channel 4 not used. OUT4 current sink disabled.
		1-4	Channel 4 shorted to GND to simulate a fault.

\*Default position.

\*\*The series-connected HB LED string must be rated to no less than 150mA.

### HB LED Digital Dimming Control

The EV kit features a DIM PCB input pad for connecting an external digital PWM signal. Apply a digital PWM signal with a 0.8V logic-low level (or less) and 2.1V logic-high level (or greater). The DIM signal frequency should be at least 100Hz. If the DIM frequency is changed during operation, the MAX25530 must be powered off and on again to register the change. To adjust the HB LED brightness, vary the signal duty cycle from 0% to 100% and maintain a minimum pulse width of 500ns. Apply the digital PWM signal to the DIM PCB pad. The DIM input of the IC is pulled up internally with a 5µA (typ) current source.

For additional information on the device’s dimming feature, refer to the *PWM Dimming* section in the MAX25530 IC data sheet.

### Phase-Shift Operation

The EV kit demonstrates the phase-shifting feature of the IC. Phase-shift is enabled by default at each device’s power up, but it can be disabled when operating in I<sup>2</sup>C mode. To disable it, uncheck **PSEN** in the **0x02 ENABLE** register group box. This operation must be always performed before enabling any LED string.

When phase shifting is enabled, each current sink’s turn-on is separated by 360°/n, where n is the number of enabled strings. When phase shifting is disabled, the dimming of each string is controlled directly by the DIM input and all current sinks turn on and off at the same time.

### Overvoltage Detection and Protection

The resistors (R31 and R32) connected to OVP are configured for a V<sub>OUT\_OVP</sub> of 29V. This sets the maximum converter output (V<sub>BOOST</sub>) voltage at 29V. During an open-LED string condition, the converter output ramps up to the output overvoltage threshold. Capacitor C33 can be added to provide noise filtering to the overvoltage signal. To reconfigure the circuit for a different voltage, replace resistor R31 with a different value using the following equation:

$$R_{31} = R_{32} \times \left( \left( \frac{V_{OUT\_OVP}}{1.23} \right) - 1 \right)$$

Where R32 is 10kΩ, V<sub>OUT\_OVP</sub> is the overvoltage-protection threshold desired, and R31 is the new resistor value for obtaining the desired overvoltage protection. Refer to the *Open-LED Management and Overvoltage Protection (OVP)* section in the MAX25530 IC data sheet for additional information.

### SDA and SCL voltages (SDA\_PU, SCL\_PU)

SDA and SCL voltage supplies can be selected between the TFT input voltage and the fixed 3.3V provided by the MINIQUSB+ (see [Table 7](#)).

### Power LED Enable (J1)

A green LED (DS1) is used to indicate that the EV kit is powered on. The LED can be disconnected from the power supply, allowing precise current-consumption evaluation. See [Table 8](#) for shunt positions.

**Table 7. SDA and SCL supply (SDA\_PU, SCL\_PU)**

SHUNT POSITION		SDA AND SCL SUPPLY
SDA_PU	SCL_PU	
Open*	Open*	3.3V (with MINIQUSB+ connected)
Closed	Closed	TFT input voltage

\*Default position.

**Table 8. DS1 Enable (J1)**

SHUNT POSITION	DS1 POWER LED
Closed*	Connected
Open	Disconnected

\*Default position.



**Enable (EN)**

The EV kit features an enable input that can be used in stand-alone mode to enable/disable the device and place it in shutdown mode. To enable the EV kit whenever power is applied to TFT\_POWER\_INPUT PCB pad, open the jumper J23. The jumper J23 must be kept closed to disable the device in stand-alone or to operate it in I<sup>2</sup>C mode. See [Table 9](#) for J23 jumper settings.

**TFT and LED Driver Sections Switching Frequency Selection (I<sup>2</sup>C mode only)**

In I<sup>2</sup>C mode the EV kit’s step-up (POS) and buck-boost (NEG) switching-regulators frequency is selectable between 430kHz and 2.2MHz by checking/unchecking **SWFREQ\_TFT** in the **0x01 CNFG\_GEN** register group box. Similarly, the EV kit’s LED driver switching frequency is selectable between 440kHz and 2.2MHz by checking/unchecking **BL\_SWFREQ** in the **0x01 CNFG\_GEN** register group box.

Spread-spectrum can be disabled/enabled in both sections by checking/unchecking **SSOFF\_TFT** and **SSOFF\_BL** respectively in the **0x01 CNFG\_GEN** register group box.

**Note:** Switching frequency is fixed at 2.2MHz and spread-spectrum is always enabled for both sections in stand-alone mode.

**Fault-Indicator Output (FLT B)**

The EV kit features the device’s open-drain FLT B output. In I<sup>2</sup>C mode FLT B goes low when an open-LED or shorted-LED string is detected, during thermal warning/shutdown, during Boost Undervoltage/Overvoltage or during TFT rail Undervoltage events. In stand-alone mode, the FLT B signal will be continuously switching at 1kHz (typ) at different duty cycles depending on the type of fault detected.

Keep jumper J9 closed to allow DS2 red LED enabling in case FLT B goes low. Refer to the *Fault Protection* section in the MAX25530 IC data sheet for additional information on the FLT B signal.

**Table 9. Enable (J23)**

SHUNT POSITION	EN PIN	EVKIT OPERATION
Open*	Connected to TFT_POWER_INPUT	Enabled when TFT_POWER_INPUT is powered
Closed	Connected to AGND	Disabled in stand-alone mode/Operative in I <sup>2</sup> C mode

\*Default position.

**Ordering Information**

PART	TYPE
MAX25530EVKIT#	EV Kit

#Denotes RoHS compliant

MAX25530 EV Kit Bill of Materials

ITEM	REF_DES	DNI/DNP	QTY	MFG PART #	MANUFACTURER	VALUE	DESCRIPTION
1	50MA, 100MA, 120MA, 150MA, ADD0, ADD1, I2C, J1-J11, J19, J21, J23, SCL_PU, SDA_PU	—	23	PEC02SAAN	SULLINS ELECTRONICS CORP.	PEC02SAAN	EVKIT PART-CONNECTOR; MALE; THROUGH HOLE; BREAKAWAY; STRAIGHT; 2PINS;
2	AGND, AGND1, BATT, DGND, DGVDD, DGVEE, DIM, EN, FLT, HVINP, NEG, OUT1-OUT4, PGND, PGND1, PGND2, POS, SCL, SDA, TFT_POWER_INPUT, VBOOST, VBOOST1, VBOOST2	—	25	9020 BUSS	WEICO WIRE	MAXIMPAD	EVK KIT PARTS: MAXIM PAD; WIRE; NATURAL; SOLID; WEICO WIRE; SOFT DRAWN BUS TYPE-S; 20AWG
3	C1, C3, C8, C12, C25	—	5	GRM188C71E225KE11	MURATA	2.2UF	CAP; SMT (0603); 2.2UF; 10%; 25V; X7S; CERAMIC
4	C2, C4, C7	—	3	CL10B106MQ8NRN	SAMSUNG ELECTRONICS	10UF	CAP; SMT (0603); 10UF; 20%; 6.3V; X7R; CERAMIC
5	C5, C6	—	2	TMK212AB7475K; CGJ4J1X7R1E475K125AC; C2012X7R1E475K125AB; CGA4J1X7R1E475K125AC; GRM21BZ71E475KE15	TAIYO YUDEN; TDK; TDK; MURATA	4.7UF	CAP; SMT (0805); 4.7UF; 10%; 25V; X7R; CERAMIC
6	C9, C10, C15, C16, C19, C39, C43, C44	—	8	CC0603KRX7R0BB104; GRM188R72A104KA35; HMK107B7104KA; 06031C104KAT2A; GRM188R72A104K	YAGEO; MURATA; TAIYO YUDEN; AVX; MURATA	0.1UF	CAP; SMT (0603); 0.1UF; 10%; 100V; X7R; CERAMIC
7	C11	—	1	GRM188R71E105KA12; TMK107B7105KA; 06033C105KAT2A; C1608X7R1E105K080AE	MURATA; TAIYO YUDEN; AVX; TAIYO YUDEN	1UF	CAP; SMT (0603); 1UF; 10%; 25V; X7R; CERAMIC
8	C13, C18, C46	—	3	GCJ188R71H104KA12; GCM188R71H104K; CGA3E2X7R1H104K080AA; CGA3E2X7R1H104K080AD; CL10B104KB8WPN	MURATA; MURATA; TDK; TDK; SAMSUNG	0.1UF	CAP; SMT (0603); 0.1UF; 10%; 50V; X7R; CERAMIC
9	C14, C45	—	2	885012206071; C1608X7R1E104K080AA; C0603C104K3RAC; GRM188R71E104KA01; C1608X7R1E104K; 06033C104KAT2A	WURTH ELECTRONICS INC; TDK; KEMET; MURATA; TDK; AVX	0.1UF	CAP; SMT (0603); 0.1UF; 10%; 25V; X7R; CERAMIC
10	C17	—	1	GRM32ER71H106KA12; CL32B106KBJNNN; UMJ325KB7106KMH; 12105C106K4Z2A	MURATA; SAMSUNG ELECTRONICS; TAIYO YU	10UF	CAP; SMT (1210); 10UF; 10%; 50V; X7R; CERAMIC
11	C21, C24	—	2	C0603C104K8RAC	KEMET	0.1UF	CAP; SMT (0603); 0.1UF; 10%; 10V; X7R; CERAMIC
12	C22, C29	—	2	06035C101JAT	AVX	100PF	CAP; SMT (0603); 100PF; 5%; 50V; X7R; CERAMIC
13	C23, C40-C42	—	4	GRM188R72A102KA01; C1608X7R2A102K080AA	MURATA; TDK	0.001UF	CAP; SMT (0603); 0.001UF; 10%; 100V; X7R; CERAMIC
14	C26, C31	—	2	UMK107AB7105KA; CC0603KRX7R9BB105	TAIYO YUDEN; YAGEO	1UF	CAP; SMT (0603); 1UF; 10%; 50V; X7R; CERAMIC
15	C27	—	1	CGA3E1X7R0J225K080AC; GCM188R70J225KE22J	TDK; MURATA	2.2UF	CAP; SMT (0603); 2.2UF; 10%; 6.3V; X7R; CERAMIC
16	C30	—	1	C0603C473K1RAC	KEMET	0.047UF	CAP; SMT (0603); 0.047UF; 10%; 100V; X7R; CERAMIC
17	C32	—	1	MKA50V47RMH10TP	UNITED CHEM-CON	47UF	CAP; SMT (CASE_F); 47UF; 20%; 50V; ALUMINUM-ELECTROLYTIC

MAX25530 EV Kit Bill of Materials (continued)

ITEM	REF_DES	DNI/DNP	QTY	MFG PART #	MANUFACTURER	VALUE	DESCRIPTION
18	C34	—	1	C0603C104K5RAC; C1608X7R1H104K; ECJ-1VB1H104K; GRM188R71H104KA93; CGJ3E2X7R1H104K080AA; C1608X7R1H104K080AA; CL10B104KB8NNN; CL10B104KB8NFN; 06035C104KAT2A	KEMET;TDK; PANASONIC; MURATA;TDK; TDK;SAMSUNG; SAMSUNG;AVX	0.1UF	CAP; SMT (0603); 0.1UF; 10%; 50V; X7R; CERAMIC;
19	C35	—	1	CC0603KRX7R6BB224	YAGEO	0.22UF	CAP; SMT (0603); 0.22UF; 10%; 10V; X7R; CERAMIC
20	C36, C38	—	2	CGA5L3X7R1H475K160AB; C1206C475K5RACAUTO	TDK;KEMET	4.7UF	CAP; SMT (1206); 4.7UF; 10%; 50V; X7R; CERAMIC
21	C37	—	1	50HVP56M	SUNCON	56UF	CAP; SMT; 56UF; 20%; 50V; ALUMINUM-ELECTROLYTIC
22	C47	—	1	GRM188R71E223K; 885012206067	MURATA;WURTH ELECTRONIK	0.022UF	CAP; SMT (0603); 0.022UF; 10%; 25V; X7R; CERAMIC
23	D1	—	1	CMHSH5-4	CENTRAL SEMICONDUCTOR CORP.	CMHSH5-4	DIODE; SCH; SMT (SOD-123); PIV=40V; IF=0.5A; -65 DEGC TO +125 DEGC
24	D2-D5, D8-D15	—	12	BAT760-7	DIODES INCORPORATED	BAT760-7	DIODE; SCH; SMT (SOD-323); PIV=30V; IF=5.5A; -65 DEGC TO +150 DEGC
25	D6	—	1	CMPD914	CENTRAL SEMICONDUCTOR	CMPD914	SMALL SIGNAL DIODE
26	D7	—	1	NRVBS260T3G	ON SEMICONDUCTOR	NRVBS260T3G	DIODE; SCH; SURFACE MOUNT SCHOTTKY POWER RECTIFIER; SMB; PIV=60V; IF=2A
27	DS1	—	1	LTST-C170GKT	LITE-ON ELECTRONICS INC	LTST-C170GKT	DIODE; LED; STANDARD; GREEN; SMT (0805); PIV=2.1V; IF=0.01A
28	DS2	—	1	LTST-C170EKT	LITE-ON ELECTRONICS INC	LTST-C170EKT	DIODE; LED; STANDARD; RED; SMT (0805); PIV=2.0V; IF=0.02A
29	J12	—	1	PEC03SAAN	SULLINS	PEC03SAAN	CONNECTOR; MALE; THROUGH HOLE; BREAKAWAY; STRAIGHT; 3PINS
30	J13	—	1	22-05-3081	MOLEX	22-05-3081	CONNECTOR; MALE; THROUGH HOLE; FRICTION LOCK HEADER; RIGHT ANGLE; 8PINS; 0 DEGC TO +75 DEGC
31	J24	—	1	803-87-020-20-001101	PRECI-DIP SA	803-87-020-20-001101	EVKIT PART-CONNECTOR; FEMALE; TH; DOUBLE ROW; 2.54MM; RIGHT ANGLE SOLDER TAIL; MATING PIN DIA 0.76MM; RIGHT ANGLE; 20PINS;
32	JMP1-JMP4	—	4	22-28-4043	MOLEX	22-28-4043	CONNECTOR; MALE; THROUGH HOLE; FLAT VERTICAL BREAKAWAY; STRAIGHT; 4PINS
33	L1	—	1	LPS4018-222MR	COILCRAFT	2.2UH	INDUCTOR; SMT; FERRITE; 2.2UH; 20%; 2.0A
34	L2	—	1	LPS4018-102NR	COILCRAFT	1UH	INDUCTOR; SMT; FERRITE; 1UH; 30%; 2.5A
35	L3	—	1	MSS1246-103MLB	COILCRAFT	10UH	INDUCTOR; SMT; FERRITE BOBBIN CORE; 10UH; TOL=+/-20%; 4.2A; -40 DEGC TO +85 DEGC
36	L4	—	1	XAL4020-601ME	COILCRAFT	0.60UH	INDUCTOR; SMT; CORE MATERIAL= COMPOSITE; 0.60UH; TOL=+/-20%; 11.7A
37	Q1	—	1	NVMFS5826NLT1G	ON SEMICONDUCTOR	NVMFS5826NLT1G	TRAN; POWER MOSFET; SINGLE N-CHANNEL; NCH; SO-8FL; PD-(39W); L(26A); V-(60V)
38	R1, R29, R32	—	3	CRG0603F10K	TE CONNECTIVITY	10K	RES; SMT (0603); 10K; 1%; +/-100PPM/DEGC; 0.1000W
39	R2	—	1	CRCW060330K0FK	VISHAY DALE	30K	RES; SMT (0603); 30K; 1%; +/-100PPM/DEGC; 0.1000W
40	R3	—	1	CRCW060368K0FK	VISHAY DALE	68K	RES; SMT (0603); 68K; 1%; +/-100PPM/DEGC; 0.1000W
41	R4, R35	—	2	CR0603-FX-1001ELF	BOURNS	1K	RES; SMT (0603); 1K; 1%; +/-100PPM/DEGC; 0.1000W
42	R5	—	1	CRCW060391K0FK	VISHAY DALE	91K	RES; SMT (0603); 91K; 1%; +/-100PPM/DEGC; 0.1000W
43	R6	—	1	CRCW0603110KFK	VISHAY DALE	110K	RES; SMT (0603); 110K; 1%; +/-100PPM/DEGC; 0.1000W
44	R7	—	1	ERA-3AEB154	PANASONIC	150K	RES; SMT (0603); 150K; 0.10%; +/-25PPM/DEGC; 0.1000W
45	R8	—	1	ERJ-3EK7F502	PANASONIC	75K	RES; SMT (0603); 75K; 1%; +/-100PPM/DEGC; 0.1000W
46	R9	—	1	ERJ-3EK7F1872; CRCW060318K7FK	PANASONIC;VISHAY	18.7K	RES; SMT (0603); 18.7K; 1%; +/-100PPM/DEGC; 0.1000W
47	R10	—	1	CRCW060315K0FK	VISHAY DALE	15K	RES; SMT (0603); 15K; 1%; +/-100PPM/DEGC; 0.1000W

## MAX25530 EV Kit Bill of Materials (continued)

ITEM	REF_DES	DNI/DNP	QTY	MFG PART #	MANUFACTURER	VALUE	DESCRIPTION
48	R11	—	1	RC0603FR-0711K5L	YAGEO PHYCOMP	11.5K	RES; SMT (0603); 11.5K; 1%; +/-100PPM/DEGC; 0.1000W
49	R12	—	1	CRCW060349K9FK; ERJ-3EKF4992	VISHAY DALE; PANASONIC	49.9K	RES; SMT (0603); 49.9K; 1%; +/-100PPM/DEGC; 0.1000W
50	R13-R16	—	4	CRCW060312K0FK	VISHAY DALE	12K	RES; SMT (0603); 12K; 1%; +/-100PPM/DEGC; 0.1000W
51	R17, R30	—	2	CRCW060310R0FK; MCR03EZPFX10R0; ERJ-3EKF10R0	VISHAY DALE; ROHM	10	RES; SMT (0603); 10; 1%; +/-100PPM/DEGC; 0.1000W
52	R18	—	1	ERJ-3EKF5102	PANASONIC	51K	RES; SMT (0603); 51K; 1%; +/-100PPM/DEGC; 0.1000W
53	R19	—	1	CRCW0603180KFK	VISHAY DALE	180K	RES; SMT (0603); 180K; 1%; +/-100PPM/DEGC; 0.1000W
54	R20	—	1	ERJ-3EKF1692; RC0603FR-0716K9	PANASONIC; YAGEO PHYCOMP	16.9K	RES; SMT (0603); 16.9K; 1%; +/-100PPM/DEGC; 0.1000W
55	R21, R36-R39	—	5	CRCW0603100KFK; RC0603FR-07100KL; RC0603FR-13100KL; ERJ-3EKF1003; AC0603FR-07100KL	VISHAY DALE; YAGEO; YAGEO; PANASONIC	100K	RES; SMT (0603); 100K; 1%; +/-100PPM/DEGC; 0.1000W
56	R22	—	1	CRCW060347K0FKEAHP	VISHAY DRALORIC	47K	RES; SMT (0603); 47K; 1%; +/-100PPM/DEGC; 0.2500W
57	R23	—	1	CRCW06032003FK	VISHAY DALE	200K	RES; SMT (0603); 200K; 1%; +/-100PPM/DEGC; 0.1000W
58	R24	—	1	CRCW060318K0FK	VISHAY DALE	18K	RES; SMT (0603); 18K; 1%; +/-100PPM/DEGC; 0.1000W
59	R25, R26	—	2	CRCW06031K50FK	VISHAY DALE	1.5K	RES; SMT (0603); 1.5K; 1%; +/-100PPM/DEGC; 0.1000W
60	R27	—	1	CRCW06033K74FK	VISHAY DALE	3.74K	RES; SMT (0603); 3.74K; 1%; +/-100PPM/DEGC; 0.1000W
61	R28	—	1	MCR03EZPFX2002; ERJ-3EKF2002; CR0603-FX-2002ELF; CRCW060320K0FK	ROHM; PANASONIC; BOURNS; VISHAY DALE	20K	RES; SMT (0603); 20K; 1%; +/-100PPM/DEGC; 0.1000W
62	R31	—	1	ERJ-3EKF2263	PANASONIC	226K	RES; SMT (0603); 226K; 1%; +/-100PPM/DEGC; 0.1000W
63	R33, R34	—	2	CRL1206FWR082ELF	BOURNS	0.082	RESISTOR; 1206; 0.082 OHM; 1%; 200PPM; 0.25W; THICK FILM
64	SPACER1-SPACER4	—	4	9032	KEYSTONE	9032	MACHINE FABRICATED; ROUND-THRU HOLE SPACER; NO THREAD; M3.5; 5/8IN; NYLON
65	U1	—	1	MAX25530GTL/V+	MAXIM	MAX25530GTL/V+	EVKIT PART - IC; MAX25531; PACKAGE OUTLINE DRAWING: 21-0141; LAND PATTERN DRAWING: 90-0055; PACKAGE CODE: T4066-5C TQFN40-EP
66	PCB	—	1	MAX25530	MAXIM	PCB	PCB: MAX25530
67	C20	DNP	0	GRM32ER71H106KA12; CL32B106KBJN1N; UMJ325KB7106KMH; 12105C106K4Z2A	MURATA; SAMSUNG ELECTRONICS; TAIYO YU	10UF	CAP; SMT (1210); 10UF; 10%; 50V; X7R; CERAMIC
68	C28, C33	DNP	0	N/A	N/A	OPEN	PACKAGE OUTLINE 0603 NON-POLAR CAPACITOR
<b>TOTAL</b>			<b>166</b>				

MAX25530 EV Kit Schematic Diagram

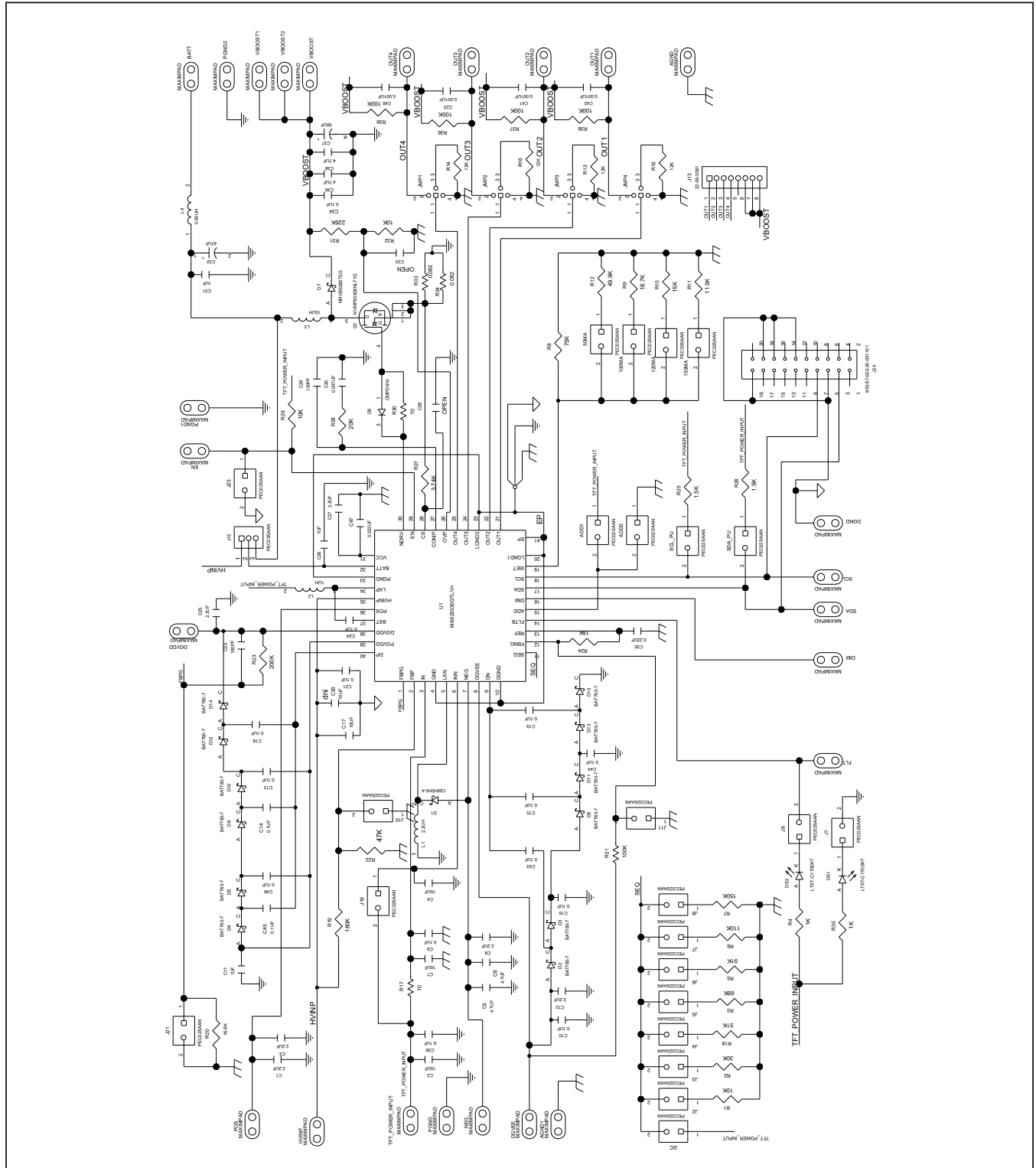



MAX25530 EV Kit PCB Layout Diagrams

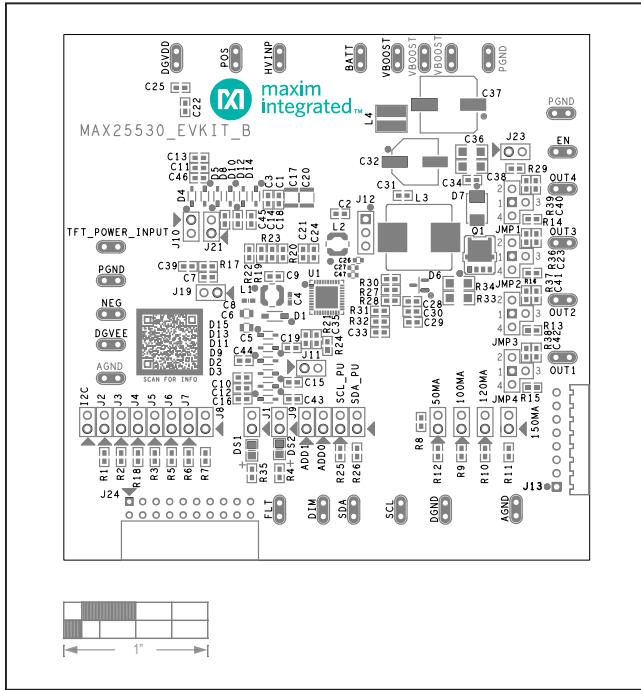

MAX25530 EV Kit Component Placement Guide—Top Silkscreen

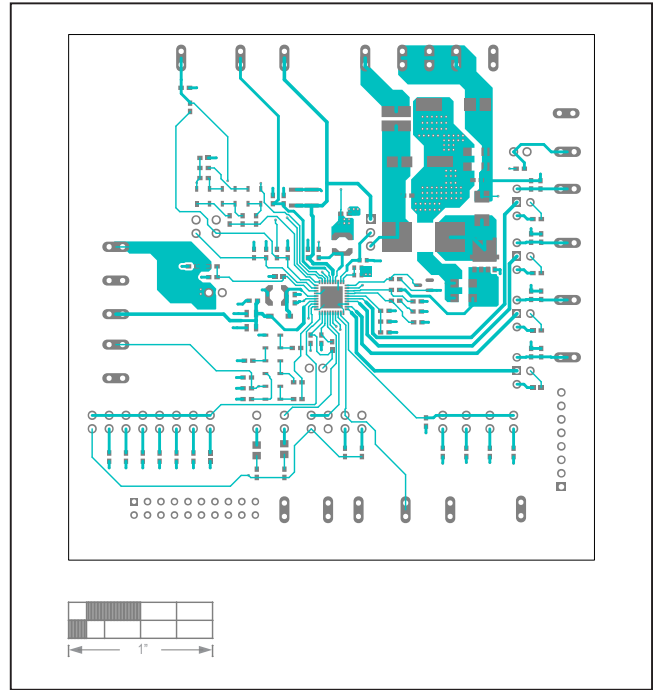

MAX25530 EV Kit PCB Layout Diagram—Top Layer

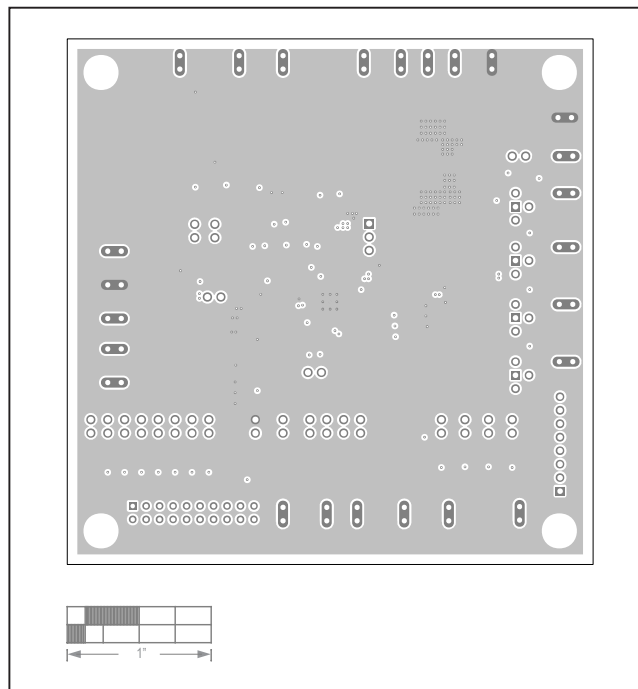

MAX25530 EV Kit PCB Layout Diagram—Internal Layer 2

MAX25530 EV Kit PCB Layout Diagrams (continued)

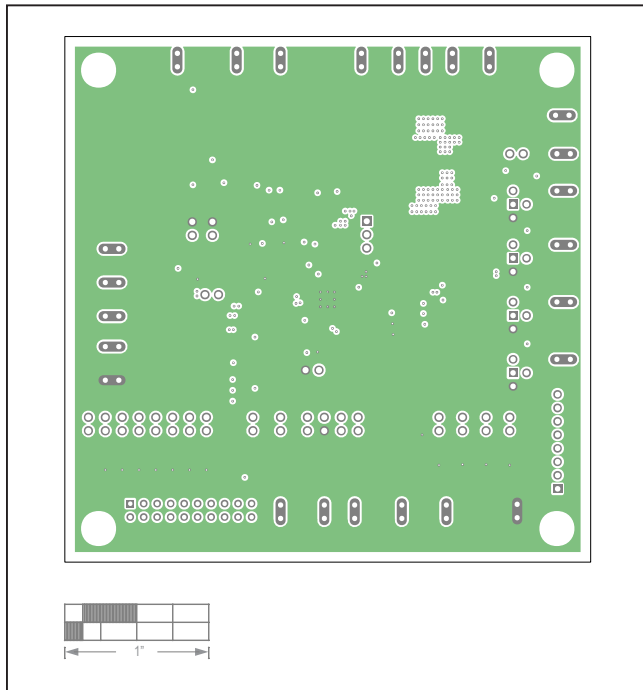

MAX25530 EV Kit PCB Layout Diagram—Internal Layer 3

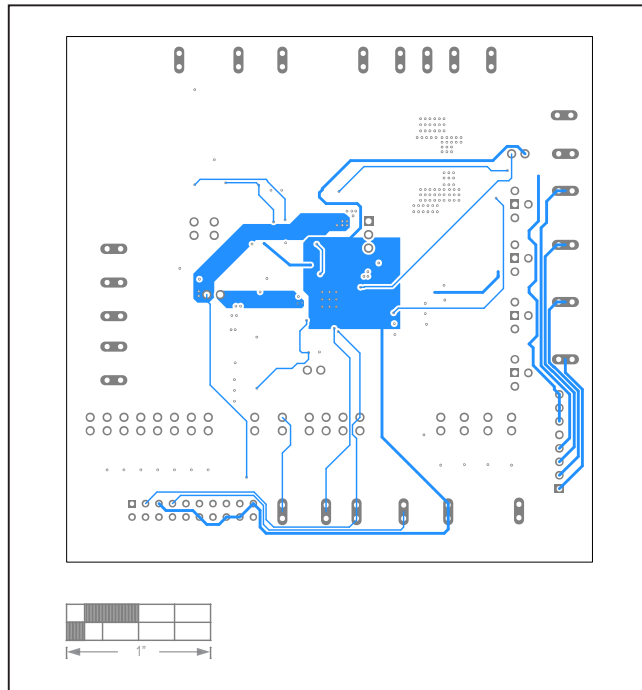

MAX25530 EV Kit PCB Layout Diagram—Bottom Layer