

MAX32625PICO Application Platform

Evaluates: MAX32625, MAX14750

General Description

The MAX32625PICO board is a rapid development platform designed to help engineers quickly implement designs with the MAX32625 ARM® Cortex®-M4 microcontroller with FPU. The board also includes the MAX14750 PMIC to provide all the needed voltages. The form factor is a small: 0.6in x 1.0in dual-row header footprint that is compatible with breadboards and can also be soldered down SMT to another board. The board includes a 10-pin ARM Cortex debug connector so that it can be used as a DAPLink adapter. Additionally, on board are an RGB indicator LED and pushbutton. This provides a power-optimized flexible platform for quick proofs-of-concept and early software development to enhance time to market.

The MAX32625PICO board ships with a DAPLink image loaded that provides the USB Mass Storage Device (MSD) drag-and-drop programming, USB Communications Device Class (CDC) virtual serial port, and Human Interface Device (HID) CMSIS-DAP interface used by the mbed site. This allows the board to be connected to another target platform to enable the full mbed experience. The microcontroller is also programmed with a bootloader allowing the DAPLink image to be updated or replaced with your own application code.

Get started developing on this board by going to this link: <http://developer.mbed.org/platforms/MAX32625PICO>.

[Ordering Information](#) appears at end of data sheet.

Benefits and Features

- Ultra-Compact Development Platform
 - 0.6in x 1.0in, 20-Pin DIP Footprint
 - Cortex Debug Connector (Host)
 - 20 Digital I/O, 4 Analog Inputs
 - 3.3V and 1.8V Supplies
- MAX326325 Microcontroller Features
 - ARM Cortex-M4 Microcontroller with FPU, 96MHz
 - 512KB Flash Memory
 - 160KB SRAM
 - 8KB Instruction Cache
 - Full-Speed USB 2.0
 - Three SPI Masters, One Slave
 - Two I²C Masters, One Slave
 - Three UARTs
 - 1-Wire Master
 - 40 GPIOs
 - Four Input 10-Bit ADC
- MAX14750 PMIC
 - Micro I_Q 3.3V Buck-Boost Regulator
 - Micro I_Q 1.8V Buck Regulators
 - Micro I_Q 1.2V Linear Regulators
 - High-Side Load Switch
- Expansion Connections
 - Breadboard-Compatible Headers
 - SMT-Compatible Footprint
 - 10-Pin Cortex Debug Header
 - Micro USB Connector
- Integrated Peripherals
 - RGB Indicator LED
 - User Pushbutton
- MAXDAP Programming Adapter
 - DAPLink Over Cortex Debug Cable
 - Drag-and-Drop Programming
 - CMSIS-DAP SWD Debugger
 - USB Virtual UART

ARM and Cortex are registered trademarks of ARM Limited (or its subsidiaries) in the EU and/or elsewhere. All rights reserved.



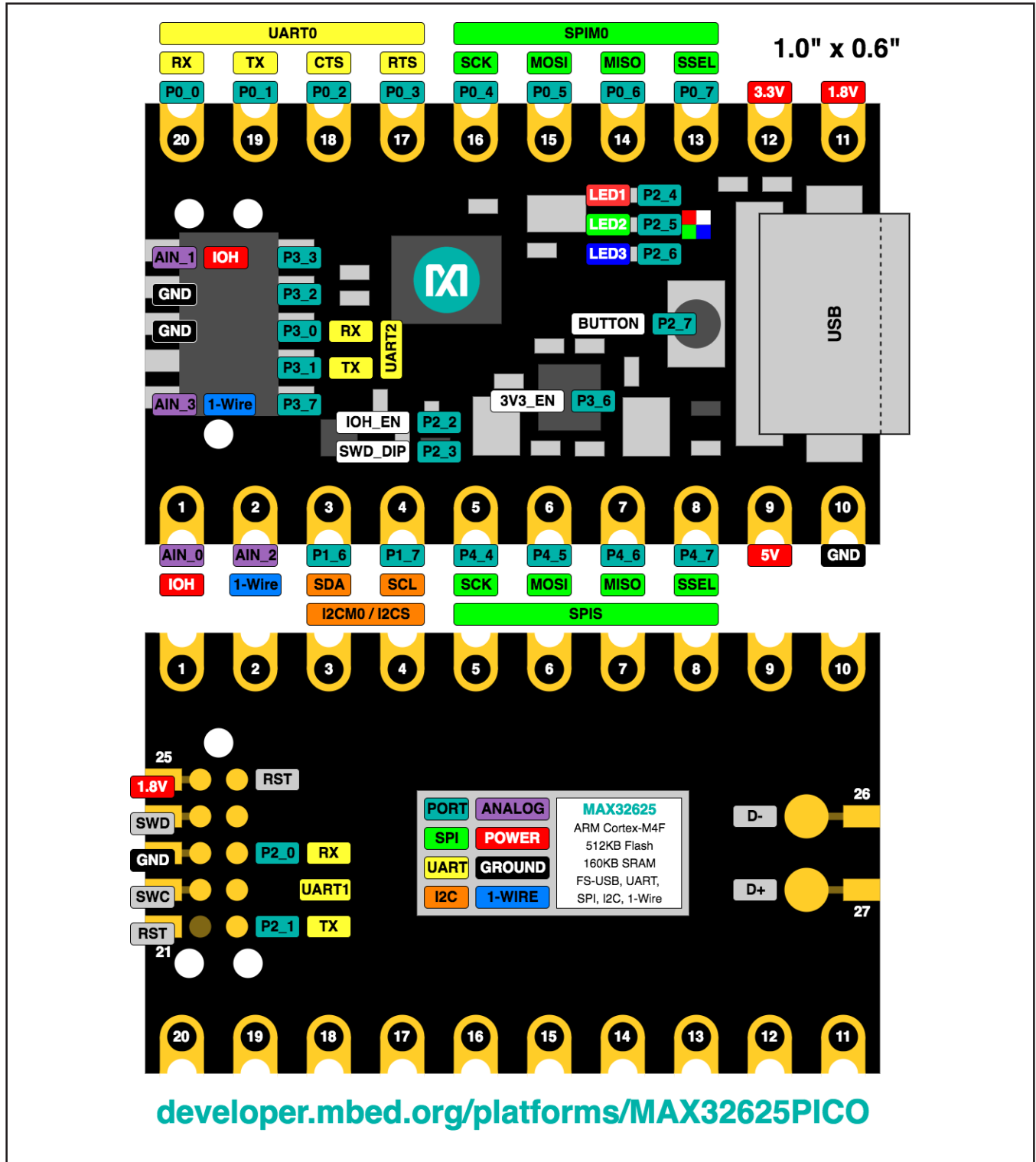

Figure 1. MAX32625 Pinout

Detailed Description

The MAX32625PICO board is a compact rapid development platform. It is a dense design that packs many features into a tight, but accessible package. It includes everything needed to run the MAX32625 from a single USB cable and provides easy access to many of the peripherals on board. In addition to a breadboard-friendly DIP expansion headers, it also includes a fine pitch 10-pin, dual-row header so that it can be cabled directly to another target with the standard 10-pin SWD header to act as a programming/debug adapter. The backside of the board has no components. The pads for the DIP pins extend to the edge of the board so that the MAX32625PICO can be soldered as a surface mount module on another board. The resources available on the MAX32625PICO board allow for the addition of a USB interface to even the most space-constrained projects.

Power Architecture

The power architecture of the MAX32625PICO board is designed to be simple and flexible. The on-board MAX14750 PMIC provides all the rails needed from a single +5V supply, which can be provided from the USB connector or the +5V pin in the DIP header. The +5V pin on the DIP header can be used as an input to power the board, or as an output from the USB VBUS supply. A diode is placed in line with the supply from USB VBUS so that the +5V pin cannot back feed the USB cable, and a resettable polyswitch fuse is placed in line with the +5V pin to limit the power into or out of the board.

The MAX14750 provides 3.3V, 1.8V, and 1.2V for the MAX32625. 3.3V and 1.8V are available at DIP header pins for powering external devices. The 3.3V supply is provided by a buck-boost regulator so the MAX32625 PICO board can operate with as little as 2.0V at the input of the PMIC.

The MAX32625 has dual I/O supply rails and all the general-purpose digital I/O ports can be set individually to use either rail. The primary VDDIO rail is supplied from the 1.8V supply, and the VDDIOH rail is connected to several analog switches so that the application can configure it to use the 3.3V supply, or DIP pin 1, or from the SWD header pin 1. This allows the board to adapt its I/O voltage to a supply provided externally.

Loading and Debugging Applications

The MAX32625 is programmed at the factory with a bootloader and DAPLink application firmware loaded so that it can be used out of the box as programming/debug adapter for other boards. The included bootloader can be enabled by holding the lone button while powering on the board.

In addition to the preinstalled bootloader, the SWD signals are available at surface pads on the back side of the board, allowing the board to be programmed or debugged with the TC2050 series of cable adapters from Tag-Connect (such as the TC2050-IDC-NL-050-ALL). The surface pads are hidden if the board is permanently mounted to another board. The suggested footprints provided for using the MAX32625PICO as a module include two options for exposing the SWD signals when mounted:

- Connect to the SWD signals with the edge pads provided.
- Add the specified cutout to the board to expose the tag-connect TC2050 footprint.

Implementing DAPLink

The MAX32625 contains all the resources needed to implement the DAPLink interface. All the signals needed are available at both the SWD header and the DIP pins. A dedicated port is provided for the SWD, UART, and reset signals at each connector. The board provides the ability to feed the target I/O supply to the VDDIOH supply input that enables support for any I/O voltage from 1.8V up to 3.6V. The VDDIOH connection is enabled and multiplexed through a MAX14689 DPDT analog switch so that the firmware can control when it is connected and which connector is selected. Additionally, the 1-Wire master is also multiplexed through the MAX14689 so that a 1-wire serial EPROM can be used to identify the target through either connector. The connectivity allows implementing the standard Cortex Debug Connector defined by ARM, as well as the additional features of the MAXDAP interface. The MAXDAP interface adds a UART and board identification capabilities to the same 10-pin Cortex SWD header while maintaining backward compatibility. The UART signals are located in place of the TDI/TDO signals and the board ID is done through the GNDDetect pin. A list of the SWD connections is provided in [Table 1](#).

Table 1. DAPLink Signals

SWD HEADER		DIP PINS		DESCRIPTION
NO.	PORT	NO.	PORT	
1	VDDIOH	1	VDDIOH	Target VCC
2	P3_3	17	P0_3	Target SWDIO
3	GND	10	GND	Ground
4	P3_2	18	P0_2	Target SWDCLK
5	GND	10	GND	Ground
6	P3_0	20	P0_0	Target Tx
7	NC	NA		Key
8	P3_1	19	P0_1	Target Rx
9	P4_0	2	P4_0	Board ID/Ground Detect
10	P3_7	16	P0_4	Target RESET

Table 2. VDDIOH/1-Wire Configuration

P3_6	P2_2	P2_3	DIP(1,2)	SWD(1,9)	VDDIOH	DESCRIPTION
0	0	X	AIN(0,2)	AIN(1,3)	Off	No VDDIOH
0	1	0	IOH,1W	AIN(1,3)	External	VDDIOH from DIP pin 1
0	1	1	AIN(0,2)	IOH,1W	External	VDDIOH from SWD pin 1
1	0	X	AIN(0,2)	AIN(1,3)	+3.3V	Onboard +3.3V
1	1	0	+3.3V,1W	AIN(1,3)	+3.3V	+3.3V out DIP pin 1
1	1	1	AIN(0,2)	+3.3V,1W	+3.3V	+3.3V out SWD pin 1

Table 3. DIP Header Pinout

PIN	NAME	DESCRIPTION
1	AIN_0	Analog Input 0. Can also be enabled as VDDIOH input/output.
2	AIN_2	Analog Input 2. Can also be enabled as 1-Wire master (P4_0).
3	P1_6	Port 1 Bit 6, I ² C Master 0 SDA
4	P1_7	Port 1 Bit 7, I ² C Master 0 SCL
5	P4_4	Port 4 Bit 4, SPI Slave SCK
6	P4_5	Port 4 Bit 5, SPI Slave MOSI
7	P4_6	Port 4 Bit 6, SPI Slave MISO
8	P4_7	Port 4 Bit 7, SPI Slave SSEL
9	5V	+5V Input/Output (up to 350mA)
10	GND	Ground
11	1.8V	+1.8V Output (up to 150mA)
12	3.3V	+3.3V Output (up to 75mA)
13	P0_7	Port 0 Bit 7, SPI Master 0 SCK

Table 3. DIP Header Pinout (continued)

PIN	NAME	DESCRIPTION
14	P0_6	Port 0 Bit 6, SPI Master 0 SSEL
15	P0_5	Port 0 Bit 5, SPI Master 0 MISO
16	P0_4	Port 0 Bit 4, SPI Master 0 MOSI
17	P0_3	Port 0 Bit 3, UART 0 RTS
18	P0_2	Port 0 Bit 2, UART 0 CTS
19	P0_1	Port 0 Bit 1, UART 0 Tx
20	P0_0	Port 0 Bit 0, UART 0 Rx

Table 4. Edge Surface Mount Contacts

PIN	NAME	DESCRIPTION
21	RST	System Reset (This pad is grounded on early units.)
22	SWC	SWD Clock
23	GND	Ground
24	SWD	SWD Data I/O
25	1.8V	+1.8V Output
26	DM	USB D- (This pad is not present on early units.)
27	DP	USB D+ (This pad is not present on early units.)

Table 5. SWD Header Pinout

PIN	NAME	DESCRIPTION
1	VIO	Analog Input 1. Can also be enabled as VDDIOH input/output.
2	DIO	Port 3 Bit 3. For SWDIO.
3	GND	Ground
4	CLK	Port 3 Bit 2. For SWDCLK.
5	GND	Ground
6	TGT_TX	Port 3 Bit 0, UART 2 Rx for Debug Console
7	N.C.	Key
8	TGT_RX	Port 3 Bit 1, UART 2 Tx for Debug Console T
9	DETECT	Analog Input 3. Can also be enabled as 1-Wire master (P4_0).
10	RST	Port 3 Bit 7. For SRST#.

Table 6. On-Board Resources

PORT	NAME	DESCRIPTION
P2_0	DBG_RX	Debug Console Rx
P2_1	DBG_TX	Debug Console Tx
P2_2	IOH_1W_EN	Enables IOH/1-Wire Mux
P2_3	SWD_DIP_SEL	Selects IOH/1-Wire between the SWD header (0) or DIP header (1)
P2_4	LED1	Red LED
P2_5	LED2	Green LED
P2_6	LED3	Blue LED
P2_7	BUTTON	Button Input. Requires internal pullup to be enabled.
P3_6	3V3_IOH_EN	Enables Power Switch Connecting +3.3V Supply to VDDIOH. Enables +3.3V I/O option and turns IOH into a +3.3V output if mux is enabled (IOH_1W_EN = 1).
P4_0	OWM_IO	1-Wire Master I/O
P4_1	OWM_PUPEN	1-Wire Master Pullup Enable

Surface Mount Footprints

The following footprints are suggestions for surface mounting the board as a module onto another board. These footprints offer two ways to provide access to debug/test signals on the MAX32625 if access is desired. Without access to the SWD signals, it might not be possible to recover a corrupted bootloader. The first footprint includes edge pads for soldering to the debug/test signals and the second footprint shows where to put cutouts for access.

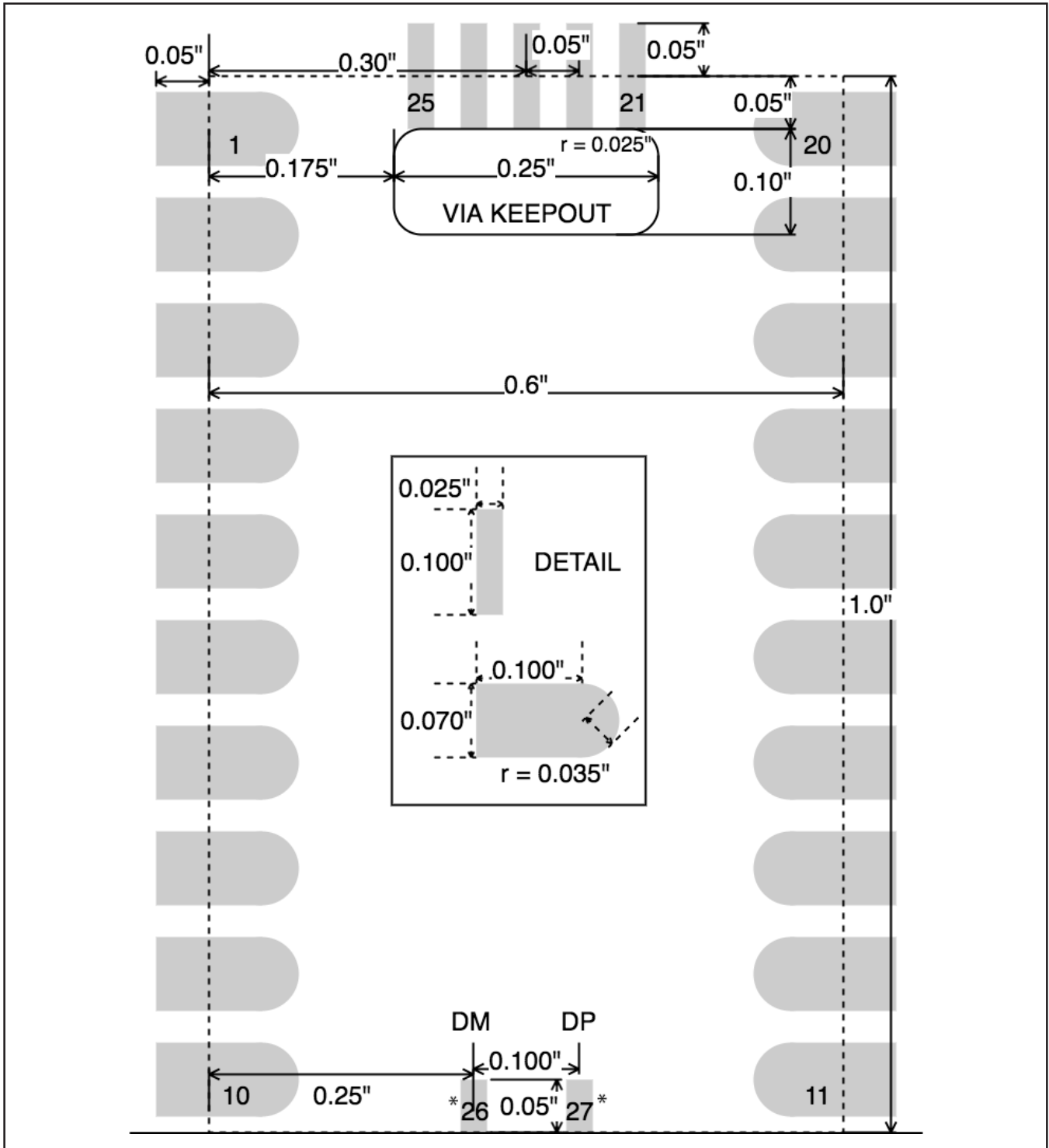

Figure 2. MAX32625PICO Surface Mount Footprint, Edge Pads

*These pads are not present on early units.

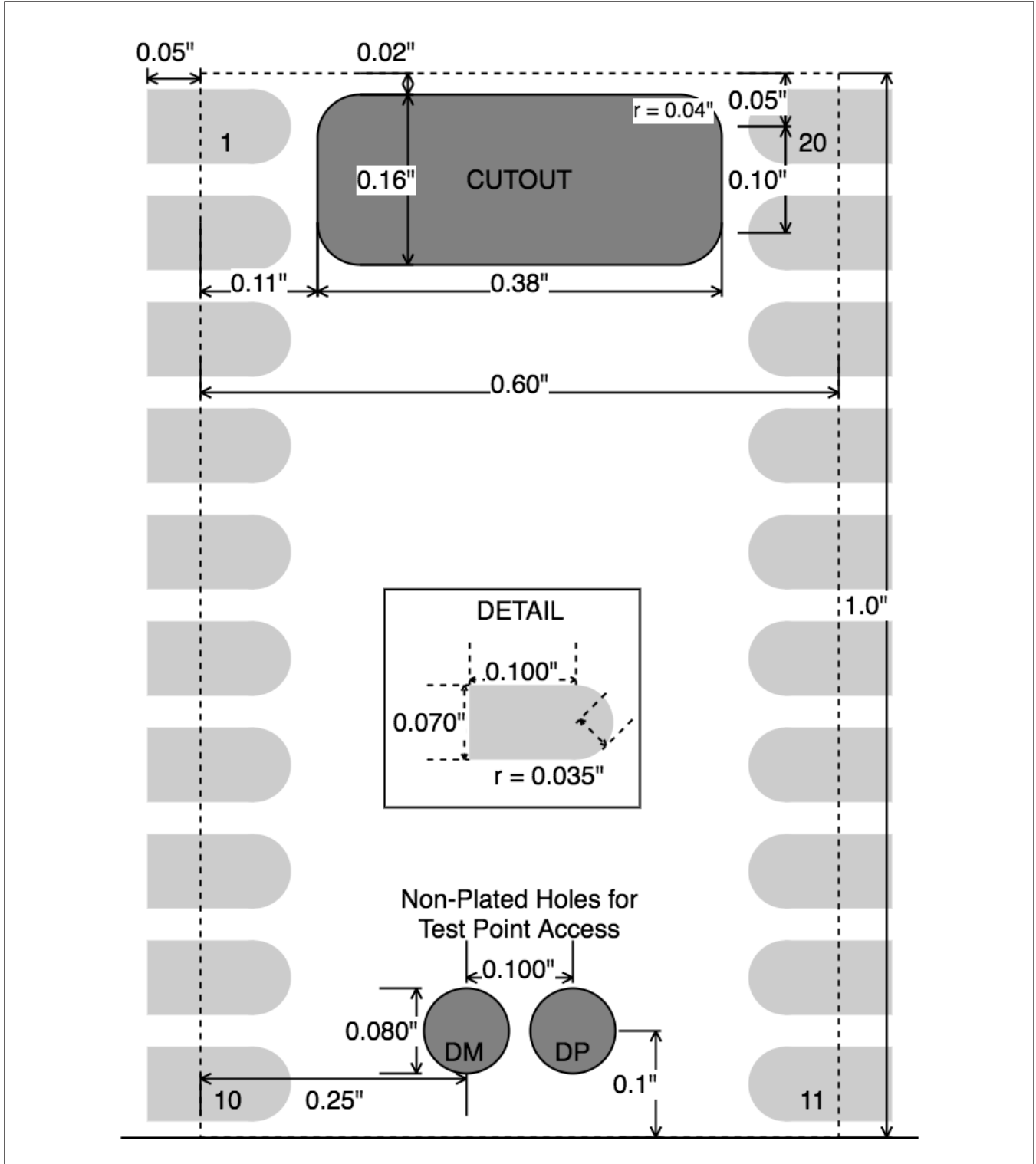
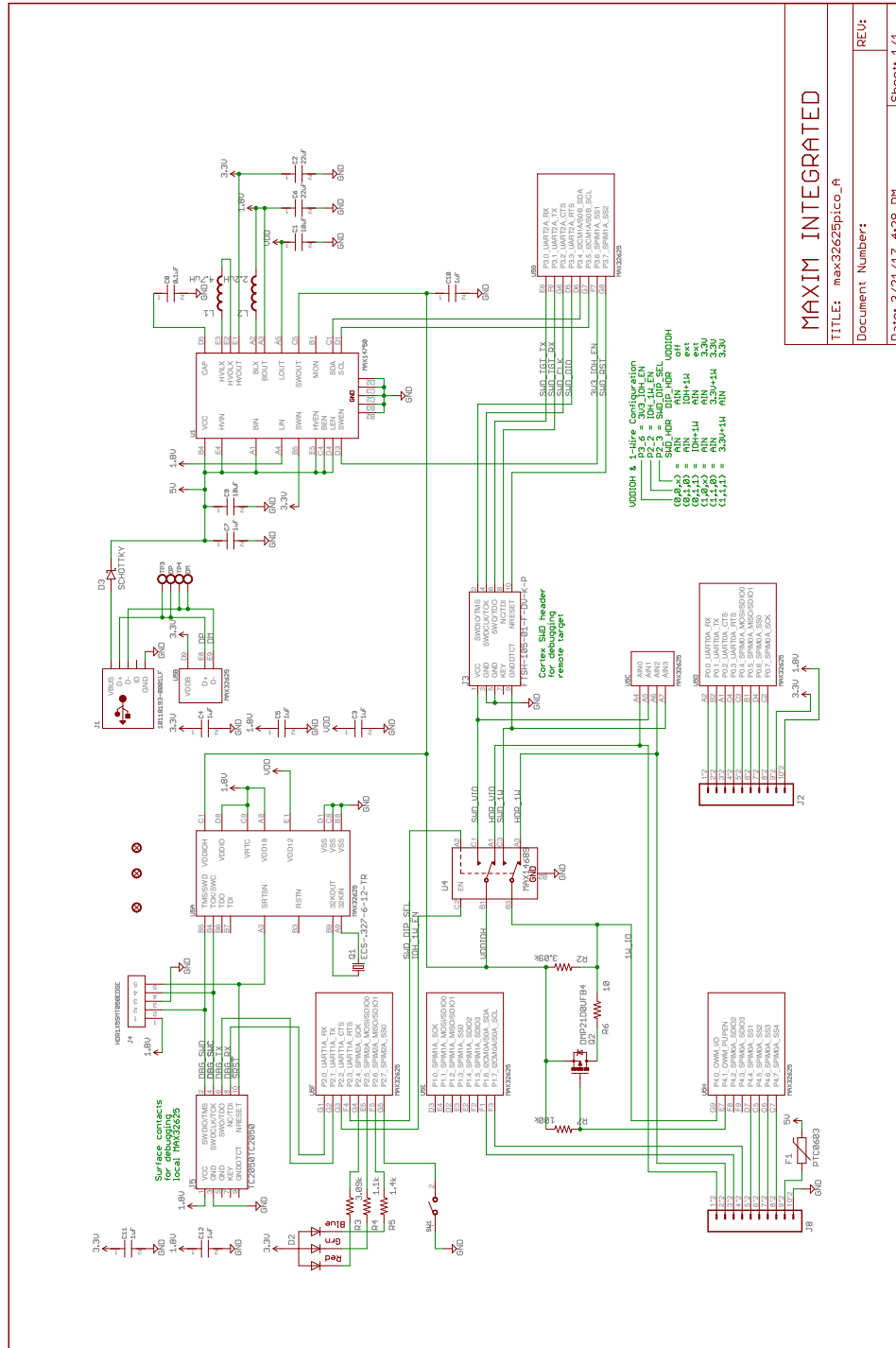

Figure 3. MAX32625PICO Surface Mount Footprint, Cutouts

MAX32625PICO EV Schematic



MAXIM INTEGRATED	
TITLE: max32625pico_1	
Document Number:	REU
Date: 3/21/17 4:28 PM	Sheet 1/1

Figure 4. MAX32625PICO Schematic

MAX32625PICO EV Bill of Materials

QTY	SCHEMATIC REFERENCE	DESCRIPTION	MANUFACTURER	MPN
2	C1, C9	Capacitors, 0402, X5R, 10V, 10µF	Samsung	CL05A106MP5NUNC
2	C2, C6	Capacitors, 0402, X5R, 6.3V, 22µF	Samsung	CL05A226MQ5QUNC
7	C3, C4, C5, C7, C10, C11, C12	Capacitors, 0402, X5R, 6.3V, 1µF	TDK	C1005X5R0J105K050BB
1	C8	Capacitor, 0402, X5R, 10V, 0.1µF	TDK	C1005X5R1A104K050BA
1	D2	RGB LED, common anode	Lumex	SML-LX0404SIUPGUSB
1	D3	Schottky diode	Panasonic	DB2G32600L1
1	F1	Resettable fuse PTC	Bourns	MF-FSMF035X-2
1	J1	CONN USB MICRO B RECPT SMT R/A	FCI	10118193-0001LF
1	J3	Cortex debug connector	Samtec	FTSH-105-01-F-DV-K-P-TR
1	L1	Inductor, 2016, 4.7µH	TDK	VLS201612CX-4R7M
1	L2	Inductor, 2016, 2.2µH	TDK	VLS201612CX-2R2M
1	Q1	32.768kHz crystal	ECS International	ECS-.327-6-12-TR
1	Q2	MOSFET, P-CH, DFN1006, 0.5Ω	Diodes Inc.	DMP21D0UFB4-7B
2	R2, R3	Resistors, thick film, 0402, 0.1W, 1%, 3.09kΩ	Panasonic	ERJ-2RKF3091X
1	R4	Resistor, thick film, 0402, 0.1W, 1%, 1.1kΩ	Panasonic	ERJ-2RKF1101X
1	R5	Resistor, thick film, 0402, 0.1W, 1%, 1.4kΩ	Panasonic	ERJ-2RKF1401X
1	R6	Resistor, thick film, 0402, 0.1W, 1%, 10Ω	Panasonic	ERJ-2RKF10R0X
1	R7	Resistor, thick film, 0402, 0.1W, 1%, 100kΩ	Panasonic	ERJ-2RKF1003X
1	SW1	SWITCH TACTILE SPST-NO 0.05A 12V	OMRON	B3U-1000P
1	U1	PMIC, MAX14750B		
1	U4	Analog switch, DPDT, MAX14689	Maxim Integrated	MAX14689EWL+T
1	U5	ARM Cortex-M4 microcontroller with FPU, MAX32625	Maxim Integrated	MAX32625IWY+

Ordering Information

PART	TYPE
MAX32625PICO#	Adapter Platform

#Denotes RoHS compliant.