

MAX3362

3.3V, High-Speed, RS-485/RS-422 Transceiver in SOT Package

General Description

The MAX3362 low-power, high-speed transceiver for RS-485/RS-422 communication operates from a single +3.3V power supply. The device contains one differential transceiver consisting of a line driver and receiver. The transceiver operates at data rates up to 20Mbps, with an output skew of less than 6ns. Driver and receiver propagation delays are guaranteed below 50ns. This fast switching and low skew make the MAX3362 ideal for multidrop clock/data distribution applications.

The output level is guaranteed at +1.5V with a standard 54Ω load, compliant with RS-485 specifications. The transceiver draws 1.7mA supply current when unloaded or fully loaded with the drivers disabled. Additionally, the MAX3362 has a low-power shutdown mode, reducing the supply current to 1μA.

The MAX3362 has a 1/8-unit-load receiver input impedance, allowing up to 256 transceivers on the bus. The MAX3362 is designed for half-duplex communication. The device has a hot-swap feature that eliminates false transitions on the data cable during circuit initialization. The drivers are short-circuit current limited, and a thermal shutdown circuit protects against excessive power dissipation.

The MAX3362 is available in an 8-pin SOT package and specified over industrial and automotive temperature ranges.

Applications

- Clock/Data Distribution
- Telecom Equipment
- Security Equipment
- Point-of-Sale Equipment
- Industrial Controls

Typical Operating Circuit

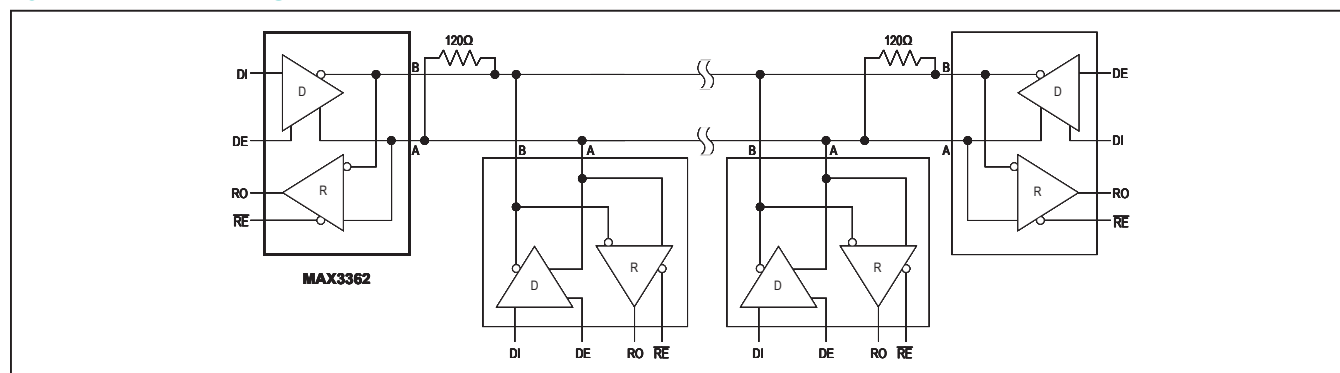

Benefits and Features

- Ideal for Multidrop RS-485/RS-422 Clock/Data Distribution
 - Guaranteed 20Mbps Data Rate
 - 6ns (max) Transmitter and Receiver Skew
 - -7V to +12V Common-Mode Range
 - Hot-Swap Feature
 - Allows Up to 256 Transceivers on the Bus
 - Half-Duplex Operation
 - Interoperable with +5V Logic
- Low Power Consumption Minimizes Thermal Dissipation
 - Operates from a Single +3.3V Supply
 - 1.7mA Operating Supply Current
 - 1μA Low-Power Shutdown Mode
- Space-Saving 8-Pin SOT Package
- Protection Features and Wide Temperature Range Increase System Reliability in Harsh Environments
 - Current Limiting and Thermal Shutdown
 - Automotive Temperature Range Variants

Ordering Information

PART	TEMP RANGE	PIN-PACKAGE
MAX3362EKA+T	-40°C to +85°C	8 SOT23-8
MAX3362AKA+T	-40°C to +125°C	8 SOT23-8

+Denotes a lead-free package

[Pin Configuration](#) and [Functional Diagram](#) appear at end of data sheet.

Absolute Maximum Ratings

All voltages with respect to GND.

V_{CC}, RE, DE, DI.....-0.3V to +6V
 Receiver Input Voltages, Driver Output
 Voltages (A, B).....-8V to +13V
 Receiver Input Current, Driver Output
 Current (A, B)250mA
 |V_A - V_B|+8V
 Receiver Output Voltage (RO) -0.3V to (V_{CC} + 0.3V)

Continuous Power Dissipation (T_A = +70°C)
 8-Pin SOT (derate 9.7mW/°C above +70°C).....777mW
 Operating Temperature Range
 MAX3362E.....-40°C to +85°C
 MAX3362A.....-40°C to +125°C
 Storage Temperature Range.....-65°C to +150°C
 Junction Temperature.....+150°C
 Lead Temperature (soldering, 10s)+300°C

Stresses beyond those listed under "Absolute Maximum Ratings" may cause permanent damage to the device. These are stress ratings only, and functional operation of the device at these or any other conditions beyond those indicated in the operational sections of the specifications is not implied. Exposure to absolute maximum rating conditions for extended periods may affect device reliability.

DC Electrical Characteristics

(V_{CC} = +3.3V ±5%, T_A = T_{MIN} to T_{MAX}, unless otherwise noted. Typical values are at V_{CC} = +3.3V and T_A = +25°C.) (Notes 1, 2)

PARAMETER	SYMBOL	CONDITIONS	MIN	TYP	MAX	UNITS
DRIVER						
Differential Driver Output	V _{OD}	Figure 1, R _L = 100Ω (RS-422) (extended temperature range)	2.0			V
		Figure 1, R _L = 100Ω (automotive temperature range)	1.5			
		Figure 1, R _L = 54Ω (RS-485) (extended temperature range)	1.5			
Change in Magnitude of Differential Output Voltage	ΔV _{OD}	Figure 1, R _L = 54Ω or 100Ω (Note 3)			0.2	V
Driver Common-Mode Output Voltage	V _{OC}	Figure 1, R _L = 54Ω or 100Ω			3	V
Change In Magnitude of Common-Mode Voltage	ΔV _{OC}	Figure 1, R _L = 54Ω or 100Ω (Note 3)			0.2	V
Input High Voltage	V _{IH}	DE, DI, RE	2.0			V
Input Low Voltage	V _{IL}	DE, DI, RE			0.8	V
Input Hysteresis	V _{HYS}	DE, DI, RE		50		mV
Input Current (DE, DI, RE)	I _{IN}	0 ≤ V _{IN} ≤ 5V			±1	μA
Driver Short-Circuit Output Current	I _{OSD}	0 ≤ V _{OUT} ≤ 12V (Note 4)			+250	mA
		-7V ≤ V _{OUT} ≤ V _{CC} (Note 4)	-250			
Driver Short-Circuit Foldback Output Current	I _{OSDF}	(V _{CC} - 1V) ≤ V _{OUT} ≤ 12V (Note 4)	+25			mA
		-7V ≤ V _{OUT} ≤ 1V (Note 4)			-25	

DC Electrical Characteristics (continued)(V_{CC} = +3.3V ±5%, T_A = T_{MIN} to T_{MAX}, unless otherwise noted. Typical values are at V_{CC} = +3.3V and T_A = +25°C.) (Notes 1, 2)

PARAMETER	SYMBOL	CONDITIONS	MIN	TYP	MAX	UNITS
Thermal Shutdown Threshold	V _{TS}			150		°C
Thermal Shutdown Hysteresis	V _{TSH}			10		°C
RECEIVER						
Receiver Differential Threshold Voltage	V _{TH}	-7V ≤ V _{CM} ≤ 12V	-200	0	+200	mV
Receiver Input Hysteresis	ΔV _{TH}	V _A + V _B = 0		25		mV
Receiver Output High Voltage	V _{OH}	I _O = -1mA, V _A - V _B = V _{TH}	V _{CC} - 0.4			V
Receiver Output Low Voltage	V _{OL}	I _O = 1mA, V _A - V _B = -V _{TH}			0.4	V
Three-State Output Current at Receiver	I _{OZR}	0 ≤ V _O ≤ V _{CC}			±1	μA
Receiver Input Resistance	R _{IN}	V _{CM} = 12V	96			kΩ
Receiver Input Current	I _{IN}	DE = GND, V _{CC} = GND or 3.465V	V _{IN} = +12V		125	μA
			V _{IN} = -7V	-100		
Receiver Output Short-Circuit Current	I _{OSR}	0 ≤ V _{RO} ≤ V _{CC}			±150	mA
POWER SUPPLY						
Supply Voltage	V _{CC}		3.135	3.300	3.465	V
Supply Current in Normal Operation (Static Condition)	I _Q	No load, DI = V _{CC} or GND		1.7	3	mA
Supply Current in Shutdown Mode	I _{SHDN}	DE = GND, \overline{RE} = V _{CC}		1	10	μA

Switching Characteristics(V_{CC} = +3.3V ±5%, T_A = T_{MIN} to T_{MAX}, unless otherwise noted. Typical values are at V_{CC} = +3.3V and T_A = +25°C.) (Note 1)

PARAMETER	SYMBOL	CONDITIONS	MIN	TYP	MAX	UNITS
Driver Propagation Delay	t _{PDLH}	Figures 2 and 3, R _L = 54Ω, C _L = 50pF			50	ns
	t _{PDHL}				50	
Driver Differential Output Rise or Fall Time	t _{DR}	Figures 2 and 3, R _L = 54Ω, C _L = 50pF			12.5	ns
	t _{DF}				12.5	
Driver Output Skew	t _{DSKEW}	Figures 2 and 3, R _L = 54Ω, C _L = 50pF t _{DSKEW} = t _{PDLH} - t _{PDHL}			6	ns
Maximum Data Rate	f _{MAX}		20			Mbps
Driver Enable to Output Low	t _{PDZL}	Figure 4, R _L = 500Ω, C _L = 50pF			100	ns
Driver Disable Time from Low	t _{PDLZ}	Figure 4, R _L = 500Ω, C _L = 50pF			100	ns
Driver Disable Time from High	t _{PDHZ}	Figure 5, R _L = 500Ω, C _L = 50pF			100	ns

Switching Characteristics (continued)

(V_{CC} = +3.3V ±5%, T_A = T_{MIN} to T_{MAX}, unless otherwise noted. Typical values are at V_{CC} = +3.3V and T_A = +25°C.) (Note 1)

PARAMETER	SYMBOL	CONDITIONS	MIN	TYP	MAX	UNITS
Driver Enable to Output High	t _{PDZH}	Figure 5, R _L = 500Ω, C _L = 50pF			100	ns
Receiver Propagation Delay	t _{PRLH}	Figure 6, C _L = 15pF			50	ns
	t _{PRHL}				50	
Receiver Output Skew	t _{RSKEW}	Figure 6, C _L = 15pF t _{RSKEW} = t _{PRLH} - t _{PRHL}			6	ns
Receiver Enable to Output Low	t _{PRZL}	Figure 7, R _L = 1kΩ, C _L = 15pF			100	ns
Receiver Enable to Output High	t _{PRZH}	Figure 7, R _L = 1kΩ, C _L = 15pF			100	ns
Receiver Disable Time from Low	t _{PRLZ}	Figure 7, R _L = 1kΩ, C _L = 15pF			100	ns
Receiver Disable Time from High	t _{PRHZ}	Figure 7, R _L = 1kΩ, C _L = 15pF			100	ns
Time to Shutdown	t _{SD}	(Note 5)	50		600	ns
Driver Enable from Output High to Shutdown	t _{PDHS}		50		600	ns
Driver Enable from Output Low to Shutdown	t _{PDLS}		50		600	ns
Receiver Enable from Output High to Shutdown	t _{PRHS}		50		600	ns
Receiver Enable from Output Low to Shutdown	t _{PRLS}		50		600	ns
Time to Normal Operation	t _{NO}	(Note 6)		1500	3000	ns
Driver Enable from Shutdown to Output High	t _{PDSH}	Figure 5 R _L = 500Ω, C _L = 50pF		1500	3000	ns
Driver Enable from Shutdown to Output Low	t _{PDSL}	Figure 4 R _L = 500Ω, C _L = 50pF		1500	3000	ns
Receiver Enable from Shutdown to Output High	t _{PRSH}	Figure 7 R _L = 1kΩ, C _L = 15pF		1500	3000	ns
Receiver Enable from Shutdown to Output Low	t _{PRSL}	Figure 7 R _L = 1kΩ, C _L = 15pF		1500	3000	ns

Note 1: Devices production tested at +25°C. Over-temperature limits are guaranteed by design.**Note 2:** All currents into the device are positive; all currents out of the device are negative. All voltages are referenced to device ground, unless otherwise noted.**Note 3:** ΔV_{OD} and ΔV_{OC} are the changes in V_{OD} and V_{OC}, respectively, when the DI input changes state.**Note 4:** The short-circuit output current applies to peak current just prior to foldback-current limiting; the short-circuit foldback output current applies during current limiting to allow a recovery from bus contention.**Note 5:** Shutdown is enabled by bringing RE high and DE low. If the enable inputs are in this state for less than 50ns, the device is guaranteed not to enter shutdown. If the enable inputs are in this state for at least 600ns, the device is guaranteed to have entered shutdown.**Note 6:** Transition time from shutdown mode to normal operation.

Typical Operating Characteristics

($V_{CC} = +3.3V$, $T_A = +25^\circ C$, unless otherwise noted.)

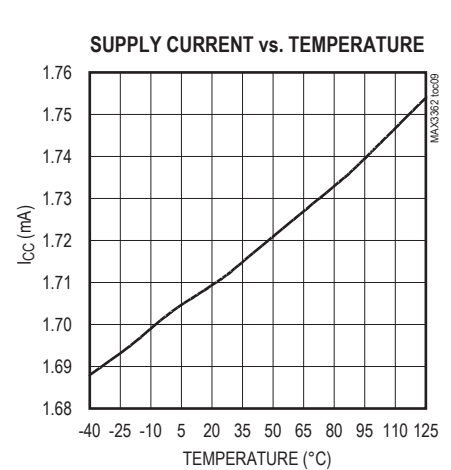
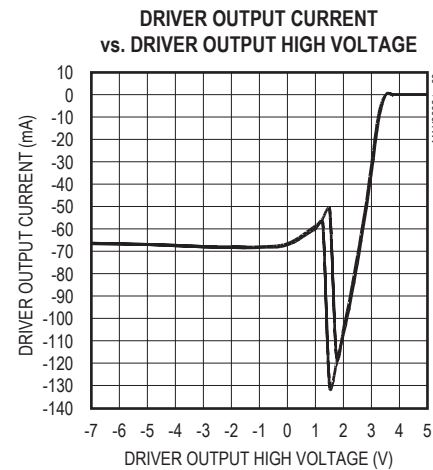
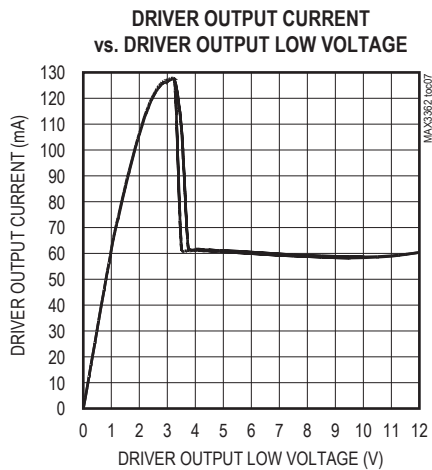
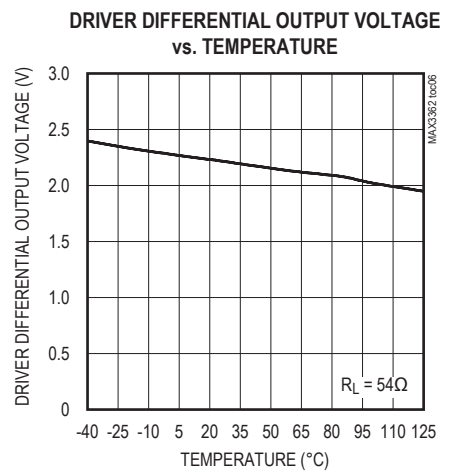
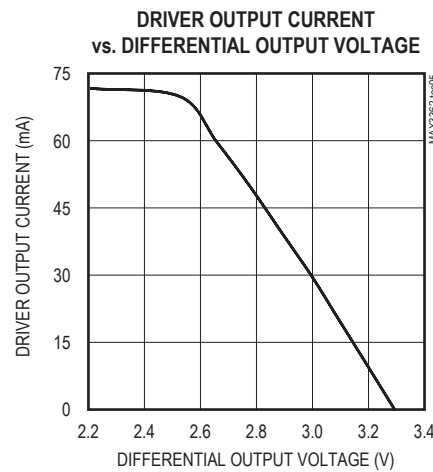
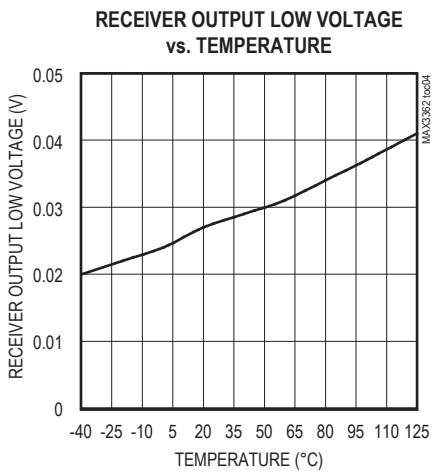
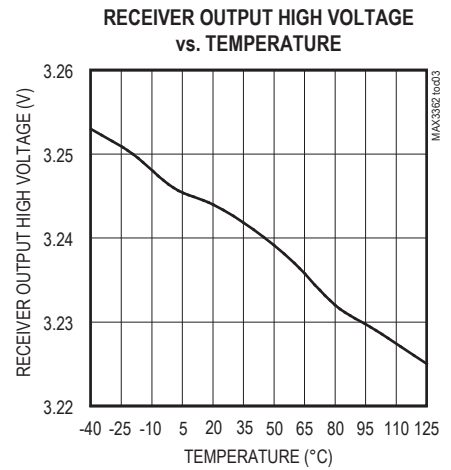
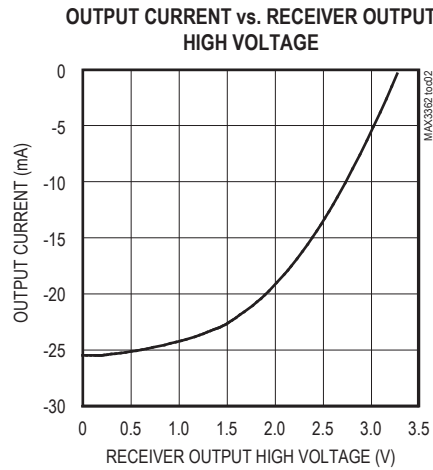
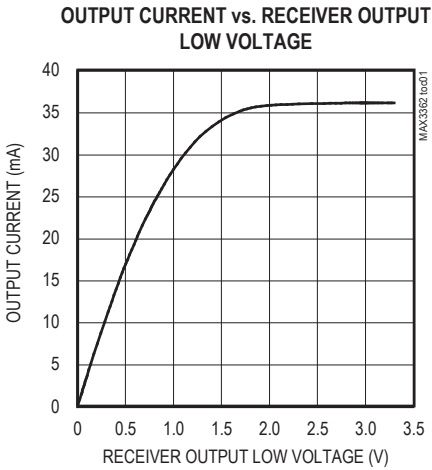

Typical Operating Characteristics (continued)

($V_{CC} = +3.3V$, $T_A = +25^\circ C$, unless otherwise noted.)

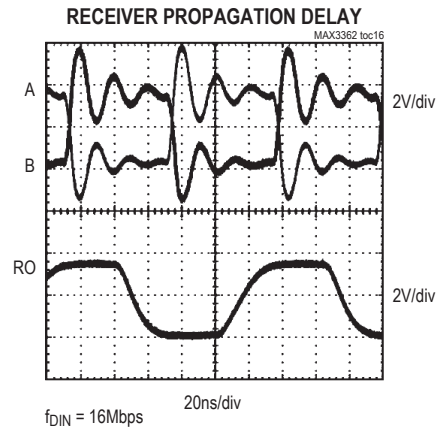
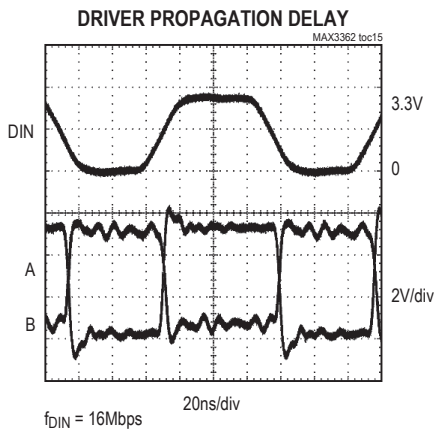
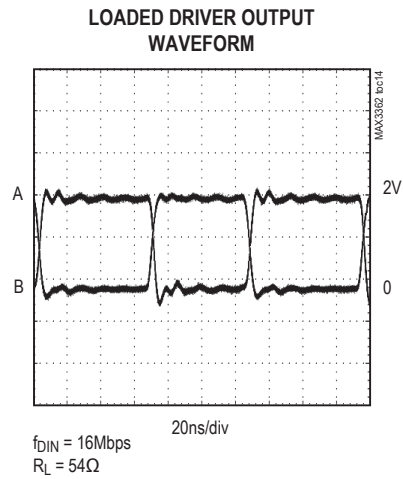
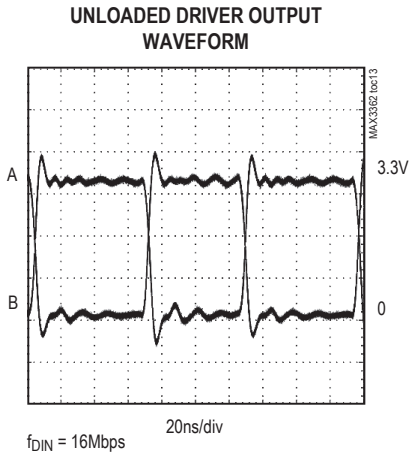
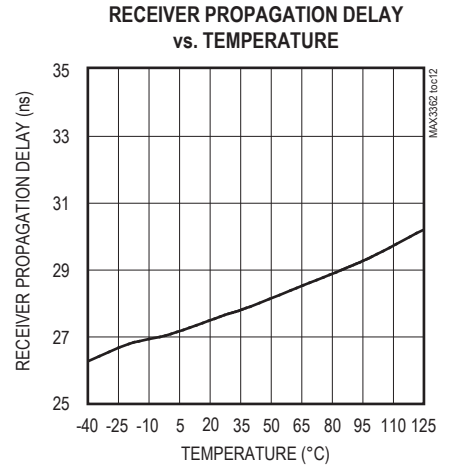
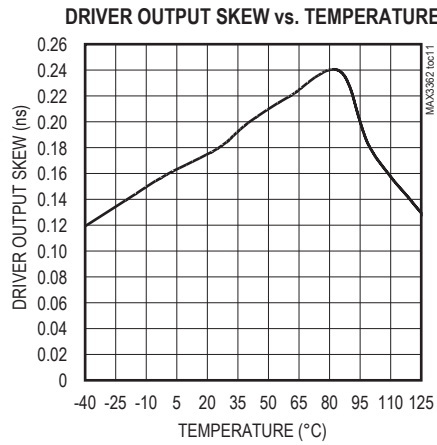
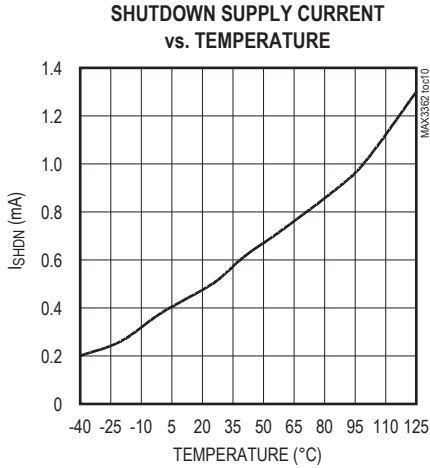

Pin Description

PIN	NAME	DESCRIPTION
1	RO	Receiver Output. RO is high if the receiver input differential (A-B) ≥ 200mV and the receiver is enabled (RE is low). RO is low if the receiver input differential (A-B) ≤ -200mV and the receiver is enabled.
2	RE	Receiver Output Enable. Driving RE low enables RO. RO is high impedance when RE is high. Drive RE high and DE low (disable both receiver and driver outputs) to enter low-power shutdown mode.
3	DE	Driver Output Enable. Driving DE high enables driver outputs. These outputs are high impedance when DE is low. Drive RE high and DE low (disable both receiver and driver outputs) to enter low-power shutdown mode.
4	DI	Driver Input. Driving DI low forces the noninverting output low and inverting output high, when the driver is enabled (DE is high). Driving DI high forces the noninverting output high and inverting output low.
5	GND	Ground
6	A	Noninverting Receiver Input and Noninverting Driver Output
7	B	Inverting Receiver Input and Inverting Driver Output
8	VCC	Supply Voltage. VCC = 3.3V ±5%. Bypass VCC to GND with a 0.1µF capacitor.

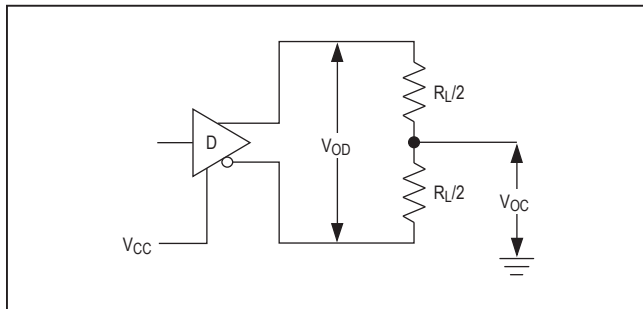

Figure 1. Driver DC Test Load

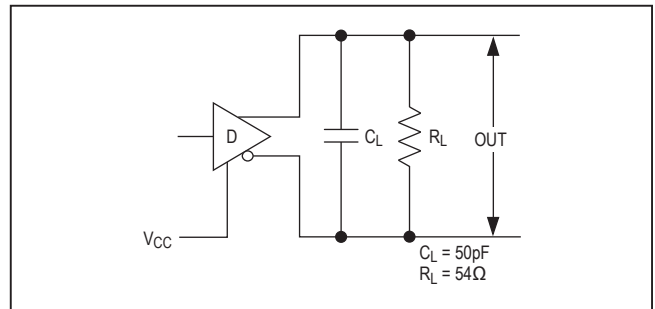

Figure 2. Driver Timing Test Circuit

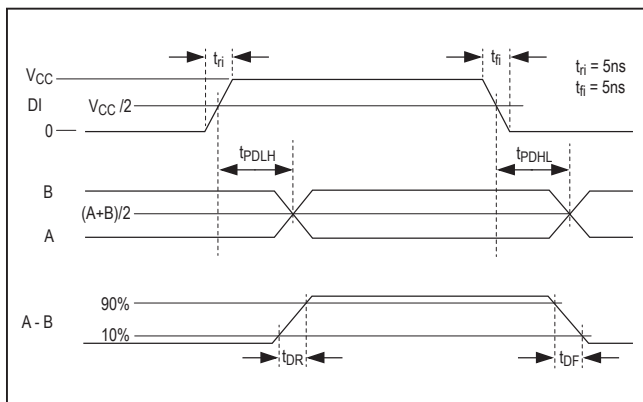

Figure 3. Driver Propagation Delay

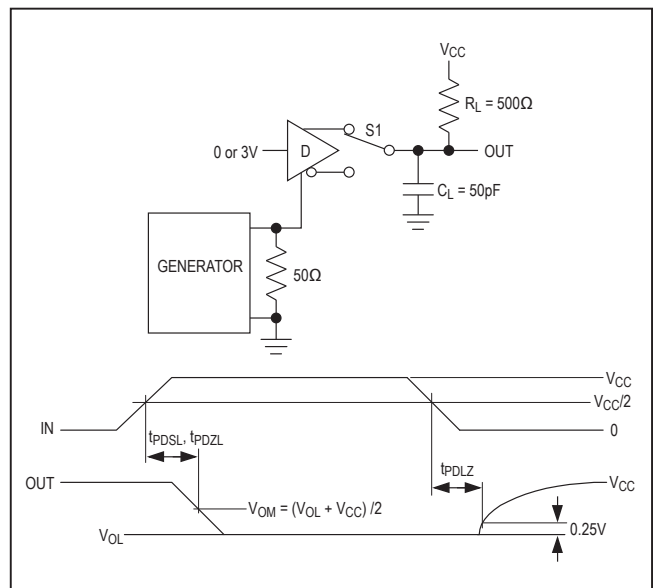

Figure 4. Driver Enable and Disable Times (tPDSL, tPDZL, tPDSL, tPDLZ)

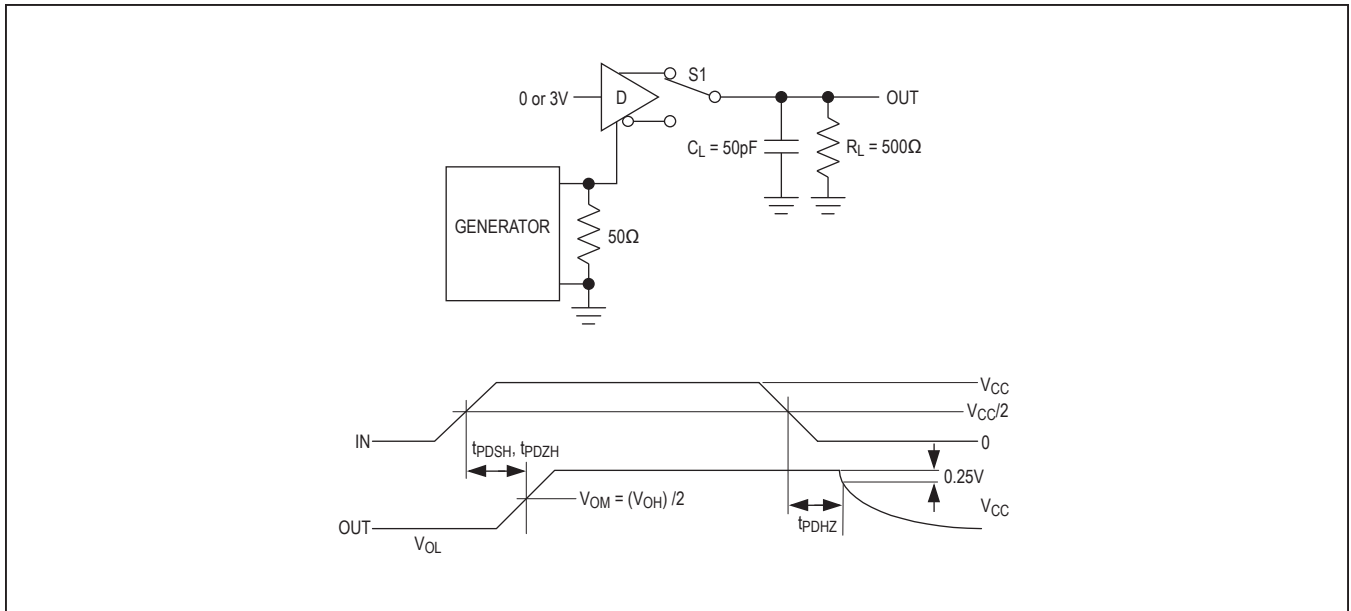

Figure 5. Driver Enable and Disable Times (t_{PDSH} , t_{PDZH} , t_{PDHS} , t_{PDHZ})

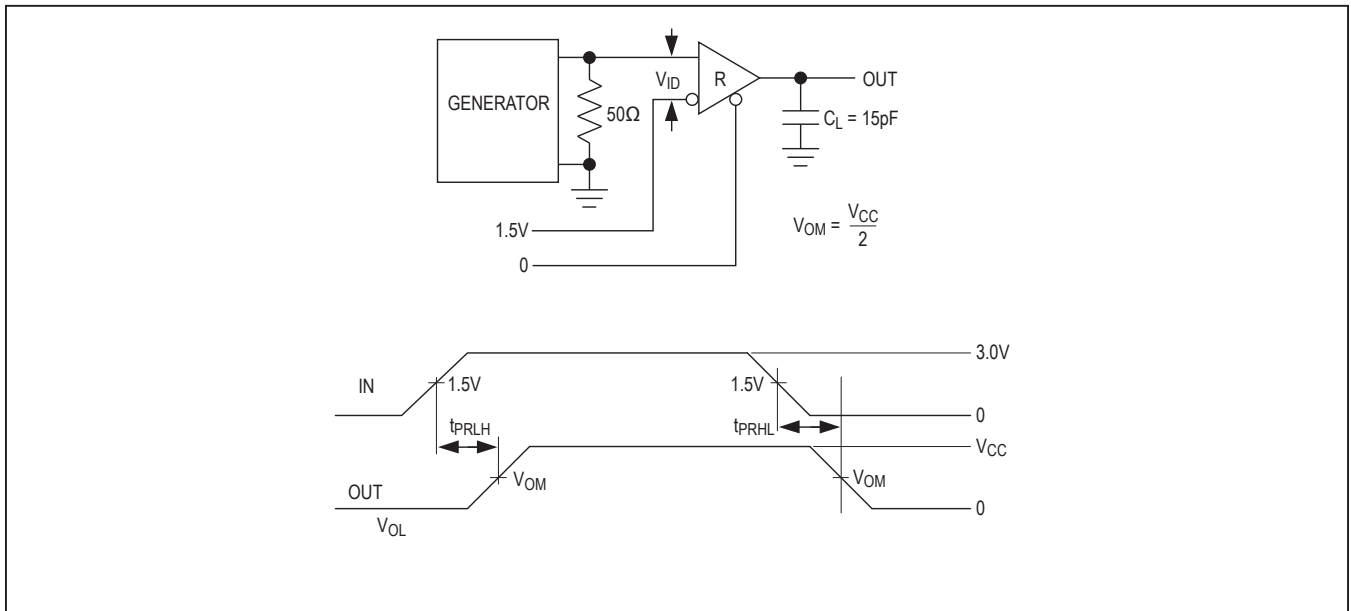

Figure 6. Receiver Propagation Delays

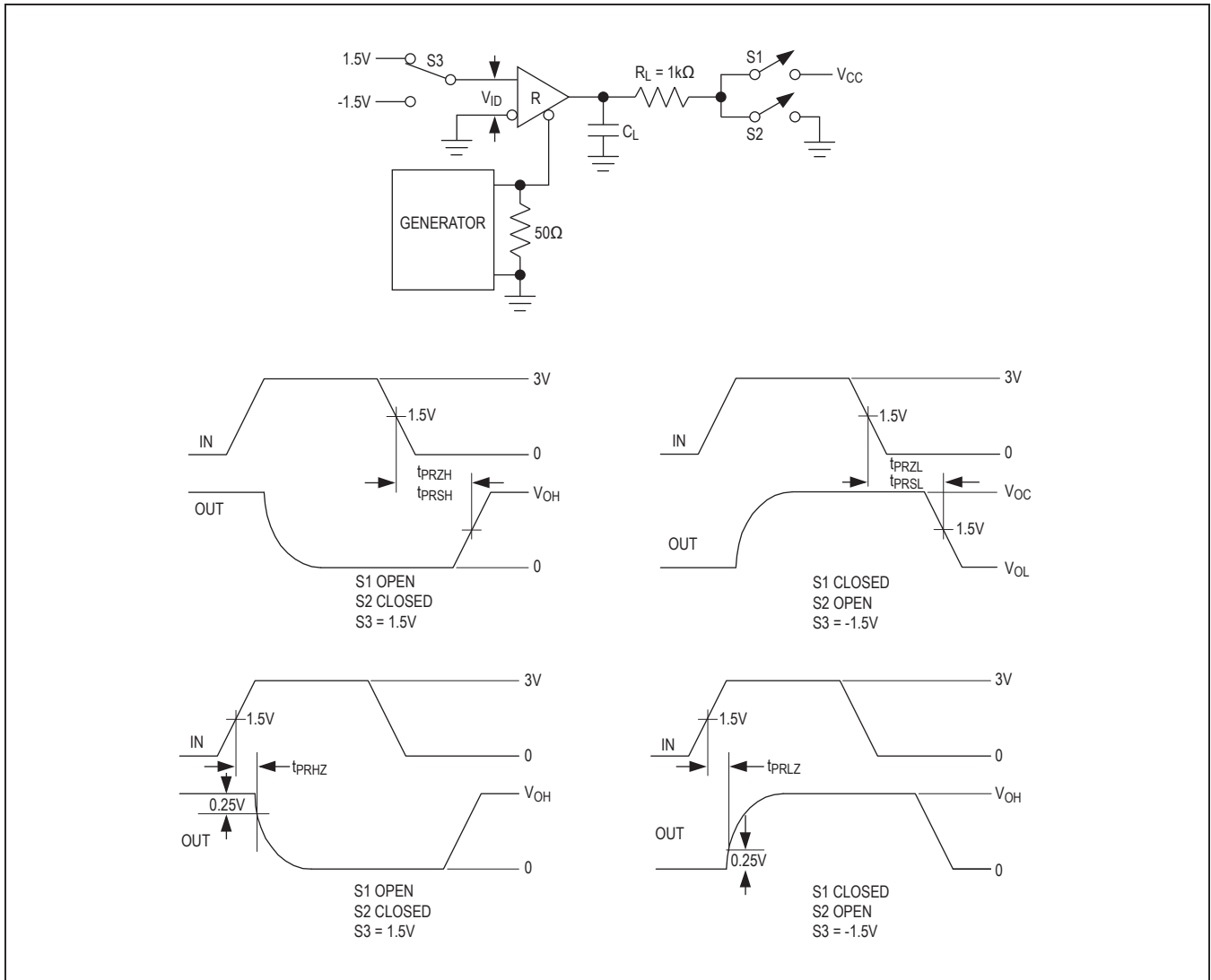

Figure 7. Receiver Enable and Disable Times

Detailed Description

The MAX3362 low-power, high-speed transceiver for RS-485/RS-422 communication operates from a single +3.3V power supply. The device contains one differential line driver and one differential line receiver. The driver and receiver may be independently enabled. When disabled, outputs enter a high-impedance state.

The transceiver guarantees data rates up to 20Mbps, with an output skew of less than 6ns. This low skew time makes the MAX3362 ideal for multidrop clock/data distribution applications, such as cellular base stations. Driver

and receiver propagation delays are below 50ns. The output level is guaranteed at 1.5V on a standard 54Ω load.

The device has a hot-swap feature that eliminates false transitions on the data cable during circuit initialization. Also, drivers are short-circuit current limited and are protected against excessive power dissipation by thermal shutdown circuitry.

The MAX3362 has a 1/8-unit-load receiver input impedance, allowing up to 256 transceivers to be connected simultaneously on a bus. The MAX3362 is designed for half-duplex communication.

Table 1. Typical Fault Conditions

TRANSMITTING				
INPUTS			OUTPUTS	
\overline{RE}	DE	DI	A	B
X	1	1	1	0
X	1	0	0	1
0	0	X	High Z	High Z
1	0	X	Shutdown	

Table 2. Receiver Functional Table

RECEIVING			
INPUTS			OUTPUT
\overline{RE}	DE	A – B	RO
0	X	$\geq 200\text{mV}$	1
0	X	$\leq -200\text{mV}$	0
1	1	X	High-Z
1	0	X	Shutdown

Driver

The driver transfers single-ended input (DI) to differential outputs (A, B). The driver enable (DE) input controls the driver. When DE is high, driver outputs are enabled. These outputs are high impedance when DE is low.

When the driver is enabled, setting DI low forces the noninverting output (A) low and inverting output (B) high. Conversely, drive DI high to force noninverting output high and inverting output low (Table 1).

Drive \overline{RE} high and DE low (disable both receiver and driver outputs) to enter low-power shutdown mode.

Receiver

The receiver reads differential inputs from the bus lines (A, B) and transfers this data as a single-ended output (RO). The receiver enable (\overline{RE}) input controls the receiver. Drive \overline{RE} low to enable the receiver. Driving \overline{RE} high places RO into a high-impedance state.

When the receiver is enabled, RO is high if (A-B) $\geq 200\text{mV}$. RO is low if (A-B) $\leq -200\text{mV}$.

Drive \overline{RE} high and DE low (disable both receiver and driver outputs) to enter low-power shutdown mode.

Hot-Swap Capability

Hot-Swap Input

When circuit boards are inserted into a hot or powered backplane, disturbances to the enable and differential receiver inputs can lead to data errors. Upon initial circuit board insertion, the processor undergoes its power-up sequence. During this period, the output drivers are high impedance and are unable to drive the DE input of the MAX3362 to a defined logic level. Leakage currents up to $10\mu\text{A}$ from the high-impedance output could cause DE to drift to an incorrect logic state. Additionally, parasitic circuit board capacitance could cause coupling of V_{CC} or GND to DE. These factors could improperly enable the driver.

When V_{CC} rises, an internal pulldown circuit holds DE low for at least $10\mu\text{s}$ and until the current into DE exceeds $200\mu\text{A}$. After the initial power-up sequence, the pulldown circuit becomes transparent, resetting the hot-swap tolerable input.

Hot-Swap Input Circuitry

The MAX3362 enable inputs feature hot-swap capability. At the input there are two NMOS devices, M1 and M2 (Figure 8). When V_{CC} ramps from 0, an internal $10\mu\text{s}$ timer turns on M2 and sets the SR latch, which also turns on M1. Transistors M2, a $300\mu\text{A}$ current sink, and M1, a $30\mu\text{A}$ current sink, pull DE to GND through an $8\text{k}\Omega$ resistor. M2 is designed to pull DE to the disabled state against an external parasitic capacitance up to 100pF that may drive DE high. After $10\mu\text{s}$, the timer deactivates M2 while M1 remains on, holding DE low against three-state leakages that may drive DE high. M1 remains on until an external source overcomes the required input current. At this time, the SR latch resets and M1 turns off. When M1 turns off, DE reverts to a standard, high-impedance CMOS input. Whenever V_{CC} drops below 1V, the hot-swap input is reset.

For \overline{RE} there is a complementary circuit employing two PMOS devices pulling \overline{RE} to V_{CC} .

Hot-Swap Line Transient

The circuit of Figure 9 shows a typical offset termination used to guarantee a greater than 200mV offset when a line is not driven (the 50pF represents the minimum parasitic capacitance that would exist in a typical application). During a hot-swap event when the driver is connected to the line and is powered up the driver must not cause the differential signal to drop below 200mV . Figures 10, 11,

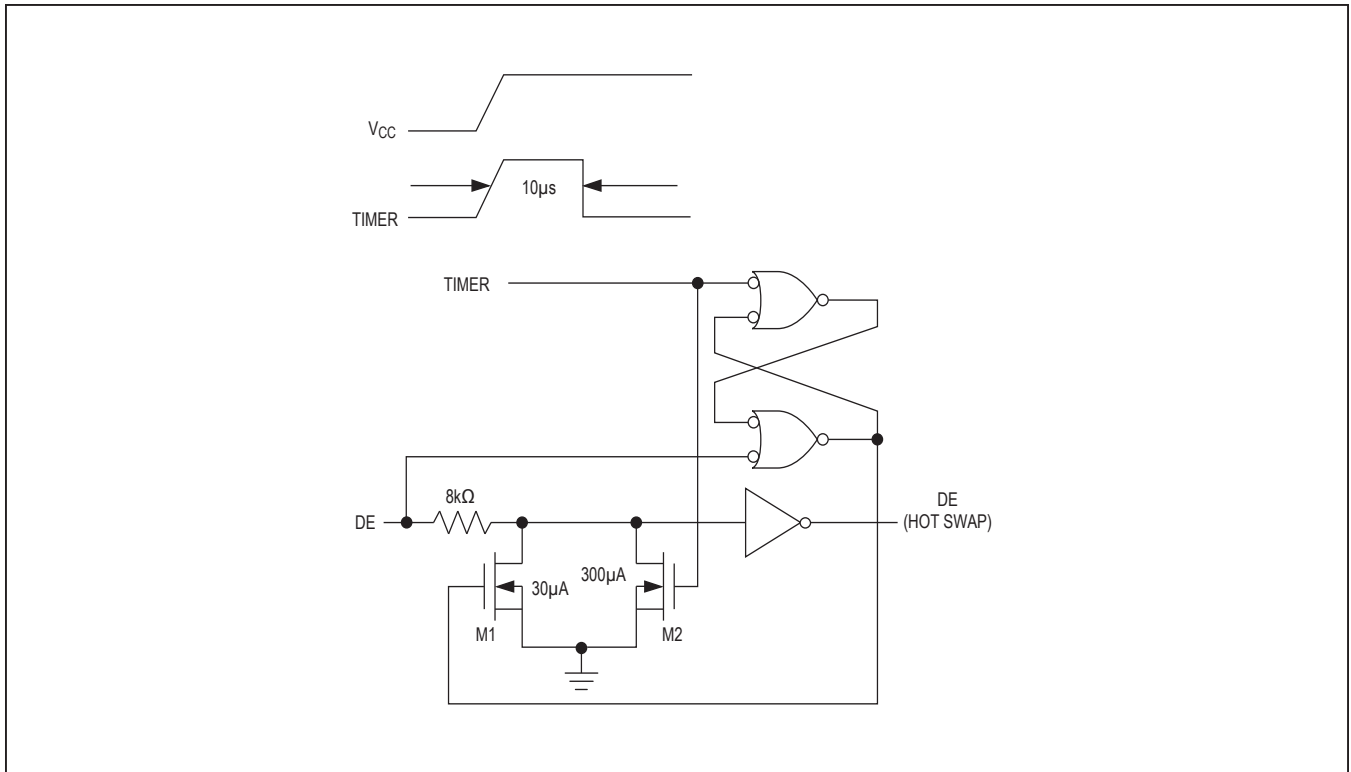

Figure 8. Simplified Structure of the Driver Enable Input (DE)

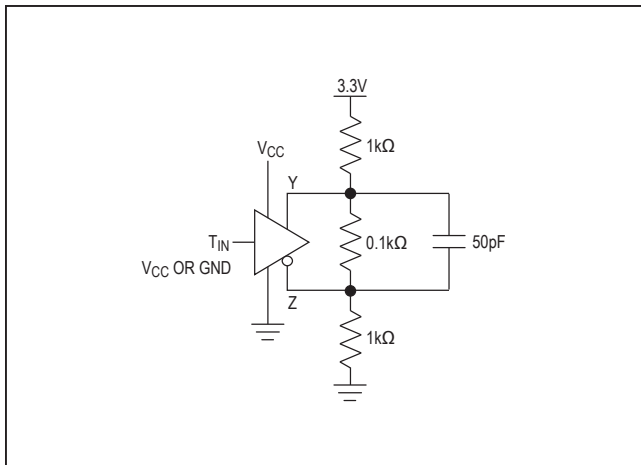

Figure 9. Differential Power-Up Glitch (Hot Swap)

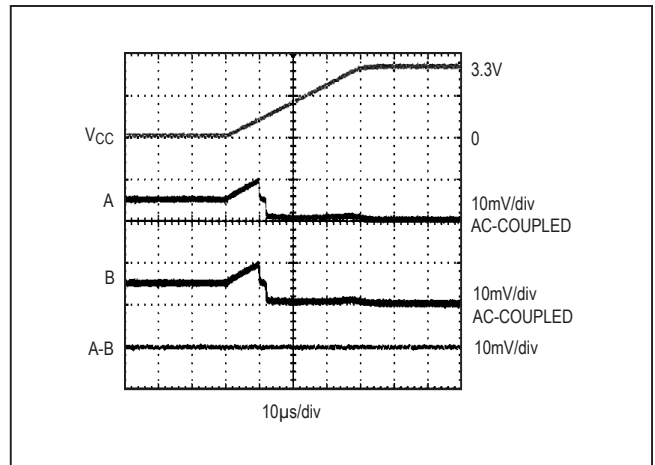

Figure 10. Differential Power-Up Glitch (0.1V/µs)

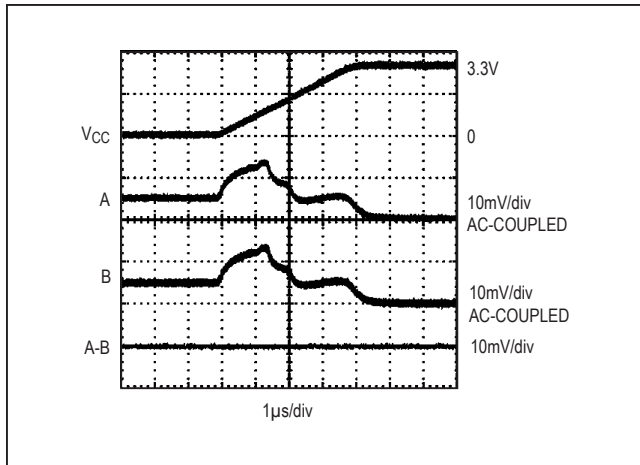

Figure 11. Differential Power-Up Glitch (1V/μs)

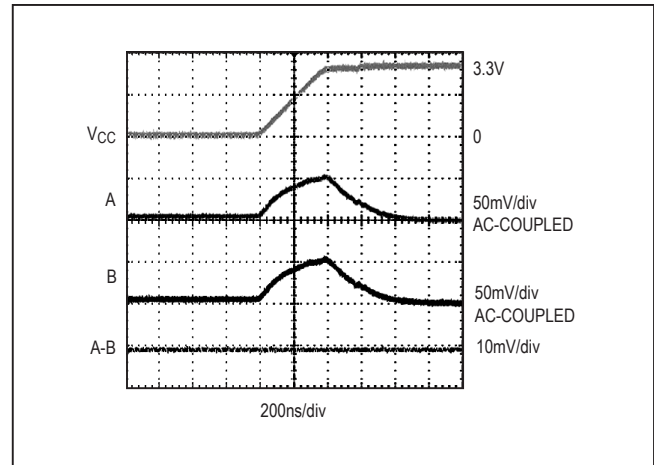

Figure 12. Differential Power-Up Glitch (10V/μs)

and 12 show the results of the MAX3362 during power-up for three different V_{CC} ramp rates (0.1V/μs, 1V/μs, and 10V/μs). The photos show the V_{CC} ramp, the single-ended signal on each side of the 100Ω termination, as well as the differential signal across the termination.

Low-Power Shutdown Mode

Low-power shutdown mode is initiated by bringing both \overline{RE} high and DE low. In shutdown, the MAX3362 typically draws only 1μA supply current.

\overline{RE} and DE may be driven simultaneously; the device is guaranteed not to enter shutdown if \overline{RE} is high and DE is low for less than 50ns. If the inputs are in this state for at least 600ns, the device will enter shutdown.

Enable times t_{PDZH} , t_{PDZL} , t_{PRZH} and t_{PRZL} in the *Switching Characteristics* table assume the device was not in a low-power shutdown state. Enable times t_{PDSH} , t_{PDSL} , t_{PRSH} , and t_{PRSL} assume the device was shut down. Drivers and receivers take longer to become enabled from low-power shutdown mode than from driver/receiver disable mode.

Applications Information

Propagation Delays

Figures 5 and 6 show the typical propagation delays. Skew time is simply the difference between the low-to-high and high-to-low propagation delay. Small driver/receiver skew times help maintain a symmetrical mark-space ratio (50% duty cycle). Both the receiver skew time and driver skew time are under 6ns.

256 Transceivers on the Bus

The standard RS-485 receiver input impedance is 12kΩ (one-unit load), and a standard driver can drive up to 32 unit loads. The MAX3362 transceiver has a 1/8-unit-load receiver input impedance (96kΩ), allowing up to 256 transceivers to be connected in parallel on one communication line. Any combination of these devices and/or other RS-485 transceivers with a total of 32 unit loads or less can be connected to the line.

Driver Output Protection

Two mechanisms prevent excessive output current and power dissipation caused by faults or by bus contention. The first, a foldback current limit on the output stage, provides immediate protection against short circuits over the whole common-mode voltage range (see *Typical Operating Characteristics*). The second, a thermal shutdown circuit, forces the driver outputs into a high-impedance state if the die temperature becomes excessive.

Typical Applications

The MAX3362 transceiver is designed for bidirectional data communications on multipoint bus transmission lines. The *Typical Operating Circuit* shows a typical network applications circuit. To minimize reflections, the line should be terminated at both ends in its characteristic impedance, and stub lengths off the main line should be kept as short as possible.

Pin Configuration

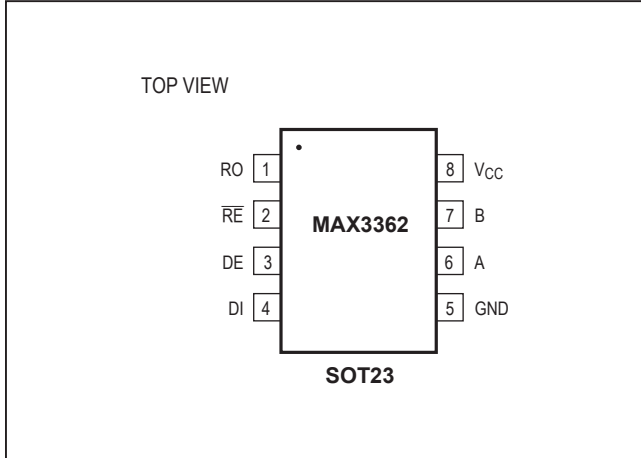

Functional Diagram

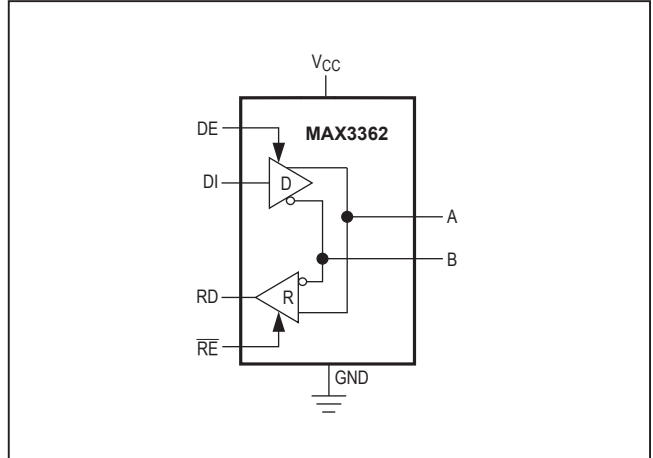

Chip Information

PROCESS: BiCMOS

Package Information

For the latest package outline information and land patterns (footprints), go to www.maximintegrated.com/packages. Note that a "+", "#", or "-" in the package code indicates RoHS status only. Package drawings may show a different suffix character, but the drawing pertains to the package regardless of RoHS status.

PACKAGE TYPE	PACKAGE CODE	OUTLINE NO.	LAND PATTERN
8 SOT23	K8F+4	21-0078	90-0176