



1.6 μ A, RS-485/RS-422, Half-Duplex, Differential Transceiver for Battery-Powered Systems

MAX3471

General Description

The MAX3471 half-duplex transceiver is intended for lithium battery-powered RS-485/RS-422 applications. It draws only 1.6 μ A (typical) supply current from a 3.6V supply with the receiver enabled and the driver disabled. Its wide 2.5V to 5.5V supply voltage guarantees operation over the lifetime of a lithium battery.

This device features true fail-safe operation that guarantees a logic-high receiver output when the receiver inputs are open or shorted. This means that the receiver output will be a logic high if all transmitters on a terminated bus are disabled (high impedance). The MAX3471 has a 1/8-unit load input resistance. When driver outputs are enabled and pulled above V_{CC} or below GND, internal circuitry prevents battery back-charging.

The MAX3471 is available in an 8-pin μ MAX package.

Applications

- Remote Meter Reading
- Battery-Powered Differential Communications
- Level Translators

Features

- ◆ 1.6 μ A Supply Current with Receiver Enabled
- ◆ +2.5V to +5.5V Single-Supply Operation
- ◆ True Fail-Safe Receiver Input
- ◆ Available in μ MAX Package
- ◆ 1/8-Unit-Load Receiver Input
- ◆ -7V to +10V Common-Mode Input Voltage Range

Ordering Information

PART	TEMP. RANGE	PIN-PACKAGE
MAX3471CUA	0°C to +70°C	8 μ MAX
MAX3471EUA	-40°C to +85°C	8 μ MAX

Pin Configuration

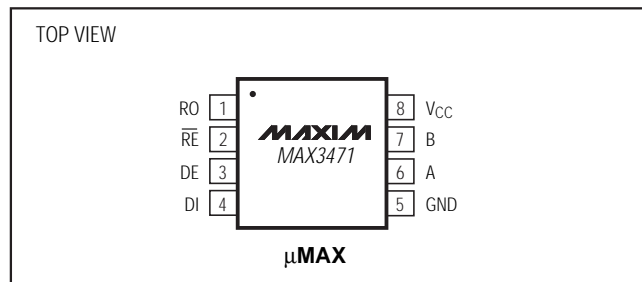

Typical Application Circuit

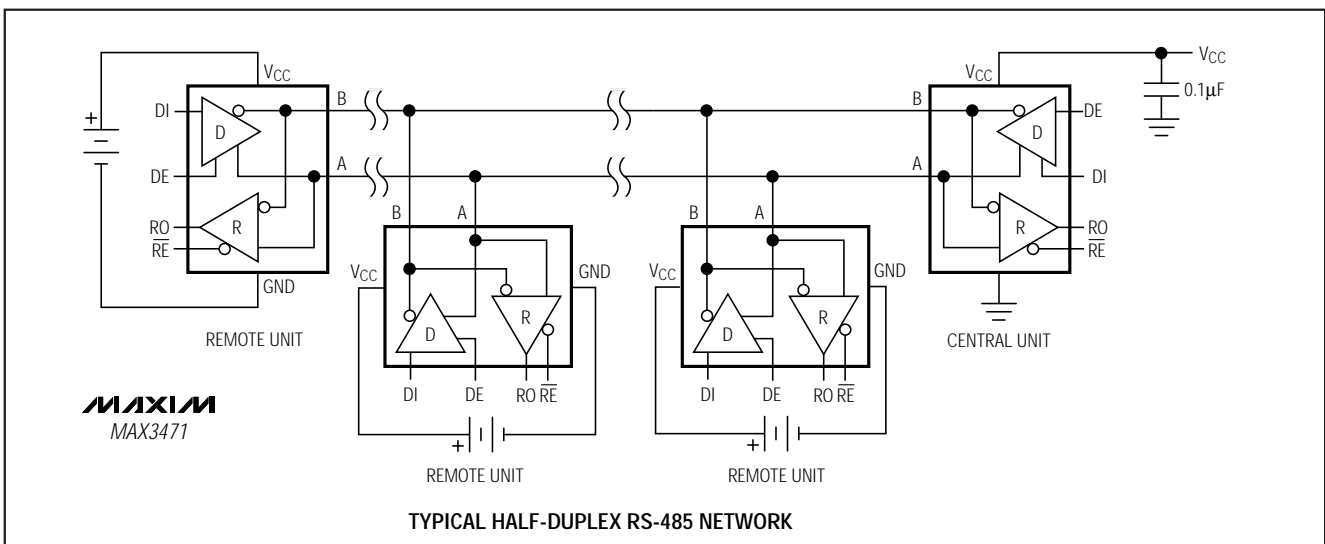

1.6 μ A, RS-485/RS-422, Half-Duplex, Differential Transceiver for Battery-Powered Systems

ABSOLUTE MAXIMUM RATINGS (Note 1)

Supply Voltage (V_{CC})7V
Control Input Voltage (\overline{RE} , DE)-0.3V to ($V_{CC} + 0.3V$)
Driver Input Voltage (DI)-0.3V to ($V_{CC} + 0.3V$)
Driver Output/Receiver Input Voltage (A, B) $\pm 10.5V$
Receiver Output Voltage (RO)-0.3V to ($V_{CC} + 0.3V$)
Continuous Power Dissipation	
μ MAX (derate 4.5mW/ $^{\circ}C$ above +70 $^{\circ}C$)362mW

Operating Temperature Ranges

MAX3471CUA0 $^{\circ}C$ to +70 $^{\circ}C$
MAX3471EUA-40 $^{\circ}C$ to +85 $^{\circ}C$
Storage Temperature Range-65 $^{\circ}C$ to +160 $^{\circ}C$
Lead Temperature (soldering, 10sec)+300 $^{\circ}C$

Note 1: All currents into the device are positive; all currents out of the device are negative. All voltages are referred to device ground unless otherwise noted.

Stresses beyond those listed under "Absolute Maximum Ratings" may cause permanent damage to the device. These are stress ratings only, and functional operation of the device at these or any other conditions beyond those indicated in the operational sections of the specifications is not implied. Exposure to absolute maximum rating conditions for extended periods may affect device reliability.

DC ELECTRICAL CHARACTERISTICS

($V_{CC} = +2.5V$ to +5.5V, $T_A = T_{MIN}$ to T_{MAX} , unless otherwise noted. Typical values are at $V_{CC} = +3.6V$ and $T_A = +25^{\circ}C$.) (Note 1)

PARAMETER	SYMBOL	CONDITIONS	MIN	TYP	MAX	UNITS
Differential Driver Output (no load)	V_{OD1}	Figure 1 (R = open)			V_{CC}	V
Differential Driver Output (with load)	V_{OD2}	Figure 1	R = 750 Ω (RS-422)	1.5	3.28	V
			R = 27 Ω (RS-485)	0.2	0.83	
			R = 27 Ω (RS-485), $V_{CC} = 5V$, $T_A = +25^{\circ}C$		1.5	
Change in Magnitude of Differential Output Voltage (Note 2)	ΔV_{OD}	Figure 1, R = 750 Ω or 27 Ω			0.2	V
Driver Common-Mode Output Voltage	V_{OC}	Figure 1, R = 750 Ω or 27 Ω			0.6 x V_{CC}	V
Change in Magnitude of Common-Mode Voltage (Note 2)	ΔV_{OC}	Figure 1, R = 750 Ω or 27 Ω			0.2	V
Input High Voltage	V_{IH}	DE, DI, \overline{RE}	0.7 x V_{CC}			V
Input Low Voltage	V_{IL}	DE, DI, \overline{RE}			0.3 x V_{CC}	V
DI Input Hysteresis	V_{HYS}		100			mV
Input Current	I_{IN1}	DE, DI, \overline{RE}	± 0.001		± 1	μA
Input Current (A and B), Half Duplex	I_{IN2}	DE = GND, $V_{CC} = GND$ or 5.5V	$V_{IN} = 10V$	0.105		mA
			$V_{IN} = -7V$	-0.075		
Driver Short-Circuit Output Current (Note 3)	I_{OSD}	-7V $\leq V_{OUT} \leq 10V$	$V_{CC} \leq 3.6V$	-60	60	mA
			$V_{CC} \leq 5.5V$	-130	130	
Receiver Differential Threshold Voltage	V_{TH}	-7V $\leq V_{CM} \leq 10V$	-450	-250	-50	mV
Receiver Input Hysteresis	ΔV_{TH}	$V_{CM} = 0$	32			mV
Receiver Output High Voltage	V_{OH}	$I_O = -0.8mA$, $V_{ID} = -50mV$	$V_{CC} - 0.4$			V
Receiver Output Low Voltage	V_{OL}	$I_O = 2.2mA$, $V_{ID} = -450mV$			0.4	V
Three-State Current at Receiver Output	I_{OZR}	$0 \leq V_O \leq V_{CC}$			± 1	μA
Receiver Input Resistance	R_{IN}	-7V $\leq V_{CM} \leq 10V$	96			k Ω

1.6µA, RS-485/RS-422, Half-Duplex, Differential Transceiver for Battery-Powered Systems

MAX3471

DC ELECTRICAL CHARACTERISTICS (continued)

(V_{CC} = +2.5V to +5.5V, T_A = T_{MIN} to T_{MAX}, unless otherwise noted. Typical values are at V_{CC} = +3.6V and T_A = +25°C.) (Note 1)

PARAMETER	SYMBOL	CONDITIONS		MIN	TYP	MAX	UNITS
Receiver Output Short-Circuit Current	I _{OSR}	0 ≤ V _{RO} ≤ V _{CC}	V _{CC} ≤ 3.6V	-20		50	mA
			V _{CC} ≤ 5.5V	-40		110	
Supply Current	I _{CC}	V _{CC} ≤ 3.6V, no load, RE = DI = GND or V _{CC} , V _A = V _B = 0	DE = V _{CC}		50	60	µA
			DE = GND		1.6	2	
		V _{CC} ≤ 5.5V, no load, RE = DI = GND or V _{CC} , V _A = V _B = 0	DE = V _{CC}		83	100	
			DE = GND		2.8	4	

SWITCHING CHARACTERISTICS

(V_{CC} = +2.5V to +5.5V, T_A = T_{MIN} to T_{MAX}, unless otherwise noted. Typical values are at V_{CC} = +3.6V and T_A = +25°C.)

PARAMETER	SYMBOL	CONDITIONS	MIN	TYP	MAX	UNITS
Driver Input to Output Propagation Delay	t _{DPLH} , t _{DPHL}	Figures 3 and 5, R _{DIFF} = 1.5kΩ, C _{L1} = C _{L2} = 100pF		1.40	2.00	µs
Driver Output Skew (t _{DPLH} - t _{DPHL})	t _{DSKEW}	Figures 3 and 5, R _{DIFF} = 1.5kΩ, C _{L1} = C _{L2} = 100pF		0.025		µs
Driver Rise or Fall Time	t _{DR} , t _{DF}	Figures 3 and 5, R _{DIFF} = 1.5kΩ, C _{L1} = C _{L2} = 100pF	0.75	1.34	1.75	µs
Driver Enable Time to Output High	t _{DZH}	Figures 4 and 6, C _L = 100pF, S2 closed, S1 open		1.5	6.00	µs
Driver Enable Time to Output Low	t _{DZL}	Figures 4 and 6, C _L = 100pF, S1 closed, S2 open		0.86	4.00	µs
Driver Disable Time from Low	t _{DLZ}	Figures 4 and 6, C _L = 15pF, S1 closed, S2 open		0.4	1.5	µs
Driver Disable Time from High	t _{DHZ}	Figures 4 and 6, C _L = 15pF, S2 closed, S1 open		0.6	1.5	µs
Receiver Input to Output Propagation Delay	t _{RPLH}	Figures 7 and 9, C _L = 15pF, V _{ID} = 2V		5.2	12	µs
	t _{RPHL}			6.4	12	
Differential Receiver Skew (t _{RPLH} - t _{RPHL})	t _{RSKEW}	Figures 7 and 9, V _{ID} = 2V		1.2		µs
Data Rate	f _{MAX}	Figure 9, C _L = 100pF	64			kbps
Receiver Enable Time to Output Low	t _{RZL}	Figures 2 and 8, C _L = 15pF, S1 closed, S2 open		70	500	ns
Receiver Enable Time to Output High	t _{RZH}	Figures 2 and 8, C _L = 15pF, S2 closed, S1 open		85	500	ns
Receiver Disable Time from Low	t _{RLZ}	Figures 2 and 8, C _L = 15pF, S1 closed, S2 open		50	200	ns
Receiver Disable Time from High	t _{RHZ}	Figures 2 and 8, C _L = 15pF, S2 closed, S1 open		35	200	ns

Note 1: All currents into the device are positive; all currents out of the device are negative. All voltages are referred to device ground unless otherwise noted.

Note 2: ΔV_{OD} and ΔV_{OC} are the changes in magnitude of V_{OD} and V_{OC}, respectively, when the DI input changes state.

Note 3: Maximum and minimum current levels apply to peak current just prior to foldback-current limiting.

1.6µA, RS-485/RS-422, Half-Duplex, Differential Transceiver for Battery-Powered Systems

Typical Operating Characteristics

(V_{CC} = +3.6V, T_A = +25°C, unless otherwise noted.)

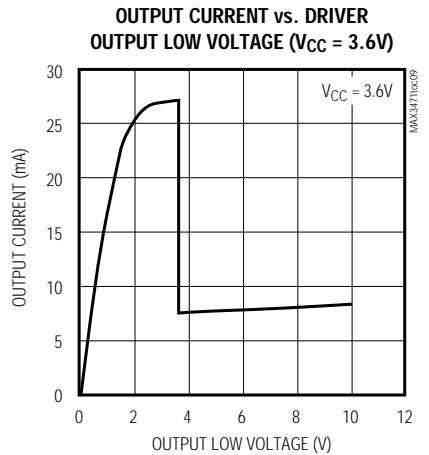
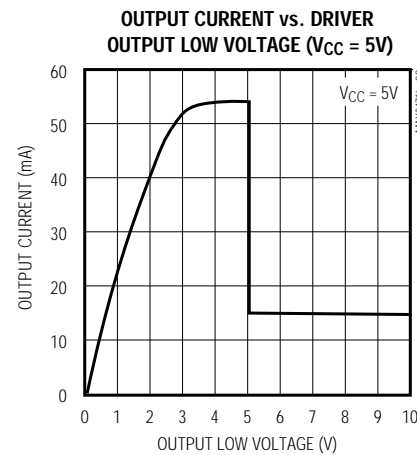
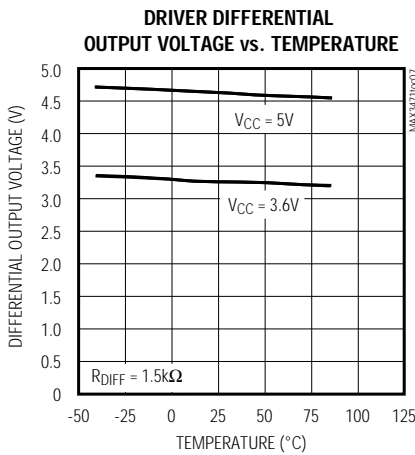
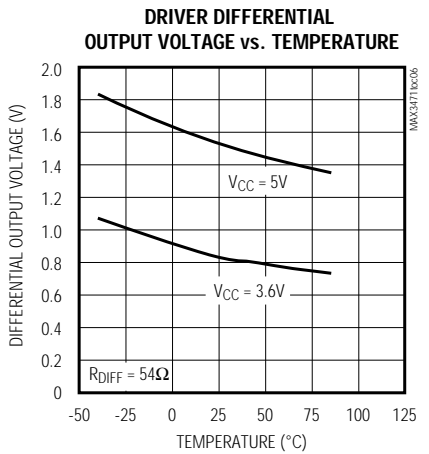
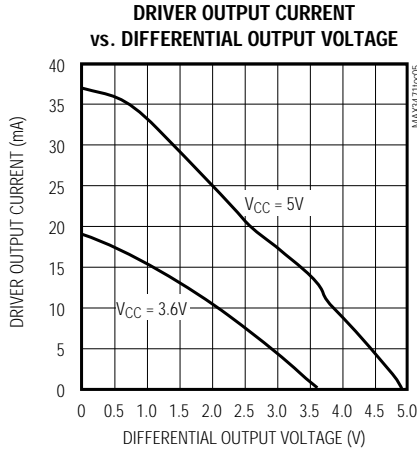
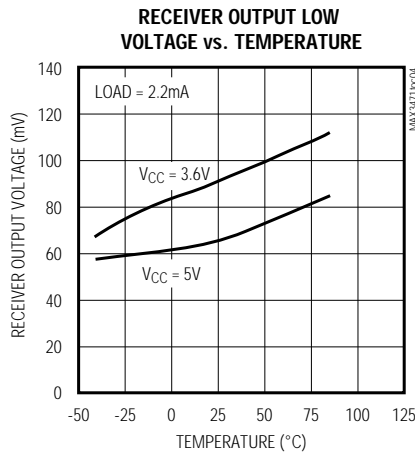
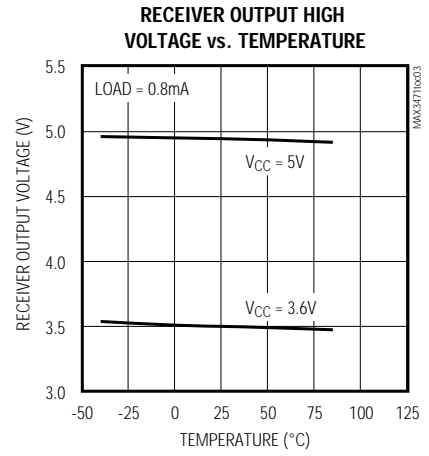
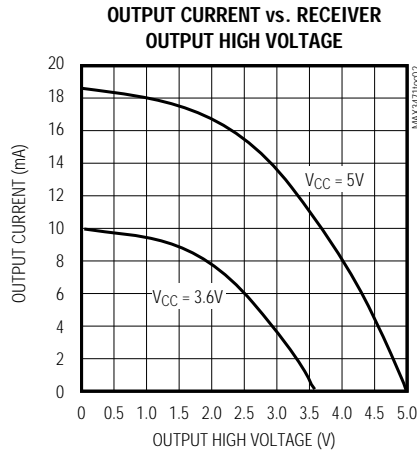
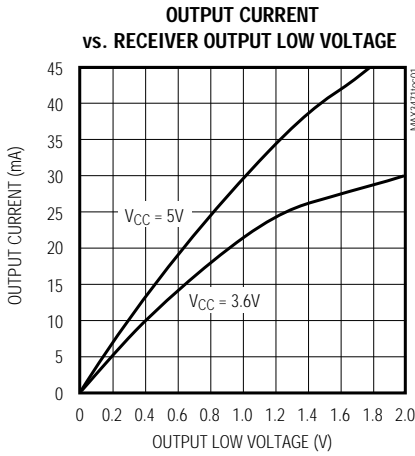

1.6µA, RS-485/RS-422, Half-Duplex, Differential Transceiver for Battery-Powered Systems

MAX3471

Typical Operating Characteristics (continued)

($V_{CC} = +3.6V$, $T_A = +25^\circ C$, unless otherwise noted.)

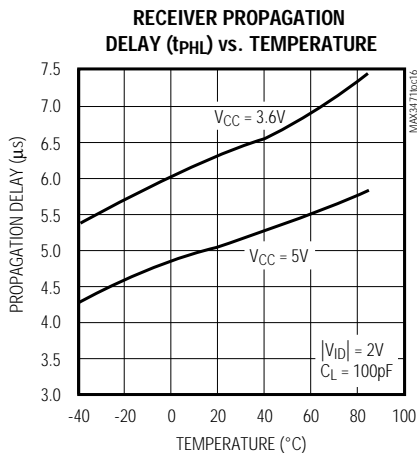
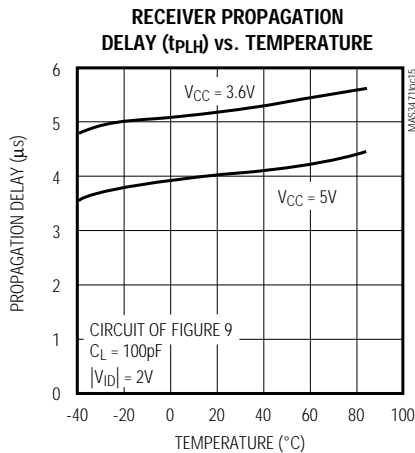
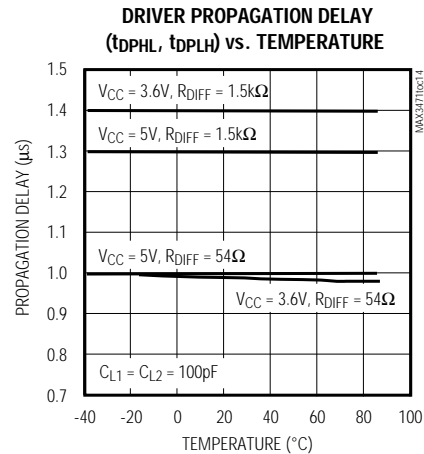
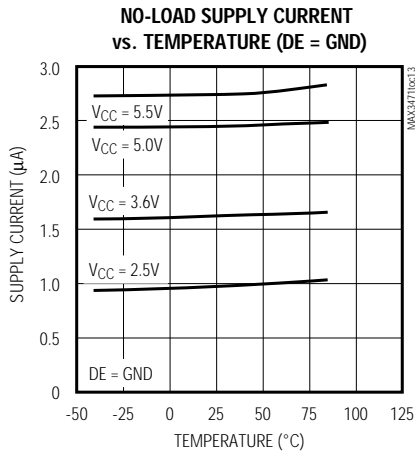
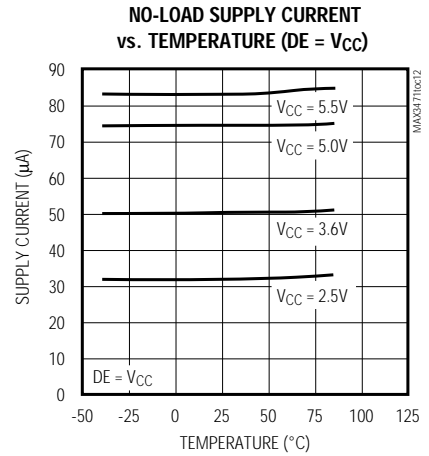
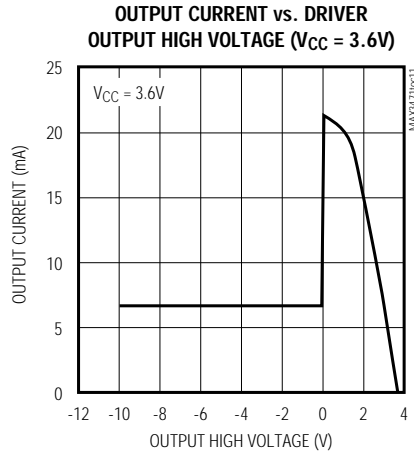
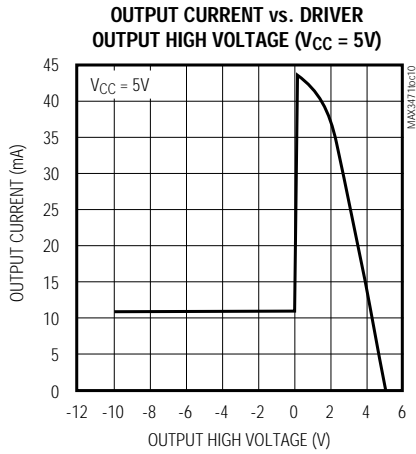

1.6 μ A, RS-485/RS-422, Half-Duplex, Differential Transceiver for Battery-Powered Systems

Typical Operating Characteristics (continued)

($V_{CC} = +3.6V$, $T_A = +25^\circ C$, unless otherwise noted.)

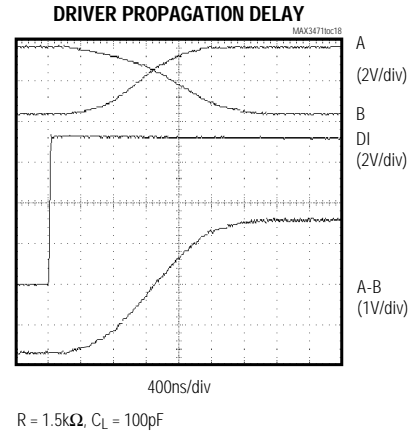
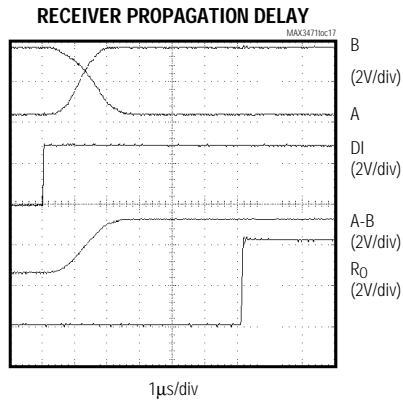

Pin Description

PIN	NAME	FUNCTION
1	RO	Receiver Output. When \overline{RE} is low, if $A - B \geq -50mV$, RO will be high; if $A - B \leq -450mV$, RO will be low.
2	\overline{RE}	Receiver Output Enable. Drive \overline{RE} low to enable RO; RO is high impedance when \overline{RE} is high.
3	DE	Driver Output Enable. Drive DE high to enable the driver outputs. These outputs are high impedance when DE is low.
4	DI	Driver Input. With DE high, a low on DI forces the noninverting output low and the inverting output high. Similarly, a high on DI forces the noninverting output high and the inverting output low.
5	GND	Ground
6	A	Noninverting Driver Output and Noninverting Receiver Input
7	B	Inverting Driver Output and Inverting Receiver Input
8	VCC	Positive Supply: $+2.5V \leq V_{CC} \leq +5.5V$

Detailed Description

The MAX3471 half-duplex transceiver consumes only 1.6 μ A from a single +3.6V supply. Its wide 2.5V to 5.5V supply voltage guarantees operation over the lifetime of a lithium battery. This device contains one driver and one receiver. Its true fail-safe receiver input guarantees a logic-high receiver output when the receiver inputs are open or shorted, or when they are connected to a terminated transmission line with all drivers disabled. Reduced-slew-rate drivers minimize EMI and reduce reflections caused by improperly terminated cables, allowing error-free data transmission up to 64kbps.

Receiver Input Filtering

The MAX3471 receiver operates at up to 64kbps and incorporates input filtering in addition to input hystere-

sis. This filtering enhances noise immunity when differential signals have very slow rise and fall times.

The MAX3471 guarantees a logic-high receiver output when the receiver inputs are shorted or open, or when they are connected to a terminated transmission line with all drivers disabled. This is accomplished by setting the receiver threshold between -50mV and -450mV. If the differential receiver input voltage (A-B) is greater than or equal to -50mV, RO is a logic high. If A-B is less than or equal to -450mV, RO is a logic low. In the case of a terminated bus with all transmitters disabled, the receiver's differential input voltage is pulled to 0V by the termination. With the MAX3471's receiver thresholds, this results in a logic high with a 50mV minimum noise margin.

1.6μA, RS-485/RS-422, Half-Duplex, Differential Transceiver for Battery-Powered Systems

Table 1. Transmitting

INPUTS			OUTPUTS	
\overline{RE}	DE	DI	B	A
X	1	1	0	1
X	1	0	1	0
0	0	X	Z _D	Z _D
1	0	X	Z _D	Z _D

Z_D = Driver output disabled

Table 2. Receiving

INPUTS			OUTPUT
\overline{RE}	DE	A-B	RO
0	0	$\geq -0.05V$	1
0	0	$\leq -0.45V$	0
0	0	Open/Shorted	1
1	0	X	Z

X = Don't care

Z = Receiver output high impedance

Applications Information

Transceivers on the Bus

The MAX3471 is optimized for the unterminated bus normally used in slow, low-power systems. With a +2.5V supply, the part is guaranteed to drive up to eight standard loads (for example, 64 other MAX3471s or 56 MAX3471s plus one standard load). Drive capability increases significantly with supply. For example, with a +5V supply, the MAX3471 typically meets the RS-485 driver output specifications (1.5V with 54Ω differential termination). See the *Typical Operating Characteristics*.

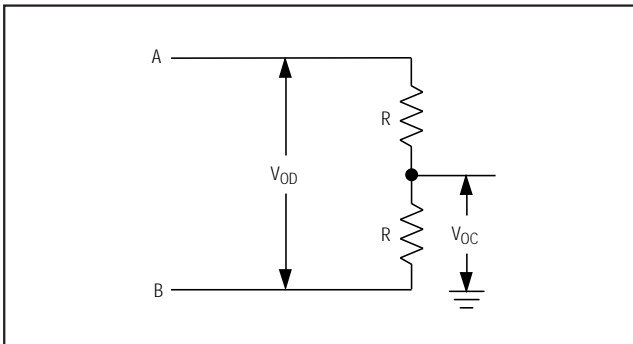

Figure 1. Driver DC Test Load

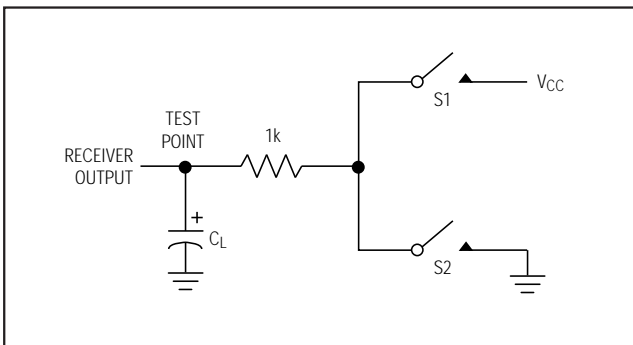

Figure 2. Receiver Enable/Disable Timing Test Load

Reduced EMI and Reflections

The MAX3471 is slew-rate limited, minimizing EMI and reducing reflections caused by improperly terminated cables. In general, the rise time of a transmitter directly relates to the length of an unterminated stub, which can be driven with only minor waveform reflections. The following equation expresses this relationship conservatively:

$$\text{Length} = t_{\text{RISE}} / (10 \times 1.5\text{ns/foot})$$

where t_{RISE} is the transmitter's rise time.

For example, the MAX3471's rise time is typically 1.3μs, which results in excellent waveforms with a stub length up to 82 feet. In general, systems operate well with longer unterminated stubs, even with severe reflections, if the waveform settles out before the UART samples them.

Driver Output Protection

Excessive output current and power dissipation caused by faults or bus contention are prevented by foldback current limiting. A foldback current limit on the output stage provides immediate protection against short circuits over the whole common-mode voltage range (see *Typical Operating Characteristics*).

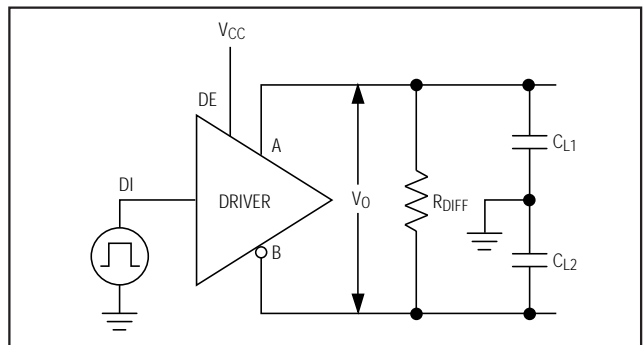

Figure 3. Driver Test Circuit