

EVALUATION KIT
AVAILABLE

155Mbps to 622Mbps SFF/SFP Laser Driver with Extinction Ratio Control

MAX3646

General Description

The MAX3646 is a +3.3V laser driver designed for multirate transceiver modules with data rates from 155Mbps to 622Mbps. Lasers can be DC-coupled to the MAX3646 for reduced component count and ease of multirate operation.

Laser extinction ratio control (ERC) combines the features of automatic power control (APC), modulation compensation, and built-in thermal compensation. The APC loop maintains constant average optical power. Modulation compensation increases the modulation current in proportion to the bias current. These control loops, combined with thermal compensation, maintain a constant optical extinction ratio over temperature and lifetime.

The MAX3646 accepts differential data input signals. The wide 5mA to 60mA (up to 85mA AC-coupled) modulation current range and up to 100mA bias current range, make the MAX3646 ideal for driving FP/DFB lasers in fiber optic modules. External resistors set the required laser current levels. The MAX3646 provides transmit disable control (TX_DISABLE), single-point fault tolerance, bias-current monitoring, and photocurrent monitoring. The device also offers a latched failure output (TX_FAULT) to indicate faults, such as when the APC loop is no longer able to maintain the average optical power at the required level. The MAX3646 is compliant with the SFF-8472 transmitter diagnostic and SFP MSA timing requirements.

The MAX3646 is offered in a 4mm x 4mm, 24-pin thin QFN package and operates over the extended -40°C to +85°C temperature range.

Applications

Multirate OC-3 to OC-12 FEC Transceivers
125Mbps Ethernet SFP, GBIC, and 1 x 9
Transceivers

Typical Application Circuit appears at end of data sheet.

Features

- ◆ Single +3.3V Power Supply
- ◆ 47mA Power-Supply Current
- ◆ 85mA Modulation Current
- ◆ 100mA Bias Current
- ◆ Automatic Power Control (APC)
- ◆ Modulation Compensation
- ◆ On-Chip Temperature Compensation
- ◆ Self-Biased Inputs for AC-Coupling
- ◆ Ground-Referenced Current Monitors
- ◆ Laser Shutdown and Alarm Outputs
- ◆ Enable Control and Laser Safety Feature

Ordering Information

PART	TEMP RANGE	PIN-PACKAGE
MAX3646ETG	-40°C to +85°C	24 Thin QFN-EP*
MAX3646ETG-T	-40°C to +85°C	24 Thin QFN-EP*
MAX3646ETG+	-40°C to +85°C	24 Thin QFN-EP*
MAX3646ETG+T	-40°C to +85°C	24 Thin QFN-EP*

+ Denotes a lead-free/RoHS-compliant package.

*EP = Exposed pad.

T = Tape and reel.

Pin Configuration

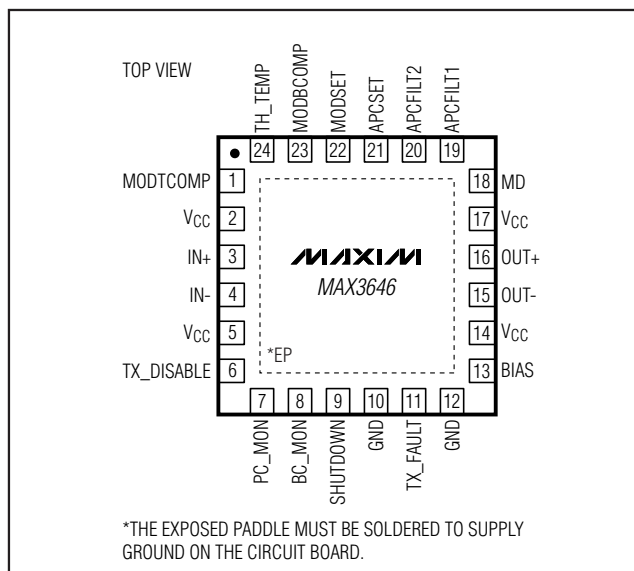

155Mbps to 622Mbps SFF/SFP Laser Driver with Extinction Ratio Control

ABSOLUTE MAXIMUM RATINGS

Supply Voltage V_{CC}-0.5V to +6.0V
 IN+, IN-, TX_DISABLE, TX_FAULT, SHUTDOWN,
 BC_MON, PC_MON, APCFILT1, APCFILT2,
 MD, TH_TEMP, MODTCOMP, MODBCOMP,
 MODSET, and APCSET Voltage.....-0.5V to ($V_{CC} + 0.5V$)
 OUT+, OUT-, BIAS Current.....-20mA to +150mA
 Continuous Power Dissipation ($T_A = +70^\circ\text{C}$)
 24-Pin TQFN (derate 27.8mW/ $^\circ\text{C}$ above +70 $^\circ\text{C}$)2222mW

Operating Junction Temperature Range.....-55 $^\circ\text{C}$ to +150 $^\circ\text{C}$
 Lead Temperature (soldering, 10s)+300 $^\circ\text{C}$
 Soldering Temperature (reflow)
 Lead (Pb)-free packages.....+260 $^\circ\text{C}$
 Packages containing lead (Pb).....+240 $^\circ\text{C}$
 Storage Temperature Range.....-55 $^\circ\text{C}$ to +150 $^\circ\text{C}$

Stresses beyond those listed under "Absolute Maximum Ratings" may cause permanent damage to the device. These are stress ratings only, and functional operation of the device at these or any other conditions beyond those indicated in the operational sections of the specifications is not implied. Exposure to absolute maximum rating conditions for extended periods may affect device reliability.

ELECTRICAL CHARACTERISTICS

($V_{CC} = +2.97\text{V}$ to +3.63V, $T_A = -40^\circ\text{C}$ to +85 $^\circ\text{C}$. Typical values are at $V_{CC} = +3.3\text{V}$, $I_{BIAS} = 60\text{mA}$, $I_{MOD} = 60\text{mA}$, $T_A = +25^\circ\text{C}$, unless otherwise noted.) (Notes 1, 2)

PARAMETER	SYMBOL	CONDITIONS		MIN	TYP	MAX	UNITS
POWER SUPPLY							
Supply Current	I_{CC}	(Note 3)			47	60	mA
Power-Supply Noise Rejection	PSNR	$f \leq 1\text{MHz}$, 100mA _{P-P} (Note 4)			33		dB
I/O SPECIFICATIONS							
Differential Input Swing	V_{ID}	DC-coupled, Figure 1		0.2		2.4	V_{P-P}
Common-Mode Input	V_{CM}			1.7		$V_{CC} - V_{ID} / 4$	V
LASER BIAS							
Bias-Current-Setting Range				1		100	mA
Bias Off Current		TX_DISABLE = high				0.1	mA
Bias-Current Monitor Ratio		I_{BIAS} / I_{BC_MON}		62	76	90	mA/mA
LASER MODULATION							
Modulation Current-Setting Range	I_{MOD}	(Note 5)		5		85	mA
Output Edge Speed		20% to 80% (Notes 6, 7)	$5\text{mA} \leq I_{MOD} \leq 85\text{mA}$		100	200	ps
Output Overshoot/Undershoot		(Note 7)			± 6		%
Random Jitter		(Notes 6, 7)			1.1	2.5	psRMS
Deterministic Jitter (Notes 6, 8)		622Mbps, $5\text{mA} \leq I_{MOD} \leq 85\text{mA}$			24	46	pSP-P
		155Mbps, $5\text{mA} \leq I_{MOD} \leq 85\text{mA}$			45	100	
Modulation-Current Temperature Stability		(Note 6)	$5\text{mA} \leq I_{MOD} \leq 10\text{mA}$		± 175	± 600	ppm/ $^\circ\text{C}$
			$10\text{mA} < I_{MOD} \leq 85\text{mA}$		± 125	± 480	
Modulation-Current-Setting Error		15 Ω load, $T_A = +25^\circ\text{C}$	$5\text{mA} \leq I_{MOD} \leq 10\text{mA}$			± 20	%
			$10\text{mA} < I_{MOD} \leq 85\text{mA}$			± 15	
Modulation Off Current		TX_DISABLE = high				0.1	mA

155Mbps to 622Mbps SFF/SFP Laser Driver with Extinction Ratio Control

MAX3646

ELECTRICAL CHARACTERISTICS (continued)

(V_{CC} = +2.97V to +3.63V, T_A = -40°C to +85°C. Typical values are at V_{CC} = +3.3V, I_{BIAS} = 60mA, I_{MOD} = 60mA, T_A = +25°C, unless otherwise noted.) (Notes 1, 2)

PARAMETER	SYMBOL	CONDITIONS	MIN	TYP	MAX	UNITS
AUTOMATIC POWER AND EXTINCTION RATIO CONTROLS						
Monitor-Diode Input Current Range	I _{MD}	Average current into the MD pin	18		1500	μA
MD Pin Voltage					1.4	V
MD Current Monitor Ratio		I _{MD} / I _{PC_MON}	0.85	0.93	1.15	mA/mA
APC Loop Time Constant		C _{APC_FILT} = 0.01μF, ΔI _{MD} / ΔI _{BIAS} = 1/70		3.3		μs
APC Setting Stability		(Note 6)		±100	±480	ppm/°C
APC Setting Accuracy		T _A = +25°C			±15	%
I _{MOD} Compensation-Setting Range by Bias	K	K = ΔI _{MOD} / ΔI _{BIAS}	0		1.5	mA/mA
I _{MOD} Compensation-Setting Range by Temperature	TC	TC = ΔI _{MOD} / ΔT (Note 6)	0		1.0	mA/°C
Threshold-Setting Range for Temperature Compensation	T _{TH}	(Note 6)	+10		+60	°C
LASER SAFETY AND CONTROL						
Bias and Modulation Turn-Off Delay		C _{APC_FILT} = 0.01μF, ΔI _{MD} / ΔI _{BIAS} = 1/80 (Note 6)			5	μs
Bias and Modulation Turn-On Delay		C _{APC_FILT} = 0.01μF, ΔI _{MD} / ΔI _{BIAS} = 1/80 (Note 6)			600	μs
Threshold Voltage at Monitor Pins	V _{REF}	Figure 5	1.14	1.3	1.39	V
INTERFACE SIGNALS						
TX_DISABLE Input High	V _{HI}		2.0			V
TX_DISABLE Input Low	V _{LO}	R _{PULL} = 45kΩ (typical)			0.8	V
TX_DISABLE Input Current		V _{HI} = V _{CC}			15	μA
		V _{LO} = GND		-70	-140	
TX_FAULT Output Low		Sinking 1mA, open collector			0.4	V
Shutdown Output High		Sourcing 100μA	V _{CC} - 0.4			V
Shutdown Output Low		Sinking 100μA			0.4	V

Note 1: AC characterization is performed using the circuit in Figure 2 using a PRBS 2²³ - 1 or equivalent pattern.

Note 2: Specifications at -40°C are guaranteed by design and characterization.

Note 3: Excluding I_{BIAS} and I_{MOD}. Input data is AC-coupled. TX_FAULT open, SHUTDOWN open.

Note 4: Power-supply noise rejection (PSNR) = 20log₁₀(V_{noise} (on V_{CC}) / ΔV_{OUT}). V_{OUT} is the voltage across the 15Ω load when IN+ is high.

Note 5: The minimum required voltage at the OUT+ and OUT- pins is +0.75V.

Note 6: Guaranteed by design and characterization.

Note 7: Tested with 00001111 pattern at 622Mbps.

Note 8: DJ includes pulse-width distortion (PWD).

155Mbps to 622Mbps SFF/SFP Laser Driver with Extinction Ratio Control

Typical Operating Characteristics

($V_{CC} = +3.3V$, $C_{APC} = 0.01\mu F$, $I_{BIAS} = 20mA$, $I_{MOD} = 30mA$, $T_A = +25^\circ C$, unless otherwise noted.)

OPTICAL EYE DIAGRAM
(622.08Mbps, 2⁷ - 1 PRBS, 467MHz FILTER)

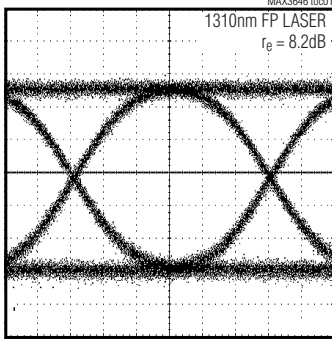

OPTICAL EYE DIAGRAM
(155Mbps, 2⁷ - 1 PRBS, 117MHz FILTER)

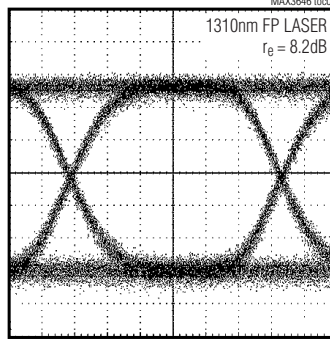

ELECTRICAL EYE DIAGRAM
($I_{MOD} = 30mA$, 622.08MHz, 2⁷ - 1 PRBS)

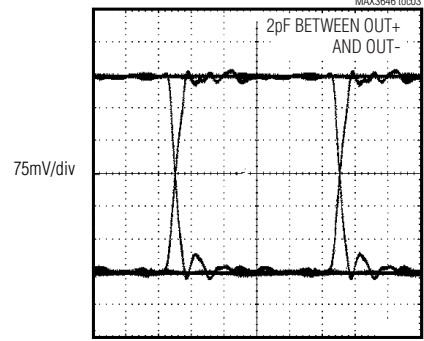

SUPPLY CURRENT (I_{CC}) vs. TEMPERATURE
(EXCLUDES BIAS AND MODULATION CURRENTS)

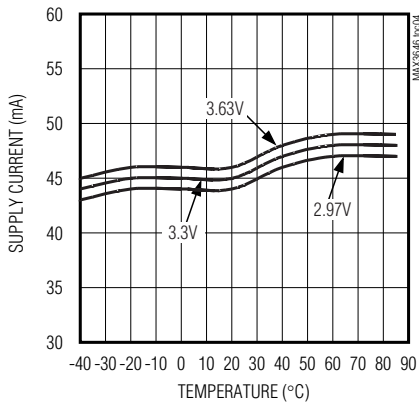

BIAS-CURRENT MONITOR RATIO vs. TEMPERATURE

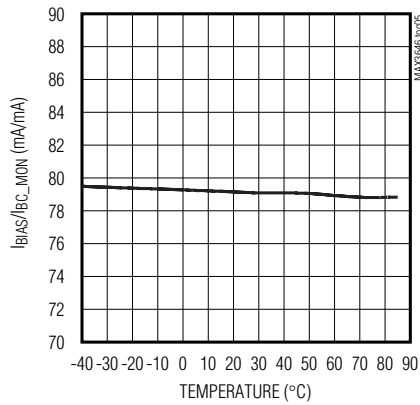

PHOTOCURRENT MONITOR RATIO vs. TEMPERATURE

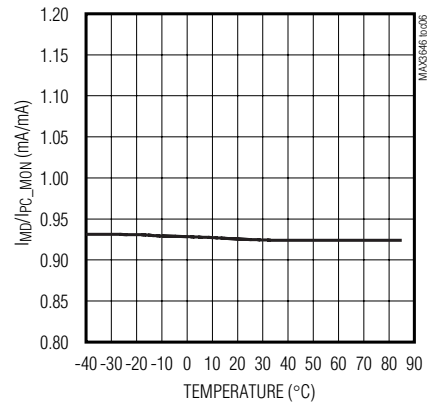

MODULATION CURRENT vs. R_{MODSET}

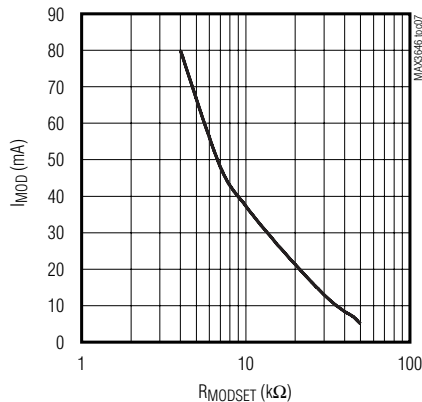

PHOTODIODE CURRENT vs. R_{APCSET}

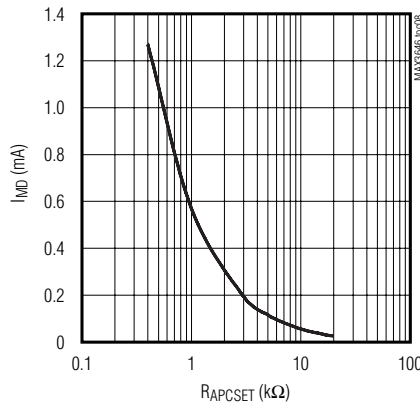

DETERMINISTIC JITTER vs. MODULATION CURRENT

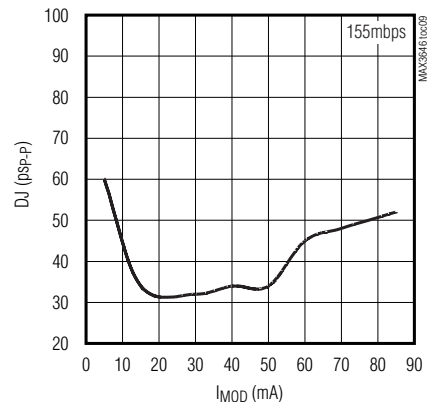

155Mbps to 622Mbps SFF/SFP Laser Driver with Extinction Ratio Control

Typical Operating Characteristics (continued)

($V_{CC} = +3.3V$, $C_{APC} = 0.01\mu F$, $I_{BIAS} = 20mA$, $I_{MOD} = 30mA$, $T_A = +25^\circ C$, unless otherwise noted.)

MAX3646

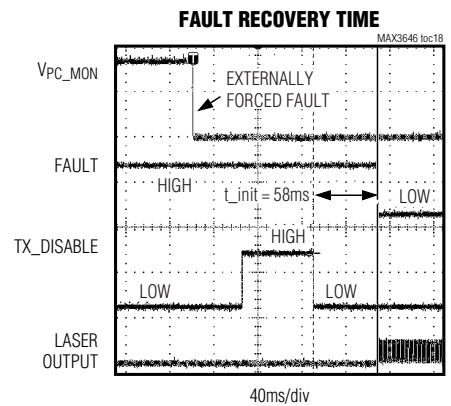
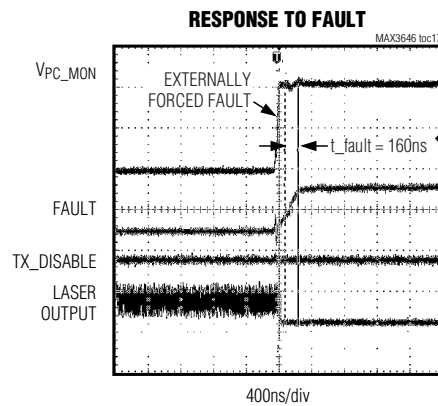
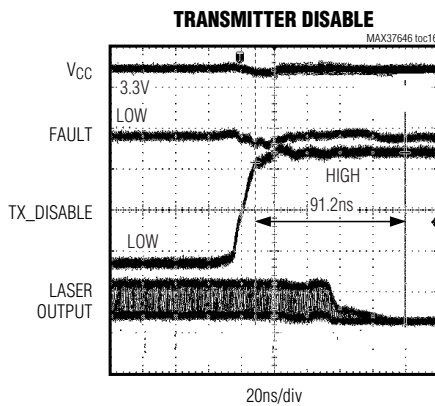
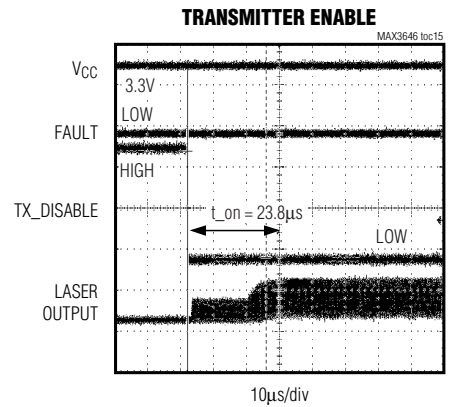
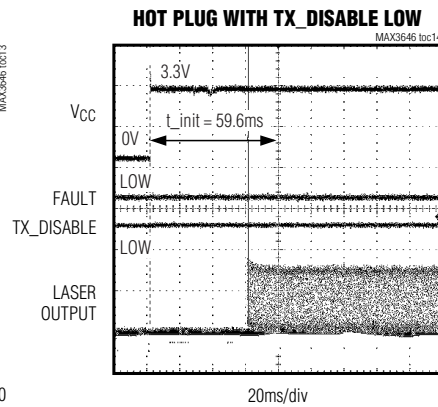
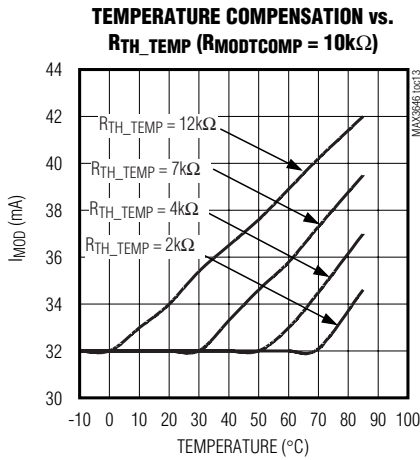
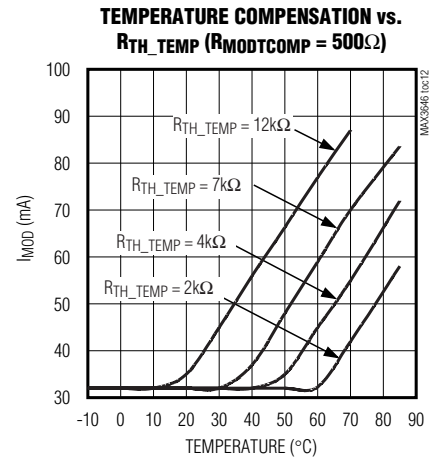
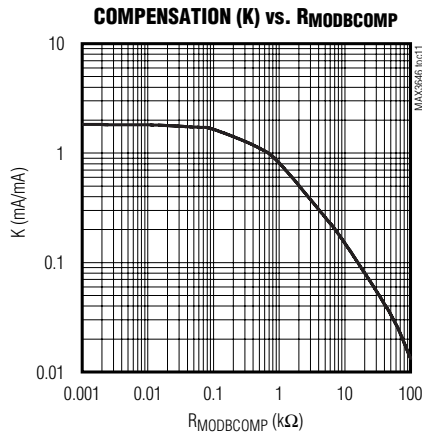
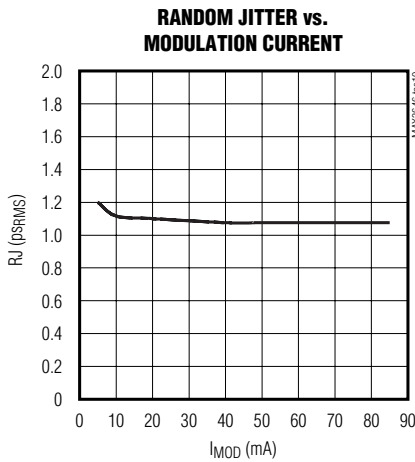

155Mbps to 622Mbps SFF/SFP Laser Driver with Extinction Ratio Control

Pin Description

PIN	NAME	FUNCTION
1	MODTCOMP	Modulation-Current Compensation from Temperature. A resistor at this pin sets the temperature coefficient of the modulation current when above the threshold temperature. Leave open for zero temperature compensation.
2, 5, 14, 17	VCC	+3.3V Supply Voltage
3	IN+	Noninverted Data Input
4	IN-	Inverted Data Input
6	TX_DISABLE	Transmitter Disable, TTL. Laser output is disabled when TX_DISABLE is asserted high or left unconnected. The laser output is enabled when this pin is asserted low.
7	PC_MON	Photodiode-Current Monitor Output. Current out of this pin develops a ground-referenced voltage across an external resistor that is proportional to the monitor diode current.
8	BC_MON	Bias-Current Monitor Output. Current out of this pin develops a ground-referenced voltage across an external resistor that is proportional to the bias current.
9	SHUTDOWN	Shutdown Driver Output. Voltage output to control an external transistor for optional shutdown circuitry.
10, 12	GND	Ground
11	TX_FAULT	Open-Collector Transmit Fault Indicator (Table 1)
13	BIAS	Laser Bias-Current Output
15	OUT-	Inverted Modulation-Current Output. I _{MOD} flows into this pin when input data is low.
16	OUT+	Noninverted Modulation-Current Output. I _{MOD} flows into this pin when input data is high.
18	MD	Monitor Photodiode Input. Connect this pin to the anode of a monitor photodiode. A capacitor to ground is required to filter the high-speed AC monitor photocurrent.
19	APCFILT1	Connect a capacitor (C _{APC}) between pin 19 (APCFILT1) and pin 20 (APCFILT2) to set the dominant pole of the APC feedback loop.
20	APCFILT2	(See Pin 19)
21	APCSET	A resistor connected from this pin to ground sets the desired average optical power. The total capacitive load at the APCSET pin should be no more than 10pF. Minimize metal resistance for ground connections.
22	MODSET	A resistor connected from this pin to ground sets the desired constant portion of the modulation current. The total capacitive load at the MODSET pin should be no more than 10pF. Minimize metal resistance for ground connections.
23	MODBCOMP	Modulation-Current Compensation from Bias. Couples the bias current to the modulation current. Mirrors I _{BIAS} through an external resistor. Leave open for zero-coupling.
24	TH_TEMP	Threshold for Temperature Compensation. A resistor at this pin programs the temperature above which compensation is added to the modulation current.
—	EP	Exposed Pad. Solder the exposed pad to the circuit board ground for specified thermal and electrical performance.

155Mbps to 622Mbps SFF/SFP Laser Driver with Extinction Ratio Control

MAX3646

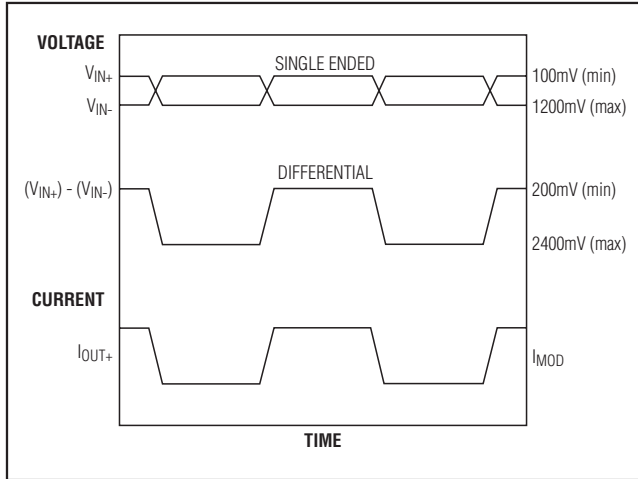

Figure 1. Required Input Signal and Output Polarity

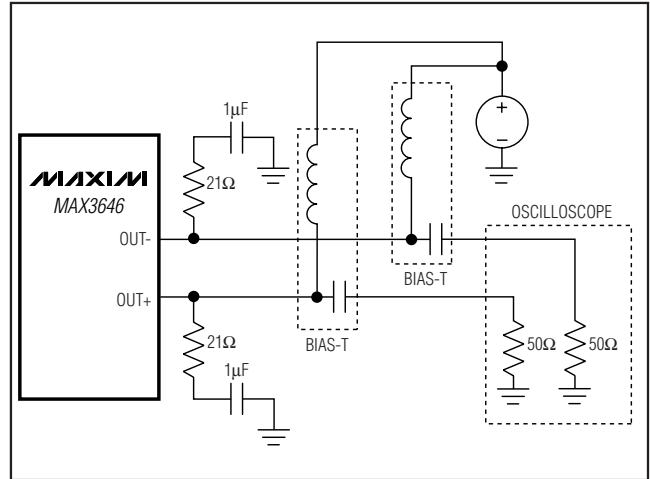

Figure 2. Test Circuit for Characterization

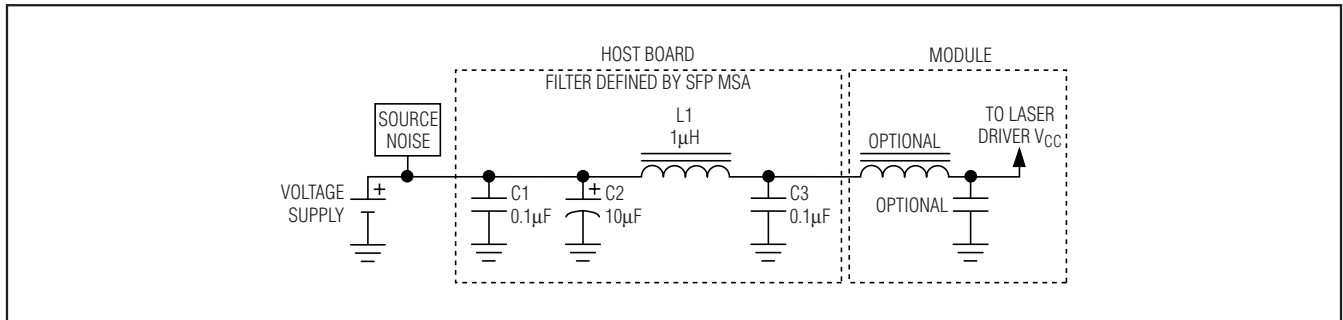

Figure 3. Supply Filter

Detailed Description

The MAX3646 laser driver consists of three main parts: a high-speed modulation driver, biasing block with ERC, and safety circuitry. The circuit design is optimized for high-speed, low-voltage (+3.3V) operation (Figure 4).

High-Speed Modulation Driver

The output stage is composed of a high-speed differential pair and a programmable modulation current source. The MAX3646 is optimized for driving a 15Ω load. The minimum instantaneous voltage required at OUT- is 0.7V for modulation currents up to 60mA and 0.75V for currents from 60mA to 85mA. Operation above 60mA can be accomplished by AC-coupling or with sufficient voltage at the laser to meet the driver output voltage requirement.

To interface with the laser diode, a damping resistor (RD) is required. The combined resistance damping

resistor and the equivalent series resistance (ESR) of the laser diode should equal 15Ω. To further damp aberrations caused by laser diode parasitic inductance, an RC shunt network may be necessary. Refer to Application Note 274: *HFAN-02.0: Interfacing Maxim Laser Drivers with Laser Diodes* for more information.

Any capacitive load at the cathode of a laser diode degrades optical output performance. Because the BIAS output is directly connected to the laser cathode, minimize the parasitic capacitance associated with the pin by using an inductor to isolate the BIAS pin parasitics from the laser cathode.

Extinction Ratio Control

The extinction ratio (r_e) is the laser on-state power divided by the off-state power. Extinction ratio remains constant if peak-to-peak and average power are held constant:

$$r_e = (2PAVG + PP-P) / (2PAVG - PP-P)$$

155Mbps to 622Mbps SFF/SFP Laser Driver with Extinction Ratio Control

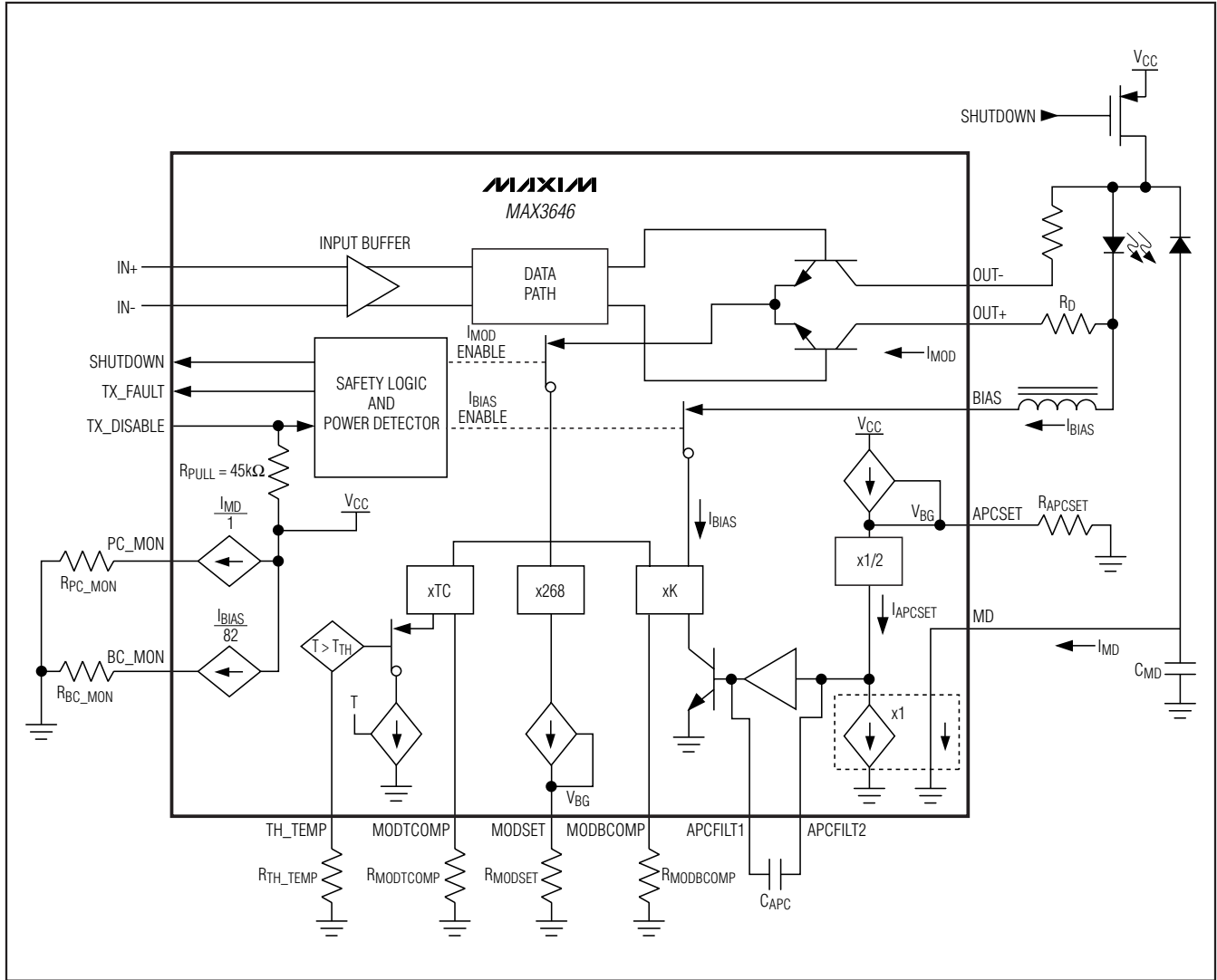

Figure 4. Functional Diagram

Average power is regulated using APC, which keeps constant current from a photodiode coupled to the laser. Peak-to-peak power is maintained by compensating the modulation current for reduced slope efficiency (η) of laser over time and temperature:

$$P_{AVG} = I_{MOD}/\rho_{MON}$$

$$P_{P-P} = \eta \times I_{MOD}$$

Modulation compensation from bias increases the modulation current by a user-selected proportion (K) needed to maintain peak-to-peak laser power as bias current

increases with temperature. Refer to Application Note 1119: *HFAN-02.2.1: Maintaining the Extinction Ratio of Optical Transmitters Using K-Factor Control* for details:

$$K = \Delta I_{MOD} / \Delta I_{BIAS}$$

This provides a first-order approximation of the current increase needed to maintain peak-to-peak power. Slope efficiency decreases more rapidly as temperature increases. The MAX3646 provides additional temperature compensation as temperature increases past a user-defined threshold (T_{TH}).

155Mbps to 622Mbps SFF/SFP Laser Driver with Extinction Ratio Control

MAX3646

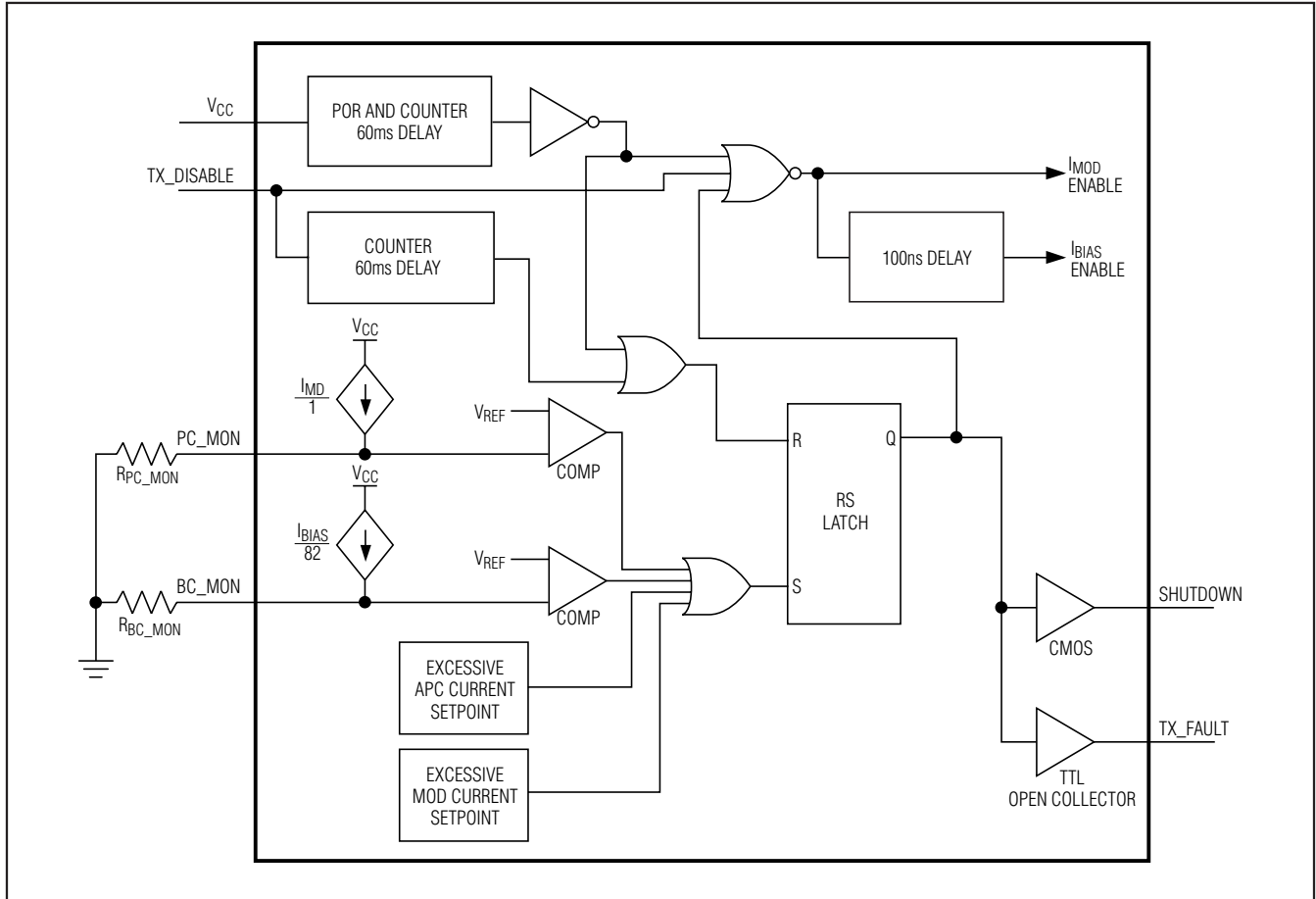

Figure 5. Simplified Safety Circuit

Table 1. Typical Fault Conditions

1	If any of the I/O pins are shorted to GND or VCC (single-point failure; see Table 2), and the bias current or the photocurrent exceeds the programmed threshold.
2	End-of-life (EOL) condition of the laser diode. The bias current and/or the photocurrent exceed the programmed threshold.
3	Laser cathode is grounded and photocurrent exceeds the programming threshold.
4	No feedback for the APC loop (broken interconnection, defective monitor photodiode), and the bias current exceeds the programmed threshold.

155Mbps to 622Mbps SFF/SFP Laser Driver with Extinction Ratio Control

Table 2. Circuit Responses to Various Single-Point Faults

PIN	CIRCUIT RESPONSE TO OVERVOLTAGE OR SHORT TO V _{CC}	CIRCUIT RESPONSE TO UNDERVOLTAGE OR SHORT TO GROUND
TX_FAULT	Does not affect laser power.	Does not affect laser power.
TX_DISABLE	Modulation and bias currents are disabled.	Normal condition for circuit operation.
IN+	The optical average power increases and a fault occurs if V _{PC_MON} exceeds the threshold. The APC loop responds by decreasing the bias current.	The optical average power decreases and the APC loop responds by increasing the bias current. A fault state occurs if V _{BC_MON} exceeds the threshold voltage.
IN-	The optical average power decreases and the APC loop responds by increasing the bias current. A fault state occurs if V _{BC_MON} exceeds the threshold voltage.	The optical average power increases and a fault occurs if V _{PC_MON} exceeds the threshold. The APC loop responds by decreasing the bias current.
MD	This disables bias current. A fault state occurs.	The APC circuit responds by increasing the bias current until a fault is detected, then a fault* state occurs.
SHUTDOWN	Does not affect laser power. If the shutdown circuitry is used, the laser current is disabled.	Does not affect laser power.
BIAS	In this condition, the laser forward voltage is 0V and no light is emitted.	Fault state* occurs. If the shutdown circuitry is used, the laser current is disabled.
OUT+	The APC circuit responds by increasing the bias current until a fault is detected, then a fault state* occurs.	Fault state* occurs. If the shutdown circuitry is used, the laser current is disabled.
OUT-	Does not affect laser power.	Does not affect laser power.
PC_MON	Fault state* occurs.	Does not affect laser power.
BC_MON	Fault state* occurs.	Does not affect laser power.
APCFILT1	I _{BIAS} increases until V _{BC_MON} exceeds the threshold voltage.	I _{BIAS} increases until V _{BC_MON} exceeds the threshold voltage.
APCFILT2	I _{BIAS} increases until V _{BC_MON} exceeds the threshold voltage.	I _{BIAS} increases until V _{BC_MON} exceeds the threshold voltage.
MODSET	Does not affect laser power.	Fault state* occurs.
APCSET	Does not affect laser power.	Fault state* occurs.

*A fault state asserts the TX_FAULT pin, disables the modulation and bias currents, and asserts the SHUTDOWN pin.

155Mbps to 622Mbps SFF/SFP Laser Driver with Extinction Ratio Control

Table 3. Optical Power Relations

PARAMETER	SYMBOL	RELATION
Average power	P_{AVG}	$P_{AVG} = (P_0 + P_1) / 2$
Extinction ratio	r_e	$r_e = P_1 / P_0$
Optical power of a one	P_1	$P_1 = 2P_{AVG} \times r_e / (r_e + 1)$
Optical power of a zero	P_0	$P_0 = 2P_{AVG} / (r_e + 1)$
Optical amplitude	P_{P-P}	$P_{P-P} = P_1 - P_0$
Laser slope efficiency	η	$\eta = P_{P-P} / I_{MOD}$
Modulation current	I_{MOD}	$I_{MOD} = P_{P-P} / \eta$
Threshold current	I_{TH}	P_0 at $I \geq I_{TH}$
Bias current (AC-coupled)	I_{BIAS}	$I_{BIAS} \geq I_{TH} + I_{MOD} / 2$
Laser to monitor transfer	ρ_{MON}	I_{MD} / P_{AVG}

Note: Assuming a 50% average input duty cycle and mark density.

Safety Circuitry

The safety circuitry contains a disable input (TX_DISABLE), a latched fault output (TX_FAULT), and fault detectors (Figure 5). This circuitry monitors the operation of the laser driver and forces a shutdown if a fault is detected (Table 1). The TX_FAULT pin should be pulled high with a 4.7k Ω to 10k Ω resistor to V_{CC} as required by the SFP MSA. A single-point fault can be a short to V_{CC} or GND. See Table 2 to view the circuit response to various single-point failure. The transmit fault condition is latched until reset by a toggle or TX_DISABLE or V_{CC}. The laser driver offers redundant laser diode shutdown through the optional shutdown circuitry as shown in the *Typical Application Circuit*. This shutdown transistor prevents a single-point fault at the laser from creating an unsafe condition.

Safety Circuitry Current Monitors

The MAX3646 features monitors (BC_MON, PC_MON) for bias current (I_{BIAS}) and photocurrent (I_{MD}). The monitors are realized by mirroring a fraction of the currents and developing voltages across external resistors connected to ground. Voltages greater than V_{REF} at PC_MON or BC_MON result in a fault state. For example, connecting a 100 Ω resistor to ground at each monitor output gives the following relationships:

$$V_{BC_MON} = (I_{BIAS} / 82) \times 100\Omega$$

$$V_{PC_MON} = I_{MD} \times 100\Omega$$

External sense resistors can be used for high-accuracy measurement of bias and photodiode currents. On-chip

isolation resistors are included to reduce the number of components needed to implement this function.

Design Procedure

When designing a laser transmitter, the optical output is usually expressed in terms of average power and extinction ratio. Table 3 shows relationships that are helpful in converting between the optical average power and the modulation current. These relationships are valid if the mark density and duty cycle of the optical waveform are 50%.

For a desired laser average optical power (P_{AVG}) and optical extinction ratio (r_e), the required bias and modulation currents can be calculated using the equations in Table 3. Proper setting of these currents requires knowledge of the laser to monitor transfer (ρ_{MON}) and slope efficiency (η).

Programming the Monitor-Diode Current Set Point

The MAX3646 operates in APC mode at all times. The bias current is automatically set so average laser power is determined by the APCSET resistor:

$$P_{AVG} = I_{MD} / \rho_{MON}$$

The APCSET pin controls the set point for the monitor diode current. An internal current regulator establishes the APCSET current in the same manner as the MODSET pin. See the I_{MD} vs. R_{APCSET} graph in the *Typical Operating Characteristics* and select the value of R_{APCSET} that corresponds to the required current at +25°C:

$$I_{MD} = 1/2 \times V_{REF} / R_{APCSET}$$

The laser driver automatically adjusts the bias to maintain the constant average power. For DC-coupled laser diodes:

$$I_{AVG} = I_{BIAS} + I_{MOD} / 2$$

Programming the Modulation Current with Compensation

Determine the modulation current from the laser slope efficiency:

$$I_{MOD} = 2 \times P_{AVG} / \eta \times (r_e - 1) / (r_e + 1)$$

The modulation current of the MAX3646 consists of a static modulation current (I_{MODS}), a current proportional to I_{BIAS}, and a current proportional to temperature. The portion of I_{MOD} set by MODSET is established by an internal current regulator, which maintains the reference voltage of V_{REF} across the external programming resistor. See the I_{MOD} vs. R_{MODSET} graph in the *Typical Operating Characteristics* and select the value

155Mbps to 622Mbps SFF/SFP Laser Driver with Extinction Ratio Control

of R_{MODSET} that corresponds to the required current at +25°C:

$$I_{MOD} = I_{MODS} + K \times I_{BIAS} + I_{MODT}$$

$$I_{MODS} = 268 \times V_{REF} / R_{MODSET}$$

$$I_{MODT} = TC \times (T - T_{TH}) \quad | T > T_{TH}$$

$$I_{MODT} = 0 \quad | T \leq T_{TH}$$

An external resistor at the MODBCOMP pin sets current proportional to I_{BIAS}. Open circuiting the MODBCOMP pin can turn off the interaction between I_{BIAS} and I_{MOD}:

$$K = 1700 / (1000 + R_{MODBCOMP}) \pm 10\%$$

If I_{MOD} must be increased from I_{MOD1} to I_{MOD2} to maintain the extinction ratio at elevated temperatures, the required compensation factor is:

$$K = (I_{MOD2} - I_{MOD1}) / (I_{BIAS2} - I_{BIAS1})$$

A threshold for additional temperature compensation can be set with a programming resistor at the TH_TEMP pin:

$$T_{TH} = -70^{\circ}\text{C} + 1.45\text{M}\Omega / (9.2\text{k}\Omega + R_{TH_TEMP})^{\circ}\text{C} \pm 10\%$$

The temperature coefficient of thermal compensation above T_{TH} is set by R_{MODTCOMP}. Leaving the MODTCOMP pin open disables additional thermal compensation:

$$TC = 1 / (0.5 + R_{MODTCOMP}(\text{k}\Omega)) \text{ mA}^{\circ}\text{C} \pm 10\%$$

Current Compliance (I_{MOD} ≤ 60mA), DC-Coupled

The minimum voltage at the OUT+ and OUT- pins is 0.7V.

For:

V_{DIODE} = Diode bias point voltage (1.2V typ)

R_L = Diode bias point resistance (5Ω typ)

R_D = Series matching resistor (20Ω typ)

For compliance:

$$V_{OUT+} = V_{CC} - V_{DIODE} - I_{MOD} \times (R_D + R_L) - I_{BIAS} \times R_L \geq 0.7\text{V}$$

Current Compliance (I_{MOD} > 60mA), AC-Coupled

For applications requiring modulation current greater than 60mA, headroom is insufficient from proper operation of the laser driver if the laser is DC-coupled. To avoid this problem, the MAX3646's modulation output can be AC-coupled to the cathode of a laser diode. An external pullup inductor is necessary to DC-bias the modulation output at V_{CC}. Such a configuration isolates laser forward voltage from the output circuitry and allows the output at OUT+ to swing above and below the supply voltage (V_{CC}). When AC-coupled, the MAX3646 modulation current can be programmed up to 85mA. Refer to Application Note 274: HFAN-02.0: Interfacing

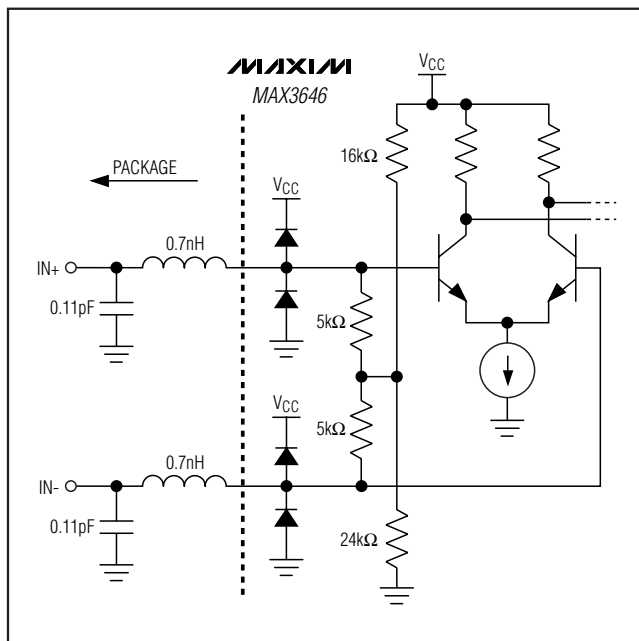

Figure 6. Simplified Input Structure

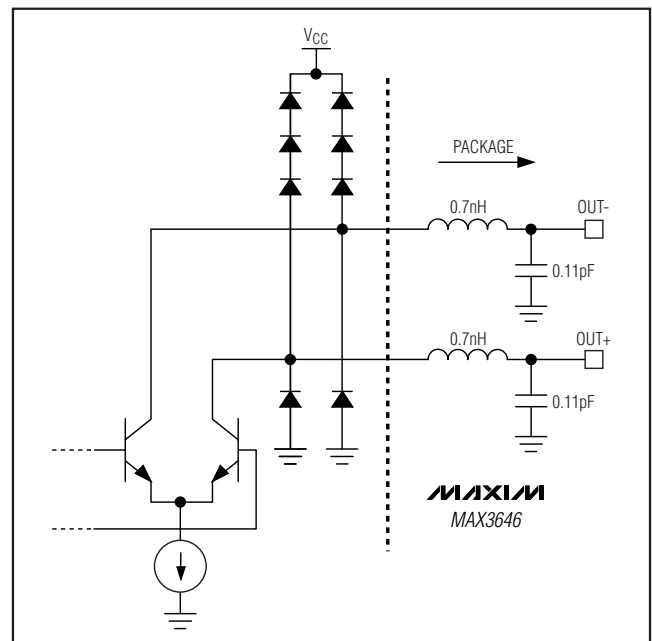

Figure 7. Simplified Output Structure

155Mbps to 622Mbps SFF/SFP Laser Driver with Extinction Ratio Control

Maxim Laser Drivers with Laser Diodes for more information on AC-coupling laser drivers to laser diodes.

For compliance:

$$V_{OUT+} = V_{CC} - I_{MOD} / 2 \times (R_D + R_L) \geq 0.75V$$

Determine CAPC

The APC loop filter capacitor (C_{APC}) must be selected to balance the requirements for fast turn-on and minimal interaction with low frequencies in the data pattern. The low-frequency cutoff is:

$$C_{APC}(\mu F) \cong 68 / (f_{3dB}(kHz) \times (\eta \times \rho_{MON}))^{1.1}$$

High-frequency noise can be filtered with an additional cap, C_{MD} , from the MD pin to ground:

$$C_{MD} \cong C_{APC} / 4$$

The MAX3646 is designed so turn-on time is faster than 1ms for most laser gain values ($\eta \times \rho_{MON}$). Choosing a smaller value of C_{APC} reduces turn-on time. Careful balance between turn-on time and low-frequency cutoff may be needed at low data rates for some values of laser gain.

Interface Models

Figures 6 and 7 show simplified input and output circuits for the MAX3646 laser driver. If dice are used, replace package parasitic elements with bondwire parasitic elements.

Layout Considerations

To minimize loss and crosstalk, keep the connections between the MAX3646 output and the laser diode as short as possible. Use good high-frequency layout

techniques and multilayer boards with uninterrupted ground plane to minimize EMI and crosstalk. Circuit boards should be made using low-loss dielectrics. Use controlled-impedance lines for data inputs, as well as the module output.

Laser Safety and IEC 825

Using the MAX3646 laser driver alone does not ensure that a transmitter design is IEC 825 compliant. The entire transmitter circuit and component selections must be considered. Each customer must determine the level of fault tolerance required by their application, recognizing that Maxim products are not designed or authorized for use as components in systems intended for surgical implant into the body, for applications intended to support or sustain life, or for any other application where the failure of a Maxim product could create a situation where personal injury or death may occur.

Exposed-Pad (EP) Package

The exposed pad on the 24-pin QFN provides a very low thermal resistance path for heat removal from the IC. The pad is also electrical ground on the MAX3646 and should be soldered to the circuit board ground for proper thermal and electrical performance. Refer to Application Note 862: *HFAN-08.1: Thermal Consideration of QFN and Other Exposed-Paddle Packages* at www.maxim-ic.com for additional information.

Chip Information

PROCESS: SiGe/BIPOLAR

155Mbps to 622Mbps SFF/SFP Laser Driver with Extinction Ratio Control

Typical Application Circuit

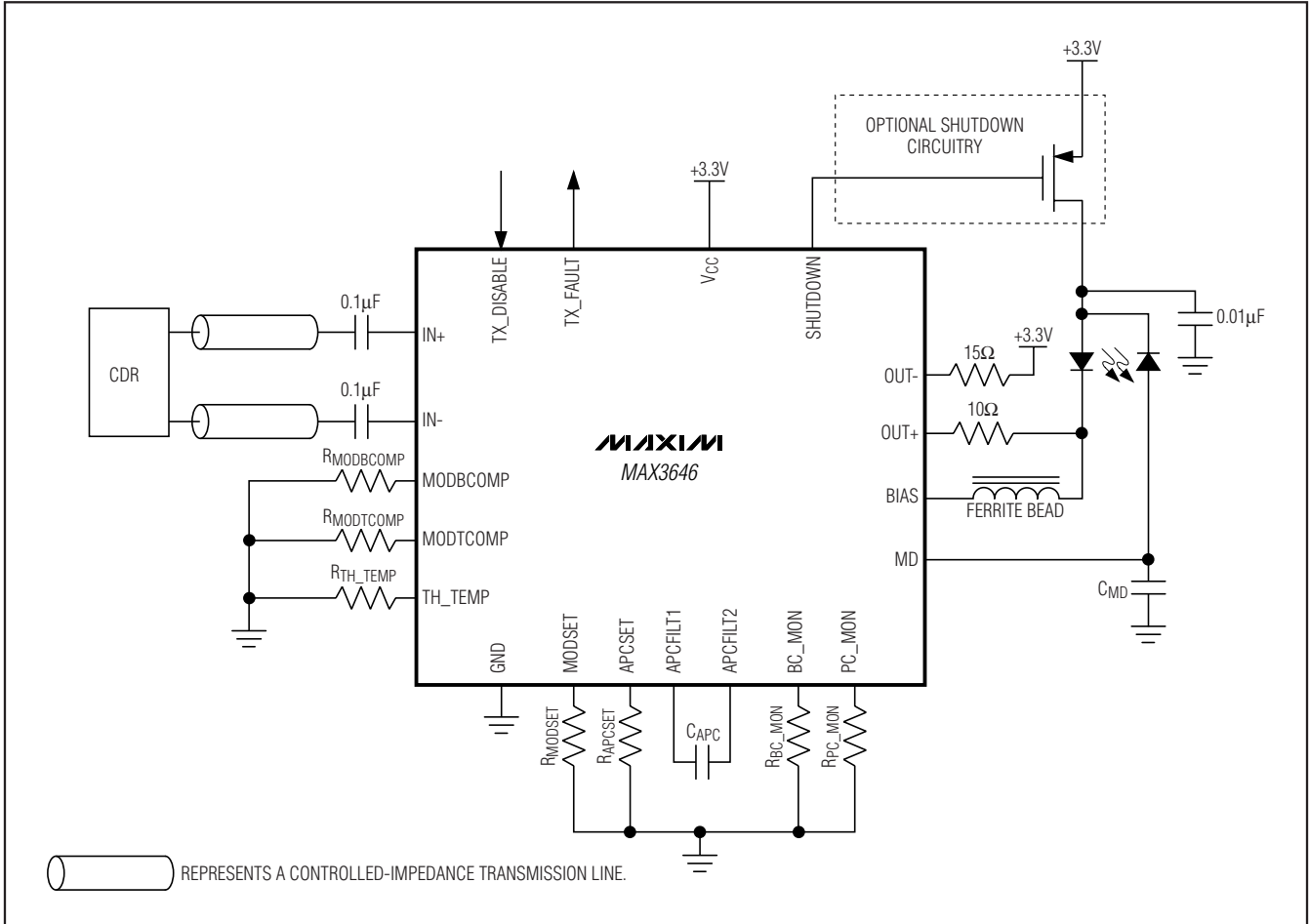

Package Information

For the latest package outline information and land patterns (footprints), go to www.maxim-ic.com/packages. Note that a "+", "#", or "-" in the package code indicates RoHS status only. Package drawings may show a different suffix character, but the drawing pertains to the package regardless of RoHS status.

PACKAGE TYPE	PACKAGE CODE	OUTLINE NO.	LAND PATTERN NO.
24 TQFN-EP	T2444-3	21-0139	90-0021