

MAX3735A

2.7Gbps, Low-Power SFP Laser Driver

General Description

The MAX3735A is a +3.3V laser driver for SFP/SFF applications from 155Mbps up to 2.7Gbps. The device accepts differential input data and provides bias and modulation currents for driving a laser. DC-coupling to the laser allows for multirate applications and reduces the number of external components. The MAX3735A is fully compliant with the SFP MSA timing and the SFF-8472 transmit diagnostic requirements.

An automatic power-control (APC) feedback loop is incorporated to maintain a constant average optical power over temperature and lifetime. The wide modulation current range of 10mA to 60mA (up to 85mA AC-coupled) and bias current of 1mA to 100mA make this product ideal for driving FP/DFB laser diodes in fiber-optic modules. The resistor range for the laser current settings is optimized to interface with the DS1858 SFP controller IC.

The MAX3735A provides transmit-disable control, a single-point latched transmit-failure monitor output, photo-current monitoring, and bias-current monitoring to indicate when the APC loop is unable to maintain the average optical power.

The MAX3735A is available in a 4mm x 4mm TQFN package and operates over the extended temperature range of -40°C to +85°C.

Applications

- Gigabit Ethernet SFP/SFF Transceiver Modules
- 1G/2G Fibre Channel SFP/SFF Transceiver Modules
- Multirate OC3 to OC48-FEC SFP/SFF Transceiver Modules

Typical Application Circuit

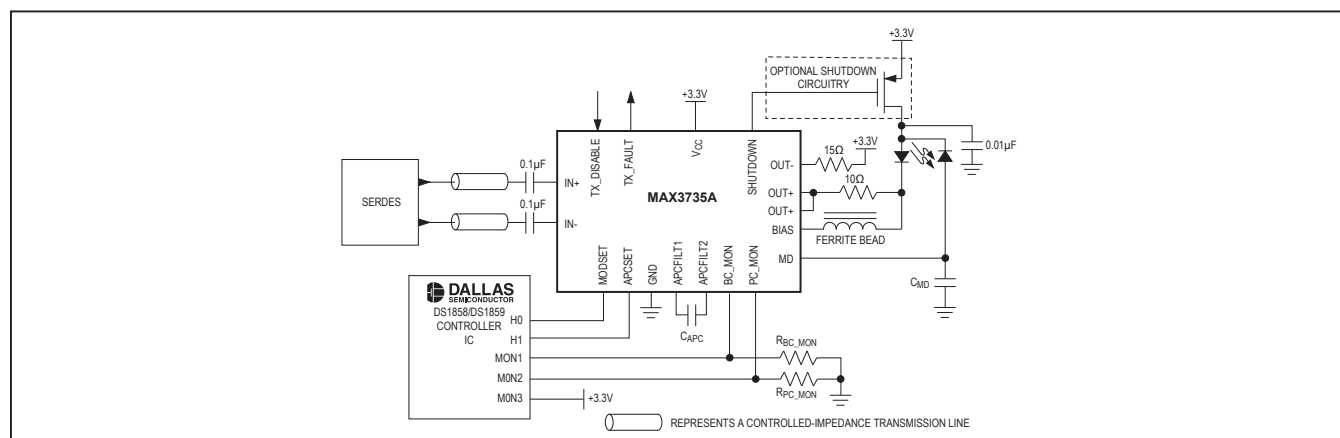

Features

- Fully Compliant with SFP and SFF-8472 MSAs
- Programmable Modulation Current from 10mA to 60mA (DC-Coupled)
- Programmable Modulation Current from 10mA to 85mA (AC-Coupled)
- Programmable Bias Current from 1mA to 100mA
- Edge Transition Times <51ps
- 27mA (typ) Power-Supply Current
- Multirate 155Mbps to 2.7Gbps Operation
- Automatic Average Power Control
- On-Chip Pullup Resistor for TX_DISABLE
- 24-Pin 4mm x 4mm TQFN package

Ordering Information appears at end of data sheet.

Absolute Maximum Ratings

Supply Voltage, V_{CC} -0.5V to +6.0V
 Current into BIAS, OUT+, OUT-..... -20mA to +150mA
 Current into MD -5mA to +5mA
 Voltage at IN+, IN-, TX_DISABLE, TX_FAULT,
 SHUTDOWN..... -0.5V to ($V_{CC} + 0.5V$)
 Voltage at BIAS, PC_MON, BC_MON,
 MODSET, APCSET -0.5V to ($V_{CC} + 0.5V$)
 Voltage at OUT+, OUT-..... +0.5V to ($V_{CC} + 1.5V$)
 Voltage at APCFIL1, APCFIL2.....-0.5V to +3V

Continuous Power Dissipation ($T_A = +70^{\circ}C$)
 24-Lead Thin QFN (derate 27.8mW/ $^{\circ}C$
 above $+70^{\circ}C$)2222mW
 Operating Ambient Temperature Range (T_A)..... -40 $^{\circ}C$ to +85 $^{\circ}C$
 Storage Ambient Temperature Range..... -55 $^{\circ}C$ to +150 $^{\circ}C$
 Die Attach Temperature..... +400 $^{\circ}C$
 Lead Temperature (soldering, 10s) +300 $^{\circ}C$

Stresses beyond those listed under "Absolute Maximum Ratings" may cause permanent damage to the device. These are stress ratings only, and functional operation of the device at these or any other conditions beyond those indicated in the operational sections of the specifications is not implied. Exposure to absolute maximum rating conditions for extended periods may affect device reliability.

Package Information

PACKAGE TYPE: 24-PIN TQFN	
Package Code	T2444+3
Outline Number	21-0139
Land Pattern Number	90-0021

For the latest package outline information and land patterns (footprints), go to www.maximintegrated.com/packages. Note that a "+", "#", or "-" in the package code indicates RoHS status only. Package drawings may show a different suffix character, but the drawing pertains to the package regardless of RoHS status.

Electrical Characteristics

($V_{CC} = +2.97V$ to $+3.63V$, $T_A = -40^{\circ}C$ to $+85^{\circ}C$. Typical values at $V_{CC} = +3.3V$, $I_{BIAS} = 20mA$, $I_{MOD} = 30mA$, $T_A = +25^{\circ}C$, unless otherwise noted.) (Note 1)

PARAMETER	SYMBOL	CONDITIONS	MIN	TYP	MAX	UNITS
POWER SUPPLY						
Power-Supply Current	I_{CC}	Excludes the laser bias and modulation currents (Note 2)		27	50	mA
I/O SPECIFICATIONS						
Differential Input Voltage	V_{ID}	$V_{ID} = (V_{IN+}) - (V_{IN-})$, Figure 1	200		2400	mV _{P-P}
Common-Mode Input Voltage				$0.6 \times V_{CC}$		V
Differential Input Resistance			85	100	115	Ω
TX_DISABLE Input Pullup Resistance	R_{PULL}		4.7	7.4	10.0	k Ω
TX_DISABLE Input Current		$V_{HIGH} = V_{CC}$ $V_{LOW} = GND$, $V_{CC} = 3.3V$, $R_{PULL} = 7.4k\Omega$			15	μA
TX_DISABLE Input High Voltage	V_{IH}		2			V
TX_DISABLE Input Low Voltage	V_{IL}				0.8	V
TX_FAULT Output High Voltage	V_{OH}	$I_{OH} = 100\mu A$ sourcing (Note 3)	2.4			V
TX_FAULT Output Low Voltage	V_{OL}	$I_{OL} = 1mA$ sinking (Note 3)			0.4	V
SHUTDOWN Output High Voltage	V_{OH}	$I_{OH} = 100\mu A$ sourcing	$V_{CC} - 0.4$			V
SHUTDOWN Output Low Voltage	V_{OL}	$I_{OL} = 100\mu A$ sinking			0.4	V
BIAS GENERATOR						
Bias On-Current Range	I_{BIAS}	Current into BIAS pin	1		100	mA
Bias Off-Current	$I_{BIASOFF}$	Current into BIAS pin during TX_FAULT or TX_DISABLE			100	μA
Bias Overshoot		During SFP module hot plugging (Notes 4, 5, 11)			10	%
Bias-Current Monitor Gain	I_{BC_MON}	External resistor to GND defines the voltage gain, $I_{BIAS} = 1mA$, $R_{BC_MON} = 69.28k\Omega$ $I_{BIAS} = 100mA$, $R_{BC_MON} = 693.25\Omega$	10.0	12	13.5	mA/A
Bias-Current Monitor Gain Stability		$1mA \leq I_{BIAS} \leq 100mA$ (Notes 4, 6)	-6		+6	%
AUTOMATIC POWER-CONTROL LOOP						
MD Reverse Bias Voltage		$18\mu A \leq I_{MD} \leq 1500\mu A$	1.6			V
MD Average Current Range	I_{MD}	Average current into MD pin	18		1500	μA
Average Power-Setting Stability		APC closed loop (Notes 4, 7)				ppm/ $^{\circ}C$
		$I_{BIAS} = 1mA$	-110		+110	
		$I_{BIAS} = 100mA$	-650		+650	
Average Power Setting Accuracy		APC Closed Loop $1mA \leq I_{BIAS} \leq 100mA$ (Note 8)	-16		+16	%
MD-Current Monitor Gain	I_{PC_MON}	External resistor to GND defines the voltage gain; $I_{MD} = 18\mu A$, $R_{PC_MON} = 50k\Omega$ $I_{MD} = 1.5mA$, $R_{PC_MON} = 600\Omega$	0.9		1.1	A/A
MD-Current Monitor Gain Stability		$18\mu A \leq I_{MD} \leq 1500\mu A$ (Notes 4, 6)	-4		+4	%

Electrical Characteristics (continued)

($V_{CC} = +2.97V$ to $+3.63V$, $T_A = -40^{\circ}C$ to $+85^{\circ}C$. Typical values at $V_{CC} = +3.3V$, $I_{BIAS} = 20mA$, $I_{MOD} = 30mA$, $T_A = +25^{\circ}C$, unless otherwise noted.) (Note 1)

PARAMETER	SYMBOL	CONDITIONS	MIN	TYP	MAX	UNITS
LASER MODULATOR						
Modulation On-Current Range	I_{MOD}	Current into OUT+ pin; $R_L \leq 15\Omega$, V_{OUT+} , $V_{OUT-} \geq 0.6V$ (DC-coupled)	10		60	mA
		Current into OUT+ pin; $R_L \leq 15\Omega$, V_{OUT+} , $V_{OUT-} \geq 2.0V$ (AC-coupled)	10		85	
Modulation Off-Current	I_{MODOFF}	Current into OUT+ pin during TX_FAULT or TX_DISABLE			100	μA
Modulation-Current Stability (Note 4)		$I_{MOD} = 10mA$	-480		+480	ppm/ $^{\circ}C$
		$I_{MOD} = 60mA$	-255		+255	
Modulation-Current Absolute Accuracy		$10mA \leq I_{MOD} \leq 60mA$ (Note 8)	-15		+15	%
Modulation-Current Rise Time	t_R	20% to 80%, $10mA \leq I_{MOD} \leq 60mA$ (Note 4)		42	65	ps
Modulation-Current Fall Time	t_F	20% to 80%, $10mA \leq I_{MOD} \leq 60mA$ (Note 4)		50	80	ps
Deterministic Jitter		$10mA \leq I_{MOD} \leq 60mA$ at 2.67Gbps (Notes 4, 9, 10)		18	38	ps
		At 1.25Gbps (K28.5 pattern)		11.5		
		At 622Mbps (Note 9)		18		
		At 155Mbps (Note 9)		40		
Random Jitter	RJ	$10mA \leq I_{MOD} \leq 60mA$ (Note 4)		0.7	1.0	psRMS
SAFETY FEATURES						
Excessive Bias-Current Comparator Threshold Range		TX_FAULT always occurs for $V_{BC_MON} \geq 1.38V$, TX_FAULT never occurs for $V_{BC_MON} \leq 1.22V$	1.22	1.30	1.39	V
Excessive MD-Current Comparator Threshold Range		TX_FAULT always occurs for $V_{PC_MON} \geq 1.38V$, TX_FAULT never occurs for $V_{PC_MON} \leq 1.22V$	1.22	1.30	1.39	V
SFP TIMING REQUIREMENTS						
TX_DISABLE Assert Time	t_{off}	Time from rising edge of TX_DISABLE to $I_{BIAS} = I_{BIASOFF}$ and $I_{MOD} = I_{MODOFF}$ (Note 4)		0.14	5	μs
TX_DISABLE Negate Time	t_{on}	Time from falling edge of TX_DISABLE to I_{BIAS} and I_{MOD} at 95% of steady state when TX_FAULT = 0 before reset (Note 11)			600	μs

Electrical Characteristics (continued)

($V_{CC} = +2.97V$ to $+3.63V$, $T_A = -40^{\circ}C$ to $+85^{\circ}C$. Typical values at $V_{CC} = +3.3V$, $I_{BIAS} = 20mA$, $I_{MOD} = 30mA$, $T_A = +25^{\circ}C$, unless otherwise noted.) (Note 1)

PARAMETER	SYMBOL	CONDITIONS	MIN	TYP	MAX	UNITS
TX_DISABLE Negate Time During FAULT Recovery	$t_{onFAULT}$	Time from falling edge of TX_DISABLE to I_{BIAS} and I_{MOD} at 95% of steady state when TX_FAULT = 1 before reset (Note 4)		60	200	ms
TX_FAULT Reset Time or Power-On Time	t_{init}	From power-on or negation of TX_FAULT using TX_DISABLE (Note 4)		60	200	ms
TX_FAULT Assert Time	t_{fault}	Time from fault to TX_FAULT on, $C_{FAULT} \leq 20pF$, $R_{FAULT} = 4.7k\Omega$ (Note 4)		3.3	50	μs
TX_DISABLE to Reset		Time TX_DISABLE must be held high to reset TX_FAULT (Note 4)			5	μs

Note 1: Specifications at $-40^{\circ}C$ are guaranteed by design and characterization.

Note 2: Maximum value is specified at $I_{MOD} = 60mA$, $I_{BIAS} = 100mA$.

Note 3: TX_FAULT is an open-collector output and must be pulled up with a $4.7k\Omega$ to $10k\Omega$ resistor.

Note 4: Guaranteed by design and characterization.

Note 5: V_{CC} turn-on time must be $\leq 0.8s$, DC-coupled interface.

Note 6: Gain stability is defined by the digital diagnostic document (SFF-8472, rev. 9.0) over temperature and supply variation.

Note 7: Assuming that the laser diode to photodiode transfer function does not change with temperature.

Note 8: Accuracy refers to part-to-part variation.

Note 9: Deterministic jitter is measured using a $2^{23} - 1$ PRBS or equivalent pattern.

Note 10: Broadband noise is filtered through the network as shown in Figure 3. One capacitor, $C < 0.47\mu F$, and one 0603 ferrite bead or inductor can be added (optional). This supply voltage filtering reduces the hot-plugging inrush current. The supply noise must be $< 100mV_{P-P}$ up to 2MHz.

Note 11: C_{APC} values chosen as shown in [Table 4](#).

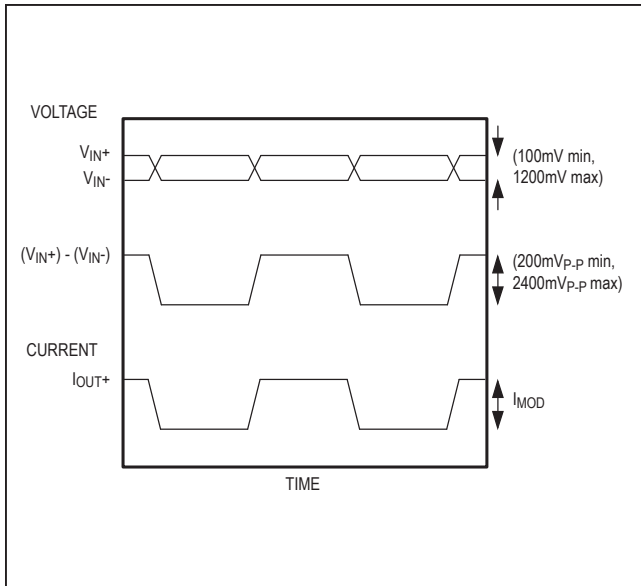

Figure 1. Required Input Signal and Output Polarity

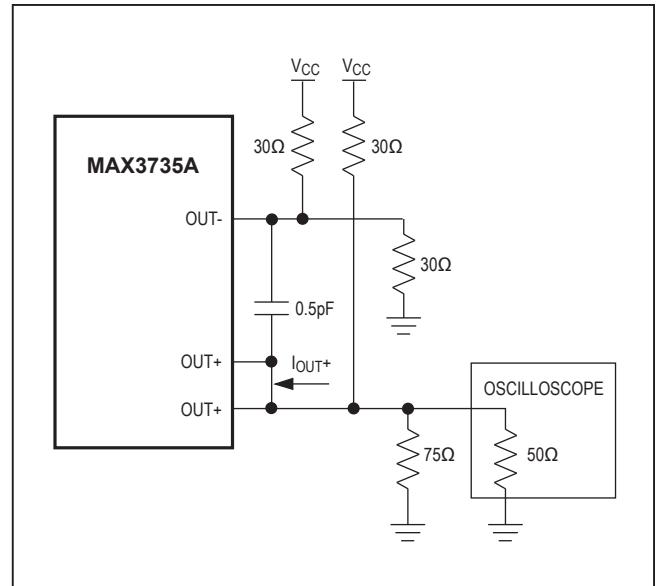

Figure 2. Output Termination for Characterization

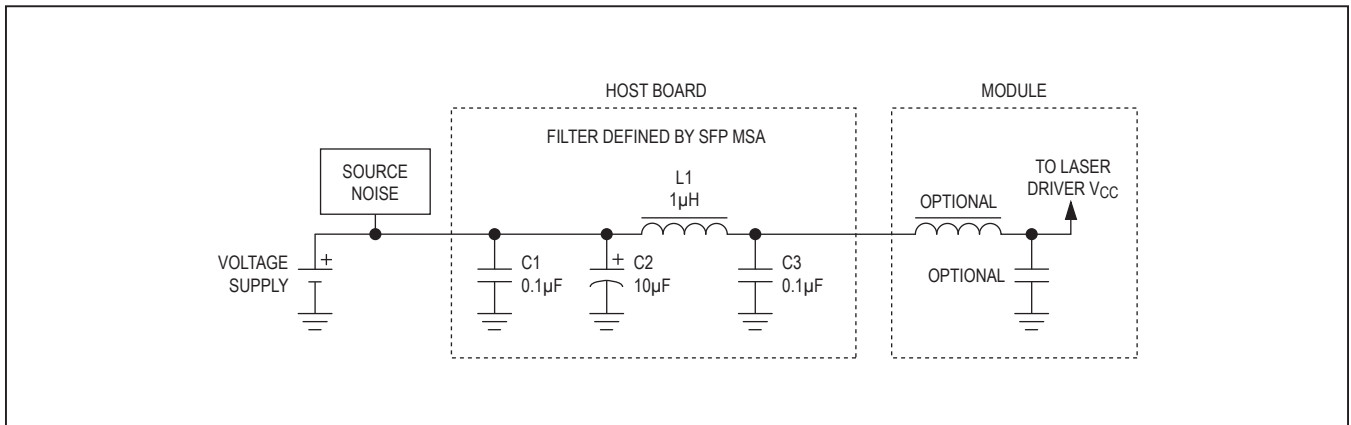
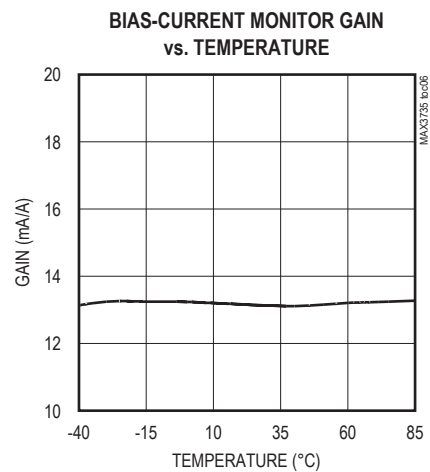
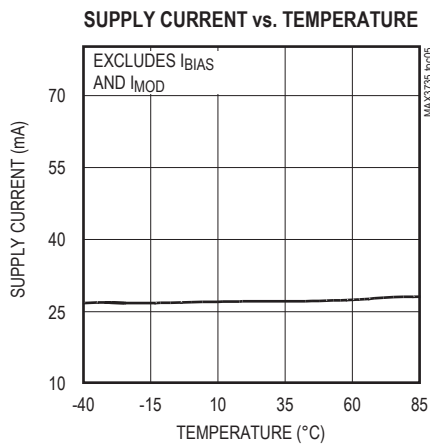
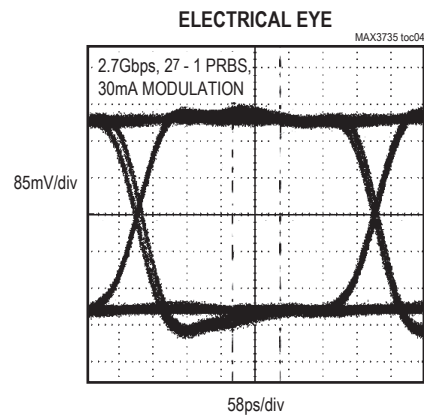
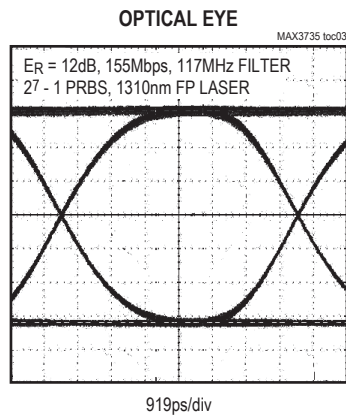
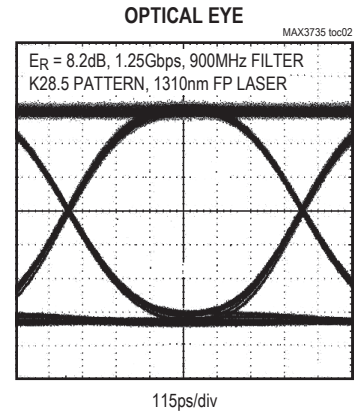
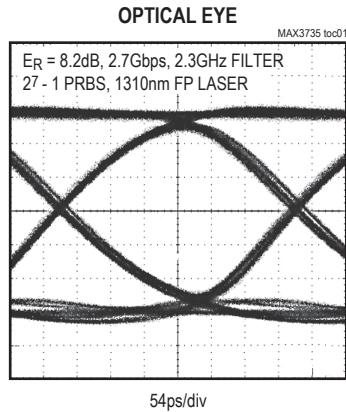

Figure 3. Supply Filter

Typical Operating Characteristics

($V_{CC} = +3.3V$, $C_{APC} = 0.01\mu F$, $I_{BIAS} = 20mA$, and $I_{MOD} = 30mA$, $T_A = +25^\circ C$, unless otherwise noted.)



Typical Operating Characteristics (continued)

($V_{CC} = +3.3V$, $C_{APC} = 0.01\mu F$, $I_{BIAS} = 20mA$, and $I_{MOD} = 30mA$, $T_A = +25^\circ C$, unless otherwise noted.)

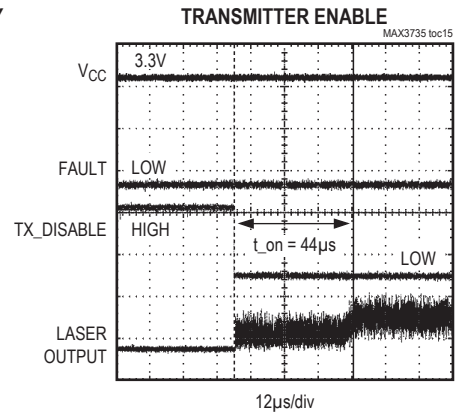
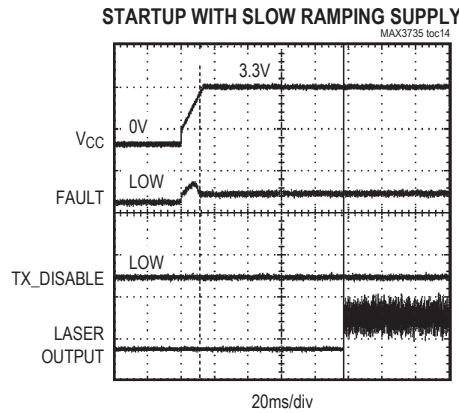
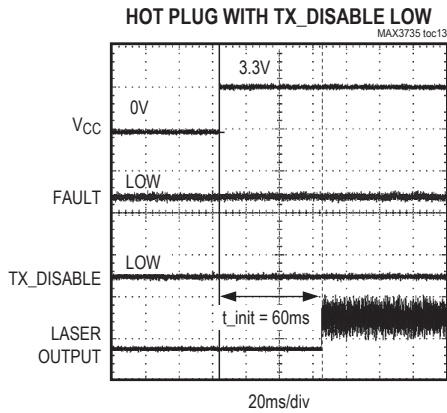
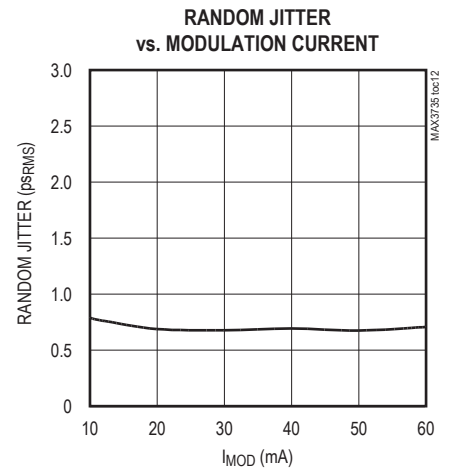
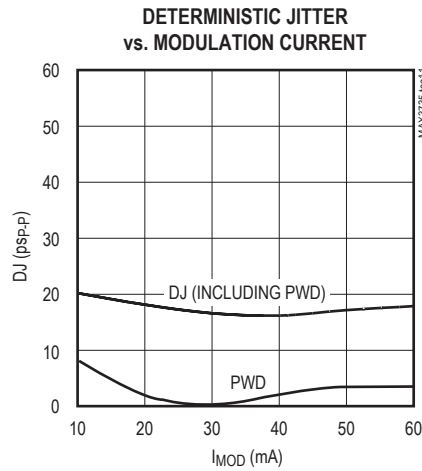
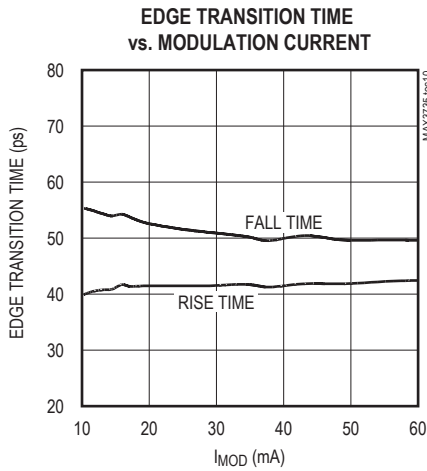
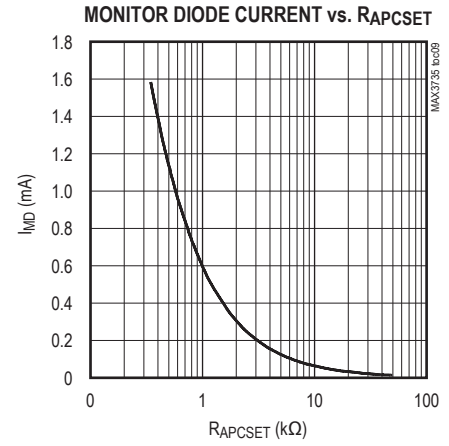
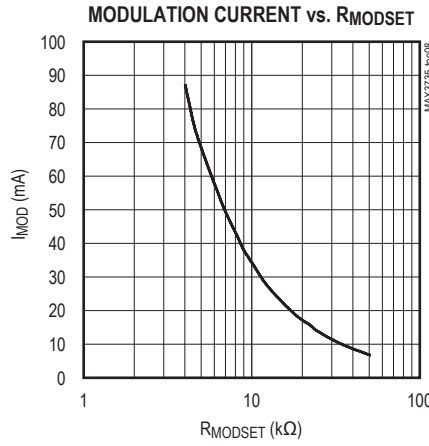
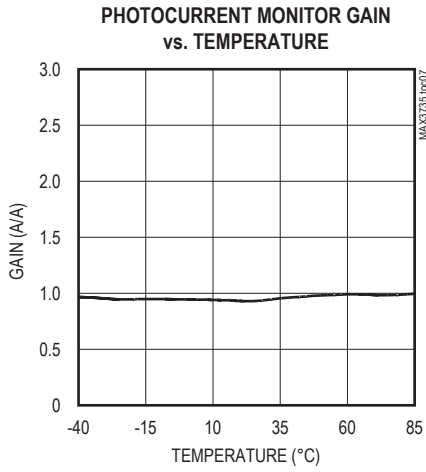

Typical Operating Characteristics (continued)

($V_{CC} = +3.3V$, $C_{APC} = 0.01\mu F$, $I_{BIAS} = 20mA$, and $I_{MOD} = 30mA$, $T_A = +25^\circ C$, unless otherwise noted.)

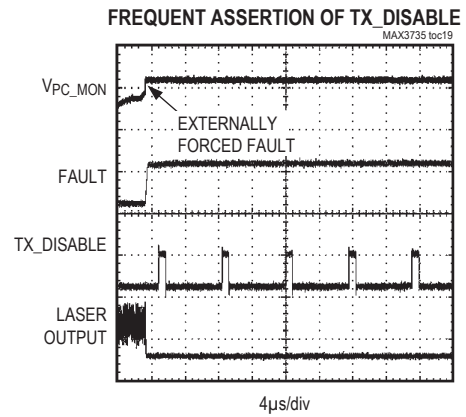
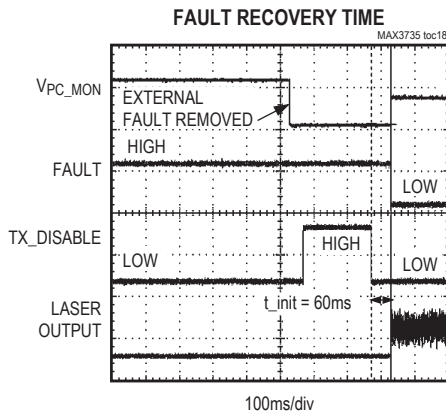
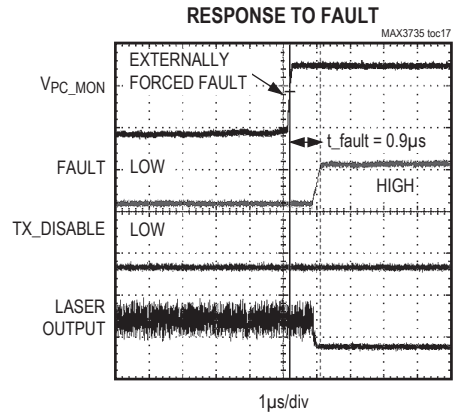
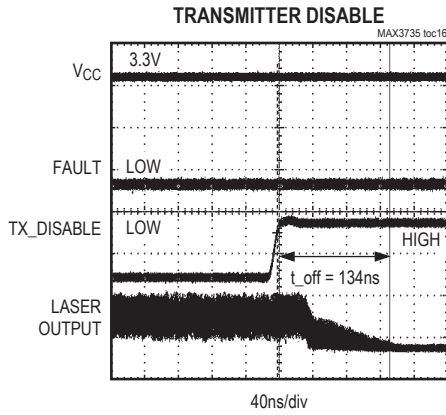

Pin Configuration

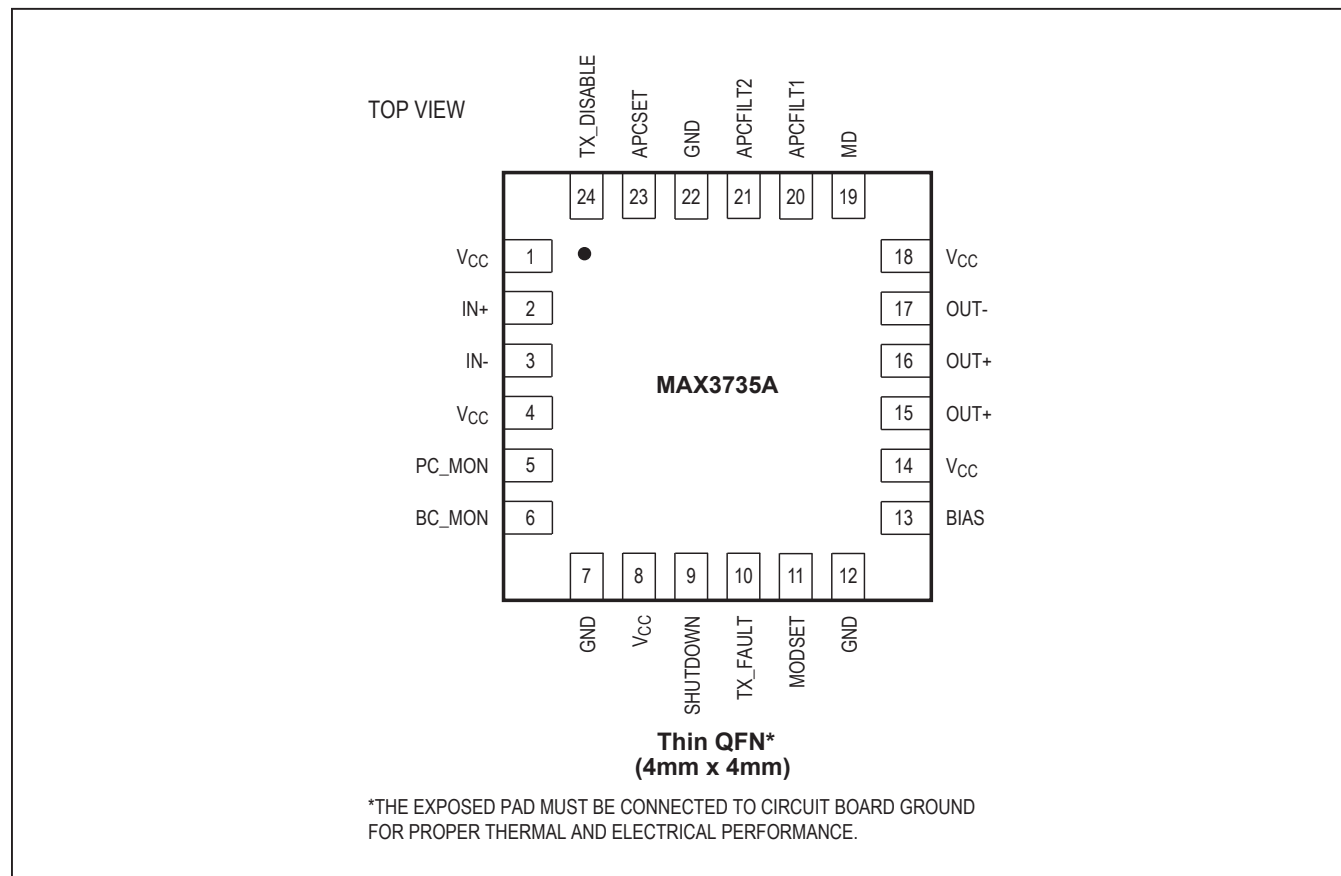

Pin Description

PIN	NAME	FUNCTION
1, 4, 8, 14, 18	V _{CC}	+3.3V Supply Voltage
2	IN+	Noninverted Data Input
3	IN-	Inverted Data Input
5	PC_MON	Photodiode Current Monitor Output. Current out of this pin develops a ground-referenced voltage across an external resistor that is proportional to the monitor diode current.
6	BC_MON	Bias Current Monitor Output. Current out of this pin develops a ground-referenced voltage across an external resistor that is proportional to the bias current.
7, 12, 22	GND	Ground
9	SHUTDOWN	Shutdown Driver Output. Voltage output to control an external transistor for optional shutdown circuitry.
10	TX_FAULT	Open-Collector Transmit Fault Indicator (Table 1).
11	MODSET	A resistor connected from this pad to ground sets the desired modulation current.
13	BIAS	Laser Bias Current Output
15, 16	OUT+	Noninverted Modulation Current Output. Connect pins 15 and 16 externally to minimize parasitic inductance of the package. I _{MOD} flows into this pin when input data is high.
17	OUT-	Inverted Modulation Current Output. I _{MOD} flows into this pin when input data is low.
19	MD	Monitor Diode Input. Connect this pin to the anode of a monitor photodiode. A capacitor to ground is required to filter the high-speed AC monitor photocurrent.
20	APCFILT1	Connect a capacitor (C _{APC}) between pin 20 (APCFILT1) and pin 21 (APCFILT2) to set the dominant pole of the APC feedback loop.
21	APCFILT2	See APCFILT1
23	APCSET	A resistor connected from this pin to ground sets the desired average optical power.
24	TX_DISABLE	Transmitter Disable, TTL. Laser output is disabled when TX_DISABLE is asserted high or left unconnected. The laser output is enabled when this pin is asserted low.
EP	Exposed Pad	Ground. Must be soldered to the circuit board ground for proper thermal and electrical performance (see the Exposed-Pad Package section).

Detailed Description

The MAX3735A laser driver consists of three parts: a high-speed modulation driver, a laser-biasing block with automatic power control (APC), and safety circuitry ([Functional Diagram](#)). The circuit design is optimized for high-speed and low-voltage (+3.3V) operation.

High-Speed Modulation Driver

The output stage is composed of a high-speed differential pair and a programmable modulation current source. The MAX3735A is optimized for driving a 15Ω load; the minimum instantaneous voltage required at OUT+ is 0.6V. Modulation current swings up to 60mA are possible when the laser diode is DC-coupled to the driver and up to 85mA when the laser diode is AC-coupled to the driver.

To interface with the laser diode, a damping resistor (R_D) is required for impedance matching. The combined resistance of the series damping resistor and the equivalent series resistance of the laser diode should equal 15Ω. To reduce optical output aberrations and duty-cycle distortion caused by laser diode parasitic inductance, an RC shunt network might be necessary. Refer to [Maxim Application Note HFAN 02.0: Interfacing Maxim's Laser Drivers to Laser Diodes](#) for more information.

At data rates of 2.7Gbps, any capacitive load at the cathode of a laser diode degrades optical output performance. Because the BIAS output is directly connected to the laser cathode, minimize the parasitic capacitance associated with the pin by using an inductor to isolate the BIAS pin parasitics from the laser cathode.

Functional Diagram

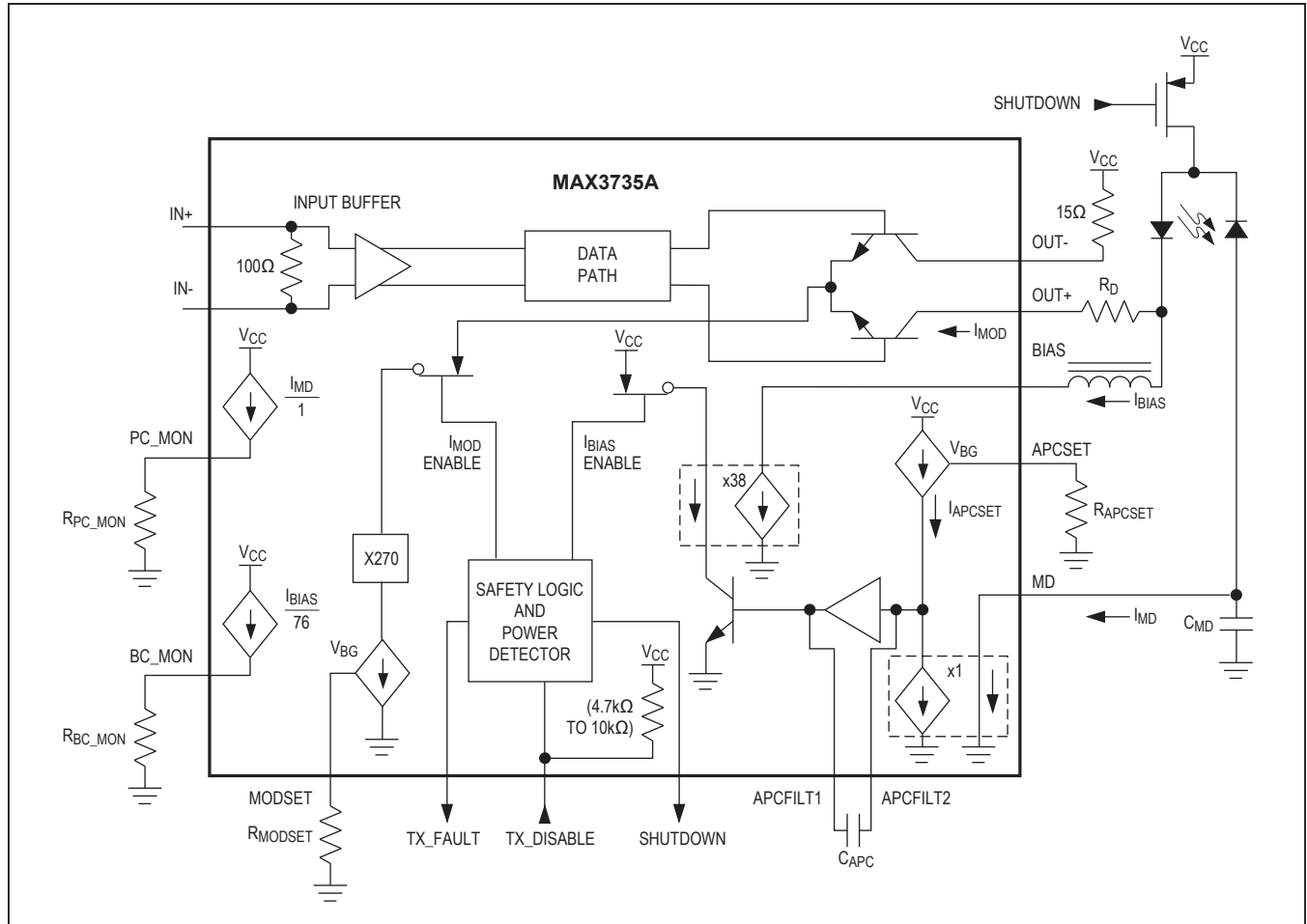

Laser-Biasing and APC

To maintain constant average optical power, the MAX3735A incorporates an APC loop to compensate for the changes in laser threshold current over temperature and lifetime. A back-facet photodiode mounted in the laser package is used to convert the optical power into a photocurrent. The APC loop adjusts the laser bias current so that the monitor current is matched to a reference current set by RAPCSET. The time constant of the APC loop is determined by an external capacitor (CAPC). For possible CAPC values, see the [Applications Information](#) section.

Safety Circuitry

The safety circuitry contains an input disable (TX_DISABLE), a latched fault output (TX_FAULT), and fault detectors (Figure 4). This circuitry monitors the operation of the laser driver and forces a shutdown if a fault is detected (Table 1). A single-point fault can be a short to VCC or GND. See Table 2 to view the circuit response to

various single-point failures. The transmit fault condition is latched until reset by a toggle of TX_DISABLE or VCC. The laser driver offers redundant laser diode shutdown through the optional shutdown circuitry (see the *Typical Applications Circuit*). The TX_FAULT pin should be pulled high with a 4.7kΩ to 10kΩ resistor to VCC as required by the SFP MSA.

Safety Circuitry Current Monitors

The MAX3735A features monitors (BC_MON, PC_MON) for bias current (IBIAS) and photo current (IMD). The monitors are realized by mirroring a fraction of the currents and developing voltages across external resistors connected to ground. Voltages greater than 1.38V at PC_MON or BC_MON result in a fault state. For example, connecting a 100Ω resistor to ground on each monitor output gives the following relationships:

$$V_{BC_MON} = (I_{BIAS} / 76) \times 100\Omega$$

$$V_{PC_MON} = I_{IMD} \times 100\Omega$$

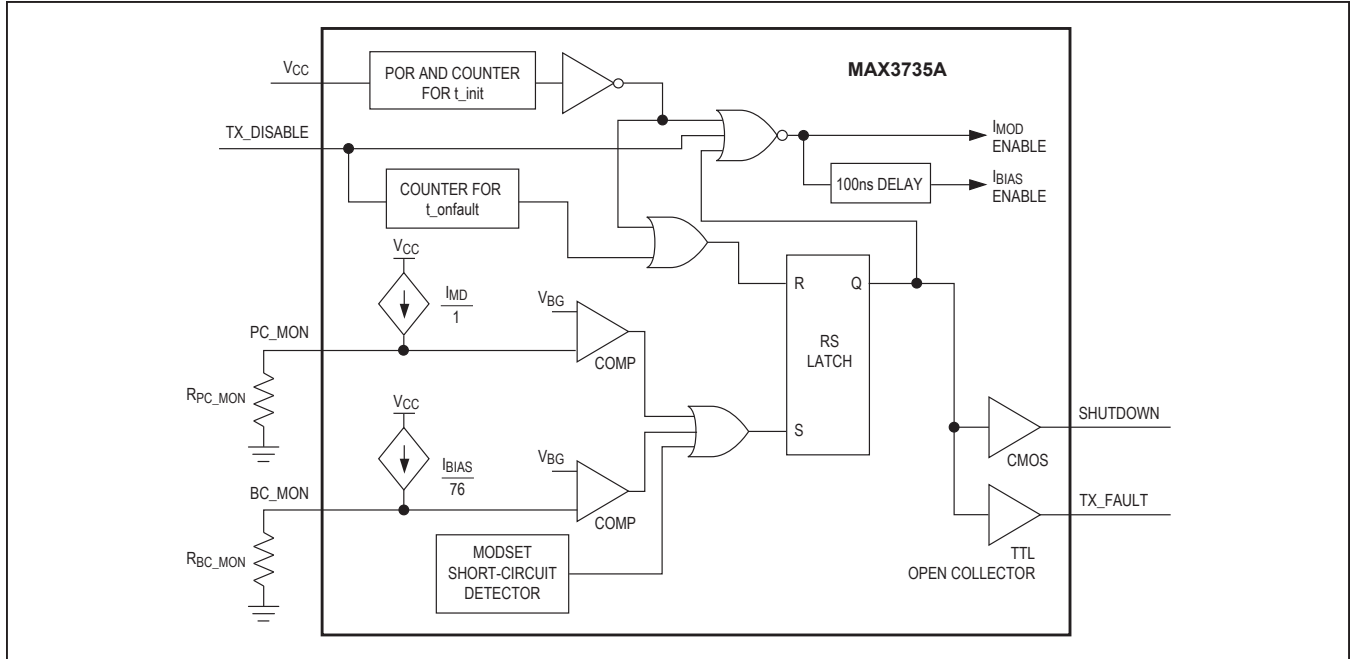

Figure 4. Safety Circuitry

Table 1. Typical Fault Conditions

1.	If any of the I/O pins is shorted to GND or VCC (single-point failure, see Table 2), and the bias current or the photocurrent exceed the programmed threshold.
2.	End-of-life (EOL) condition of the laser diode. The bias current and/or the photocurrent exceed the programmed threshold.
3.	Laser cathode is grounded and the photocurrent exceeds the programmed thresholds.
4.	No feedback for the APC loop (broken interconnection, defective monitor photodiode), and the bias current exceeds the programmed threshold.

Design Procedure

When designing a laser transmitter, the optical output usually is expressed in terms of average power and extinction ratio. Table 3 shows relationships helpful in converting between the optical average power and the modulation current. These relationships are valid if the mark density and duty cycle of the optical waveform are 50%.

Programming the Modulation Current

For a given laser power (P_{AVG}), slope efficiency (η), and extinction ratio (r_e), the modulation current can be calculated using Table 3. See the Modulation Current vs. R_{MODSET} graph in the Typical Operating Characteristics section, and select the value of R_{MODSET} that corresponds to the required current at +25°C.

Programming the APC Loop

Program the average optical power by adjusting $-R_{APCSET}$. To select the resistance, determine the desired monitor current to be maintained over temperature and lifetime. See the Monitor Diode Current vs. R_{APCSET} graph in the Typical Operating Characteristics section, and select the value of R_{APCSET} that corresponds to the required current.

Interfacing with Laser Diodes

To minimize optical output aberrations caused by signal reflections at the electrical interface to the laser diode, a series-damping resistor (R_D) is required (see the Functional Diagram). Additionally, the MAX3735A outputs are optimized for a 15Ω load. Therefore, the series combination of R_D and R_L , where R_L represents the laser-diode resistance, should equal 15Ω. Typical values for R_D are 8Ω to 13Ω. For best performance, place a bypass capacitor (0.01μF typ) as close as possible to the anode of the laser diode. An RC shunt network between the laser cathode and ground minimizes optical output aberrations. Starting values for most coaxial lasers are $R_{COMP} = 50\Omega$ in series with $C_{COMP} = 8pF$. Adjust these values experimentally until the optical output waveform is optimized. Refer to [Maxim Application Note HFAN 02.0: Interfacing Maxim’s Laser Drivers to Laser Diodes](#) for more information.

Table 2. Circuit Responses to Various Single-Point Faults

PIN NAME	CIRCUIT RESPONSE TO OVERVOLTAGE OR SHORT TO V _{CC}	CIRCUIT RESPONSE TO UNDERVOLTAGE OR SHORT TO GROUND
TX_FAULT	Does not affect laser power.	Does not affect laser power.
TX_DISABLE	Modulation and bias currents are disabled.	Normal condition for circuit operation.
IN+	The optical average power increases and a fault occurs if V _{PC_MON} exceeds the threshold. The APC loop responds by decreasing the bias current.	The optical average power decreases and the APC loop responds by increasing the bias current. A fault state occurs if V _{BC_MON} exceeds the threshold voltage.
IN-	The optical average power decreases and the APC loop responds by increasing the bias current. A fault state occurs if V _{BC_MON} exceeds the threshold voltage.	The optical average power increases and a fault occurs if V _{PC_MON} exceeds the threshold. The APC loop responds by decreasing the bias current.
MD	Disables bias current. A fault state occurs.	The APC circuit responds by increasing bias current until a fault is detected, then a fault state* occurs.
SHUTDOWN	Does not affect laser power. If the shutdown circuitry is used, laser current is disabled and a fault state* occurs.	Does not affect laser power.
BIAS	In this condition, laser forward voltage is 0V and no light is emitted.	Fault state* occurs. If the shutdown circuitry is used, the laser current is disabled.
OUT+	The APC circuit responds by increasing the bias current until a fault is detected, then a fault state* occurs.	Fault state* occurs. If the shutdown circuitry is used, laser current is disabled.
OUT-	Does not affect laser power.	Does not affect laser power.
PC_MON	Fault state* occurs.	Does not affect laser power.
BC_MON	Fault state* occurs.	Does not affect laser power.
APCFILT1	IBIAS increases until V _{BC_MON} exceeds the threshold voltage.	IBIAS increases until V _{BC_MON} exceeds the threshold voltage.
APCFILT2	IBIAS increases until V _{BC_MON} exceeds the threshold voltage.	IBIAS increases until V _{BC_MON} exceeds the threshold voltage.
MODSET	Does not affect laser power.	Fault state* occurs.
APCSET	Does not affect laser power.	Fault state* occurs.

*A fault state asserts the TX_FAULT pin, disables the modulation and bias currents, and asserts the SHUTDOWN pin.

Table 3. Optical Power Definitions

PARAMETER	SYMBOL	RELATION
Average Power	P _{AVG}	$P_{AVG} = (P_0 + P_1) / 2$
Extinction Ratio	r _e	$r_e = P_1 / P_0$
Optical Power High	P ₁	$P_1 = 2P_{AVG} \times r_e / (r_e + 1)$
Optical Power Low	P ₀	$P_0 = 2P_{AVG} / (r_e + 1)$
Optical Amplitude	P _{P-P}	$P_{P-P} = P_1 - P_0$
Laser Slope Efficiency	η	$\eta = P_{P-P} / I_{MOD}$
Modulation Current	I _{MOD}	$I_{MOD} = P_{P-P} / \eta$

Pattern-Dependent Jitter

To minimize the pattern-dependent jitter associated with the APC loop time constant, and to guarantee loop stability, connect a capacitor between APCFILT1 and APCFILT2 (see the [Applications Information](#) section for more information about choosing C_{APC} values). A capacitor attached to the photodiode anode (C_{MD}) is also recommended to filter transient currents that originate from the photodiode. To maintain stability and proper phase margin associated with the two poles created by C_{APC} and C_{MD}, C_{APC} should be 4x to 20x greater than C_{MD}.

Input Termination Requirements

The MAX3735A data inputs are SFP MSA compliant. On-chip 100Ω differential input impedance is provided for optimal termination (Figure 5). Because of the on-chip biasing network, the inputs self-bias to the proper operating point to accommodate AC-coupling.

Optional Shutdown Output Circuitry

The SHUTDOWN control output features extended eye safety when the laser cathode is grounded. An external transistor is required to implement this circuit (see the Functional Diagram). In the event of a fault, SHUTDOWN asserts high, placing the optional shutdown transistor in cutoff mode and thereby shutting off the laser current.

Applications Information

An example of how to set up the MAX3735A follows:

Select a communications-grade laser for 2.488Gbps. Assume that the laser output average power is P_{AVG} = 0dBm, the operating temperature is -40°C to +85°C, minimum extinction ratio is 6.6 (8.2dB), and the laser diode has the following characteristics:

- Wavelength: λ = 1.3μm
- Threshold current: I_{TH} = 22mA at +25°C
- Threshold temperature coefficient: β_{TH} = 1.3% / °C
- Laser-to-monitor transfer: ρ_{MON} = 0.2A/W
- Laser slope efficiency: η = 0.05mW/mA at +25°C

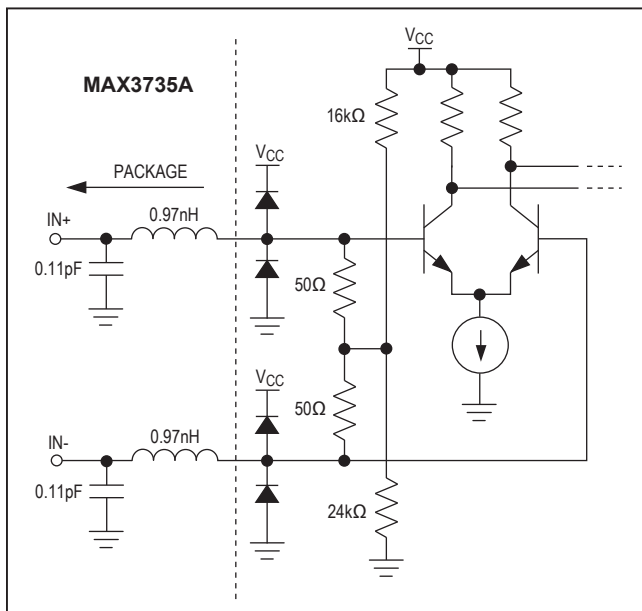

Figure 5. Simplified Input Structure

Determine R_{APCSET}

The desired monitor diode current is estimated by I_{MD} = P_{AVG} × ρ_{MON} = 200μA. The Monitor Diode vs. R_{APCSET} graph in the Typical Operating Characteristics section shows that R_{APCSET} should be 3kΩ. The value can also be estimated using the equation below:

$$I_{MD} = 1.23 / (2 \times R_{APCSET})$$

Determine R_{MODSET}

To achieve a minimum extinction ratio (r_e) of 6.6 over temperature and lifetime, calculate the required extinction ratio at +25°C. Assuming the results of the calculation are r_e = 20 at +25°C, the peak-to-peak optical power P_{P-P} = 1.81mW, according to Table 3. The required modulation current is 1.81mW / (0.05mW/mA) = 36.2mA. The Modulation Current vs. R_{MODSET} graph in the Typical Operating Characteristics section shows that R_{MODSET} should be 9.5kΩ. The value can also be estimated using the equation below:

$$I_{MOD} = 1.23 / (0.0037 \times R_{MODSET})$$

Determine C_{APC}

In order to meet SFP timing requirements and minimize pattern-dependent jitter, the C_{APC} capacitor value is determined by the laser-to-monitor transfer and other variables. The following equations and Table 4 can be used to choose the C_{APC} values for the MAX3735A. The equations and Table 4 assume a DC-coupled laser. Refer to Maxim Application Note HFDN 23.0: Choosing the

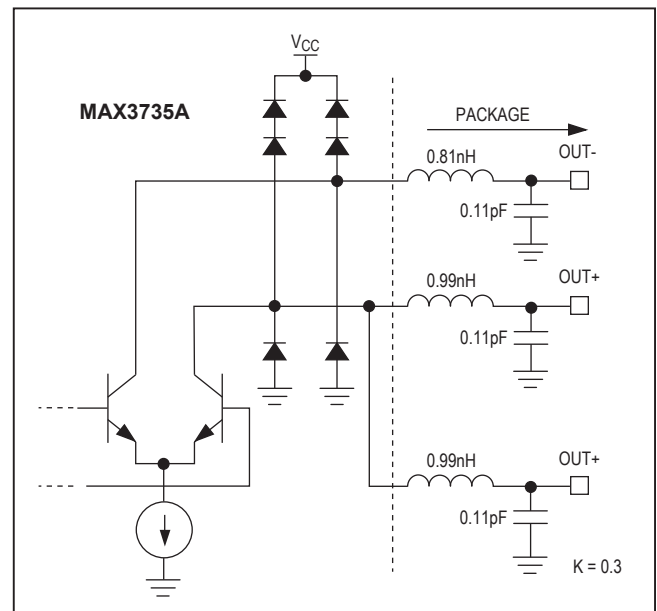

Figure 6. Simplified Output Structure

APC Loop Capacitors Used with MAX3735/MAX3735A SFP Module Designs for more information on choosing C_{APC} for DC- and AC-coupled laser interfaces.

Use [Table 4](#) to choose the C_{APC} capacitor value. C_{APC} should be chosen according to the highest gain of the lasers (generally at cold temperature). C_{APC} selection assumes a 34% reduction in the gain of the lasers at +85°C from the cold (-40°C) values.

Table 4. C_{APC} Selection

LASER GAIN (A/A)	C_{APC} (μF)
0.005	0.039
0.007	0.047
0.010	0.068
0.020	0.100
0.030	0.120
0.040	0.120

where laser Gain = $I_{MD}/(I_{BIAS} - I_{TH} + 0.5 \times I_{MOD})$ for DC-coupled lasers. C_{MD} can then be chosen as approximately 4x to 20x smaller than C_{APC} .

Using the MAX3735A with Digital Potentiometers

For more information on using the MAX3735A with the Dallas DS1858/DS1859 SFP controller, refer to [Maxim Application Note HFAN 2.3.3: Optimizing the Resolution of Laser Driver Setting Using Linear Digital Potentiometers](#) for more information.

Modulation Currents Exceeding 60mA

For applications requiring a modulation current greater than 60mA, headroom is insufficient for proper operation of the laser driver if the laser is DC-coupled. To avoid this problem, the MAX3735A's modulation output can be AC-coupled to the cathode of a laser diode. An external pullup inductor is necessary to DC-bias the modulation output at V_{CC} . Such a configuration isolates laser forward voltage from the output circuitry and allows the output at OUT+ to swing above and below the supply voltage (V_{CC}).

When AC-coupled, the MAX3735A modulation current can be programmed from 10mA to 85mA. Refer to [Maxim Application Note HFAN 02.0: Interfacing Maxim's Laser Drivers to Laser Diodes](#) for more information on ACcoupling laser drivers to laser diodes.

Interface Models

[Figure 5](#) and [6](#) show simplified input and output circuits for the MAX3735A laser driver.

Layout Considerations

To minimize inductance, keep the connections between the MAX3735A output pins and laser diode as close as possible. Optimize the laser diode performance by placing a bypass capacitor as close as possible to the laser anode. Use good high-frequency layout techniques and multiple-layer boards with uninterrupted ground planes to minimize EMI and crosstalk.

Exposed-Pad Package

The exposed pad on the 24-pin QFN provides a very low thermal resistance path for heat removal from the IC. The pad is also electrical ground on the MAX3735A and must be soldered to the circuit board ground for proper thermal and electrical performance. Refer to [Maxim Application Note HFAN-08.1: Thermal Considerations for QFN and Other Exposed-Pad Packages](#) for additional information.

Laser Safety and IEC 825

Using the MAX3735A laser driver alone does not ensure that a transmitter design is compliant with IEC 825. The entire transmitter circuit and component selections must be considered. Each user must determine the level of fault tolerance required by the application, recognizing that Maxim products are neither designed nor authorized for use as components in systems intended for surgical implant into the body, for applications intended to support or sustain life, or for any other application in which the failure of a Maxim product could create a situation where personal injury or death may occur.

Ordering Information

PART	TEMP RANGE	PIN-PACKAGE
MAX3735AETG	-40°C to +85°C	24 Thin QFN-EP*
MAX3735AETG+	-40°C to +85°C	24 Thin QFN-EP*

*EP = Exposed pad.

+Denotes lead-free package.

Chip Information

TRANSISTOR COUNT: 1558

SUBSTRATE CONNECTED TO GND

PROCESS: SiGe Bipolar