

Click [here](#) to ask about the production status of specific part numbers.

## MAX49140

## 30ns, Low-Power, 3V/5V, Rail-to-Rail Single-Supply Comparator

### General Description

The MAX49140 is a single high-speed comparator optimized for systems powered from a 3V or 5V supply. The MAX49140 combines high speed, low power, and rail-to-rail inputs. Propagation delay is 30ns, while supply current is only 100 $\mu$ A (typ).

The input common-mode range of the device extends up to both power-supply rails. The output pulls to within 0.3V of either supply rail without external pullup circuitry, making the device ideal for interfacing with both CMOS and TTL logic. All input and output pins can tolerate a continuous short-circuit fault condition to either rail. Internal hysteresis ensures clean output switching, even with slow-moving input signals.

The MAX49140 is offered in tiny, 5-pin SC70 package and is fully specified over -40°C to +125°C automotive temperature range. The device is AEC-Q100 qualified.

### Benefits and Features

- Fast, 30ns Propagation Delay (10mV Overdrive)
- Low-Power 100 $\mu$ A Supply Current ( $V_{DD} = 3V$ )
- Optimized for 3V and 5V Applications
- Rail-to-Rail Input Voltage Range
- Low, 500 $\mu$ V Offset Voltage
- Internal Hysteresis for Clean Switching
- Output Swing 300mV of Power Rails
- CMOS/TTL-Compatible Outputs
- Small SC70 Package
- AEC-Q100 Qualified

Ordering Information appears at end of data sheet.

### Applications

- Car Battery-Powered Systems
- Line Receivers
- Threshold Detectors/Discriminators
- 3V/5V Systems
- Zero-Crossing Detectors
- Sampling Circuits

### Simplified Block Diagram

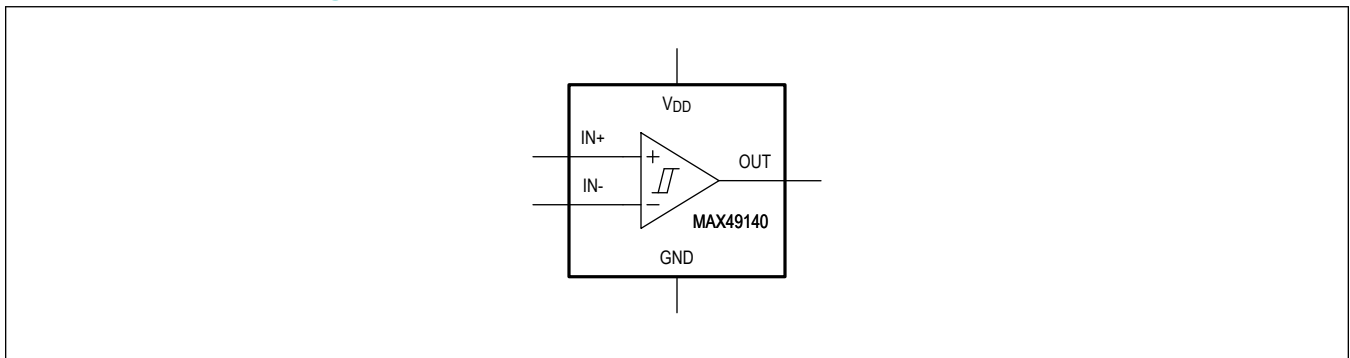

---

**TABLE OF CONTENTS**

---

General Description . . . . .	1
Applications . . . . .	1
Benefits and Features . . . . .	1
Simplified Block Diagram . . . . .	1
Absolute Maximum Ratings . . . . .	4
Package Information . . . . .	4
5 SC70 . . . . .	4
Electrical Characteristics . . . . .	4
Typical Operating Characteristics . . . . .	6
Pin Configuration . . . . .	8
SC70 . . . . .	8
Pin Description . . . . .	8
Detailed Description . . . . .	9
Input Stage Circuitry . . . . .	9
Output Stage Circuitry . . . . .	10
Applications Information . . . . .	11
Circuit Layout and Bypassing . . . . .	11
Typical Applications . . . . .	11
Ordering Information . . . . .	12
Revision History . . . . .	13

---

**LIST OF FIGURES**

---

Figure 1. Input and Output Waveform, Noninverting Input Varied ..... 9

Figure 2. Input Stage Circuitry..... 10

Figure 3. Output Stage Circuitry ..... 10

Figure 4. 3.3V Digitally Controlled Threshold Detector ..... 11

Figure 5. Line Receiver Application..... 11

**Absolute Maximum Ratings**

V <sub>DD</sub> to GND.....	-0.3V to +6V	Operating Temperature Range .....	-40°C to +125°C
IN+, IN- to GND .....	-0.3V to V <sub>DD</sub> + 0.3V	Junction Temperature (T <sub>JMAX</sub> ).....	+150°C
OUT to GND .....	-0.3V to V <sub>DD</sub> + 0.3V	Storage Temperature Range .....	-65°C to +150°C
Current into Input Pins.....	±20mA	Lead Temperature (soldering, 10s).....	+300°C
Input/Output Short-Circuit Duration to V <sub>DD</sub> or GND... Continuous		Soldering Temperature (reflow) .....	+260°C
Continuous Power Dissipation (T <sub>A</sub> = +70°C), 5 Pin SC70 (derate 3.1mW/°C above +70°C), Multilayer Board.....	246.9mW		

Stresses beyond those listed under "Absolute Maximum Ratings" may cause permanent damage to the device. These are stress ratings only, and functional operation of the device at these or any other conditions beyond those indicated in the operational sections of the specifications is not implied. Exposure to absolute maximum rating conditions for extended periods may affect device reliability.

**Package Information**

**5 SC70**

Package Code	X5+1C
Outline Number	<a href="#">21-0076</a>
Land Pattern Number	<a href="#">90-0188</a>
<b>Thermal Resistance, Single-Layer Board:</b>	
Junction-to-Ambient (θ <sub>JA</sub> )	324°C/W
Junction-to-Case Thermal Resistance (θ <sub>JC</sub> )	115°C/W
<b>Thermal Resistance, Four-Layer Board:</b>	
Junction-to-Ambient (θ <sub>JA</sub> )	324°C/W
Junction-to-Case Thermal Resistance (θ <sub>JC</sub> )	115°C/W

For the latest package outline information and land patterns (footprints), go to [www.maximintegrated.com/packages](http://www.maximintegrated.com/packages). Note that a "+", "#", or "-" in the package code indicates RoHS status only. Package drawings may show a different suffix character, but the drawing pertains to the package regardless of RoHS status.

Package thermal resistances were obtained using the method described in JEDEC specification JESD51-7, using a four-layer board. For detailed information on package thermal considerations, refer to [www.maximintegrated.com/thermal-tutorial](http://www.maximintegrated.com/thermal-tutorial).

**Electrical Characteristics**

(V<sub>DD</sub> = 5V, V<sub>CM</sub> = 0.1V, C<sub>L</sub> = 15pF, T<sub>A</sub> = T<sub>MIN</sub> to T<sub>MAX</sub>, unless otherwise noted. Typical values are at T<sub>A</sub> = +25°C.) ([Note 1](#))

PARAMETER	SYMBOL	CONDITIONS	MIN	TYP	MAX	UNITS
V <sub>DD</sub> Supply Voltage	V <sub>DD</sub>	Guaranteed by PSRR specification	2.7		5.5	V
V <sub>DD</sub> Supply Current	I <sub>DD</sub>	V <sub>CM</sub> = 5V, V <sub>DD</sub> = 5V		100	180	µA
			T <sub>A</sub> = -40°C to +85°C		200	
Common-Mode Input Voltage	V <sub>CM</sub>	<a href="#">Note 2</a>	0		V <sub>DD</sub>	V
Input Offset Voltage	V <sub>OS</sub>	<a href="#">Note 3</a>		0.5	5	mV
Input Hysteresis	V <sub>HYS</sub>	<a href="#">Note 4</a>		1.2		mV

**Electrical Characteristics (continued)**(V<sub>DD</sub> = 5V, V<sub>CM</sub> = 0.1V, C<sub>L</sub> = 15pF, T<sub>A</sub> = T<sub>MIN</sub> to T<sub>MAX</sub>, unless otherwise noted. Typical values are at T<sub>A</sub> = +25°C.) ([Note 1](#))

PARAMETER	SYMBOL	CONDITIONS	MIN	TYP	MAX	UNITS
Input Bias Current	I <sub>B</sub>	<a href="#">Note 5</a>	T <sub>A</sub> = +25°C	200	500	nA
			T <sub>A</sub> = -40°C to +125°C		900	
Input Offset Current	I <sub>OS</sub>	T <sub>A</sub> = +25°C		20	50	nA
		T <sub>A</sub> = -40°C to +125°C			100	
Common-Mode Rejection Ratio	CMRR	<a href="#">Note 6</a>		50	500	μV/V
Power-Supply Rejection Ratio	PSRR	2.7V ≤ V <sub>DD</sub> ≤ 5.5V		100	450	μV/V
Output-High Voltage	V <sub>OH</sub>	I <sub>SOURCE</sub> = 4mA	V <sub>DD</sub> - 0.3			V
Output-Low Voltage	V <sub>OL</sub>	I <sub>SINK</sub> = 4mA			0.3	V
Propagation Delay	t <sub>PD+</sub> , t <sub>PD-</sub>	V <sub>DD</sub> = 3V, V <sub>OD</sub> = 10mV, V <sub>CM</sub> = 0.1V		30		ns
Propagation Delay Skew		V <sub>OD</sub> = 10mV ( <a href="#">Note 7</a> )		1		ns

**Note 1:** All specifications are 100% production tested at T<sub>A</sub> = +25°C. Specification limits over temperature (T<sub>A</sub> = T<sub>MIN</sub> to T<sub>MAX</sub>) are guaranteed by design, not production tested.

**Note 2:** Inferred from CMRR test. Note also that either or both inputs can be driven to the absolute maximum limit (0.3V beyond either supply rail) without damage or false output inversion.

**Note 3:** V<sub>OS</sub> is defined as the center of the input-referred hysteresis zone. See [Figure 1](#).

**Note 4:** The input-referred trip points are the extremities of the differential input voltage required to make the comparator output change state. The difference between the upper and lower trip points is equal to the width of the input-referred hysteresis zone. See [Figure 1](#).

**Note 5:** The polarity of I<sub>B</sub> reverses direction as V<sub>CM</sub> approaches either supply rail.

**Note 6:** Specified over the full common-mode voltage range (V<sub>CM</sub>).

**Note 7:** Specified as the difference between t<sub>PD+</sub> and t<sub>PD-</sub>.

Typical Operating Characteristics

( $V_{DD} = 3.0V$ ,  $V_{CM} = 0.1V$ ,  $C_L = 15pF$ ,  $V_{OD} = 10mV$ ,  $T_A = +25^\circ C$ , unless otherwise noted.)

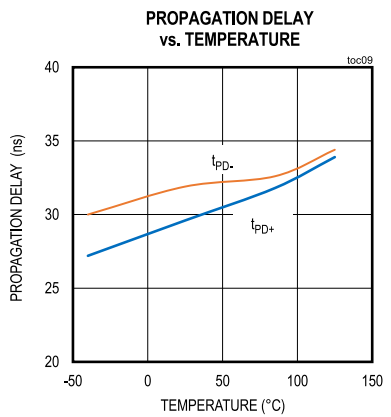
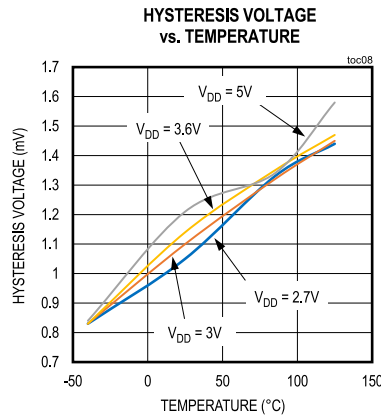
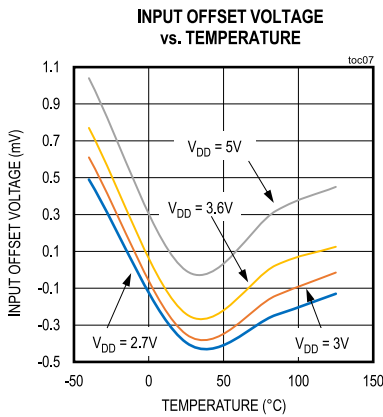
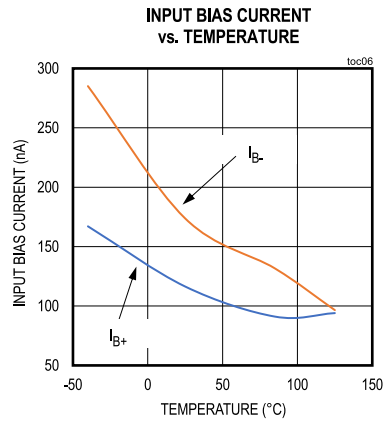
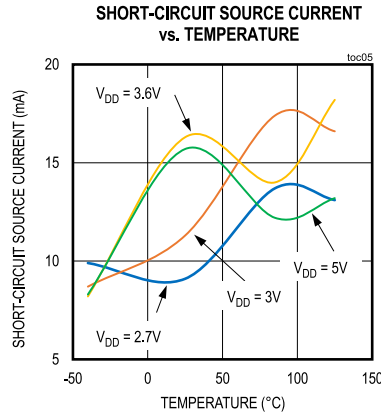
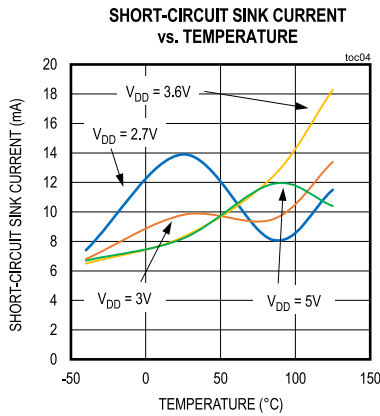
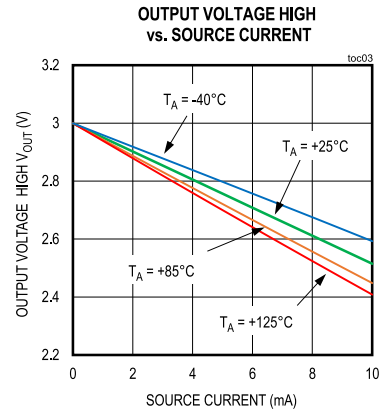
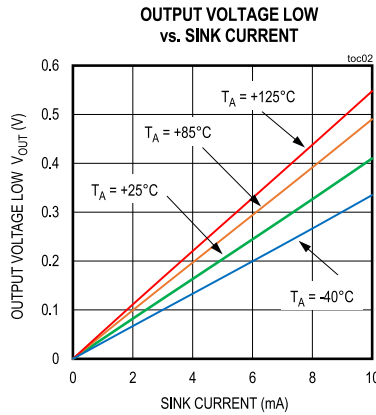
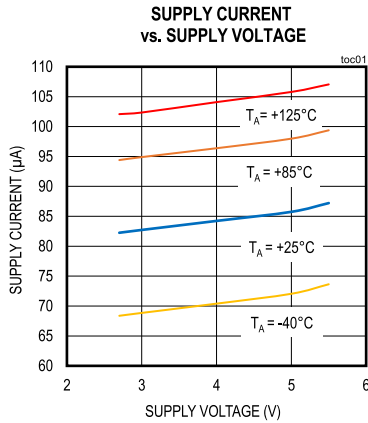

Typical Operating Characteristics (continued)

( $V_{DD} = 3.0V$ ,  $V_{CM} = 0.1V$ ,  $C_L = 15pF$ ,  $V_{OD} = 10mV$ ,  $T_A = +25^\circ C$ , unless otherwise noted.)

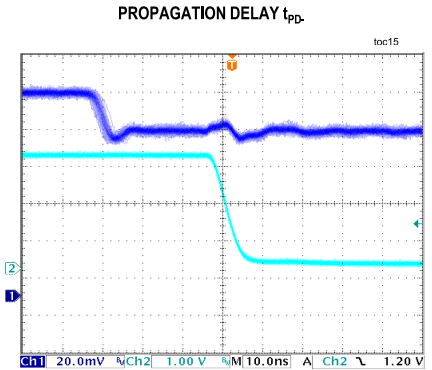
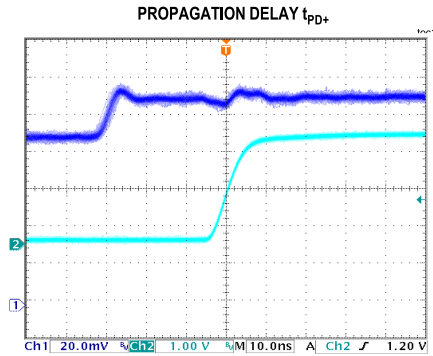
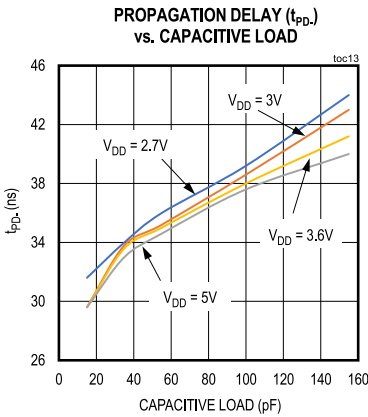
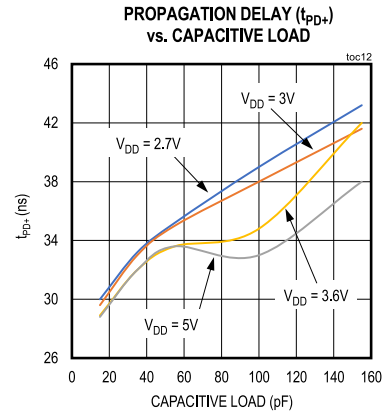
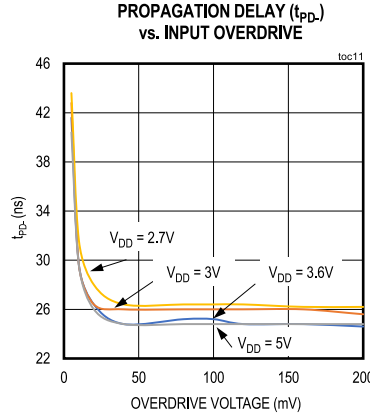
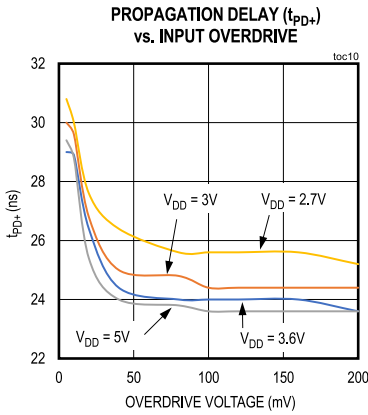

SINUSOID RESPONSE AT 4MHz

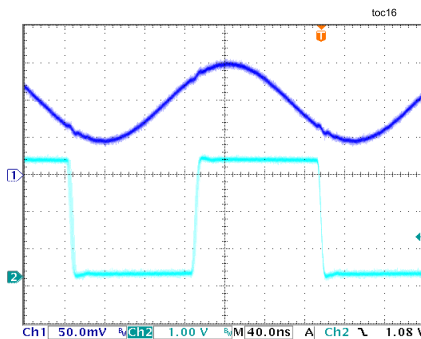

## Pin Configuration

### SC70

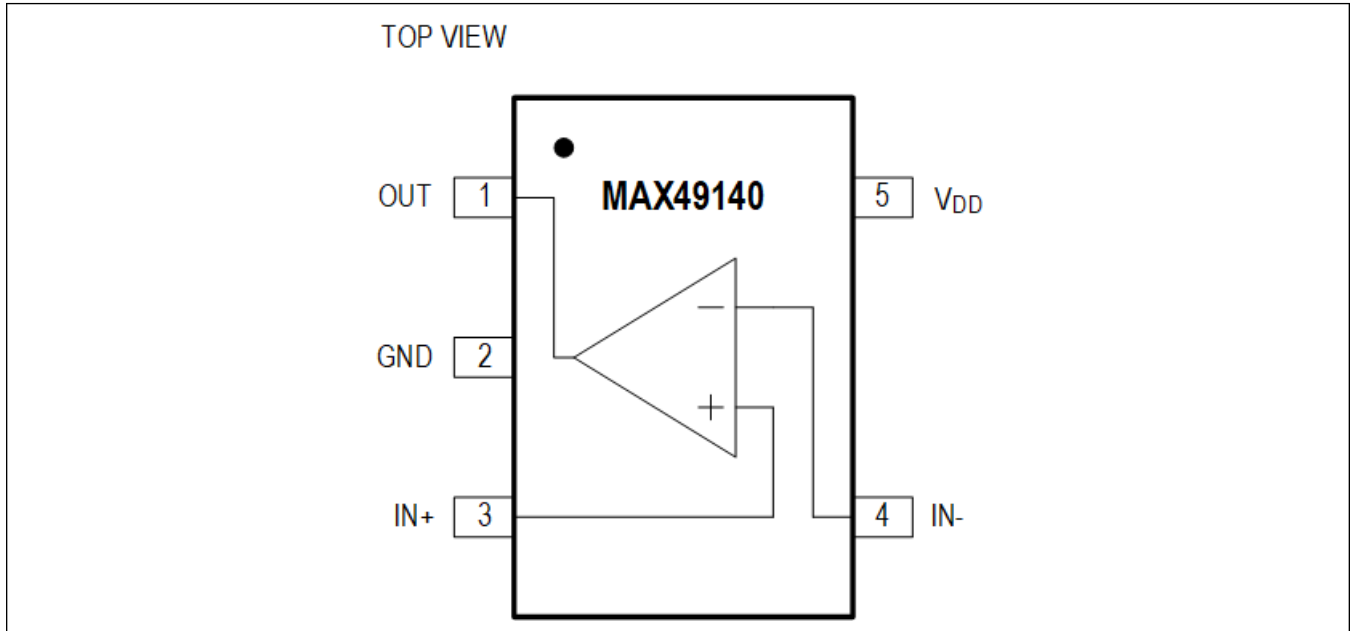

## Pin Description

PIN	NAME	FUNCTION
1	OUT	Comparator Output
2	GND	Ground
3	IN+	Noninverting Input
4	IN-	Inverting Input
5	V <sub>DD</sub>	Positive Supply



## Detailed Description

The MAX49140 single-supply comparator features internal hysteresis, high speed, and low power. The output is pulled to within 300mV of either supply rail without external pullup or pulldown circuitry. Rail-to-rail input voltage range and low-voltage, single-supply operation make the device ideal for portable equipment. The devices interface directly to CMOS and TTL logic.

Most high-speed comparators oscillate in the linear region because of noise or undesired parasitic feedback. This tends to occur when the voltage on one input is at or equal to the voltage on the other input. To counter the parasitic effects and noise, the device has an internal hysteresis of 1.2mV.

The hysteresis in a comparator creates two trip points: one for the rising input voltage and one for the falling input voltage (Figure 1). The difference between the trip points is the hysteresis. The average of the trip points is the offset voltage. When the comparator's input voltages are equal, the hysteresis effectively causes one comparator input voltage to move quickly past the other, thus taking the input out of the region where oscillation occurs. Standard comparators require hysteresis to be added with external resistors. The device's fixed internal hysteresis eliminates these resistors. To increase hysteresis and noise margin even more, add positive feedback with two resistors as a voltage-divider from the output to the non-inverting input.

Figure 1 illustrates the case where IN- is fixed and IN+ is varied. If the inputs were reversed, the figure would look the same, except the output would be inverted.

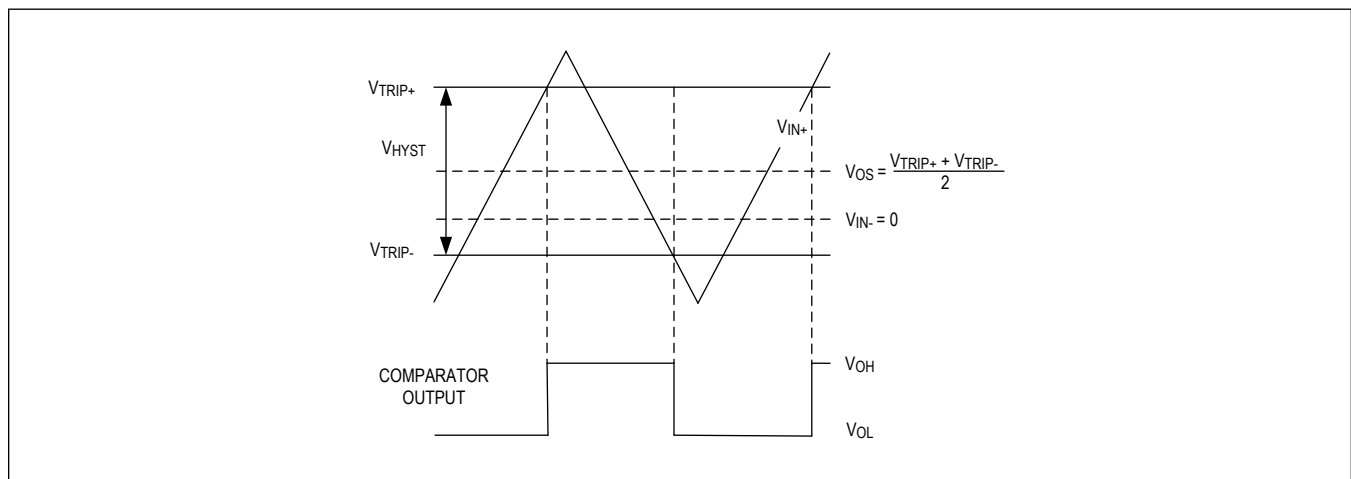

Figure 1. Input and Output Waveform, Noninverting Input Varied

## Input Stage Circuitry

The device includes internal protection circuitry that prevents damage to the precision input stage from large differential input voltages. This protection circuitry consists of two back-to-back diodes between IN+ and IN- as well as two series 1k $\Omega$  resistors (Figure 2). The diodes limit the differential voltage applied to the internal circuitry of the comparator to be no more than  $2V_F$ , where  $V_F$  is the forward voltage drop of the diode (about 0.7V at +25°C).

For a large differential input voltage (exceeding  $2V_F$ ), this protection circuitry increases the input bias current at IN+ (source) and IN- (sink).

$$\text{InputCurrent} = \frac{(I_{N+} - I_{N-}) - 2V_F}{2 \times 1\text{k}\Omega}$$

Input current with large differential input voltages should not be confused with input bias current ( $I_B$ ). As long as the differential input voltage is less than  $2V_F$ , this input current is equal to  $I_B$ . The output is in the correct logic state if one or both inputs are within the common-mode range.

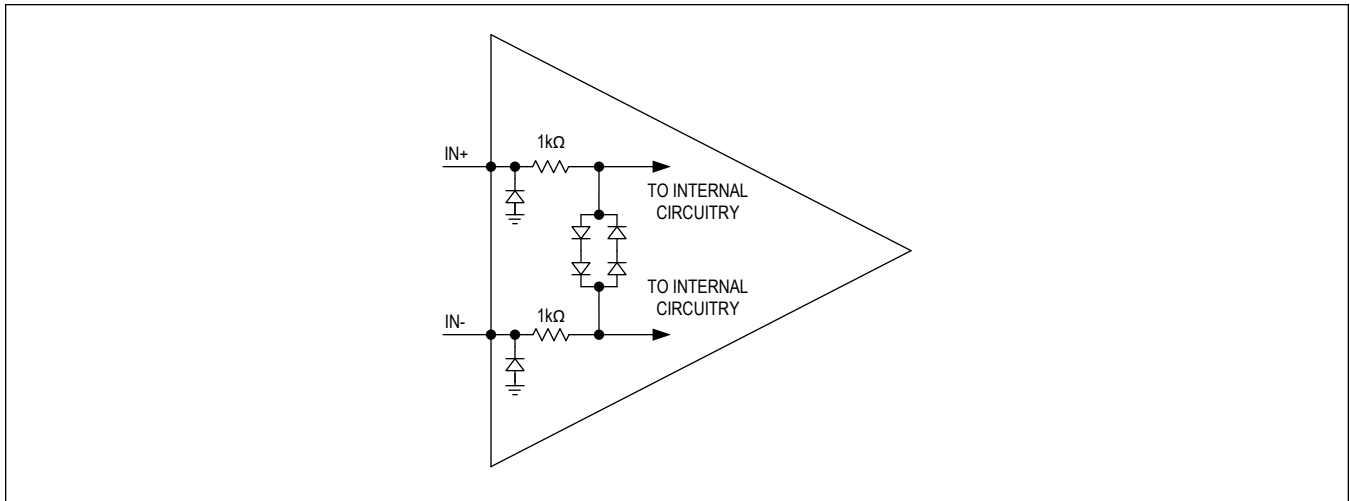

Figure 2. Input Stage Circuitry

**Output Stage Circuitry**

The MAX49140 contains a current-driven output stage as shown in [Figure 3](#). During an output transition,  $I_{SOURCE}$  or  $I_{SINK}$  is pushed or pulled to the output pin. The output source or sink current is high during the transition, creating a rapid slew rate. Once the output voltage reaches  $V_{OH}$  or  $V_{OL}$ , the source or sink current decreases to a small value, capable of maintaining the  $V_{OH}$  or  $V_{OL}$  static condition. This significant decrease in current conserves power after an output transition has occurred.

One consequence of a current-driven output stage is a linear dependence between the slew rate and the load capacitance. A heavy capacitive load will slow down a voltage output transition. This can be useful in noise-sensitive applications where fast edges may cause interference.

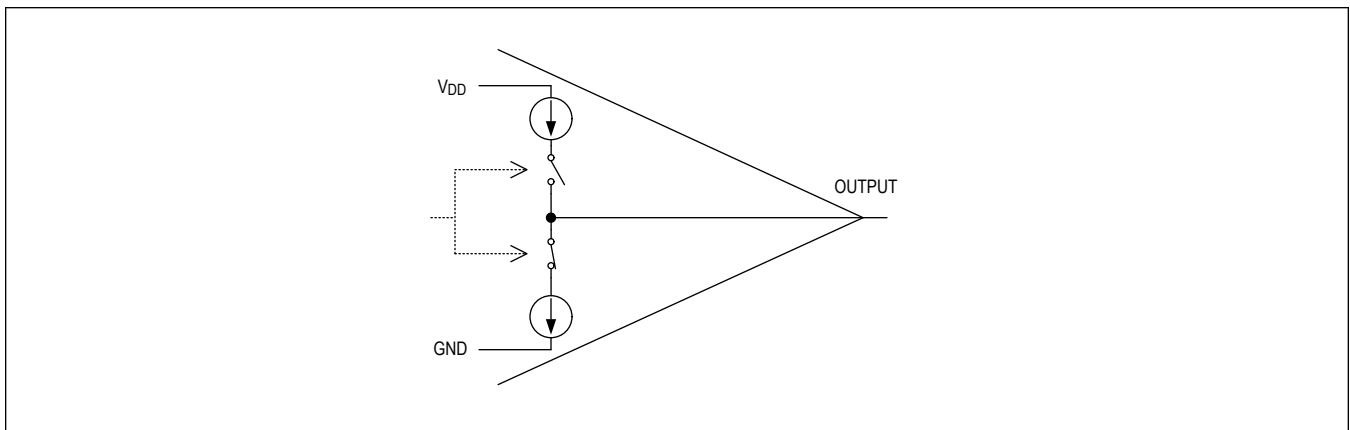

Figure 3. Output Stage Circuitry

## Applications Information

### Circuit Layout and Bypassing

The high-gain bandwidth of the MAX49140 requires design precautions to realize the full high-speed capabilities of this comparator. The recommended precautions are:

- 1) Use a PCB with a good, unbroken, low-inductance ground plane.
- 2) Place a decoupling capacitor (a 0.1 $\mu$ F ceramic capacitor is a good choice) as close to  $V_{DD}$  as possible.
- 3) Pay close attention to the decoupling capacitor's bandwidth, keeping leads short.
- 4) On the inputs and outputs, keep lead lengths short to avoid unwanted parasitic feedback around the comparator.
- 5) Solder the device directly to the PCB instead of using a socket.

### Typical Applications

[Figure 4](#) and [Figure 5](#) show two typical applications.

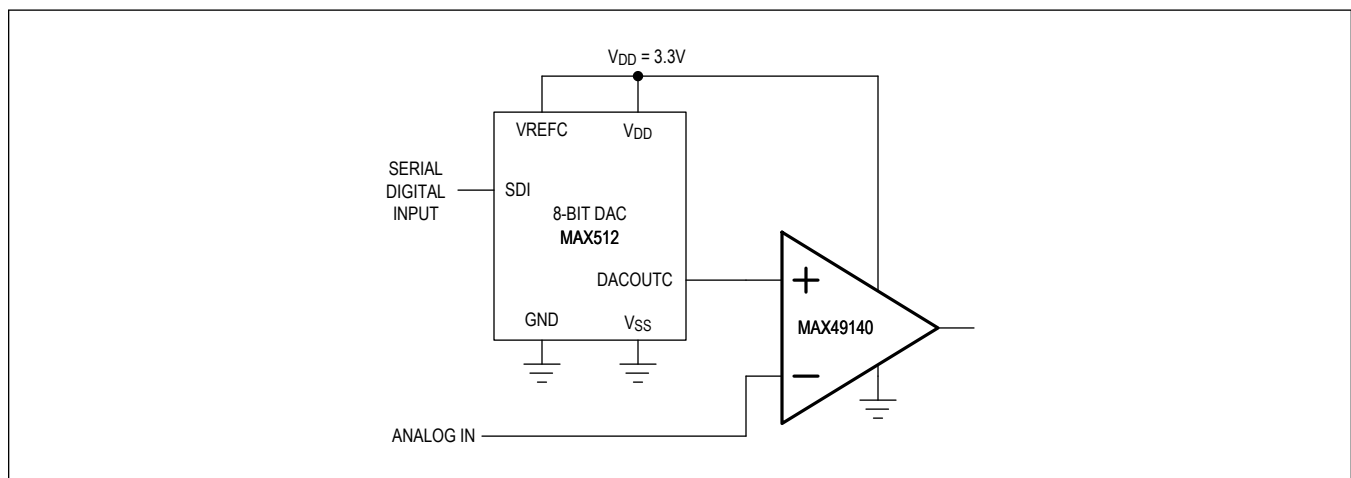

Figure 4. 3.3V Digitally Controlled Threshold Detector

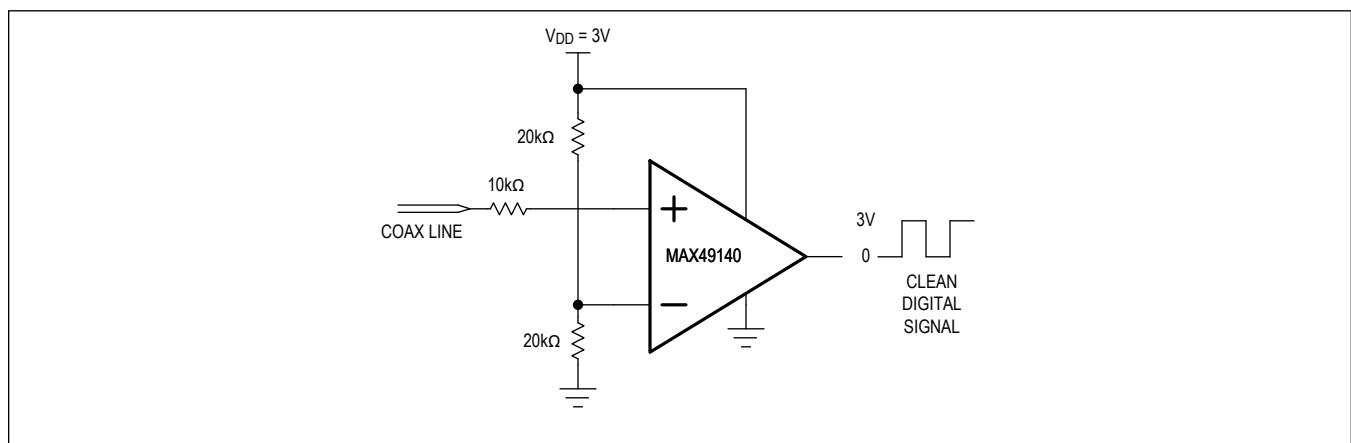

Figure 5. Line Receiver Application

MAX49140

30ns, Low-Power, 3V/5V, Rail-to-Rail Single-Supply Comparator

### Ordering Information

PART NUMBER	TEMP RANGE	PIN-PACKAGE	TOP MARK
MAX49140AXK/V+T	-40°C to +125°C	5 SC70	+AVC

+Denotes a lead(Pb)-free/RoHS-compliant package.

T = Tape and reel.

/V denotes an automotive qualified part.