

MAX5971B Evaluation Kit

Evaluates: MAX5971B

General Description

The MAX5971B evaluation kit (EV kit) is a fully assembled and tested surface-mount PCB featuring an Ethernet single-port power-sourcing equipment (PSE) circuit for -54V supply rail systems. The IEEE® 802.3af/at-compliant MAX5971B PSE controller IC, in a 28-pin TQFN package, features an internal n-channel power MOSFET forming the main PSE circuit on the EV kit. The IC is used in single-port power-over-Ethernet (PoE) applications.

The EV kit provides optical isolation for the IC's I²C-compatible 2-wire interface. The isolated interface can connect to a PC's USB port through an on-board USB interface circuit. The EV kit can be reconfigured for interfacing to a user's stand-alone microcontroller for isolated or nonisolated operation. In stand-alone operation, the user must supply a separate +3.3V power supply capable of supplying 35mA. The EV kit requires a -32V to -60V power supply (-54V supply rail) capable of supplying 1A or more to the EV kit for powering the powered device (PD) through the 10/100/1000BASE-TX Ethernet network port. The EV kit demonstrates PD discovery, classification, current-limit control, and other functions of an IEEE 802.3af/at-compliant PSE.

The IC controls the -54V DC power to the Ethernet network port by sensing current through the port and controlling the IC's internal power MOSFET. Current is fed to a 1Gb x 1Gb MagJack® module Ethernet output port.

The EV kit demonstrates the full functionality of the IC, such as configurable operational modes, port current information through the I²C interface, high-power modes (programmable up to 40W), PD detection (including legacy PD detection), PD classification, overcurrent protection, current foldback, undervoltage/overvoltage protection, and AC-/DC-disconnect monitoring. All these features are configurable on the EV kit, with additional test points for voltage probing and current measurements provided. The EV kit can also be configured for midspan or end-point network operation. The EV kit software is Windows® 2000, Windows XP®, and Windows Vista® compatible, providing a user-friendly interface to demonstrate the IC features while providing access to each register at the bit level. The program is menu driven, offers a graphical user interface (GUI) with control buttons, and includes a macro engine for automated evaluation and testing of the IC at the system level. The program's macro output files can be automatically saved.

Order the EV kit for a complete PC-based evaluation of the IC. To evaluate the MAX5971A IC, order the MAX5971A EV kit.

Features

- ◆ IEEE 802.3af/at-Compliant PSE Circuit
- ◆ Port Current Read-Out Through I²C Interface
- ◆ High-Power Class 5 Mode Configurable Up to 40W
- ◆ -32V to -60V Input Voltage Providing 1A
- ◆ Ethernet Network Ports
 - RJ45 10/100/1000BASE-TX Ethernet Network Data Input Port
 - RJ45 10/100/1000BASE-TX Ethernet Network PSE Output Port
- ◆ Demonstrates MAX5971B Internal Power Switch and Current Sensing
- ◆ Demonstrates Standard and Legacy PD Detection and Classification
- ◆ Configurable for Midspan or End-Point Mode
- ◆ Configurable AC/DC Load-Removal Detection and Disconnect Monitoring
- ◆ Convenient Voltage and Current Test Points
- ◆ Demonstrates IC's Output-Port LED Status Indicators
- ◆ Optically Isolated I²C-Compatible 2-Wire PC Interface
- ◆ Reconfigurable for Stand-Alone Operation or with an External Microcontroller (Requires +3.3V, 35mA Supply)
- ◆ Windows 2000-, Windows XP-, and Windows Vista (32-Bit)-Compatible Software
- ◆ Proven PCB Layout
- ◆ Fully Assembled and Tested

[Ordering Information](#) appears at end of data sheet.

IEEE is a registered service mark of the Institute of Electrical and Electronics Engineers, Inc.

MagJack is a registered trademark of Bel Fuse Inc.

Windows, Windows XP, and Windows Vista are registered trademarks of Microsoft Corp.

MAX5971B Evaluation Kit

Evaluates: MAX5971B

Component List

DESIGNATION	QTY	DESCRIPTION
C1	1	47 μ F \pm 20%, 100V electrolytic capacitor (12.5mm x 13.5mm) Panasonic EEEFK2A470Q
C2	1	1 μ F \pm 10%, 100V X7R ceramic capacitor (1210) AVX 12101C105KAT9A
C3, C5, C7	3	0.1 μ F \pm 10%, 100V X7R ceramic capacitors (0603) Murata GRM188R72A104KA35B
C4	1	0.47 μ F \pm 10%, 100V X7R ceramic capacitor (0805) Murata GRM21BR72A474KA73B
C6, C9, C10	3	0.1 μ F \pm 10%, 16V X7R ceramic capacitors (0603) Murata GRM188R71C104K or TDK C1608X7R1C104K
C8	1	10 μ F \pm 20%, 6.3V X5R ceramic capacitor (0805) Murata GRM21BR60J106M or TDK C2012X5R0J106M
C11	1	1.0 μ F \pm 10%, 6.3V X5R ceramic capacitor (0603) AVX 06036D105KA or Taiyo Yuden JMK107BJ105KA
C12	1	1000pF \pm 10%, 50V X7R ceramic capacitor (0603) Murata GRM188R71H102K
C201, C203–C210, C217, C221	11	0.1 μ F \pm 10%, 16V X7R ceramic capacitors (0603) Murata GRM188R71C104K or TDK C1608X7R1C104K
C202, C213, C215	3	10 μ F \pm 20%, 6.3V X5R ceramic capacitors (0805) Murata GRM21BR60J106M or TDK C2012X5R0J106M
C211, C212	2	10pF \pm 5%, 50V C0G ceramic capacitors (0603) Murata GRM1885C1H100J or TDK C1608C0G1H100J
C214	1	1 μ F \pm 10%, 10V X5R ceramic capacitor (0603) Murata GRM188R61A105K or TDK C1608X5R1A105K

DESIGNATION	QTY	DESCRIPTION
C216	1	2.2 μ F \pm 10%, 6.3V X5R ceramic capacitor (0603) Murata GRM188R60J225K or TDK C1608X5R0J225K
C218, C219	2	22pF \pm 5%, 50V C0G ceramic capacitors (0603) Murata GRM1885C1H220J or TDK C1608C0G1H220J
C220	1	3300pF \pm 10%, 50V X7R ceramic capacitor (0603) Murata GRM188R71H332K or TDK C1608X7R1H332K
D1, D3	2	150mA, 100V small-signal diodes (SOD323) Fairchild 1N4148WS (Top Mark: S1)
D2	1	58V, 600W transient voltage suppressor (SMB) Vishay SMBJ58A (Top Mark: NG—with a single cathode band at one end; band aligns with band on silkscreen)
D4	1	1A, 100V general-purpose diode (SMA) Diodes Inc. S1B
D5	1	6.2A, 60V transient voltage suppressor diode (SMB) Diodes Inc. SMBJ60A-13-F
D6	1	100mA, 30V Schottky diode (SOD323) Diodes Inc. CMDSH-3 (Top Mark: S1)
D201	1	Green LED (0603) Panasonic LNJ314G8TRA
FB201	0	Not installed, ferrite-bead inductor—short (PC trace) (0603)
GND (x2), RTN, VEE	4	Uninsulated banana jacks
J1	1	RJ45 connector module jack (8-8)
J2	1	RJ45 1x1Gb MagJack, 1000 Base-T, 1 x 1 port, voice-over-IP magnetics (700mA DC) Bel Fuse Inc. 0826-1X1T-GH-F

MAX5971B Evaluation Kit

Evaluates: MAX5971B

Component List (continued)

DESIGNATION	QTY	DESCRIPTION
JU1–JU6	6	2-pin headers
JU7	1	5-pin header
JU8	0	Not installed, 8-pin (2 x 4) header
JU9–JU12	0	Not installed, 2-pin headers—short (PC trace)
L1	1	10mH, 17mA inductor Coilcraft DS1608C-106
P201	1	-20V, -2.4A, p-channel MOSFET (3 SuperSOT) Fairchild FDN304P (Top Mark: 304)
R1	1	9.09k Ω \pm 1% 1/2W resistor (2010) Panasonic ERJ-12SF9091U
R2, R14, R18, R19, R20, R22, R23, R24, R26, R28	10	3k Ω \pm 5% resistors (0603)
R3, R10–R13, R15, R16	7	1k Ω \pm 5% resistors (0402)
R4	1	2.2M Ω \pm 5% resistor (0805)
R5, R6	0	Not installed, resistors (1206)
R7, R8	2	0 Ω \pm 5% resistors (1206)
R9	0	Not installed, resistor (0402)
R17, R21, R25, R27	4	180 Ω \pm 5% resistors (0603)
R29	1	5.1k Ω \pm 5% resistor (0603)
R30, R31, R32	0	Not installed, resistors (0805) R30 is open; R31 and R32 are short (PC trace)
R201	1	0 Ω \pm 5% resistor (0603)
R202	1	220 Ω \pm 5% resistor (0603)
R203	1	10k Ω \pm 5% resistor (0603)
R204	1	2.2k Ω \pm 5% resistor (0603)
R205	1	1.5k Ω \pm 5% resistor (0603)
R206, R207	2	27 Ω \pm 5% resistors (0603)
R208	1	1k Ω \pm 5% resistor (0603)
SW1	1	Microminiature pushbutton switch
TP1, TP3–TP10, TP12	10	Miniature PC test points, yellow
TP2	1	Miniature PC test point, red
TP11, TP13	2	Miniature PC test points, black
U1	1	Single-port PSE controller (28 TQFN-EP) Maxim MAX5971BET1+

DESIGNATION	QTY	DESCRIPTION
U2	1	High-voltage linear regulator (6 TDFN-EP) Maxim MAX6765TTSD2+T
U3, U4	2	High-speed, 15Mbps logic gate optocouplers (8 SO) CEL/NEC PS9821-2-A
U5	1	TinyLogic [®] UHS dual buffer with Schmitt trigger inputs (6 SC70) Fairchild NC7WZ17P6X (Top Mark: Z17)
U6	1	TinyLogic UHS dual buffer with open-drain outputs (6 SC70) Fairchild NC7WZ07P6X (Top Mark: Z07)
U201	1	32-bit microcontroller (68 QFN-EP) Maxim MAXQ2000-RAX+
U202	1	93C46-type 2-wire EEPROM (8 SO) Atmel AT93C46EN-SH-B
U203	1	UART-to-USB converter (32 TQFP, 7mm x 7mm) FTDI FT232BL
U204	1	3.3V, 300mA regulator (5 SOT23) Maxim MAX8888EZK33+T (Top Mark: ADQC)
U205	1	2.5V, 120mA regulator (5 SC70) Maxim MAX8511EXK25+T (Top Mark: ADV)
USB	1	USB type-B right-angle female connector
Y201	1	16MHz crystal Hong Kong X'tals SSM1600000E18FAF
Y202	1	6MHz crystal Hong Kong X'tals SSL6000000E18FAF
—	4	Rubber bumpers
—	1	USB-A male to USB-B male cable, 6ft
—	7	Shunts (JU1–JU7)
—	1	PCB: MAX5971B EVALUATION KIT

TinyLogic is a registered trademark of Fairchild Semiconductor.

MAX5971B Evaluation Kit

Evaluates: MAX5971B

Component Suppliers

SUPPLIER	PHONE	WEBSITE
AVX Corporation	843-946-0238	www.avxcorp.com
Bel Fuse Inc.	201-432-0463	www.belfuse.com
CEL/NEC	408588-2247	www.cel.com
Coilcraft, Inc.	847-639-6400	www.coilcraft.com
Diodes Incorporated	805-446-4800	www.diodes.com
Fairchild Semiconductor	888-522-5372	www.fairchildsemi.com
Murata Electronics North America, Inc.	770-436-1300	www.murata-northamerica.com
Panasonic Corp.	800-344-2112	www.panasonic.com
Taiyo Yuden	800-348-2496	www.t-yuden.com
TDK Corp.	847-803-6100	www.component.tdk.com
Vishay	402-563-6866	www.vishay.com

Note: Indicate that you are using the MAX5971B when contacting these component suppliers.

MAX5971B EV Kit Files

FILE	DESCRIPTION
INSTALL.EXE	Installs the EV kit files on your computer
MAX5971B.EXE	Application program
FTD2XX.INF	USB device driver file
POWER_ON.SMB	Bitmap macro routine
TEST#1_MANUAL_MODE.SMB	Bitmap macro routine
TEST#2_AUTO_MODE_DC.SMB	Bitmap macro routine
TEST#3_AUTO_MODE_AC.SMB	Bitmap macro routine
TEST#4_SEMIAUTO_MODE.SMB	Bitmap macro routine
UNINST.INI	Uninstalls the EV kit software
USB_Driver_Help.PDF	USB driver installation help file

Quick Start

Required Equipment:

- MAX5971B EV kit (USB cable included)
- -32V to -60V, 1A capable DC power supply
- User-supplied Windows 2000, Windows XP, or Windows Vista PC with a spare USB port
- USB I/O extension cable, straight-through, male-to-female cable
- Voltmeter for confirming output voltage

Warning: The GND banana jack is more positive than the VEE or RTN banana jack. **Use an isolated oscilloscope for probing with respect to VEE or RTN.**

Note: In the following sections, software-related items are identified by bolding. Text in **bold** refers to items directly from the EV kit software. Text in **bold and underlined** refers to items from the Windows operating system.

Hardware Connections

The EV kit is fully assembled and tested. Follow the steps below to verify board operation. **Caution: Do not turn on the power supply until all connections are completed.**

- 1) Visit www.maxim-ic.com/evkitsoftware to download the latest version of the EV kit software, 5971BRXX.ZIP. Save the EV kit software to a temporary folder and uncompress the ZIP file.
- 2) Install the EV kit software on your computer by running the INSTALL.EXE program inside the temporary folder. The program files are copied and icons are created in the Windows **Start | Programs** menu.
- 3) Verify that a shunt is not installed on jumpers JU1 (ILIM1, Class 0–Class 4), JU2 (ILIM2, Class 0–Class 4), JU3 (PWM enabled), JU4 (midspan mode), and JU6 (AC disconnect).

MAX5971B Evaluation Kit

Evaluates: MAX5971B

- 4) Verify that a shunt is installed on jumper JU5 (legacy mode disabled) and on pins 1-5 of jumper JU7 (0x40 address).
- 5) Connect the -32V to -60V DC power supply to the metal VEE banana jack and the supply ground to the metal GND banana jack. Do not turn on the power supply until all connections are completed.
- 6) Connect a PD to the Ethernet output port RJ45 connector (J2) on the EV kit's MagJack module. This step is optional if network connectivity and/or a PD is not required.
- 7) Connect the EV kit's network data input port J1 LAN to the corresponding data LAN connection. **Note:** This step is optional if network connectivity is not required.
- 8) Turn on the power supply and set it to -54V.
- 9) Connect the USB cable from the PC to the EV kit board. A **New Hardware Found** window pops up when installing the USB driver for the first time. If a window is not seen that is similar to the one described above after 30s, remove the USB cable from the board and reconnect it. Administrator privileges are required to install the USB device driver on Windows.
- 10) Follow the directions of the **Found New Hardware** window to install the USB device driver. Manually specify the location of the device driver to be **C:\Program Files\MAX5971B** (default installation directory) using the **Browse** button. During device driver installation, Windows may show a warning message indicating that the device driver Maxim uses does not contain a digital signature. This is not an error condition and it is safe to proceed with installation. Refer to the USB_Driver_Help.PDF document included with the software for additional information.
- 11) Start the EV kit software by opening its icon in the **Start | Programs** menu.
- 12) Observe as the program automatically detects the USB interface circuit, starts the main program, and then detects the I²C-compatible address configured for the IC.
- 13) Select the **BitMap Controls** tab at the top of the GUI (Figure 3).
- 14) Load and run the Power_on.smb macro program from the **File | Open | Run Macro** menu bar. The script automatically runs after selecting **Open**.
- 15) The network output port's yellow and green status LEDs on J2 should be lit.
- 16) Four other example macros allow quick testing of the manual mode, auto mode, semiauto mode,

and with DC and/or AC load-disconnect detection. These macros are:

- TEST#1_MANUAL_MODE.SMB
- TEST#2_AUTO_MODE_DC.SMB
- TEST#3_AUTO_MODE_AC.SMB (JU6 not installed)
- TEST#4_SEMIAUTO_MODE.SMB

Note: JU7 must be on pins 1-5 (0x40 address) for these macros.

- 17) Test points TP11, TP13 (VEE), and TP2 (GND) are provided on the PCB to observe the desired signals with an oscilloscope or voltage meter. **Use an isolated oscilloscope for probing with respect to VEE or RTN.**
- 18) Pressing pushbutton switch SW1 shuts down the PSE output DC power and resets U1. The software must be relaunched after a pushbutton reset.

Note: The GND banana jack is more positive than the VEE or RTN banana jacks. **Use an isolated oscilloscope for probing with respect to VEE or RTN.**

Note: An uninstall program is included with the software. Click on the UNINSTALL icon to remove the EV kit software from the hard drive.

Detailed Description of Software

A mouse or the keyboard's Tab key is used to navigate various items on the main window (Figure 1). The EV kit software features three tabs: **Configuration, Events and Status**, and **BitMap Controls**. Most of the main window's available functions and a few more can be evaluated by using the pulldown menu. The left status bar at the bottom of the main window provides the USB interface circuit status. The center status bar provides the current EV kit and macro engine status.

Software Startup

Upon starting the program, the EV kit software starts in the **Auto Read** state. The software automatically detects the **Slave Address** and begins reading the contents of each register from the IC, updating each tab sheet. The software starts up with the **Events and Status** tab selected.

Events and Status Tab

The **Events and Status** tab sheet (Figure 1) provides the EV kit's system and port events/status information obtained from the IC registers. The **System Events and Status** group box provides system-level information on the VEE power supply, present operating mode, and address in hexadecimal and decimal formats. The **Port Events** group box provides the PSE port event or change status. The **Port Status** group box provides the PSE port

MAX5971B Evaluation Kit

Evaluates: MAX5971B

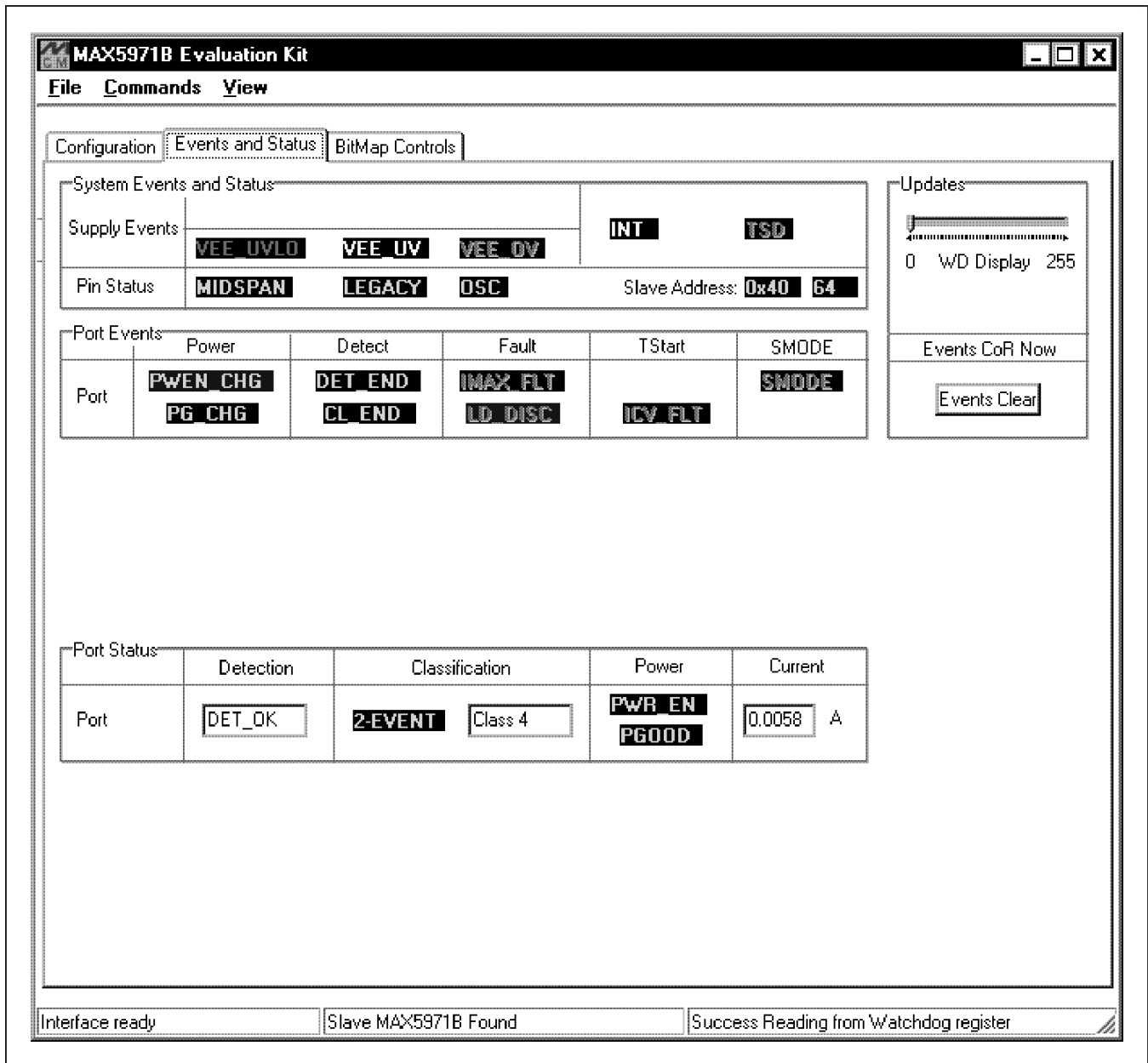

Figure 1. MAX5971B EV Kit Software (Events and Status Tab)

operating status during detection, classification, and current usage by the connected PD.

Configuration Tab

The **Configuration** tab sheet (Figure 2) provides a high-level method of configuring the EV kit as a single-port PSE. System and port-level configurations can be made on this tab. Also, the IC's watchdog timer, IC, or the port can be immediately reset using the **Reset** button. All other configuration changes on this tab take place after the **Update MAX5971B** button has been pressed.

To view a specific port event or status after updating, select the **Events and Status** tab. The port's operating mode, disconnect mode, detection/classification, and various power settings can be set independently. After configuring the port or making system changes, press the **Update MAX5971B** button to write these changes to the IC, thus updating the EV kit's PSE port. Certain configurations may not be enabled, depending on the IC's current state or status.

MAX5971B Evaluation Kit

Evaluates: MAX5971B

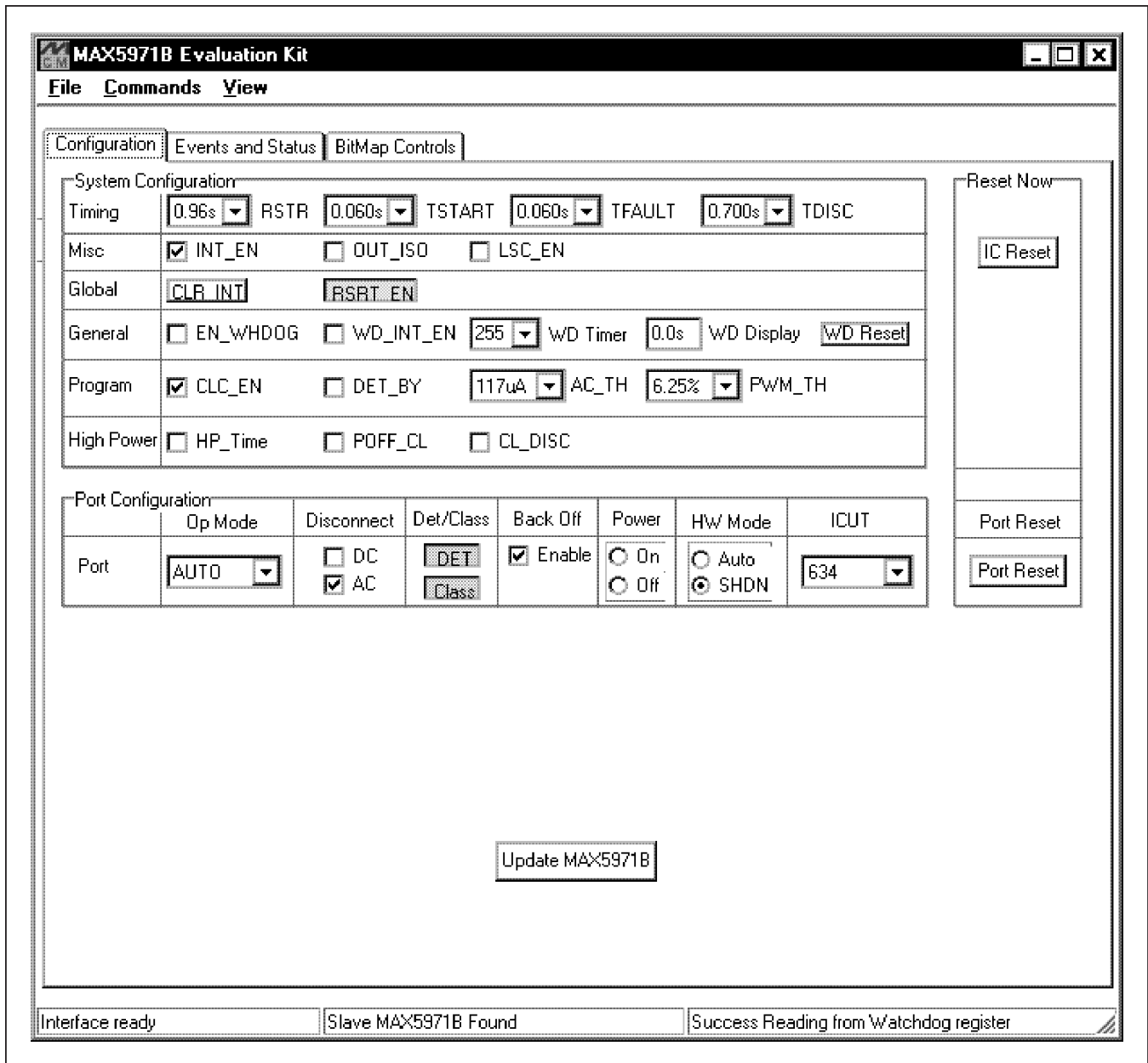

Figure 2. MAX5971B EV Kit Software (Configuration Tab)

BitMap Controls Tab

The **BitMap Controls** tab (Figure 3) provides a bit-level method of configuring the EV kit as a single-port PSE. The IC's register contents are placed on the appropriate line of the **Register Read** tables in binary and hexadecimal format. If data changes between the next register read, the updated register hexadecimal data is displayed in red and blinks four times. The blink rate can be changed in the **Commands | Red Hex Data Blink Rate** menu bar. The status bar at the bottom left of the main window indicates the USB interface circuit status. The center status bar indicates the current EV kit and macro engine status.

Autoread and Run-Macro State Controls

When the **Auto Read** checkbox is checked, the program continuously updates the main window registers and is operating in the autoread state. In the autoread state, data can be written to the IC by entering or selecting the desired data in the **Register Address** and **Hexadecimal Data** or **Binary Data** combo boxes. Pressing the **Write Byte** button writes the combo box data to the IC. To perform an immediate register read, enter or select the desired **Register Address** and press the **Read Byte** button. Hexadecimal or binary data can be entered into the **Hexadecimal Data** or **Binary Data** combo boxes and then the alternate combo box displays the corresponding number in the respective number base.

MAX5971B Evaluation Kit

Evaluates: MAX5971B

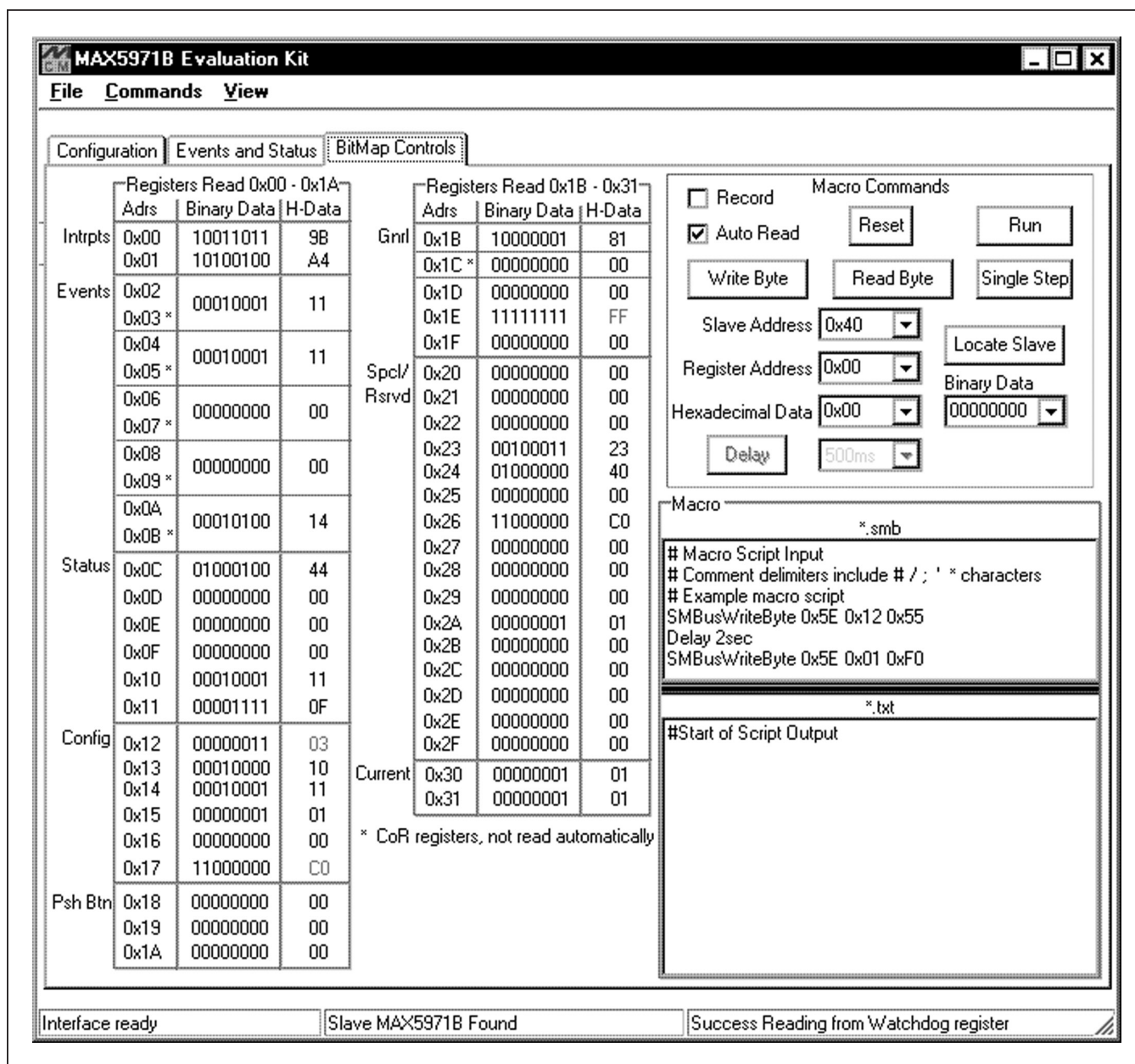

Figure 3. MAX5971B EV Kit Software (BitMap Controls Tab)

If the **Auto Read** checkbox is unchecked, the program's main window displays register data from the last read. To obtain current data, a **Read Byte** must be performed after selecting the appropriate register address from the **Register Address** combo box. Autoread state does not read the clear-on-read (CoR) registers.

A macro can be run after loading the file from the **File | Open Macro** menu bar. The opened macro is displayed in the upper half of the **Macro** edit field and has an smb file extension. Pressing the **Run** button runs the macro to completion, with the output displayed in the **Macro Script Output** edit field. Each edit box can be sized relative to

the other half using the splitter bar above the **Script Output** text. Pressing the **Single Step** button instead of the **Run** button causes the macro to execute a single line with each activation of the **Single Step** button. The **Reset** button is used to reset the macro script engine and clear the **Macro Script Output** edit field. A macro can be run regardless of the **Auto Read** checkbox status. A macro can also be run immediately after opening by using the **File | Open/Run Macro** menu item, selecting the desired macro to run, and pressing the **Open** button. Pressing the **Cancel** button exits this feature.

MAX5971B Evaluation Kit

Evaluates: MAX5971B

The **Locate Slave** button is used to search for a device located on the I²C serial interface whose address has been changed while the software was running. The valid IC slave addresses are configured by jumper JU7 to one of four addresses: 0x40, 0x42, 0x44, or 0x46. The IC does respond to global address 0x60, although the EV kit hardware cannot be set to this specific address.

Record Macro State Controls

When the **Record** checkbox is checked, the program automatically enters the record macro state and disables certain buttons and menus. Selecting the **Commands | Clear Script Input** menu item clears any script currently in the **Macro** script input edit field. Comment lines in a macro script begin with a # / ; ' * character. A line of script is entered by selecting the appropriate **Slave Address**, **Register Address**, and entering the desired **Hexadecimal Data** or **Binary Data** in the respective combo box. Pressing the **Write Byte** or **Read Byte** button then enters the script into the **Macro** input edit field. For time delays in a macro, select the desired delay time from the combo box on the right side of the **Delay** button and then press the **Delay** button. The macro must be saved before exiting the record macro state using the **File | Save Macro** menu item. The macro file must have an smb file extension name.

To edit a previously saved macro, open the macro using the **File | Open Macro** menu item and make the desired edits. The modified file must be saved prior to exiting the record macro state. Uncheck the **Record** checkbox to exit the record macro state. Additionally, a macro can be created or edited using a plain text editor in “text mode.” The file must be saved with an smb extension.

General-Purpose Advanced User Interface Utility

There are two methods for communicating with the IC: through the main window display or through the general-purpose **Advanced User Interface** utility using the **View | Interface** menu item. The utility configures the I²C interface parameters, such as start and stop bits, acknowledgments, and clock timing. The **2-wire interface** tab (Figure 4) allows the user to send general-purpose I²C commands using the **SMBus-WriteByte/ReadByte** and **WriteWord/ReadWord** commands. For more information on the differences between the I²C interface and the SMBus™ interface, refer to Application Note 476: *Comparing the I²C Bus to SMBus*, available at www.maxim-ic.com. When using the **Advanced User Interface** utility, the main window display no longer keeps track of changes sent to hardware. The EV kit can be reinitialized to the startup screen settings by first closing the **Advanced User Interface** utility, resetting the

IC by pressing the reset pushbutton switch (SW1), and relaunching the software.

The **Hunt for active listeners** button scans the entire 2-wire address space, reporting each address that is acknowledged. The **SMBusWriteByte** transmits the device address, command, and 1 byte of data. The **SMBusReadByte** transmits the device address, command, and then retransmits the device address and reads 1 byte of data. The **SMBusWriteWord** and **SMBusReadWord** operate the same, except 2 bytes of data are used.

General Troubleshooting

Problem: Software reports it cannot find the USB interface circuit.

- Is the USB communications cable connected?
- Is the USB interface circuit power LED (D201) lit?
- Has Windows plug-and-play detected the board? Bring up Control Panel → System → Device Manager, and look at what device nodes are indicated for the USB. If there is an unknown device node attached to the USB, delete it—this forces plug-and-play to try again.

Problem: Software reports MAX5971B IC not found, exiting program.

- Are the OPTO_SCL and OPTO_SDA signals pulled up to OPTO_VCC (3.3V)?
- If using jumper wires to connect, could the OPTO_SCL and OPTO_SDA signals be swapped? Could the OPTO_GND ground return be missing?

Detailed Description of Hardware

The MAX5971B EV kit features a 10/100/1000BASE-TX Ethernet single-port PSE controller circuit for -54V supply rail systems. The EV kit's PSE circuit uses the IEEE 802.3af/at-compliant MAX5971B PSE controller featuring an integrated n-channel power MOSFET and an on-board single 1Gb x 1Gb MagJack module (integrated in J2) to form the basic portion of a PSE circuit. The EV kit has been designed as an IEEE 802.3af/at-compliant PSE and demonstrates all the required functions such as PD discovery, classification, current-limit control of a connected PD at the Ethernet output port, and AC-/DC-disconnect detection. A PC can be used to communicate with the slave device over the I²C interface, optically coupled logic, and the 2-wire-to-USB-port interface circuit.

The EV kit PSE circuit requires a -32V to -60V power supply (-54V supply rail) capable of supplying 1A or more to the EV kit's GND and VEE metal banana jacks or

SMBus is a trademark of Intel Corp.

MAX5971B Evaluation Kit

Evaluates: MAX5971B

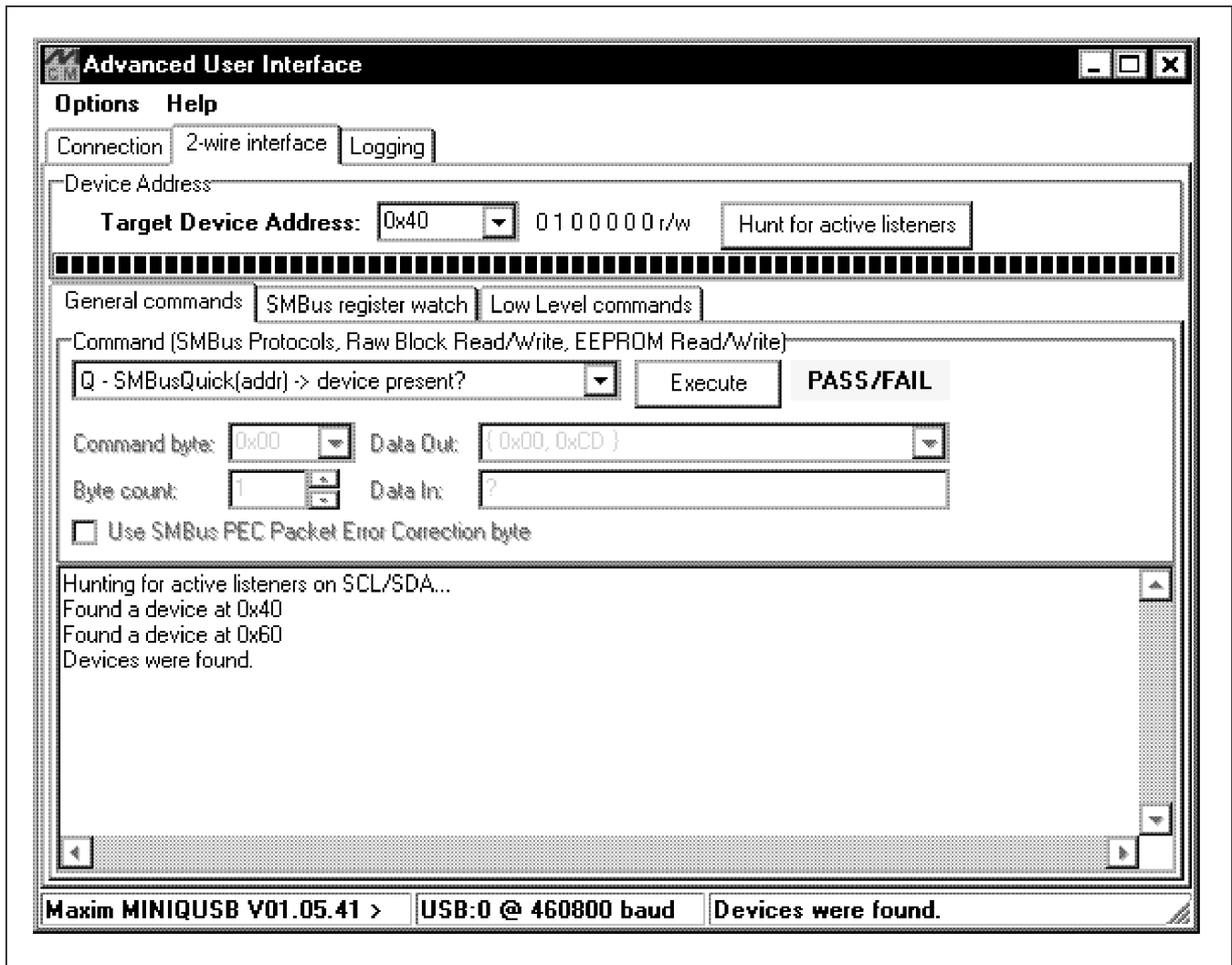

Figure 4. Advanced User Interface Window (2-Wire Interface Tab)

PCB pads. A separate +3.3V power supply capable of supplying 35mA is also required for the IC's optically isolated I²C-compatible 2-wire interface when the optically isolated USB interface circuit is not used. A MAX6765 linear regulator (U2) provides the required +3.3V for the optical isolation at the PSE side.

The IC controls the -54V DC power to the output port by regulating the port's current. The current is fed to the J2 Ethernet output port's RJ45 output module. An IEEE 802.3af/at-compliant PD connects to the Ethernet output port (J2) on the EV kit. The PD can be located up to 350ft from the EV kit when connected with a twisted 4-pair Ethernet cable. The 10/100/1000BASE-TX magnetic module (J2) is decoupled to the EV kit's chassis ground internally. The EV kit's isolated chassis ground (Chassis_GND) PCB pad connects to the network system ground. Note that the 10/100/1000BASE-TX magnetic output module RJ45 jack (J2) is rated for up to 700mA of

current. See the *35W or More Power Operation Without an Ethernet Connection* section for operation at or above 35W.

The EV kit features configurable operational modes, PD detection (including legacy PD detection), PD classification, overcurrent protection, current foldback, undervoltage/overvoltage protection (+28.5V, +62.5V (typ) (GND - V_{EE})), respectively), AC-/DC-disconnect monitoring, high-power Class 5 mode operation, and port current information through the I²C interface. The Class 5 overcurrent and current-limit protection can be reconfigured through jumpers or can be programmed through the software.

The IC starts up in automatic operation mode and pushbutton switch SW1 can be used to reset the IC or enter shutdown mode. Semiautomatic and manual modes can only be accessed through their respective register using the software's high-level **Configuration** window.

MAX5971B Evaluation Kit

Evaluates: MAX5971B

PD-blocking diode D4 can be bypassed to reduce power dissipation when AC-disconnect monitoring is not required. The IC features an internal triangular-wave oscillator for AC-disconnect detection and can be bypassed to operate in DC-disconnect detection mode. The internal oscillator must be shut down using jumper JU6 if AC-disconnect detection is not required.

The output port also features a 600W overvoltage transient suppressor diode (D2) and decoupling capacitor (C5) for transient protection at the output port. The EV kit's input port power rails (GND and VEE) are protected by reverse-protection diode D5.

Test points and jumpers have been provided for voltage probing and current measurements of the power circuit. **Additionally, since the GND is more positive than VEE or RTN, use an isolated oscilloscope when probing signals with respect to VEE or RTN.** Yellow and green LEDs on output module J2 indicate when the port's power is turned on and the PoE status, respectively.

The EV kit can also be reconfigured for interfacing without connecting to an Ethernet system. Banana jacks are included for the PSE GND and RTN output power sources for this method of evaluation. **Since the GND is more positive than VEE or RTN, use an isolated oscilloscope when probing signals with respect to VEE or RTN.**

The EV kit provides optical isolation for the I²C-compatible 2-wire interface, required by the IC operating as a slave device, by optical couplers U3 and U4. The optically isolated interface connects to a computer's USB port through the USB interface circuit. The EV kit's I²C-compatible 2-wire interface can be reconfigured for interfacing to a stand-alone microcontroller for isolated (2-wire) or nonisolated (2-wire) serial operation. A separate +3.3V power supply capable of supplying 35mA is required for the IC's nonisolated I²C-compatible 2-wire interface.

The optical isolation consists of optocoupler U3, which provides galvanic isolation for the serial-interface clock line (SCL) and serial-interface input data line (SDA) signals. Optocoupler U4 provides galvanic isolation for the serial output and data line (SDA) and $\overline{\text{INT}}$ signals. The SCL and SDA signals' 2-wire serial interface are combined on the isolated 2-wire side prior to feeding logic buffers U5 and U6. The respective two-hole PCB pads (OPTO_SCL, OPTO_SDA, OPTO_ $\overline{\text{INT}}$, OPTO_GND, and OPTO_VCC) are used for 2-wire isolated stand-alone operation. For nonisolated stand-alone 2-wire operation, jumper JU8 shorting traces must be cut open and then the SCL, SDA, $\overline{\text{INT}}$, and 3_3V PCB jumper holes must be connected to the microcontroller circuit. **Note:** The EV kit's provided 3_3V is at +3.3V. The OPTO_GND, GND, and VEE planes are isolated by the optical couplers.

Since the GND is more positive than VEE or RTN, use an isolated oscilloscope when probing signals with respect to VEE or RTN.

The device slave address is configured by jumper JU7 and can be configured to one of four addresses: 0x40, 0x42, 0x44, or 0x46. Global address 0x60 is accepted by the IC regardless of the jumper settings. See Table 9 for more information on setting the device slave address.

Jumper Selection

The EV kit features several jumpers to reconfigure the kit for various PSE configurations, operating modes, and PD requirements. Additionally, PCB pads and jumpers are provided for connecting an external microcontroller and setting the I²C slave address, respectively.

High-Power Class 5 and ILIM1/ILIM2 Selection

The EV kit features two jumpers to configure the IC's PSE PD classification mode, Class 0–Class 4 mode, or high-power Class 5 mode. Jumper JU1 sets the IC's ILIM1 configuration and JU2 sets the ILIM2 configuration. Table 1 lists the jumper options for the modes used to detect a valid PD connected to the PSE Ethernet output port. Refer to the MAX5971B IC data sheet for more information on all classification modes available.

LED Driver PWM Enable and Port PoE Status

The EV kit features a 2-pin jumper (JU3) to enable or disable the IC's internal PWM driver for the LED pin. The IC's LED pin also serves as a port-status indicator using the LED driver. The RJ45 connector (J2), providing data and power at the output port, features 2 LEDs—a yellow LED indicating that the EV kit is powered by -54V and a green PSE port-status LED. Table 2 lists the LED driver jumper options and Table 3 provides the port status. Refer to the MAX5971B IC data sheet for more information on the multifunction LED features.

Midspan/End-Point PoE Selection and Configuration

The EV kit features a 2-pin jumper (JU4) to set the IC for midspan or end-point operation. The PSE circuit must also be reconfigured for operating in midspan or end-point configuration.

Table 4 lists the jumper options and Table 5 lists the PSE circuit resistor changes for the two configurations of operation. In Table 5, installed resistors are 0 Ω , 120 Ω surface-mount components. Refer to the MAX5971B IC data sheet for more information on the configurations.

Legacy High-Capacitance-Detection Operation

The EV kit features a 2-pin jumper (JU5) to set the IC's initial startup legacy operational mode. In legacy mode, PD signature capacitances up to 47 μF (typ) are accepted. Table 6 lists the jumper options. Refer to the MAX5971B IC data sheet for more information.

MAX5971B Evaluation Kit

Evaluates: MAX5971B

Table 1. ILIM1/ILIM2 Functions (JU1, JU2)

IC CLASSIFICATION	ILIM1 PIN (JU1)	ILIM2 PIN (JU2)	OVERCURRENT THRESHOLD (mA)	CURRENT LIMIT (mA)
Class 0–Class 4*	Not installed	Not installed	Class 5 disabled	Class 5 disabled
Class 5	Installed	Not installed	748	850
Class 5	Not installed	Installed	792	900
Class 5	Installed	Installed	836	950

*Default position. Refer to the MAX5971B IC data sheet for more information on Class 0–Class 4 overcurrent and current-limit information.

Table 2. PWMEN Functions (JU3)

SHUNT POSITION	PWMEN PIN	LED PWM OPERATION
Not installed*	Internally pulled high	Enabled
Installed	Connected to VEE through resistor R12	Shutdown

*Default position.

Table 3. Green LED Status (J2)

GREEN LED	J2 PORT STATUS
Off	Not powered or disconnected
On	Powered, valid PD
Blinking 2 flashes	Overcurrent fault during power-on
Blinking 5 flashes	Detected invalid low-/high-discovery signature resistance

Table 4. Midspan Functions (JU4)

SHUNT POSITION	MIDSPAN PIN	PSE CONFIGURATION
Not installed*	Internally pulled high	Midspan
Installed	Connected to VEE through resistor R13	End point

*Default position.

Table 5. PSE Circuit Changes for Midspan/End-Point Configuration

CONFIGURATION	RESISTOR			
	R5	R6	R7	R8
Midspan*	Not installed	Not installed	Installed	Installed
End point	Installed	Installed	Not installed	Not installed

*Default position.

Table 6. Legacy Modes (JU5)

SHUNT POSITION	LEGACY PIN	LEGACY MODE
Not installed	Internally pulled high	Enabled, detect high capacitance
Installed*	Connected to VEE through resistor R15	Disabled

*Default position.

Table 7. OSC and AC-/DC-Disconnect-Detection Functions (JU6)

SHUNT POSITION	OSC PIN	RESISTOR		DISCONNECT-DETECTION MODE
		R3	R9	
Installed	Connected to VEE	Not installed	Installed	DC-disconnect detection
Not installed*	Connected to VEE through capacitor C6	Installed	Not installed	AC-disconnect detection, uses IC's internal oscillator

*Default position.

MAX5971B Evaluation Kit

Evaluates: MAX5971B

AC-Disconnect Monitoring Oscillator and AC-/DC-Disconnect Operation

The EV kit features a 2-pin jumper (JU6) to disable the IC's internal triangular-wave oscillator at the OSC pin. The oscillator is used for AC-disconnect monitoring of the PD and is disabled for DC-disconnect operation. For AC-disconnect operation, the internal oscillator is used along with RCD components R3, C4 and D3, and blocking-diode D4. Perform a power-on or reset the IC using switch SW1 to effect the changes.

For DC-disconnect operation, shut down the internal oscillator by installing a shunt on jumper JU6. Then remove resistor R3 and install a 0Ω 0402 surface-mount resistor on the R9 pads to bypass blocking-diode D4. Diode D3 remains installed. Refer to the *AC Disconnect Monitoring* and *DC Disconnect Monitoring* sections in the MAX5971B IC data sheet for additional information. Table 7 lists the jumper options for the oscillator and AC/DC configurations. Refer to the MAX5971B IC data sheet for more information.

Reset/Shutdown and Automatic Modes

The EV kit features switch SW1 to reset the IC or set the IC's initial startup operational mode to auto mode. Semiautomatic and manual modes can only be accessed through their respective register using software. Refer to the MAX5971B IC data sheet for more information. Table 8 lists the switch options.

I²C-Compatible 2-Wire Slave address Selection

The EV kit features a 2-pin jumper (JU7) to set the slave address to one of four addresses: 0x40, 0x42, 0x44, or 0x46 of the slave address on the I²C-compatible 2-wire interface. Global address 0x60 is accepted by the IC regardless of the jumper settings. The EV kit's software automatically sets the LSB for the proper read/write command. Table 9 lists the jumper addressing options.

Stand-Alone Microcontroller Interface (Isolated/Nonisolated)

The EV kit features PCB pads and a jumper to interface directly with a microcontroller. The 8-pin (2 x 4) jumper (JU8) has shorting connections on the bottom layer that must be cut open to disable the optical coupler interface for nonisolated evaluation. The jumper shorting connections must be in place for evaluating an isolated stand-alone microcontroller interface. Table 10 lists the selectable jumper options.

35W or More Power Operation Without an Ethernet Connection

The 10/100/1000BASE-TX magnetic output module RJ45 jack (J2) is rated for up to 700mA of current and cannot be used for PSE operation at greater than 35W power. The EV kit features PCB pads and banana jacks to interface directly with the EV kit's output port power when operating at 35W or more. Use the GND and RTN PCB pads or jacks to access the output port's power without an Ethernet connection.

External +3.3V Operation

The EV kit's on-board +3.3V linear regulator circuit can be reconfigured to operate the EV kit circuit with an externally supplied +3.3V DC source. The EV kit's on-board linear regulator (U2) must be disabled and several components reconfigured to operate the EV kit with an externally supplied +3.3V source as follows:

- Cut open the shorting traces on resistors R31 and R32 pads.
- Connect the external +3.3V ground terminal to the VEE PCB pad or VEE test point (TP13 or TP11).
- Connect the external supply positive to the 3_3V test point (TP12).

The externally supplied +3.3V DC source must be able to supply 50mA of current or more.

IC Pins' Signal Measurements

The EV kit features test points to facilitate voltage measuring at the ports' respective LED, ILIM1, ILIM2, PWMEN, MIDSPAN, LEGACY, and EN pin signals of the IC. For the VEE connection, test points TP11 and TP13 can be used.

The output port current can be measured by replacing any output port single resistor (R5 or R6) when operating in midspan, or when operating in end point (R7 or R8). Replace the respective resistor with a $1\Omega \pm 1\%$ 1206 surface-mount resistor.

J2 Port LED Status +3.3V Operation

The EV kit's J2 port green LED status indicator is configured to operate from the -54V supply. Alternatively, the green LED status indicator can be reconfigured to operate off the on-board +3.3V linear regulator circuit. To evaluate this mode of operation, two components on the EV kit must be reconfigured as follows:

- Remove resistor R29.
- Install a 200Ω 0805 surface-mount resistor at R30.

MAX5971B Evaluation Kit

Evaluates: MAX5971B

Table 8. EN Operational Modes (SW1)

SWITCH POSITION	EN PIN	EV Kit OPERATION MODE
Not pressed	Internally pulled high	Automatic
Pressed	Connected to VEE through resistor R16	Reset or shutdown

Table 9. AD0 Slave Address Selection (JU7)

SHUNT POSITION (AD0 BIT)	AD0 PIN	SLAVE ADDRESS	READ/WRITE
1-5*	Connected to VEE	0x40	Read
		0x41	Write
1-3	Connected to 3_3V	0x42	Read
		0x43	Write
1-2	Connected to SCL	0x44	Read
		0x45	Write
1-4	Connected to SDA	0x46	Read
		0x47	Write

*Default position.

Table 10. Jumper JU8 and Microcontroller PCB Pads Function

JU8 PIN NUMBER SHORT POSITION	ISOLATION MODE	EV KIT PCB PAD TO MICROCONTROLLER CONNECTION
1-2 (Shorted)*	Isolated	OPTO_VCC PCB pad connects to the microcontroller +3.3V power supply.
3-4 (Shorted)*	Isolated	OPTO_SCL PCB pad connects to the microcontroller serial-clock line.
5-6 (Shorted)*	Isolated	OPTO_SDA PCB pad connects to the microcontroller SDA data line.
7-8 (Shorted)*	Isolated	OPTO_ $\overline{\text{INT}}$ PCB pad connects to the microcontroller interrupt pin.
—	Isolated	OPTO_GND PCB pad connects to the microcontroller power-supply ground.
1-2 (Cut open)**	Nonisolated	JU8-2: 3_3V pin receives power from the microcontroller supply.
3-4 (Cut open)	Nonisolated	JU8-4: SCL pin connects to the microcontroller serial-clock line.
5-6 (Cut open)	Nonisolated	JU8-6: SDA pin connects to the microcontroller SDA data line.
7-8 (Cut open)	Nonisolated	JU8-8: $\overline{\text{INT}}$ pin connects to the microcontroller interrupt pin.
**	Nonisolated	TP11 or TP13: VEE connects to the microcontroller power-supply ground.

*Default set by PCB trace.

**See the External +3.3V Operation section for configuring the EV kit in nonisolated mode.

MAX5971B Evaluation Kit

Evaluates: MAX5971B

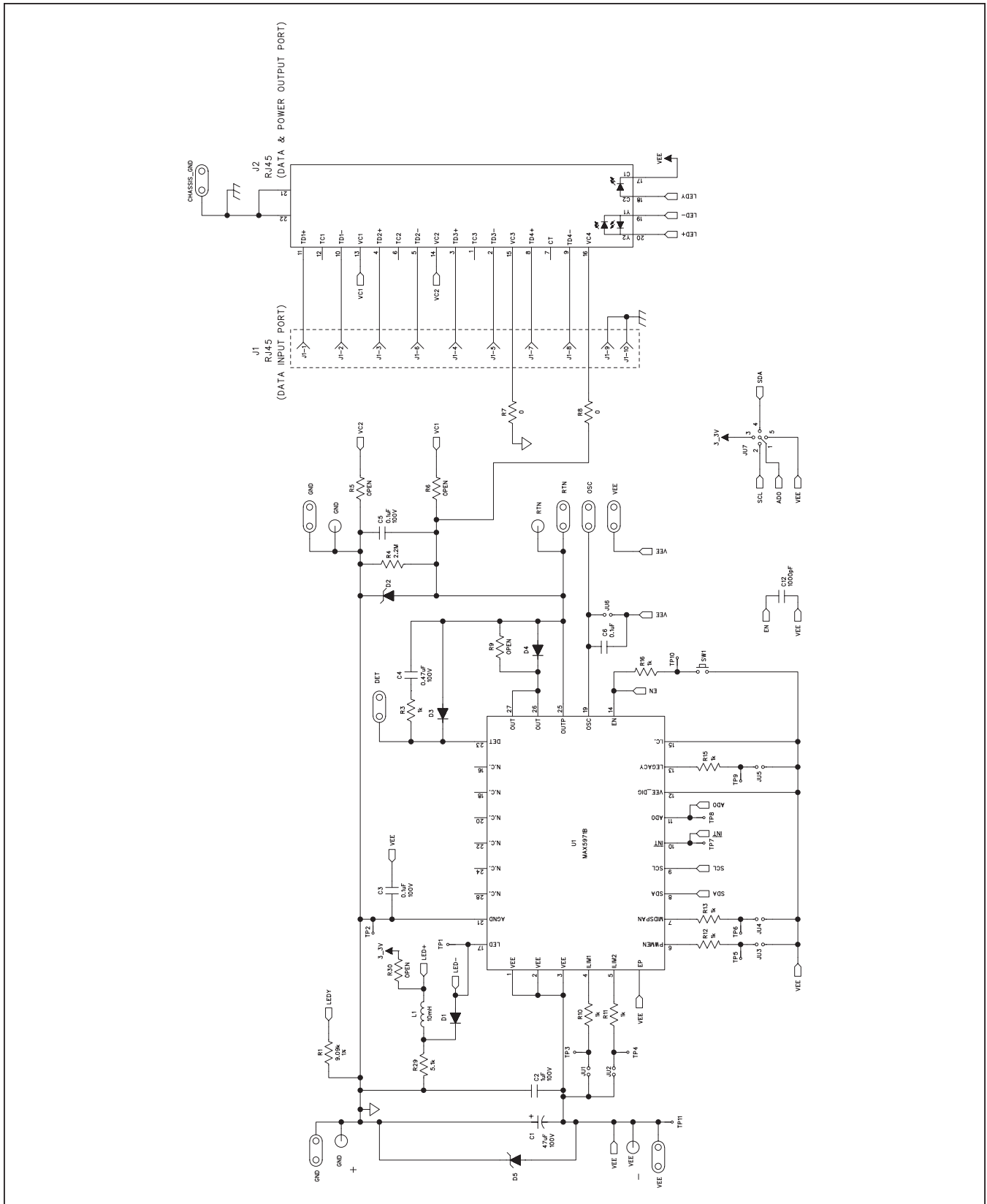

Figure 5a. MAX5971B EV Kit Schematic—Controller Circuit (Sheet 1 of 3)

MAX5971B Evaluation Kit

Evaluates: MAX5971B

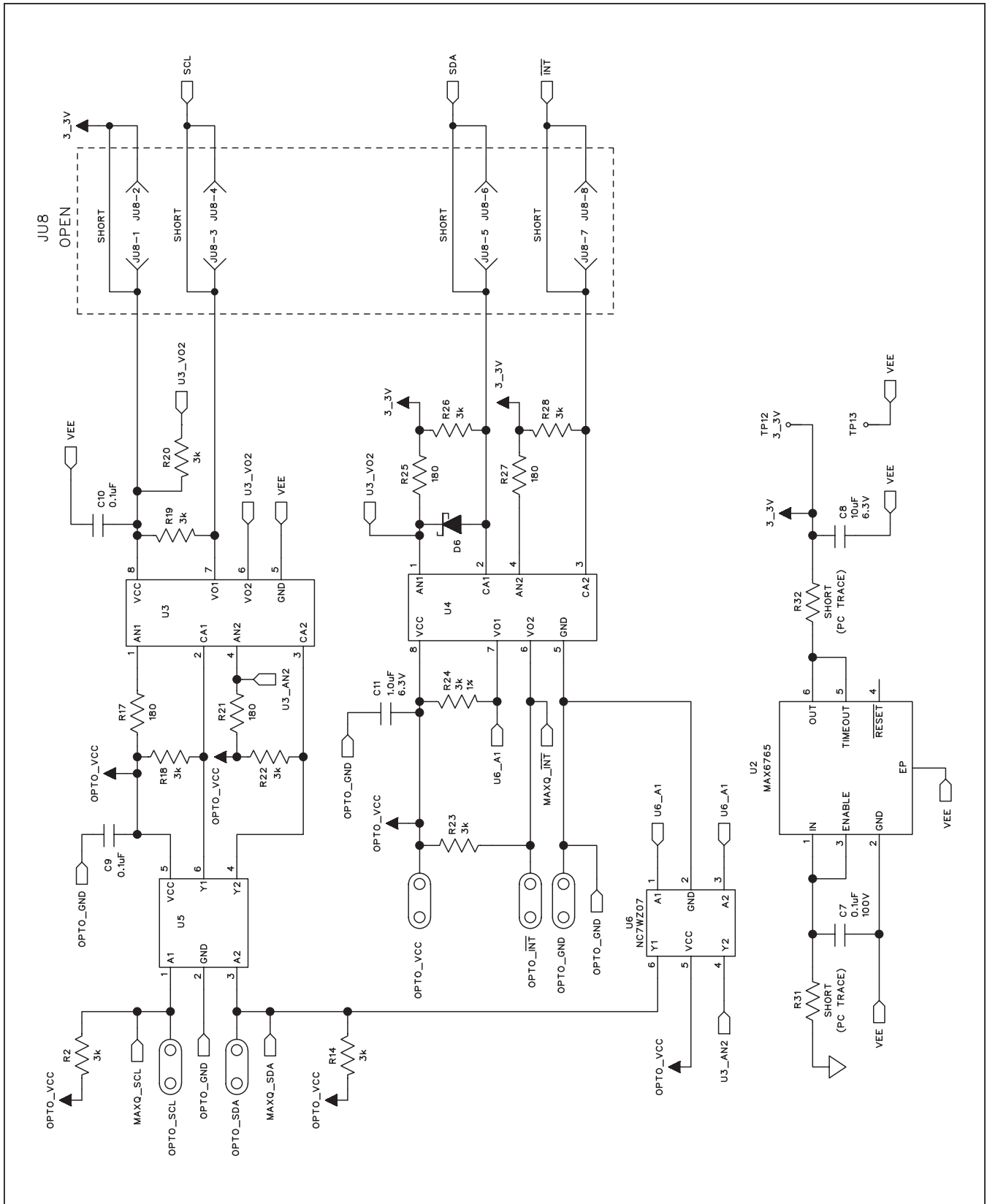

Figure 5b. MAX5971B EV Kit Schematic—LDO and Optical Coupler Circuit (Sheet 2 of 3)

MAX5971B Evaluation Kit

Evaluates: MAX5971B

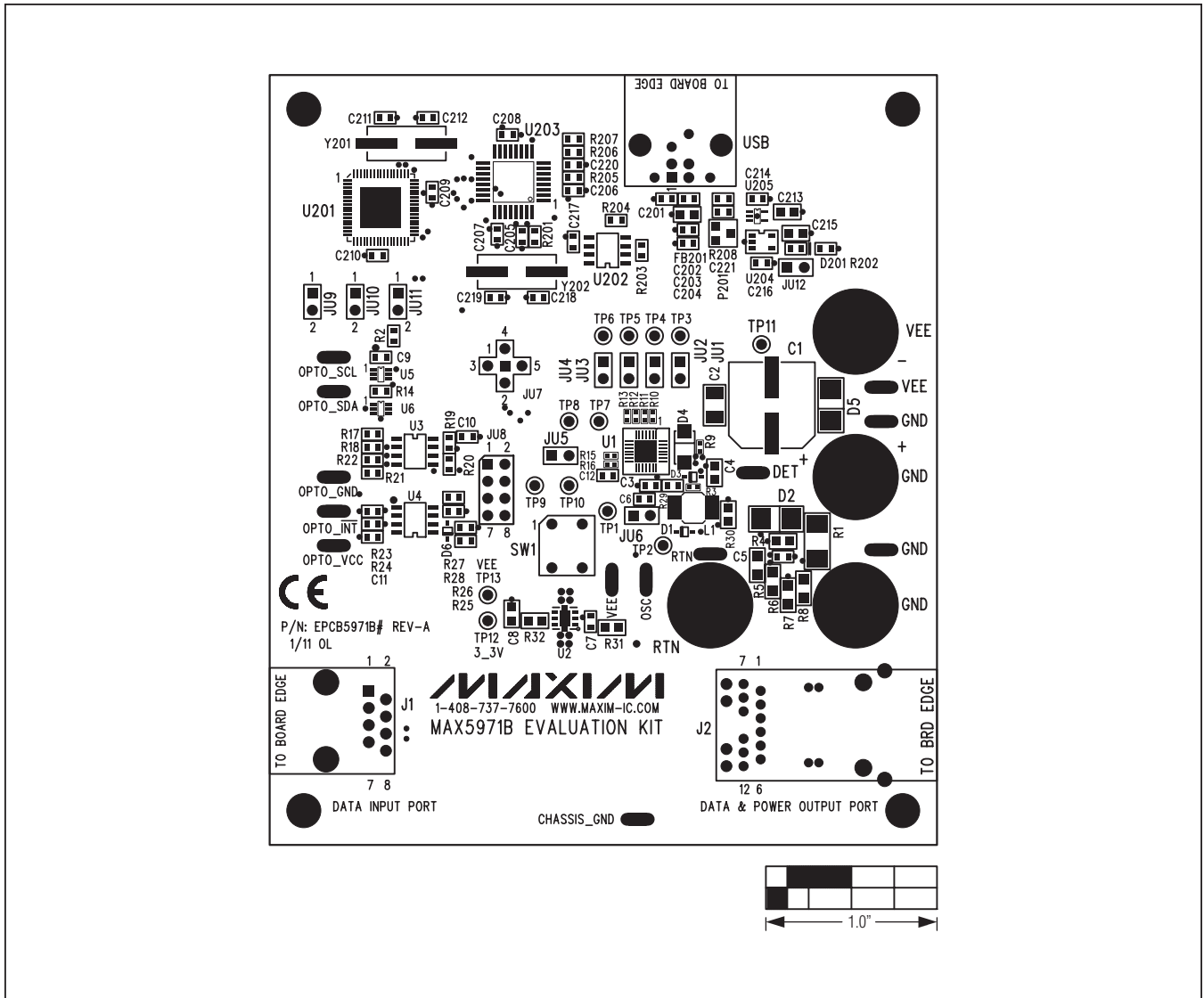

Figure 6. MAX5971B EV Kit Component Placement Guide—Component Side

MAX5971B Evaluation Kit

Evaluates: MAX5971B

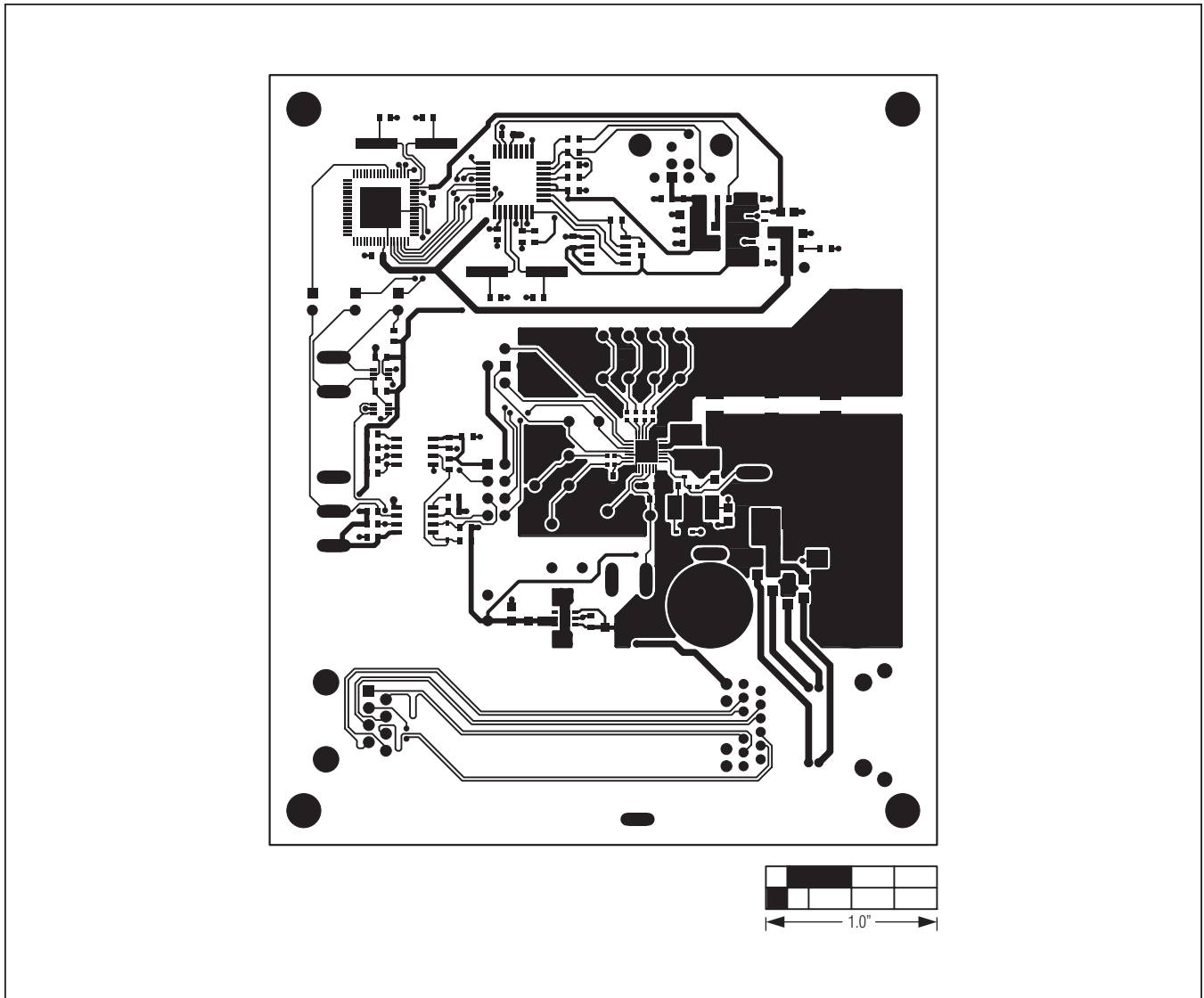

Figure 7. MAX5971B EV Kit PCB Layout—Component Side

MAX5971B Evaluation Kit

Evaluates: MAX5971B

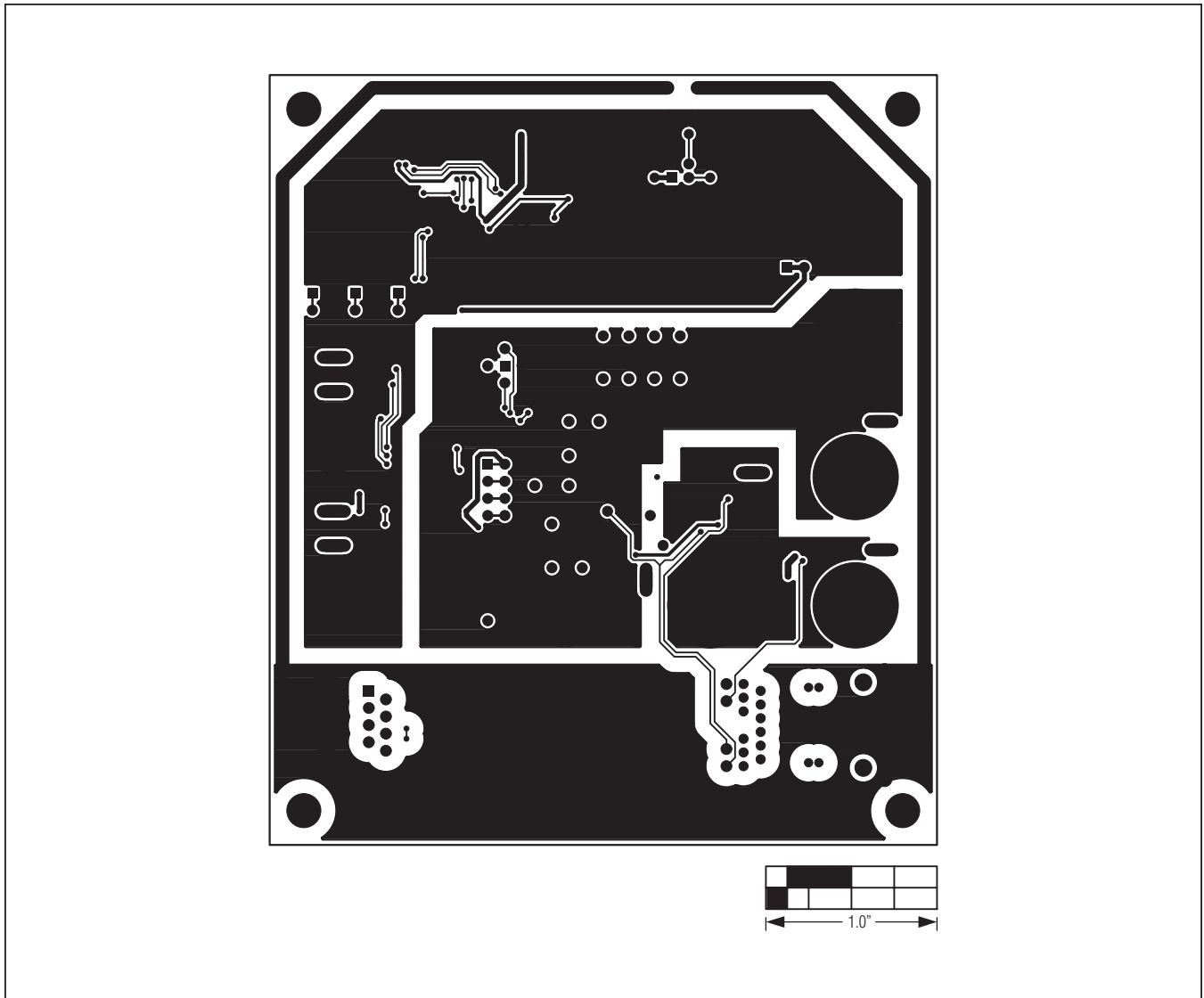

Figure 8. MAX5971B EV Kit PCB Layout—Solder Side

MAX5971B Evaluation Kit

Evaluates: MAX5971B

Ordering Information

PART	TYPE
MAX5971BEVKIT#	EV KIT

#Denotes RoHS compliant.