



MAX6662 Evaluation Kit

Evaluates: MAX6662

General Description

The MAX6662 evaluation kit (EV kit) provides a proven design to evaluate the MAX6662 12-bit + sign temperature sensor with SPI™-compatible serial interface. The EV kit also includes Windows® 2000/XP®- and Windows Vista®-compatible software that provides a simple graphical user interface (GUI) for exercising the features of the MAX6662.

The MAX6662 EV kit PCB comes with a MAX6662MSA+ installed.

SPI is a trademark of Motorola, Inc.

Windows, Windows XP, and Windows Vista are registered trademarks of Microsoft Corp.

Features

- ◆ **Windows 2000/XP- and Windows Vista (32-Bit)-Compatible Software**
- ◆ **USB-PC Connection (Cable Included)**
- ◆ **USB Powered**
- ◆ **Lead(Pb)-Free and RoHS Compliant**
- ◆ **7-Pin Signal Header**
- ◆ **Proven PCB Layout**
- ◆ **Fully Assembled and Tested**

Ordering Information

PART	TYPE
MAX6662EVKIT+	EV Kit

+Denotes lead(Pb)-free and RoHS compliant.

Component List

DESIGNATION	QTY	DESCRIPTION
C1, C101–C105, C111, C121, C131, C141	10	0.1µF ±10%, 16V X7R ceramic capacitors (0603) TDK C1608X7R1C104K
C21	1	4.7µF ±20%, 25V X7R ceramic capacitor (1206) Murata GCM31CR71E475M
C22, C109	2	10µF ±20%, 16V X5R ceramic capacitors (1206) Murata GRM31CR61C106M
C23	0	Not installed, ceramic capacitor
C106, C107, C122, C123	4	22pF ±5%, 50V C0G ceramic capacitors (0603) Murata GRM1885C1H220J
C108	1	1µF ±10%, 16V X5R ceramic capacitor (0603) TDK C1608X5R1C105K
C110	1	0.033µF ±10%, 16V (min) X5R ceramic capacitor (0603) Taiyo Yuden EMK107BJ333KA
D1, D2, D3	3	Red LEDs (0603)
H1	1	7-pin header
J10	1	USB type-B right-angle female receptacle

DESIGNATION	QTY	DESCRIPTION
JU1, JU2, JU3, JU5, JU6, JU8, JU101–JU108	0	Not installed, headers—short (PCB trace)
JU21, JU22	2	3-pin headers
L21, L101	2	Ferrite beads TDK MMZ1608R301A (0603)
R1, R2, R3, R103	4	1.5kΩ ±5% resistors (0603)
R101, R102	2	27Ω ±5% resistors (0603)
R104	1	470Ω ±5% resistor (0603)
R111	1	2.2kΩ ±5% resistor (0603)
R121	1	1.1kΩ ±5% resistor (0603)
R112, R122	2	10kΩ ±5% resistors (0603)
SW122	1	Momentary 6mm pushbutton switch
U1	1	12-bit temperature sensor (8 SO) Maxim MAX6662MSA+
U2	1	3.3V at 500mA LDO regulator (8 µMAX®) Maxim MAX1792EUA33+ (Top Mark: AAAA)
U10	1	UART-to-USB converter (32 TQFP)

µMAX is a registered trademark of Maxim Integrated Products, Inc.



MAX6662 Evaluation Kit

Component List (continued)

DESIGNATION	QTY	DESCRIPTION
U11	1	93C46 type 3-wire EEPROM 16-bit architecture (8 SO)
U12	1	Ultra-high-speed microcontroller (44 TQFP) Maxim DS89C450-ENL+
U13	1	Quad three-state driver (14 SO) Fairchild 74AC125SC
U14	1	Level translator (20 TSSOP) Maxim MAX3002EUP+

DESIGNATION	QTY	DESCRIPTION
Y10	1	6MHz crystal (HCM49) Hong Kong X'tals SSL6000000E18FAF
Y12	1	14.7456MHz crystal (HCM49) Hong Kong X'tals SSM1474560E18FAF
—	2	Shunts
—	1	USB high-speed A-to-B cables, 6ft
—	1	PCB: MAX6662 EVALUATION KIT+

Component Suppliers

SUPPLIER	PHONE	WEBSITE
Fairchild Semiconductor	888-522-5372	www.fairchildsemi.com
Hong Kong X'tals Ltd.	852-35112388	www.hongkongcrystal.com
Murata Electronics North America, Inc.	770-436-1300	www.murata-northamerica.com
Taiyo Yuden	800-348-2496	www.t-yuden.com
TDK Corp.	847-803-6100	www.component.tdk.com

Note: Indicate that you are using the MAX6662 when contacting these component suppliers.

MAX6662 EV Kit Files

FILE	DESCRIPTION
MAX6662EVKIT.exe	Application program
FTD2XX.INF	USB device driver file
UNINST.INI	Uninstalls the EV kit software
USB_Driver_Help.PDF	USB driver installation help file

Quick Start

Required Equipment

- MAX6662 EV kit (USB cable included)
- User-supplied Windows 2000/XP or Windows Vista PC with a spare USB port

Note: In the following sections, software-related items are identified by bolding. Text in bold refers to items directly from the EV kit software. Text in **bold and underlined** refers to items from the Windows operating system.

Procedure

The MAX6662 EV kit is fully assembled and tested. Follow the steps below to verify board operation:

- 1) Visit www.maxim-ic.com/evkitsoftware to download the latest version of the EV kit software, 6662Rxx.ZIP. Save the EV kit software to a temporary folder and uncompress the ZIP file.
- 2) Install the EV kit software on your computer by running the 6662Rxx.msi program inside the temporary folder. The program files are copied and icons are created in the Windows **Start | Programs** menu.
- 3) Verify that all jumpers (JU1, JU2, JU3, JU5, JU6, JU8, JU21, and JU22) are in their default positions, as shown in Table 1.

MAX6662 Evaluation Kit

Evaluates: MAX6662

Table 1. MAX6662 EV Kit Jumper Descriptions

JUMPER	SIGNAL	SHUNT POSITION	DESCRIPTION
JU1	SCLK	Not installed*	U1 SCLK is connected to on-board microcontroller
		PCB trace cut open	U1 SCLK is disconnected from on-board microcontroller
JU2	\overline{CS}	Not installed*	U1 \overline{CS} is connected to on-board microcontroller
		PCB trace cut open	U1 \overline{CS} is disconnected from on-board microcontroller
JU3	SIO	Not installed*	U1 SIO is connected to on-board microcontroller
		PCB trace cut open	U1 SIO is disconnected from on-board microcontroller
JU5	\overline{OT}	Not installed*	U1 \overline{OT} is connected to on-board microcontroller
		PCB trace cut open	U1 \overline{OT} is disconnected from on-board microcontroller
JU6	\overline{ALERT}	Not installed*	U1 \overline{ALERT} is connected to on-board microcontroller
		PCB trace cut open	U1 \overline{ALERT} is disconnected from on-board microcontroller
JU8	VCC	Not installed*	U1 VCC is connected to on-board level translator
		PCB trace cut open	U1 VCC is disconnected from on-board level translator
JU21	VCC	1-2*	U1 VCC is powered by 5V or EXT_VIN
		2-3	U1 VCC is powered by 3.3V from U2
JU22	LDO IN	1-2*	U1 and U2 are powered by 5V from USB
		2-3	U1 and U2 require external user-supplied 5V power

*Default position.

- 4) Connect the USB cable from the PC to the EV kit board. A **New Hardware Found** window pops up when installing the USB driver for the first time. If a window is not seen that is similar to the one described above after 30s, remove the USB cable from the board and reconnect it. Administrator privileges are required to install the USB device driver on Windows.
- 5) Follow the directions of the **Add New Hardware Wizard** to install the USB device driver. Choose the **Search for the best driver for your device** option. Specify the location of the device driver to be **C:\Program Files\MAX6662** (default installation directory) using the **Browse** button. During device driver installation, Windows may show a warning message indicating that the device driver Maxim uses does not contain a digital signature. This is not an error condition and it is safe to proceed with installation. Refer to the USB_Driver_Help.PDF document included with the software for additional information.
- 6) Start the MAX6662 EV kit software by opening its icon in the **Start | Programs** menu. The EV kit software main window appears, as shown in Figure 1.
- 7) **Auto Read** is selected. The configuration register and the limit registers are read from the sensor and the GUI are updated. All alarms read OK.
- 8) The actual room temperature is displayed in group box **0xC1 Temperature Register**.
- 9) In group box **0xC7/0x87 TMAX Critical-Temperature Trip Register**, enter the value **35** and press the **Write** button.
- 10) In group box **0xCB/0x8B THIGH Alarm-Temperature Upper-Boundary Trip Register**, enter the value **30** and press the **Write** button.
- 11) In group box **0xC9/0x89 TLOW Alarm-Temperature Lower-Boundary Trip Register**, enter the value **15** and press the **Write** button.
- 12) Do not change the hysteresis level (default setting 2) in group box **0xC5/0x85 THYST Temperature Hysteresis Register**.
- 13) Apply an external heat source to the MAX6662, sufficient to exceed the programmed THIGH alarm temperature threshold. The **> Alarm Temperature Upper Boundary** is highlighted, the ALERT pin status indicator changes to **ALERT pin: 0 active**, the ALERT pin of the MAX6662 goes low, and LED D1 on the evaluation board turns on. The integer part of the temperature must be greater than THIGH to trip the indicators.

MAX6662 Evaluation Kit

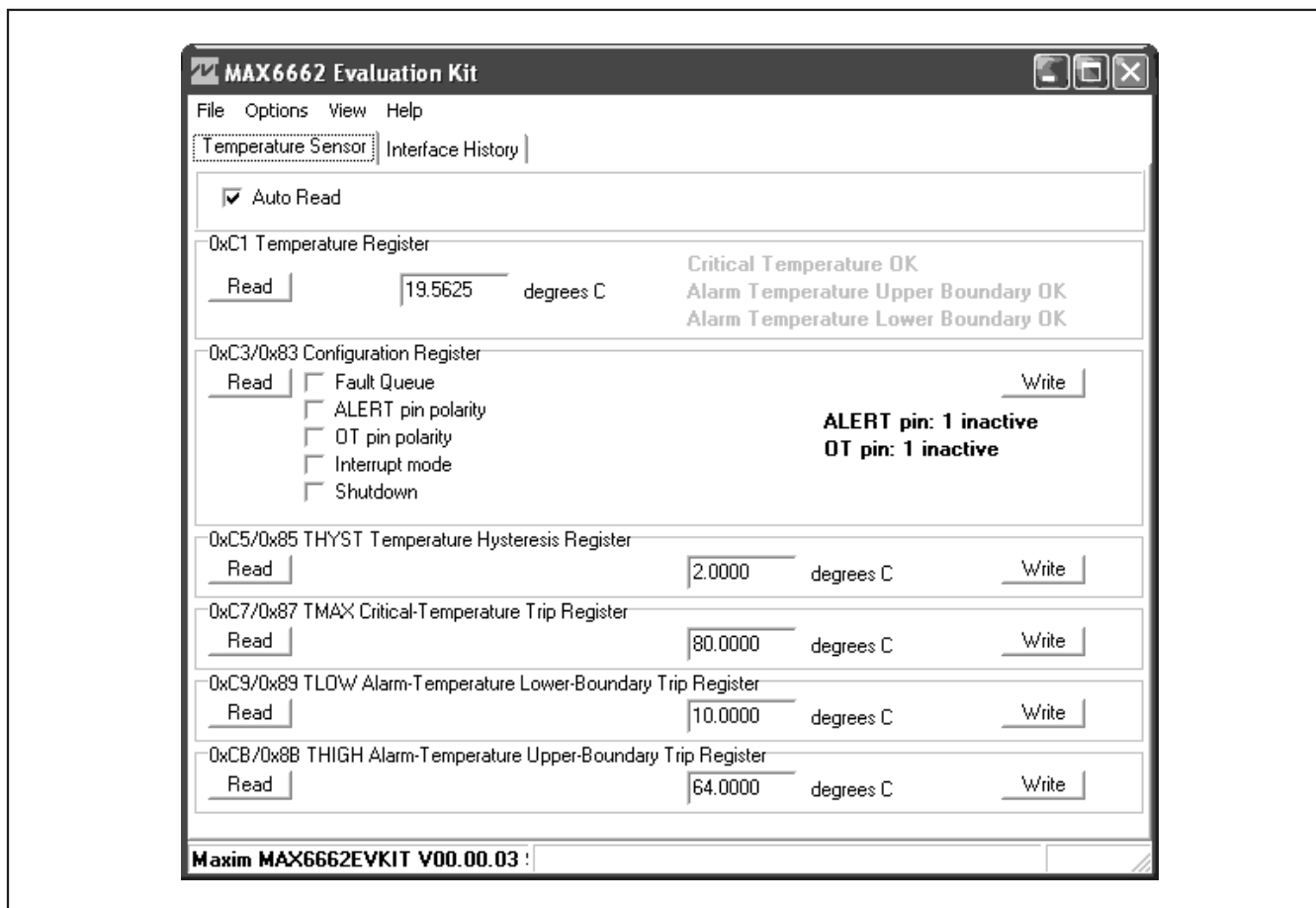

Figure 1. MAX6662 EV Kit Software Main Window (Temperature Sensor Tab)

- 14) Increase the applied heat to the MAX6662 to exceed the programmed critical temperature threshold. The **> Critical Temperature** is highlighted, the OT pin status indicator changes to **OT pin: 0 active**, the OT pin of the MAX6662 goes low, and LED D2 on the evaluation board turns on. The integer part of the temperature must be greater than $T_{CRITICAL}$ to trip the indicators.
- 15) Allow the MAX6662 temperature to gradually drop to room temperature and observe how the limit register alarms change.
- 16) When the temperature drops below 33 degrees centigrade ($T_{CRITICAL} - T_{HYST}$), the critical temperature indicator changes to **Critical Temperature OK** and is grayed out, the OT pin status indicator changes to **OT pin: 1 inactive**, the OT pin of the MAX6662 goes high, and LED D2 on the evaluation board turns off.
- 17) When temperature drops below 28 degrees centigrade ($T_{HIGH} - T_{HYST}$), the alarm indicator changes to **Alarm Temperature Upper Boundary OK** and is grayed out, the ALERT pin status indicator changes to **ALERT pin: 1 inactive**, the ALERT pin of the MAX6662 goes high, and LED D1 on the evaluation board turns off.
- 18) Apply external cooling to the MAX6662, sufficient to cross the programmed T_{LOW} alarm temperature threshold. The **< Alarm Temperature Lower Boundary** is highlighted, the ALERT pin status indicator changes to **ALERT pin: 0 active**, the ALERT pin of the MAX6662 goes low, and LED D1 on the evaluation board turns on.
- 19) Allow the MAX6662 temperature to gradually rise to room temperature and observe how the limit register alarms change.

MAX6662 Evaluation Kit

Evaluates: MAX6662

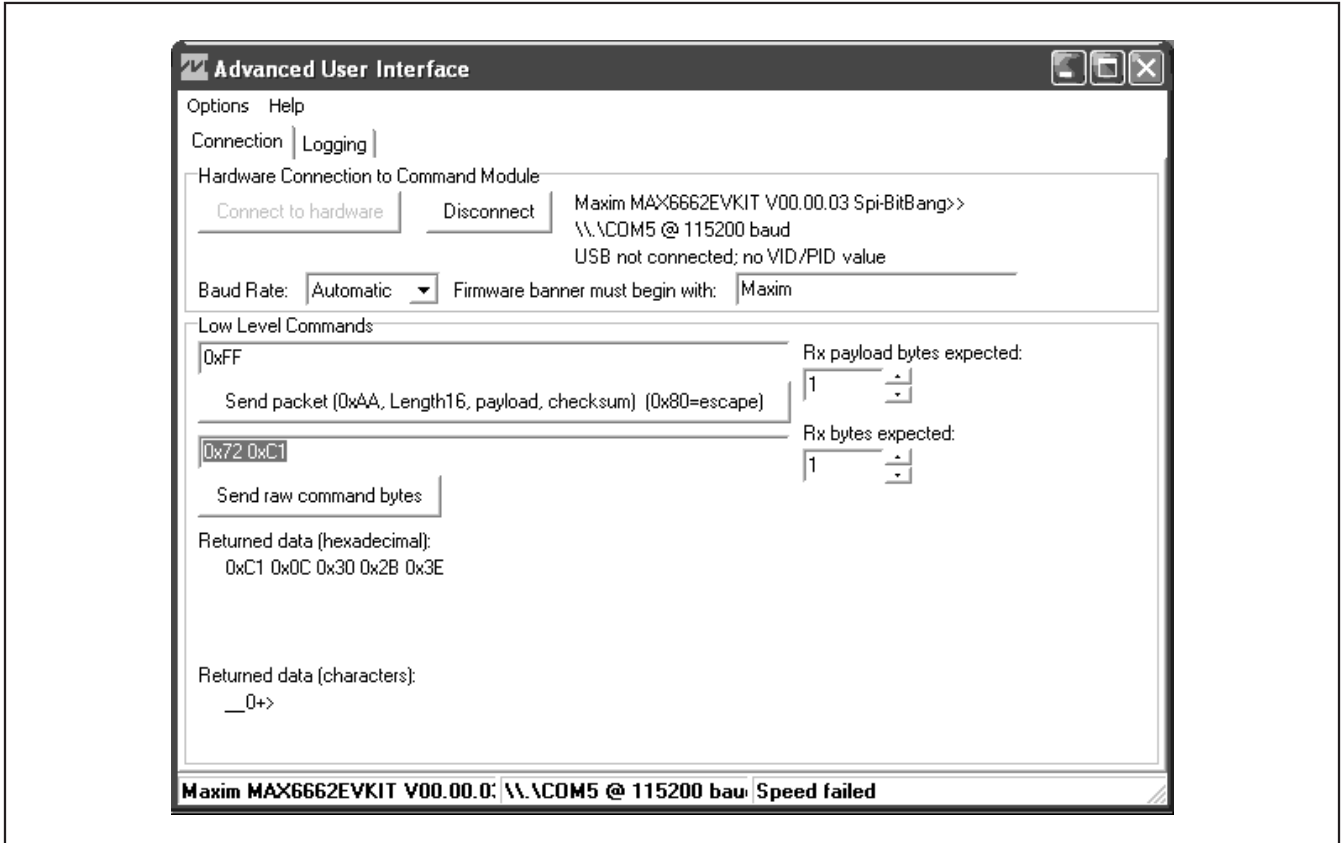

Figure 2. Advanced User Interface Window (2-Wire Interface Tab)

20) When the temperature rises above 18°C ($T_{\text{LOW}} + T_{\text{HYST}} + 1$), the alarm indicator changes to **Alarm Temperature Lower Boundary OK** and is grayed out, the ALERT pin status indicator changes to **ALERT pin: 1 inactive**, the ALERT pin of the MAX6662 goes high, and LED D1 on the evaluation board turns off. The integer part of the temperature must be greater than $(T_{\text{LOW}} + T_{\text{HYST}})$ to trip the indicators.

Detailed Description of Software

The main window of the evaluation software (Figure 1) displays the registers of the MAX6662 temperature sensor. Each register has a **Read** button and each writeable register has a **Write** button. The status of the ALERT and OT output pins are displayed inside the **0xC3/0x83 Configuration Register** group box.

Temperature Sensor Tab

The **Temperature Sensor** tab sheet displays the temperature sensor registers of the MAX6662 (Figure 1).

Each register has a **Read** button and each writeable register has a **Write** button. The **Auto Read** checkbox enables periodic polling of all register values.

Advanced User Interface

A serial interface can be used by advanced users by selecting **Options | Interface (Advanced Users)** from the menu bar. **Note:** The 3-wire interface option is not compatible with the MAX6662 because it has a bidirectional SPI interface. Instead, custom bit-banging firmware commands are used.

Each register's read and write addresses are shown in the title of each register's group box. Read addresses always begin with 0xC and write addresses always begin with 0x8.

For writing registers, click on the **Connection** tab shown in Figure 2. Enter the raw command bytes value of **0x77 0x8B 0x20 0x00** (where 0x8B is the register write address in hexadecimal, and 0x20 0x00 are the data in this example), then press the **Send raw command bytes** button.

MAX6662 Evaluation Kit

For reading registers, click on the **Connection** tab shown in Figure 2. Enter the raw command bytes value of **0x72 0xC1** (where 0xC1 is the register read address in hexadecimal), then press the **Send raw command bytes** button.

Detailed Description of Hardware

The MAX6662 EV kit provides a proven layout for the MAX6662. Easy-to-use USB-PC connection is included on the EV kit. Header H1 provides access to all the active pins of U1. LED D1 lights when $\overline{\text{ALERT}}$ is low, D2 lights when $\overline{\text{OT}}$ is low, and D3 lights to indicate that the board is powered.

MAX6662 Evaluation Kit

Evaluates: MAX6662

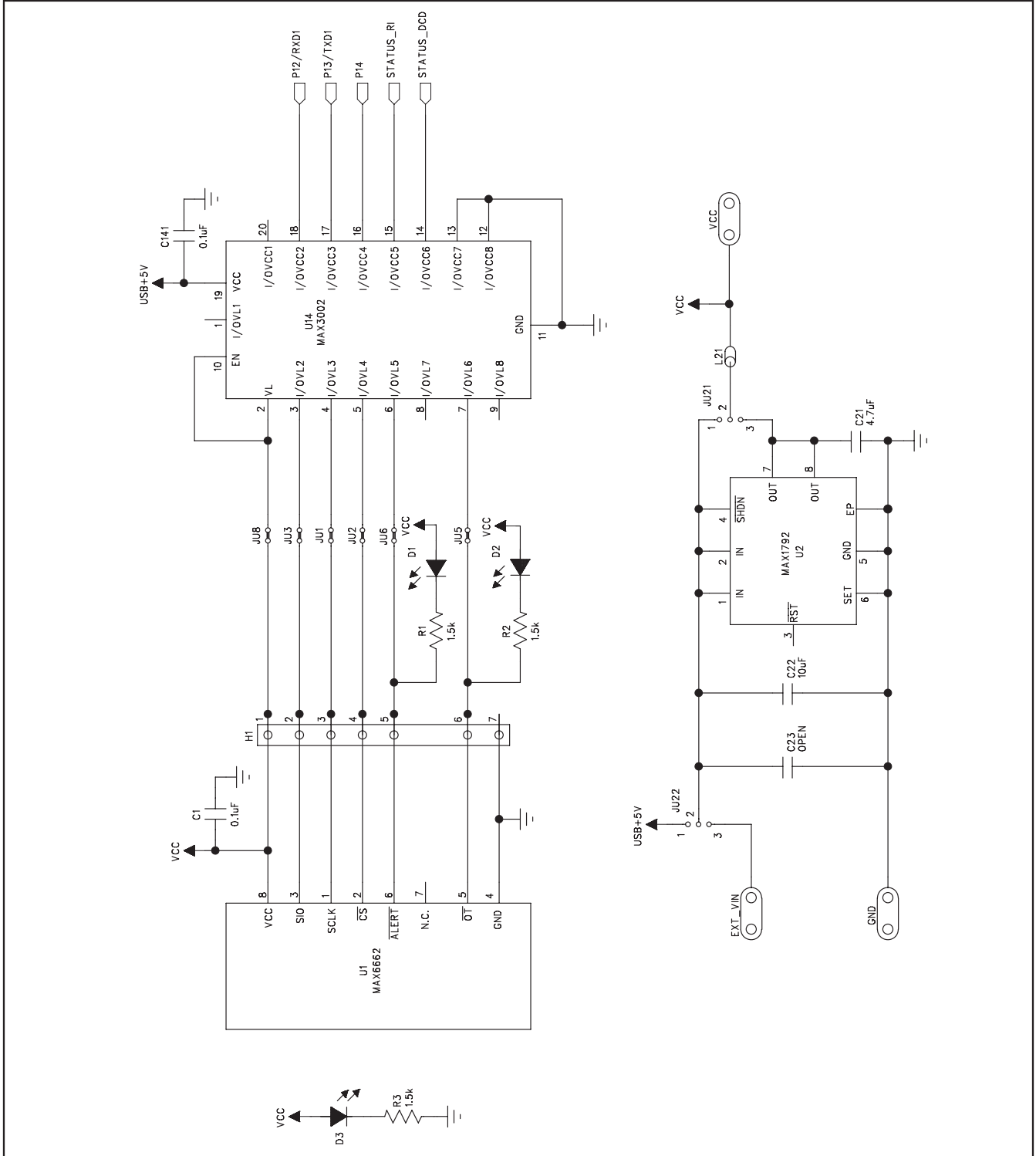

Figure 3a. MAX6662 EV Kit Schematic (Sheet 1 of 3)

MAX6662 Evaluation Kit

Evaluates: MAX6662

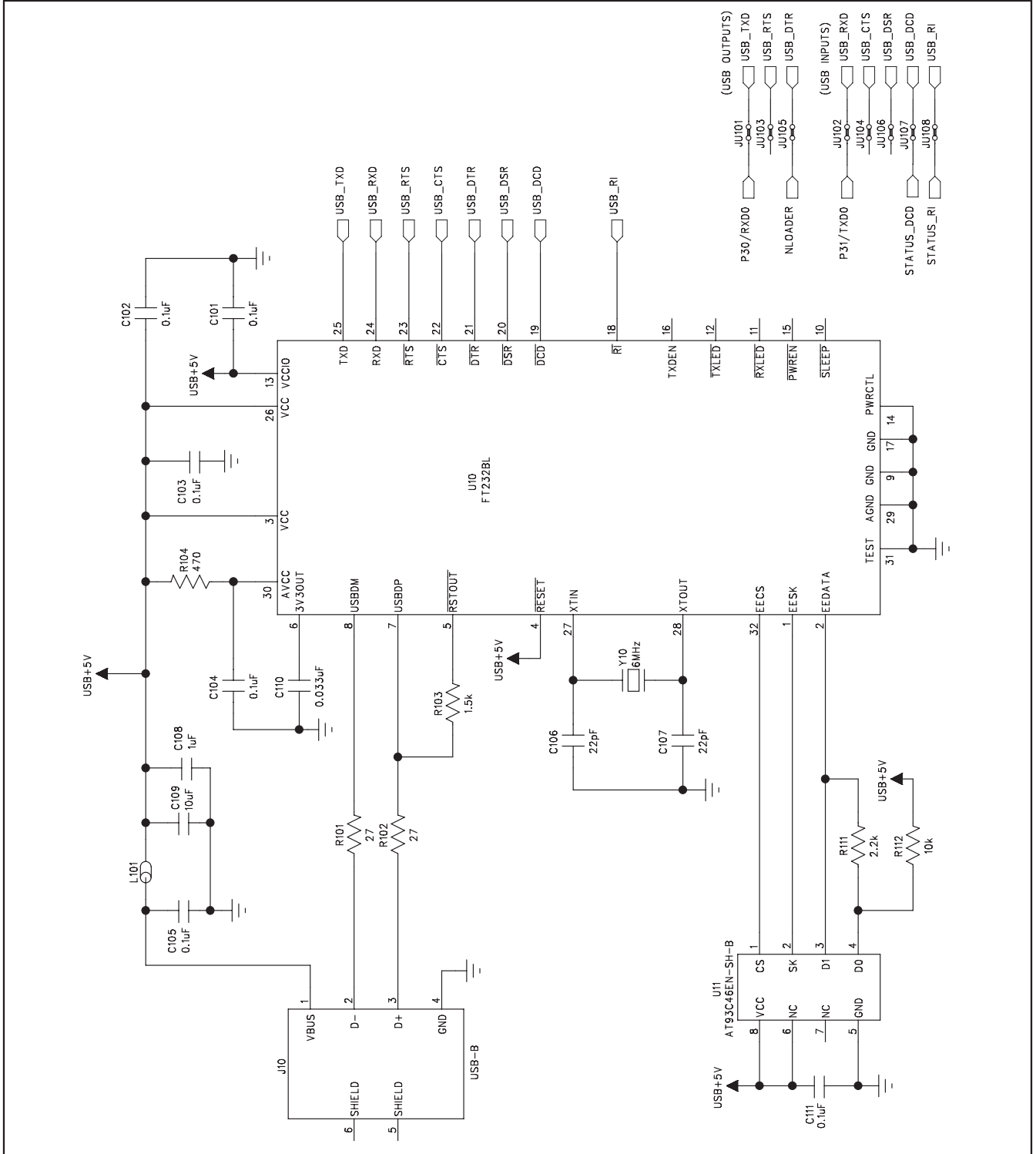

Figure 3c. MAX6662 EV Kit Schematic (Sheet 3 of 3)

MAX6662 Evaluation Kit

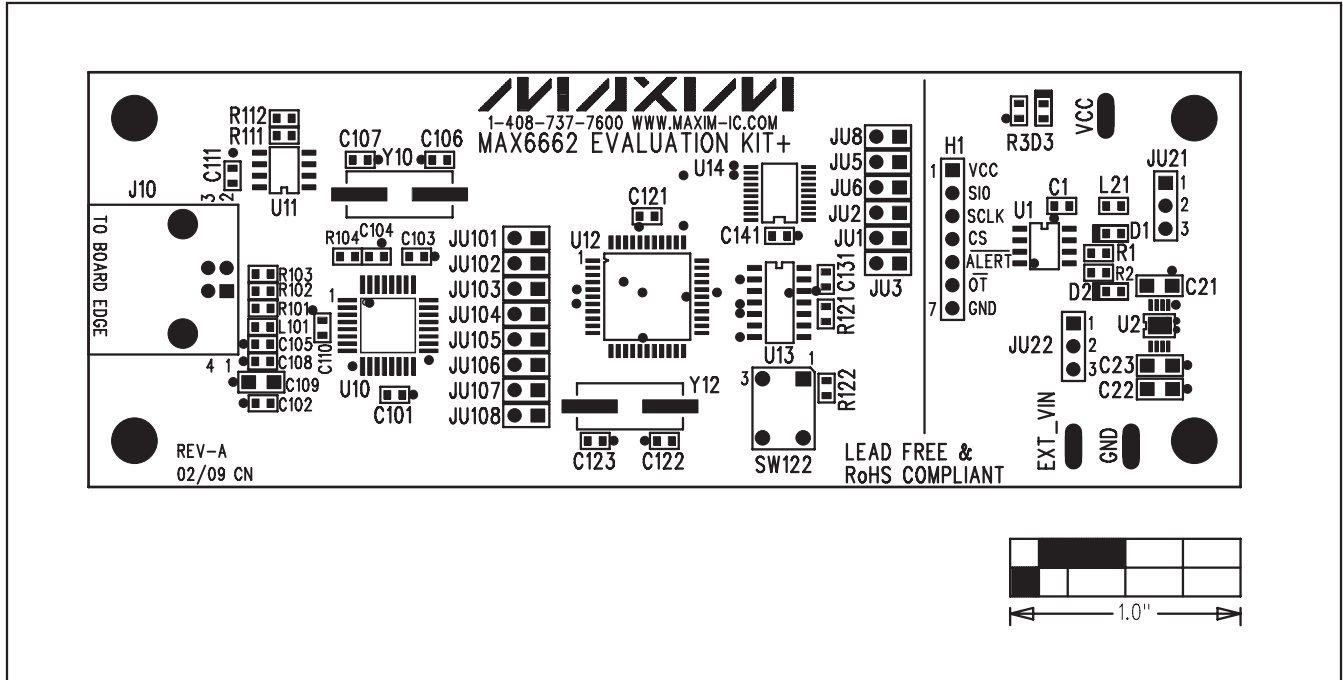

Figure 4. MAX6662 EV Kit Component Placement Guide—Component Side

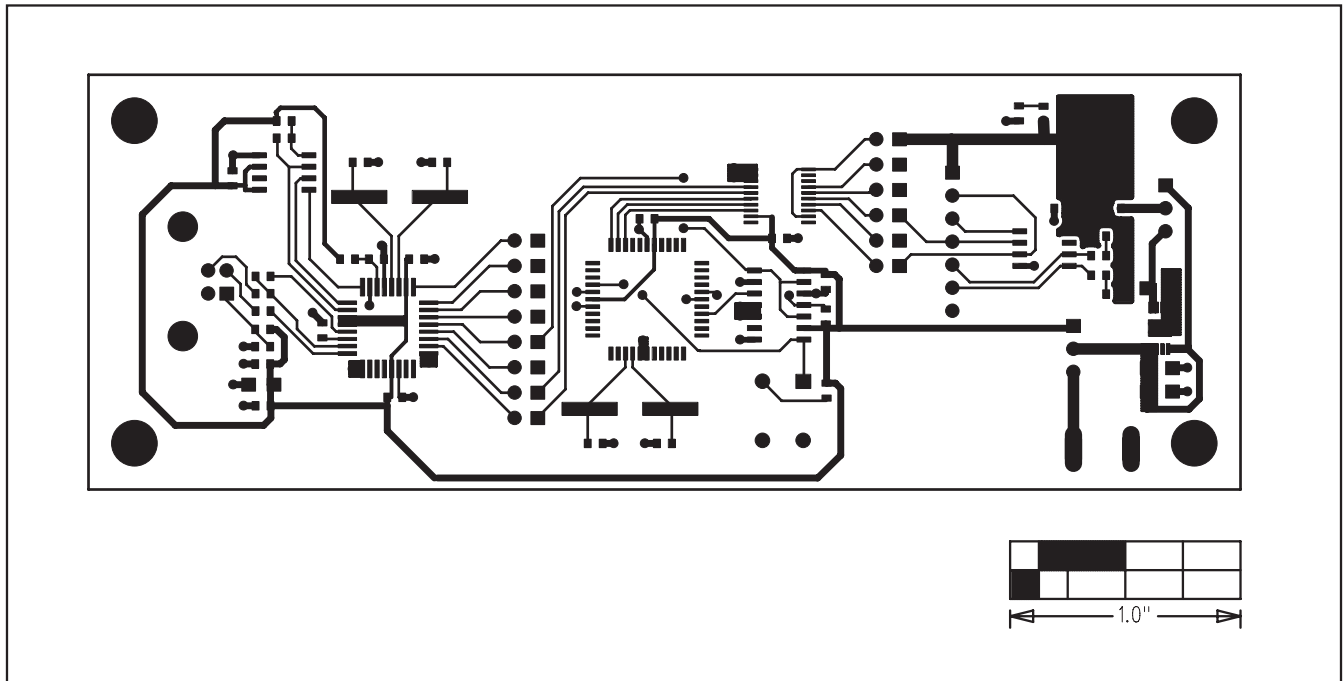

Figure 5. MAX6662 EV Kit PCB Layout—Component Side