

Click [here](#) for production status of specific part numbers.

## MAX77278 Evaluation Kit

Evaluates: MAX77278

### General Description

The MAX77278 evaluation kit (EV kit) is a fully assembled and tested printed circuit board (PCB) that demonstrates the MAX77278. The EV kit allows for easy evaluation of the various MAX77278 resources, including the linear charger, SIMO, linear regulator, analog multiplexer, IR current sink, GPIOs and I<sup>2</sup>C interface.

Windows-based software provides a user-friendly graphical interface (GUI) as well as a detailed register-based interface to exercise the features of the MAX77278.

[Ordering Information](#) appears at end of data sheet.

### Benefits and Features

- Easy to Use
  - GUI Drives I<sup>2</sup>C Interface
  - On-Board Thermistor
  - IR LED
  - GPIO Bank with Push-Buttons
  - Assembled and Fully Tested
- Emulates System Loading
  - On-Board Electronic Load for LDO
  - Electronic Load has Steady-State, Transient, and Random Modes
- Demonstrates End-to-End Analog Multiplexer Implementation
  - On-Board ADC
- Evaluates Both Push-Button and Slider-Switch On-Key Options

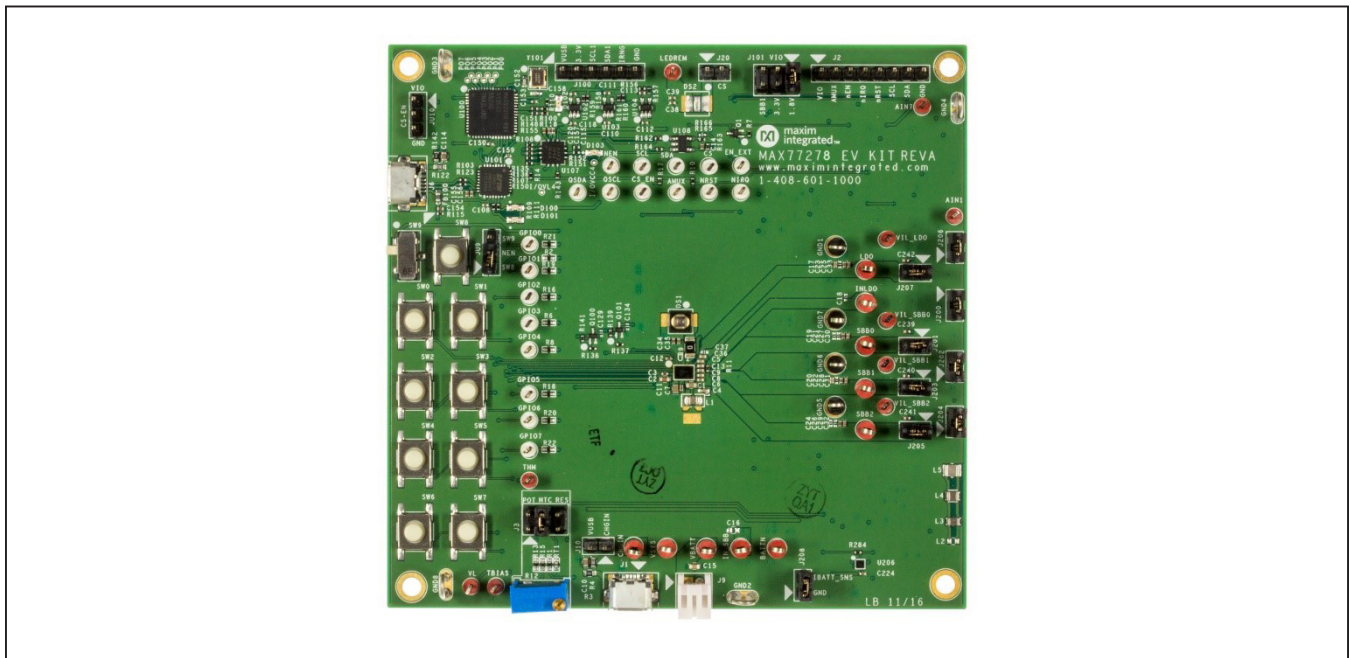

Figure 1. MAX77278 EV Kit Photo

Windows is a registered trademark and registered service mark of Microsoft Corporation.

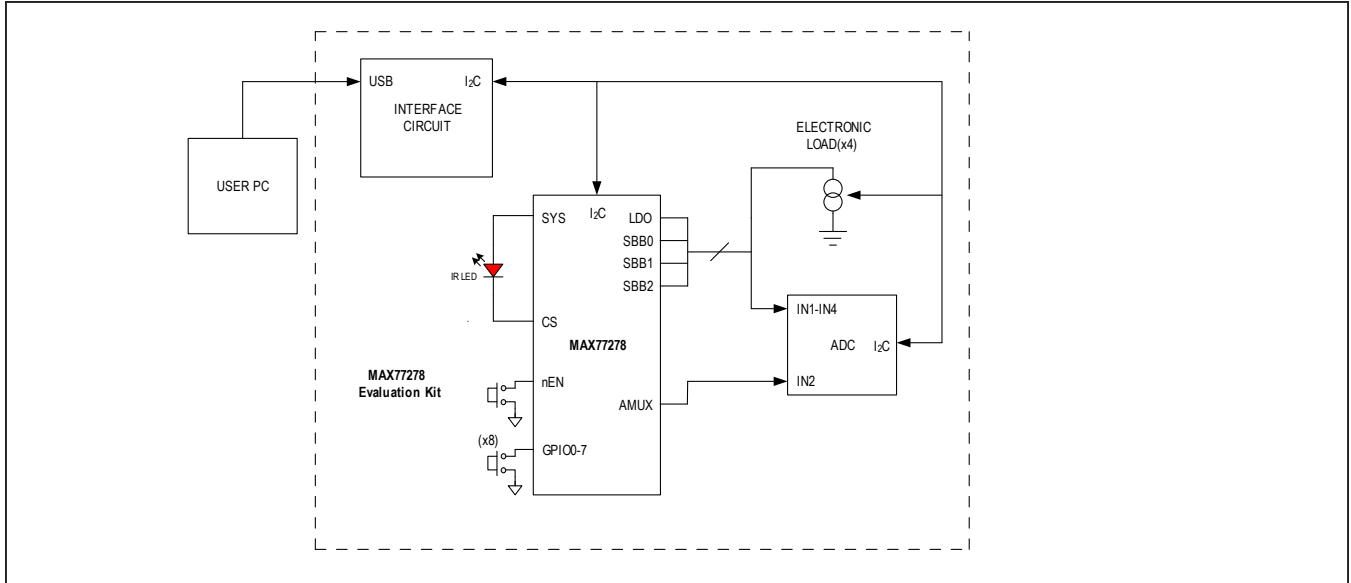

Figure 2. MAX77278 EV Kit Block Diagram

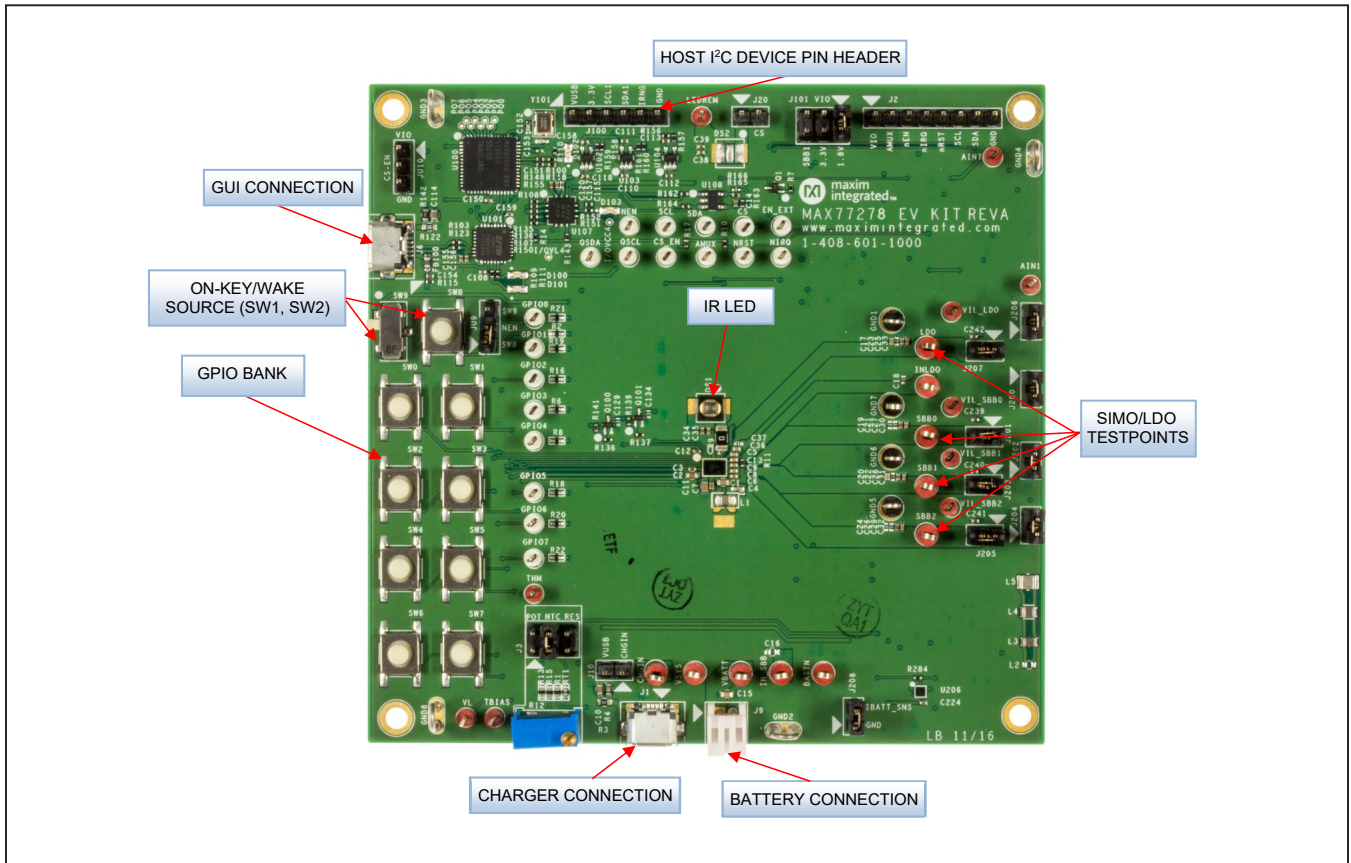

Figure 3. MAX77278 EV Kit Top View

**Table 1. Default Shunt Positions and Jumper Descriptions**

REFERENCE DESIGNATOR	DEFAULT POSITION	FUNCTION
J100	N/A	Do not connect shunts to J100.
J101	1-2	<b>1-2:</b> Connects a VIO to the 1.8V EV kit logic rail. <b>3-4:</b> Connects a VIO to the 3.3V EV kit logic rail. <b>5-6:</b> Connects a VIO to the SBB1 output.
J200	1-2	<b>1-2:</b> Connects the U200 amplifier to the gate of the Q200 load FET.
J201	1-2	<b>1-2:</b> Connects VSBB0 to Load Cell and the on-board ADC.
J202	1-2	<b>1-2:</b> Connects the U201 amplifier to the gate of the Q201 load FET.
J203	1-2	<b>1-2:</b> Connects VSBB1 to Load Cell and the on-board ADC.
J204	1-2	<b>1-2:</b> Connects the U202 amplifier to the gate of the Q202 load FET.
J205	1-2	<b>1-2:</b> Connects VSBB2 to Load Cell and the on-board ADC.
J206	1-2	<b>1-2:</b> Connects the U203 amplifier to the gate of the Q203 load FET.
J207	1-2	<b>1-2:</b> Connects VLDO to Load Cell and the on-board ADC.
J208	1-2	<b>1-2:</b> Bypasses the battery ammeter circuit.
J1	N/A	USB-Micro adapter for powering CHGIN.
J2	N/A	Do not connect shunts to J2.
J3	3-4	<b>1-2:</b> Connects the THM pin to the divider through the potentiometer (R12). <b>3-4:</b> Connects the THM pin to the divider through the on-board thermistor. <b>5-6:</b> Connects the THM pin to the divider through a 10k resistor.
J6	N/A	USB-Micro adapter for GUI communications.
J10	Not Installed	<b>1-2:</b> Connects VUSB to CHGIN. Do not install jumper when CHGIN is powered externally (through a power supply).
J20	N/A	<b>1-2:</b> Connects the remote LED DS2 to the CS pin.
JU9	2-3	<b>1-2:</b> Connects nEN to SW9. <b>2-3:</b> Connects nEN to SW8.
JU10	N/A	<b>1-2:</b> Connects CS_EN to VIO. <b>3-4:</b> Connects CS_EN to GND.

## Quick Start

Follow this procedure to familiarize yourself with the EV kit.

### Required Equipment

- MAX77278 EV kit
- Windows-based PC
- Power supply
- Ammeter
- DVM
- Micro-USB cable
- GUI

**Note:** In the following sections, software-related items are identified by bolding. Text in **bold** refers to items directly from the EV kit software. Text in **bold and underlined** refers to items from the Windows operating system.

### Procedure

- 1) Install GUI software. Visit the product webpage at [www.maximintegrated.com/MAX77278evkit](http://www.maximintegrated.com/MAX77278evkit) and navigate to *Design Resources* to download the latest version of the EV kit software. Save the EV kit software to a temporary folder and decompress the ZIP file.
- 2) Make sure shunts are installed on jumpers per [Table 1](#).
- 3) Apply a 3.7V supply (set for 100mA current limit) through an ammeter (set for 1mA range) across the BATT and GND1 terminals of the EV kit. Turn the supply on.
- 4) Connect a Micro-B USB cable between the EV kit's J6 and your Windows-based PC.
- 5) Open the GUI and press the **Connect** button in the upper left corner. Wait for the device to respond, and in the **Synchronize** window, press the **Read and Close** button.
- 6) Press the on-key (SW8).
- 7) Measure each output voltage with a voltmeter to ensure they are at their nominal values.
- 8) Confirm with the ammeter that the quiescent current is approximately 48 $\mu$ A.
- 9) In the **Global Resources** tab of the GUI, set the 'Main Bias Low-Power Mode' bitfield to '1' (Enabled).
- 10) Confirm with the ammeter that the quiescent current is now approximately 14 $\mu$ A.
- 11) Remove the supply from the BATT. Connect a partially discharged battery (or preloaded power supply) to BATT.
- 12) Make sure that there is no jumper installed at J3. Apply a 5V supply (set for 1A current limit) through an ammeter (set for 1A range) to the CHGIN and GND1 terminals of the EV kit. Turn the supply on.
- 13) In the GUI, set the VFAST\_CHG register to 4.2V, set the IFAST\_CHG register to some current that is safe for your battery (i.e., 30mA for a 45mAh cell). See [Figure 4](#).
- 14) Enable the charger with the CHG\_EN bit.
- 15) Confirm on the ammeter that the charger is sourcing the IFAST\_CHG current to the battery. Note that the current that appears on the ammeter should be the sum of IFAST\_CHG and the standby current of the charger (~1.2 $\mu$ A).

This concludes the Quick Start procedure. Users are now encouraged to explore the device and its register settings with the GUI.

For more information on the GUI, see the [Software](#) section.

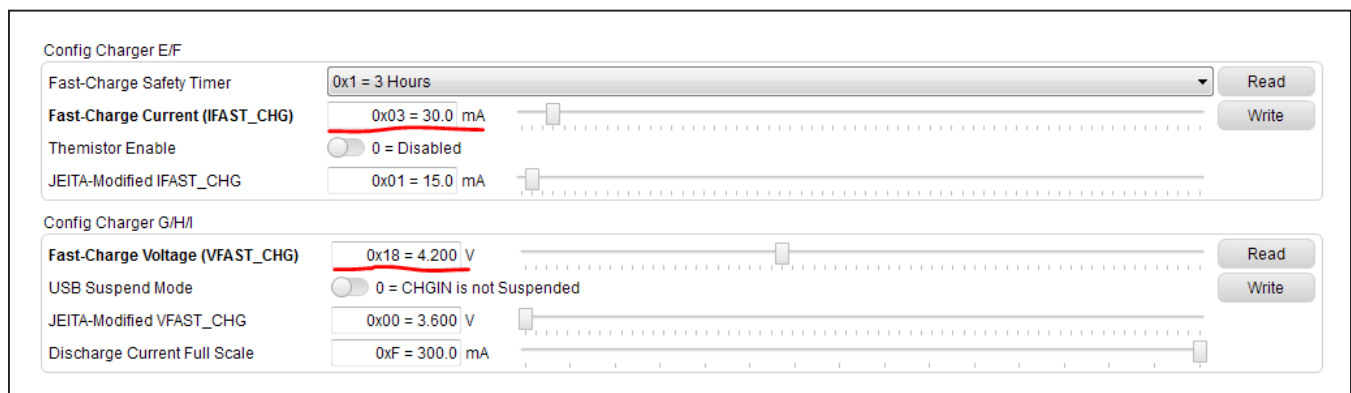

Figure 4. Quick Configuration of the Charger

## EV Kit Features

### On-Key Options

For applications that require the IC to enable with a user-interactable switch, the EV kit comes with two common types: the push-button (momentary) and the slide-switch (persistent). The active-low enable pin (nEN) needs an external pullup to SYS (one has already been installed on the EV kit). Select between either switch with the jumper JU9. Refer to the data sheet for more information on configuring the IC for momentary or persistent switches.

### Temperature Monitoring

Jumper J3 allows selection between the following temperature monitoring options:

- 1) Potentiometer R12 (POT)
- 2) Fixed Resistor Divider R13/R15 (RES)
- 3) 3380K Negative Temperature Coefficient Thermistor RT1 (NTC)

Use the potentiometer setting (POT) to quickly simulate a changing battery temperature to evaluate the charger’s JEITA safe charging response. Turn the potentiometer knob counterclockwise to simulate decreasing battery temperature. Turn the knob clockwise to simulate increasing temperature. Use the resistor setting (RES) to permanently simulate a normal temperature (25°C). Use the thermistor setting (NTC) to evaluate the charger’s response to actual EV kit temperature. The NTC beta parameter is 3380K. Temperature thresholds corresponding to this NTC beta are listed in [Table 2](#). Refer to the data sheet for guidance on how to design with different NTC beta.

The MAX77278 automatically biases the temperature monitoring circuit whenever CHGIN is valid or the MUX\_SEL[3:0] bitfield is connecting the TBIAS or THM pins to the AMUX output. Refer to the *Adjustable Thermistor Temperature Monitors* section of the MAX77278 data sheet for more information.

### Electronic Load

The EV kit comes with four electronic loads that allow the user to easily evaluate each of the DC-DC regulators. An on-board DAC and op-amp configuration set the load current through I<sup>2</sup>C, and J200-J207 connect the loads to the outputs of the SIMO and the LDO. Emulate SYS loading by removing J207 and connecting pin 1 of the header to VSYS with a wire. To exercise the load transient response for any of the regulators, remove the respective MOSFET gate jumper and connect a signal generator to the gate of the load MOSFET (pin 2 of the header).

Drive the MOSFET gate with a signal between ~1V (off) and ~3V (fully on) to apply transients to the output of the regulator. Note that there is a 1Ω sense resistor with test point access (called VIL\_x) that allows for a 1:1 conversion of load current to voltage.

### On-Board ADC (MAX11614)

An on-board ADC is available to convert the voltage at the electronic loads, as well as the AMUX pin of the MAX77278. Use the GUI to convert these voltages to digital information.

**Table 2. Trip Thresholds for 3380K Beta Thermistor**

TRIP VOLTAGE (V)	TRIP TEMPERATURES (°C)
1.024	-10
0.976	-5
0.923	0
0.867	5
0.807	10
0.747	15
0.511	35
0.459	40
0.411	45
0.367	50
0.327	55
0.291	60

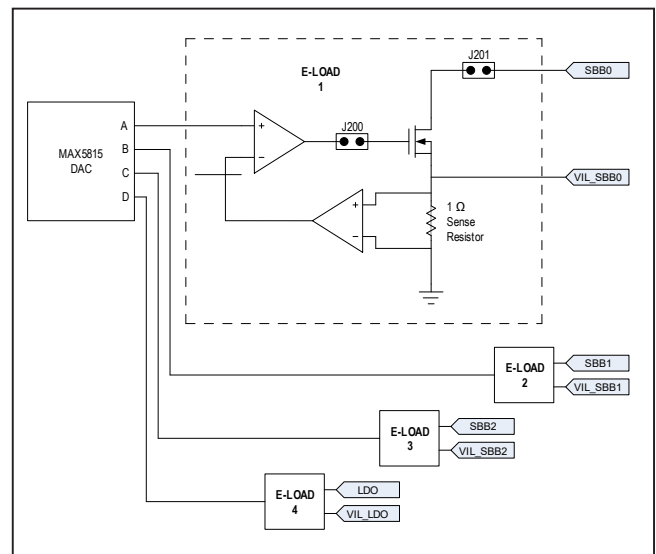

Figure 5. Electronic Load Block Diagram

### Software

The graphical user interface (GUI) software allows for quick, easy, and thorough evaluation of the MAX77278. The GUI is designed to have individual tabs for each functional block of the device (**Global Resources, Interrupts/Status, Charger, LDO, Current Sinks, AMUX/ADC**) and two additional tabs for controlling EV kit hardware (**Load Control, AMUX/ADC**). See [Figure 6](#) for a screenshot of the GUI upon first opening.

### Installation

Visit [www.maximintegrated.com/evkitsoftware](http://www.maximintegrated.com/evkitsoftware) to download the latest version of the EV kit software. Save the EV kit software to a temporary folder and uncompress the ZIP file.

### Windows Drivers

Upon connection of a micro-USB cable between the PC and the EV kit for the first time, wait a few minutes for Windows to automatically install the necessary drivers.

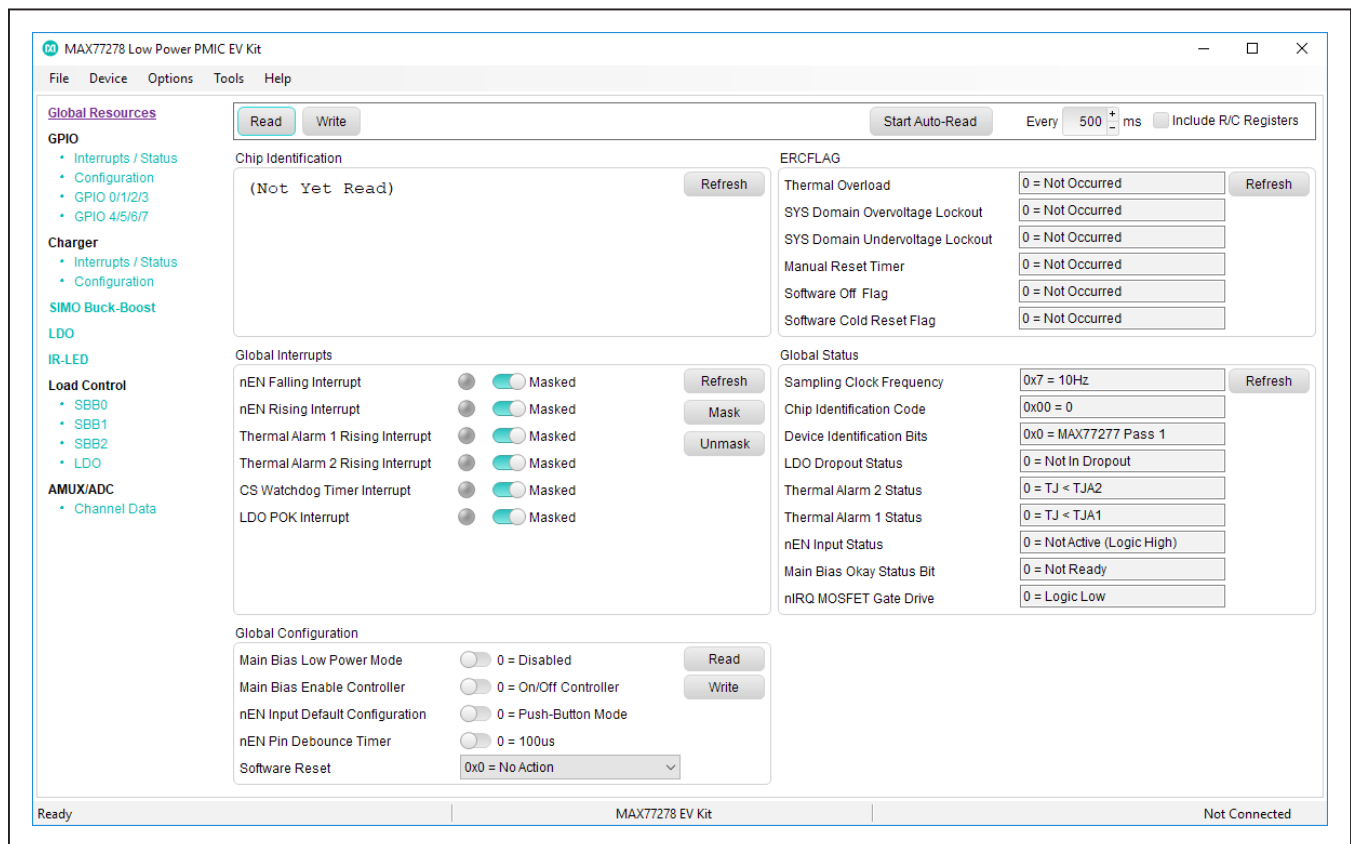

Figure 6. MAX77278 EV Kit GUI Top-Level Interface



### Graphical User Interface (GUI) Details

The GUI drives I<sup>2</sup>C-communication with the EV kit. Every control in the GUI (excluding the **Load Control** and **AMUX/ADC** tabs) corresponds directly to a register within the MAX77278. Refer to the register map in the device data sheet for a complete description of the registers. The **Load Control** and **AMUX/ADC** tabs provide additional functionality with the EV kit.

#### Load Control Tab

The **Load Control** tab contains controls for configuring the electronic loads. The GUI is capable of setting steady-

state, transient, and random load currents. To set a load current, use the slider bar or text field to input a value (mA) and press the **Enable** button. Shuffle through the modes to exercise different load conditions. The offset and gain values are set by Maxim and do not need to be altered.

#### AMUX/ADC Tab

The **AMUX/ADC** tab allows users to convert important voltage and current signals to digital readings. To read a signal, press the **Read** button and examine the 'Interpreted Value' column.

### Ordering Information

PART	TYPE
MAX77278EVKIT#	EV Kit

*#Denotes a RoHS-compliant device that may include lead(Pb) that is exempt under the RoHS requirements.*

MAX77278 EV Kit Bill of Materials

REF_DES	DNI/DNP	QTY	MFG PART #	MANUFACTURER	VALUE	DESCRIPTION
VL, THM, AIN1, AIN7, TBAS, LEDREM, VIL_LDO, VIL_SBB0-VIL_SBB2	-	10	5000	KEystone	N/A	TEST POINT; PIN DIA=0.1IN; TOTAL LENGTH=0.3IN; BOARD HOLE=0.04IN; RED; PHOSPHOR BRONZE WIRE SILVER PLATE FINISH;
CS, NEN, SCL, SDA, AMUX, NIRO, NRST, QSCL, QSDA, CS_EN, GPIO0-GPIO7, EN_EXT	-	19	5002	KEystone	N/A	TEST POINT; PIN DIA=0.1IN; TOTAL LENGTH=0.3IN; BOARD HOLE=0.04IN; WHITE; PHOSPHOR BRONZE WIRE SILVER;
LDO_SBB0-SBB2, VSYS, BATTN, CHGIN, INLDO, VBATT, IN_SBB	-	10	5010	KEystone	N/A	TESTPOINT WITH 1.80MM HOLE DIA, RED, MULTIPURPOSE;
C1, C11, C15	-	3	ANY	ANY	22UF	CAPACITOR; SMT (0603); CERAMIC CHIP; 22UF; 10V; TOL=20%; MODEL=CL SERIES; TG=-55 DEGC TO +85 DEGC; TC=X5R; FORMFACTOR
C2	-	1	C1608XSR1E475K080AC; GRM188R61E475KE11	TDK; MURATA	4.7UF	CAPACITOR; SMT (0603); CERAMIC CHIP; 4.7UF; 25V; TOL=10%; TG=-55 DEGC TO +85 DEGC; TC=X5R
C3, C12, C34, C38, C110-C113, C115, C118, C120, C158, C239-C242	-	16	ANY	ANY	1UF	CAPACITOR; SMT (0402); CERAMIC CHIP; 1UF; 6.3V; TOL=20%; MODEL=C SERIES; TG=-55 DEGC TO +85 DEGC; TC=X5R; FORMFACTOR
C4	-	1	C1005XSR1H332K050	TDK	3300PF	CAPACITOR; SMT (0402); CERAMIC CHIP; 3300PF; 50V; TOL=10%; TG=-55 DEGC TO +85 DEGC; TC=X5R
C5, C6, C8, C9, C13, C17, C20, C36	-	8	ANY	ANY	10UF	CAPACITOR; SMT (0402); CERAMIC CHIP; 10UF; 6.3V; TOL=20%; MODEL=-; TG=-55 DEGC TO +85 DEGC; TC=X5R; FORMFACTOR
C7, C154	-	2	ANY	ANY	4.7UF	CAPACITOR; SMT (0402); CERAMIC CHIP; 4.7UF; 10V; TOL=20%; MODEL=C SERIES; TG=-55 DEGC TO +85 DEGC; TC=X5R; FORMFACTOR
C10, C114	-	2	ANY	ANY	0.47UF	CAPACITOR; SMT; 0603; CERAMIC; 0.47uF; 10V; 10%; X5R; -55degC to +125degC; FORMFACTOR
C14, C108, C150, C151, C155-C157, C159, C202, C207, C212, C217, C221-C224, C226, C229, C234-C237, C244	-	23	ANY	ANY	0.1UF	CAPACITOR; SMT (0402); CERAMIC CHIP; 0.1UF; 25V; TOL=10%; MODEL=C SERIES; TG=-55 DEGC TO +125 DEGC; TC=X7R; FORMFACTOR
C25, C27-C29	-	4	ANY	ANY	0.1UF	CAPACITOR; SMT; 0402; CERAMIC; 0.1uF; 10V; 10%; X5R; -55degC to +125degC; 0 +/-30PPM/degC; FORMFACTOR ;
C30-C33	-	4	ANY	ANY	0.01UF	CAPACITOR; SMT (0402); CERAMIC CHIP; 0.01UF; 10V; TOL=10%; MODEL=C0402C SERIES; TG=-55 DEGC TO +125 DEGC; TC=X7R
C35, C39	-	2	GRM155R601104KA01; C0402C104K9PAC	MURATA; KEMET	0.1UF	CAPACITOR; SMT (0402); CERAMIC CHIP; 0.1UF; 6.3V; TOL=10%; TG=-55 DEGC TO +85 DEGC; TC=X5R
C152, C153	-	2	GRM1555C1H150FA01	MURATA	15PF	CAPACITOR; SMT (0402); CERAMIC CHIP; 15PF; 50V; TOL=1%; TG=-55 DEGC TO +125 DEGC; TC=COG
C200, C205, C210, C215, C220, C238, C248-C252	-	11	C1005XSR1H472K050	TDK	4700PF	CAPACITOR; SMT (0402); CERAMIC CHIP; 4700PF; 50V; TOL=10%; TG=-55 DEGC TO +85 DEGC; TC=X5R
C201, C206, C211, C216	-	4	ANY	ANY	1000PF	CAPACITOR; SMT (0402); CERAMIC CHIP; 1000PF; 50V; TOL=10%; MODEL=COG; TG=-55 DEGC TO +125 DEGC; TC=+; FORMFACTOR
C203, C204, C208, C209, C213, C214, C218, C219	-	8	C0402C180J5GAC; GRM1555C1H180JA01JC1005COG1H180J050	KEMET/MURATA/TKD	18PF	CAPACITOR; SMT (0402); CERAMIC CHIP; 18PF; 50V; TOL=5%; TG=-55 DEGC TO +125 DEGC; TC=COG
C225	-	1	GRM1555C1H331GA01; C1005COG1H331G050	MURATA/TKD	330PF	CAPACITOR; SMT (0402); CERAMIC CHIP; 330PF; 50V; TOL=2%; TG=-55 DEGC TO +125 DEGC; TC=COG
C227	-	1	GRM1555C1H181GA01	MURATA	180PF	CAPACITOR; SMT (0402); CERAMIC CHIP; 180PF; 50V; TOL=2%; TG=-55 DEGC TO +125 DEGC; TC=COG
C228	-	1	ANY	ANY	1UF	CAPACITOR; SMT (0402); CERAMIC CHIP; 1UF; 10V; TOL=10%; MODEL=-; TG=-55 DEGC TO +85 DEGC; TC=X5R; FORMFACTOR
D100, D101	-	2	LTST-C190YKT	LITE-ON ELECTRONICS, INC.	LTST-C190YKT	DIODE; LED; STANDARD; YELLOW; SMT (0603); PIV=5.0V; IF=0.02A; -55 DEGC TO +85 DEGC
D102, D103	-	2	LTST-C190CKT	LITE-ON ELECTRONICS, INC.	LTST-C190CKT	DIODE; LED; STANDARD; RED; SMT (0603); PIV=5.0V; IF=0.04A; -55 DEGC TO +85 DEGC
DS1, DS2	-	2	Q65111A2364	OSRAM	Q65111A2364	DIODE; LED; OSRON BLACK 850NM; BLACK; SMT; VF=1.5V; IF=1A
FB100	-	1	BLM18PG221SN1	MURATA	220	INDUCTOR; SMT (0603); FERRITE-BEAD; 220; TOL=+/-25%; 1.4A; -55 DEGC TO +125 DEGC
GND1, GND5-GND7	-	4	5011	KEystone	N/A	TEST POINT; PIN DIA=0.125IN; TOTAL LENGTH=0.445IN; BOARD HOLE=0.063IN; BLACK; PHOSPHOR BRONZE WIRE SILVER PLATE FINISH;
GND2-GND4, GND8	-	4	9020 BUSS	WEICO WIRE	MAXIMPAD	EVK KIT PARTS; MAXIM PAD; WIRE; NATURAL; SOLID; WEICO WIRE; SOFT DRAWN BUS TYPE-S; 20AWG
J1, J6	-	2	10103592-0001LF	FCI CONNECT	10103592-0001LF	CONNECTOR; FEMALE; SMT; MICRO USB B-TYPE REVERSE; RIGHT ANGLE; 5PINS
J2	-	1	PBC08SAAN	SULLINS ELECTRONICS CORP.	PBC08SAAN	CONNECTOR; MALE; THROUGH HOLE; BREAKAWAY; STRAIGHT; 8PINS; -65 DEGC TO +125 DEGC
J3, J101	-	2	TSW-102-26-T-T	SAMTEC	TSW-102-26-T-T	CONNECTOR; THROUGH HOLE; TSW SERIES; TRIPLE ROW; STRAIGHT; 6PINS
J4, J5, J200-J208	-	11	TSW-102-07-T-S	SAMTEC	TSW-102-07-T-S	CONNECTOR; THROUGH HOLE; TSW SERIES; SINGLE ROW; STRAIGHT; 2PINS; -55 DEGC TO +105 DEGC
J7, J8	-	2	TSW-103-07-T-S	SAMTEC	TSW-103-07-T-S	CONNECTOR; THROUGH HOLE; TSW SERIES; SINGLE ROW; STRAIGHT; 3PINS
J9	-	1	S2B-PH-K-S(LF)(SN)	JST MANUFACTURING	S2B-PH-K-S(LF)(SN)	CONNECTOR; MALE; THROUGH HOLE; 2.0MM PITCH; DISCONNECTABLE CRIMP STYLE CONNECTOR; SIDE ENTRY TYPE; RIGHT ANGLE; 2PINS
J100	-	1	PBC06SAAN	SULLINS ELECTRONICS CORP.	PBC06SAAN	CONNECTOR; MALE; THROUGH HOLE; BREAKAWAY; STRAIGHT; 6PINS; -65 DEGC TO +125 DEGC
L1	-	1	DFE201210U-1R5M=P2	TOKO	1.5UH	EVKIT PART-INDUCTOR; SMT (0805); METAL ALLOY CHIP; 1.5UH; TOL=+/-20%; 1.9A; 2.00MMX1.20MMX1.00MM
L3	-	1	CIGT201208EH2R2MN	SAMSUNG ELECTRONICS	2.2UH	EVKIT PART-INDUCTOR; SMT (0805); METAL COMPOSITE CORE; 2.2UH; TOL=+/-20%; 1.8A; 2.00MMX1.25MMX0.80MM
L4	-	1	CIGT201610EH2R2MN	SAMSUNG ELECTRONICS	2.2UH	EVKIT PART-INDUCTOR; SMT (0806); METAL COMPOSITE CORE; 2.2UH; TOL=+/-20%; 2.7A; 2.00MMX1.60MMX1.00MM
L5	-	1	DFE252007F-2R2M=P2	MURATA	2.2UH	EVKIT PART-INDUCTOR; SMT (1008); METAL ALLOY CHIP; 2.2UH; TOL=+/-20%; 1.7A; 2.50MMX2.00MMX0.70MM
Q1, Q100, Q101	-	3	FDY300NZ	FAIRCHILD SEMICONDUCTOR	FDY300NZ	TRAN; SINGLE N-CHANNEL 2.5V SPECIFIED POWERTRENCH MOSFET; NCH; SC89; PD-(0.625W); I-(0.6A); V-(20V)
Q200-Q203	-	4	IRFHM8337TRPBF	INTERNATIONAL RECTIFIER	IRFHM8337TRPBF	TRAN; HEXFET POWER MOSFET; NCH; POFN8; PD-(2.8W); I-(1.8A); V-(30V)
Q204	-	1	DMG3420U	DIODES INCORPORATED	DMG3420U	TRAN; N-CHANNEL ENHANCEMENT MODE MOSFET; NCH; SOT-23; PD-(0.74W); I-(5.47A); V-(20V)
Q205	-	1	FDN360P	FAIRCHILD SEMICONDUCTOR	FDN360P	TRANSISTOR, MOSFET P-CHANNEL, SUPERSOT-3, PD=0.5W, ID=2.0A, VDS=30V, VGS=+/-20V
Q206	-	1	2N7002	GENERIC PART	2N7002	TRAN; ; NCH; SOT-23; PD-(0.33W); IC-(0.5A); VCEO-(60V); -55 DEGC TO +150 DEGC
R1, R2, R13, R15, R281, R282, R287, R288	-	8	CRCW040210K0FK; RC0402FR-0710K	VISHAY DALE; YAGEO PHICOMP	10K	RESISTOR; 0402; 10K; 1%; 100PPM; 0.0625W; THICK FILM



MAX77278 EV Kit Bill of Materials (continued)

REF. DES	DNI/DNP	QTY	MFG PART #	MANUFACTURER	VALUE	DESCRIPTION
R3, R5, R142, R277, R279	-	5	ANY	ANY	0	RESISTOR; 0603; 0 OHM; 0%; JUMPER; 0.10W; THICK FILM; FORMFACTOR
R4, R122	-	2	ANY	ANY	1M	RESISTOR; 0603; 1M; 1%; 100PPM; 0.10W; THICK FILM; FORMFACTOR
R9	-	1	CRCW12060000ZS; ERJ-8GEY0R00V	VISHAY DALE/PANASONIC	0	RESISTOR; 1206; 0 OHM; 0%; JUMPER; 0.25W; THICK FILM
R10, R14, R293, R295, R297, R299	-	6	ERJ-2RKF4703X	PANASONIC	470K	RESISTOR, 0402, 470K OHM, 1%, 100PPM, 0.0625W, THICK FILM
R11, R17, R135, R136, R139, R141, R143, R148, R152, R155, R162-R164, R166, R204, R212, R225, R227, R238, R246, R251, R259, R285, R286, R302-R308	-	31	ANY	ANY	0	RESISTOR; 0402; 0 OHM; 1%; 100PPM; 0.0625W; THICK FILM; FORMFACTOR
R12	-	1	3296Y-1-204LF	BOURNS	200K	RESISTOR; THROUGH HOLE-RADIAL LEAD; 3296 SERIES; 200K OHM; 10%; 100PPM; 0.5W
R100, R118	-	2	ANY	ANY	4.7K	RESISTOR, 0402, 4.7K OHM, 1%, 100PPM, 0.0625W, THICK FILM; FORMFACTOR
R103, R123, R150	-	3	ANY	ANY	22	RESISTOR, 0402, 22 OHM, 1%, 100PPM, 0.0625W, THICK FILM; FORMFACTOR
R107, R108	-	2	ANY	ANY	2.2K	RESISTOR, 0402, 2.2K OHM, 1%, 100PPM, 0.0625W, THICK FILM; FORMFACTOR
R23, R201, R222, R235, R248, R109, R111	-	7	ANY	ANY	100	RESISTOR, 0402; 100 OHM; 1%; 100PPM; 0.0625W; THICK FILM; FORMFACTOR
R110	-	1	CRCW0402470RFB	VISHAY DALE	470	RESISTOR, 0402, 470 OHM, 1%, 100PPM, 0.0625W, THICK FILM
R6-R8, R16, R18-R22, R284, R115, R157, R159, R161, R214, R280, R283	-	17	ANY	ANY	100K	RESISTOR; 0402; 100K; 1%; 100PPM; 0.0625W; THICK FILM; FORMFACTOR
R137, R138	-	2	ANY	ANY	49.9	RESISTOR; 0402; 49.9 OHM; 1%; 100PPM; 0.0625W; THICK FILM; FORMFACTOR
R151	-	1	CRCW0402150RFB; 9C04021A1500FL	VISHAY DALE	150	RESISTOR; 0402; 150 OHM; 1%; 100PPM; 0.0625W; THICK FILM
R156	-	1	CRCW0402105KFB	VISHAY DALE	105K	RESISTOR; 0402; 105K OHM; 1%; 100PPM; 0.063W ; THICK FILM
R158	-	1	CRCW0402169KFB	VISHAY DALE	169K	RESISTOR; 0402; 169K OHM; 1%; 100PPM; 0.063W; THICK FILM
R160	-	1	CRCW04024752FK; 9C04021A4752FLHF3; CRCW040247K5FK	VISHAY DALE	47.5K	RESISTOR; 0402; 47.5K; 1%; 100PPM; 0.0625W; THICK FILM
R202, R223, R236, R249	-	4	CRCW0402680RFB; RC0402FR-07680RL	VISHAY DALE/YAGEO PHICOMP	680	RESISTOR, 0402, 680 OHM, 1%, 100PPM, 0.0625W, THICK FILM
R203, R224, R237, R250	-	4	CRCW040220K0FB	VISHAY DALE	20K	RESISTOR; 0402; 20K OHM; 1%; 100PPM; 0.063W; THICK FILM
R205, R206, R226, R228, R239, R240, R252, R253	-	8	CRCW04024991FB	VISHAY DALE	4.99K	RESISTOR; 0402; 4.99K; 1%; 100PPM; 0.0625W; THICK FILM
R210, R231, R244, R257, R301	-	5	CRCW04021M00FB	VISHAY DALE	1M	RESISTOR; 0402; 1M; 1%; 100PPM; 0.0625W; THICK FILM
R211, R233, R245, R258	-	4	ERJ-3RQF1R0V	PANASONIC	1	RESISTOR, 0603, 1 OHM, 1%, 100PPM, 0.10W, THICK FILM
R261	-	1	CSR0603FR100	STACKPOLE ELECTRONICS INC	0.1	RESISTOR; 0603; 0.1 OHM; 1%; 300PPM; 0.125W; THICK FILM
R262	-	1	CRCW060310R0FB; MCR03E2PFX10R0	VISHAY DALE/ROHM	10	RESISTOR; 0603; 10 OHM; 1%; 100PPM; 0.10W; THICK FILM
R265-R268	-	4	CRCW040264K9FB	VISHAY DALE	64.9K	RESISTOR; 0402; 64.9K OHM; 1%; 100PPM; 0.063W; METAL FILM
R207, R208, R229, R230, R242, R243, R254, R255, R263, R264, R269	-	11	CRCW04021K00FB; RC0402FR-071KL	VISHAYDALE;YAGEOPHICOMP	1K	RESISTOR;0402;1K;1%;100PPM;0.0625W;THICKFILM
R271-R274	-	4	CRCW040210M0FB	VISHAY DALE	10M	RESISTOR, 0402, 10M OHM, 1%, 100PPM, 0.0625W, THICK FILM
R294, R296, R298, R300	-	4	CRCW0402649KFB	VISHAY DALE	649K	RESISTOR; 0402; 649K OHM; 1%; 100PPM; 0.063W; THICK FILM
RT1	-	1	NCP15XH103F03RC	MURATA	10K	THERMISTOR; SMT (0402); THICK FILM (NICKEL PLATED); 10K; TOL=+/-1%
SW0-SW8	-	9	EVQ-Q2K03W	PANASONIC	EVQ-Q2K03W	SWITCH; SPST; SMT; 15V; 0.02A; LIGHT TOUCH SWITCH; RCOIL= OHM; RINSULATION= OHM; PANASONIC
SW9	-	1	CL-SB-12B-11	NIDEC COPAL ELECTRONICS CORP	CL-SB-12B-11	SWITCH; SPDT; SMT; 12V; 0.02A; CL-SB SERIES; SLIDE SWITCH; RCOIL=0.05 OHM; RINSULATION=100M OHM; NIDEC COPAL ELECTRONICS CORP
U1	-	1	MAX77278EWB+	MAXIM	MAX77278EWB+	EVKIT PART - IC; LOW POWER PMIC FOR WEARABLE AND HANDHELD DEVICES; PACKAGE OUTLINE: 21-100152; PACKAGE CODE: W352C3+1; WLP35
U100	-	1	MAXQ2000-RBX+	MAXIM	MAXQ2000-RBX+	IC; CTRL; LOW-POWER LCD MICROCONTROLLER; TQFN56-EP 8X8
U101	-	1	FT232RQ	FUTURE TECHNOLOGY DEVICES INTL	FT232RQ	IC; INFC; UART INTERFACE IC USB TO SERIAL; QFN32-EP 5X5
U102-U104	-	3	MAX8512EXK+	MAXIM	MAX8512EXK	IC; VREG; Ultra-Low-Noise, High PSRR, Adjustable Vout, SC70-5
U107	-	1	MAX3395EETC+	MAXIM	MAX3395EETC	IC; TRANS; 15KV ESD-PROTECTED HIGH-DRIVE CURRENT QUAD-LEVEL TRANSLATOR WITH SPEED-UP CIRCUITRY; TQFN12 4X4
U108	-	1	24AA02T-I/OT	MICROCHIP	24AA02T-I/OT	IC; EPROM; 2K 1ZC SERIAL EEPROM; SOT23-5
U200-U204	-	5	MAX44251AUA+	MAXIM	MAX44251AUA+	IC; OPAMP; ULTRA-PRECISION; LOW-NOISE OP AMP; UMAX8
U205	-	1	MAX5815AAUD+	MAXIM	MAX5815AAUD+	IC; DAC; ULTRA-SMALL; QUAD-CHANNEL; 12-BIT BUFFERED OUTPUT DAC WITH INTERNAL REFERENCE AND I2C INTERFACE; TSSOP14
U206	-	1	MAX14689EWL+	MAXIM	MAX14689EWL+	IC; ASW; 0.125A; FREQUENCY-SELECTABLE; SWITCHED-CAPACITOR VOLTAGE CONVERTER; WLP9 1.2X1.2
U207	-	1	MAX4238AUT+	MAXIM	MAX4238AUT+	IC; OPAMP; IC; ULTRA-LOW OFFSET/DRIFT; LOW-NOISE; PRECISION SOT23 AMPLIFIER; SOT23-6
U209	-	1	MAX11614EEE+	MAXIM	MAX11614EEE+	IC; ADC; LOW-POWER; 8-CHANNEL; I2C; 12-BIT ADC IN ULTRA-SMALL PACKAGE; QSOP16
U210	-	1	MAX6037BAUK41+	MAXIM	MAX6037BAUK41+	IC; VREF; LOW-POWER; FIXED; ADJUSTABLE REFERENCE WITH SHUTDOWN; SOT23-5
Y101	-	1	CX3225SB16000D0FLIZ	KYOCERA-KINSEKI	16MHZ	CRYSTAL; SMT (3225) 3.2X2.5; 8PF; 16MHZ; +/-10PPM; +/-15PPM
PCB	-	1	MAX77278_SOLDERDOWN_REVA	MAXIM		PCB; PCB:MAX77278_SOLDERDOWN_REVA
L2	DNP	0	MLP1608VR47D	TDK	0.47UH	INDUCTOR; SMT (0603); SHIELDED; 0.47UH; TOL=+/-0.3nH; 0.8A
C16	DNP	0	N/A	N/A	OPEN	CAPACITOR; SMT (0603); OPEN; FORMFACTOR
C18, C19, C21-C24, C26, C37, C129, C134	DNP	0	N/A	N/A	OPEN	CAPACITOR; SMT (0402); OPEN; FORMFACTOR
R165, R213, R234, R247, R260	DNP	0	N/A	N/A	OPEN	RESISTOR; 0402; OPEN; FORMFACTOR

NOTE: DNI--> DO NOT INSTALL (PACKOUT); DNP--> DO NOT PROCURE

**MAX77278 EV Kit Schematic**

Part Number	Configuration	7-bit	8-bit Write	8-bit Read
MAX77278 (PMIC)	ADDR OTP bit set for 0	0x40 0b100 0000	0x80 0b1000 0000	0x81 0b1000 0001
MAX77278 (PMIC)	ADDR OTP bit set for 1	0x48 0b100 1000	0x90 0b1001 0000	0x91 0b1001 0001
MAX77278 (PMIC)	Maxim internal test mode	0x49 0b100 1001	0x92 0b1001 0010	0x93 0b1001 0011
MAX11614 (ADC)	N/A	0x33 0b011 0011	0x66 0b0110 0110	0x67 0b0110 0111
MAX5815 (DAC)	ADDR1=ADDR0=GND	0x1F 0b001 1111	0x3E 0b0011 1110 0x10* 0b0001 0000	0x3F 0b0011 1111
24AA02 (EEPROM)	N/A	0x50 to 0x57 0b1010xxx	0b1010xxx0	0b1010xxx1

\*MAX5815 ALSO RESPONDS TO AN I2C BROADCAST ADDRESS 0b0001 0000

MAX77278 EV Kit Schematic (continued)

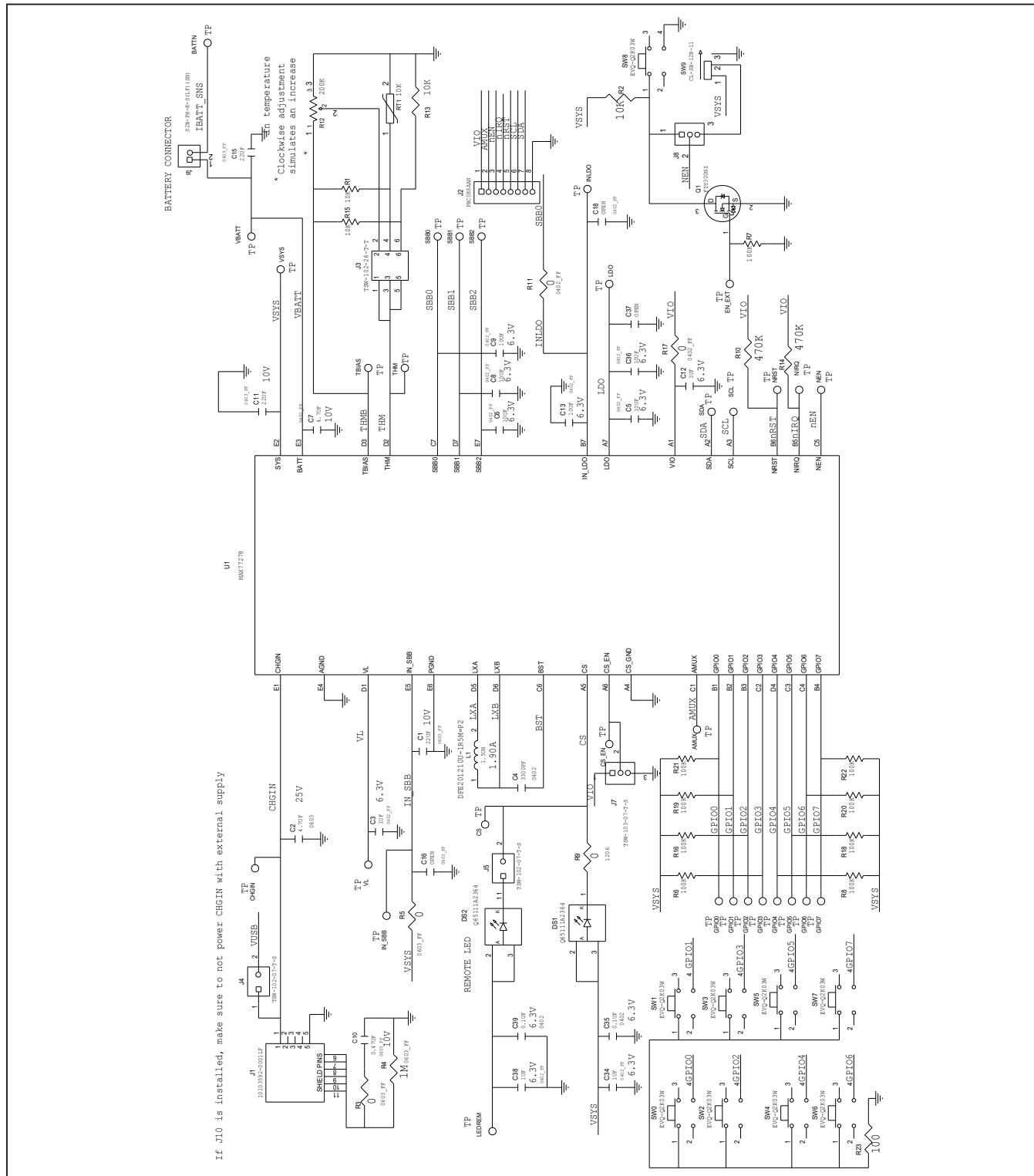

MAX77278 EV Kit Schematic (continued)

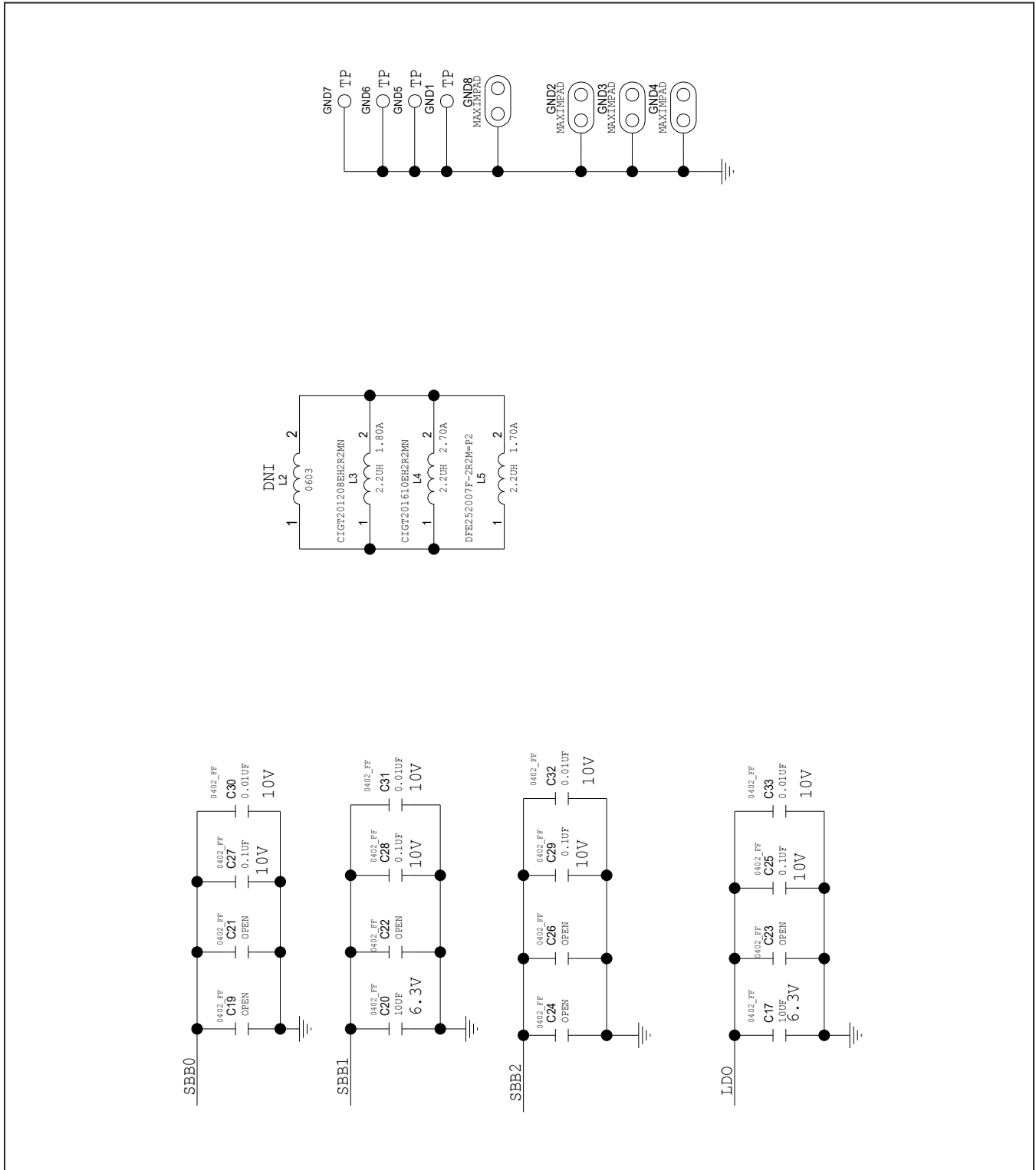

MAX77278 EV Kit Schematic (continued)

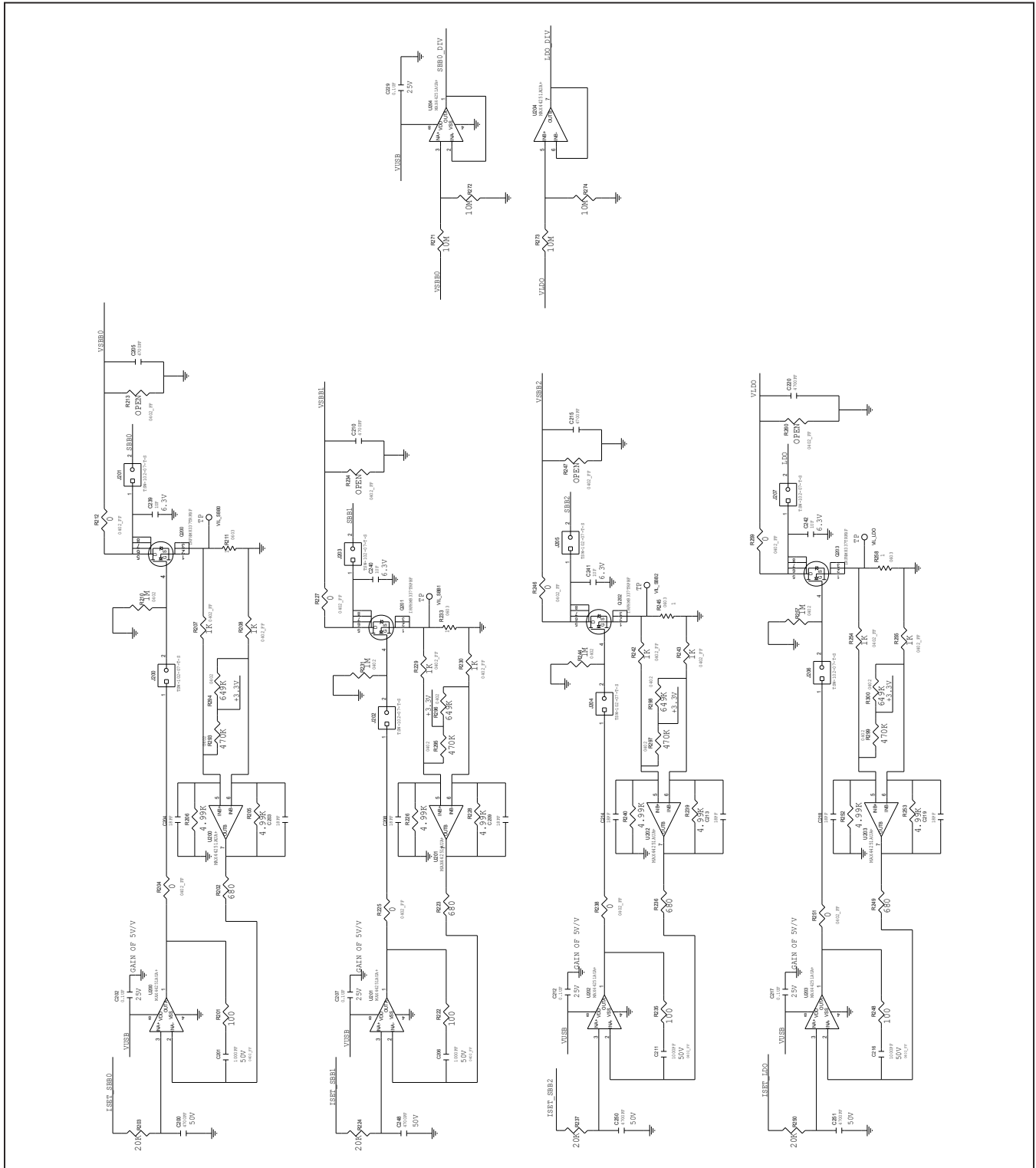





MAX77278 EV Kit Schematic (continued)

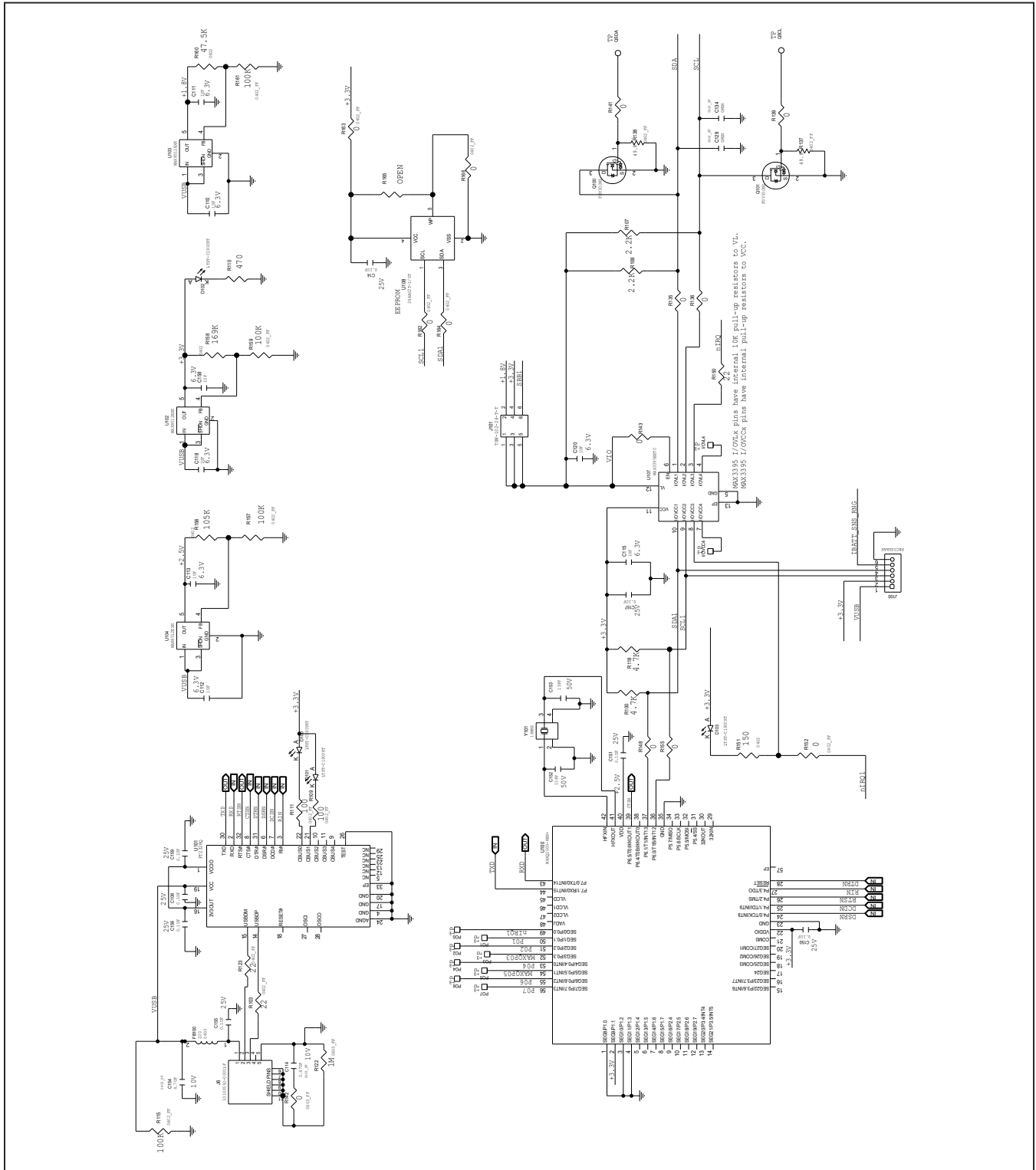

MAX77278 EV Kit PCB Layouts

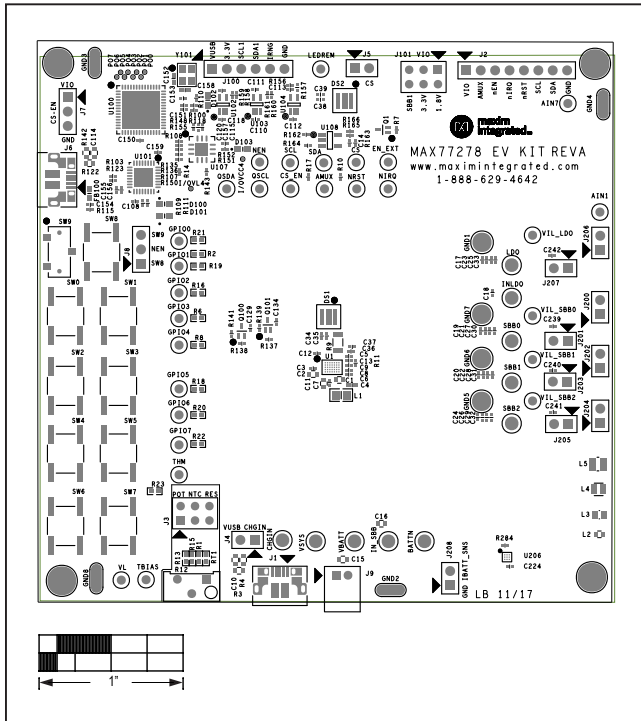

MAX77278 EV Kit Component Placement Guide—Top Silkscreen

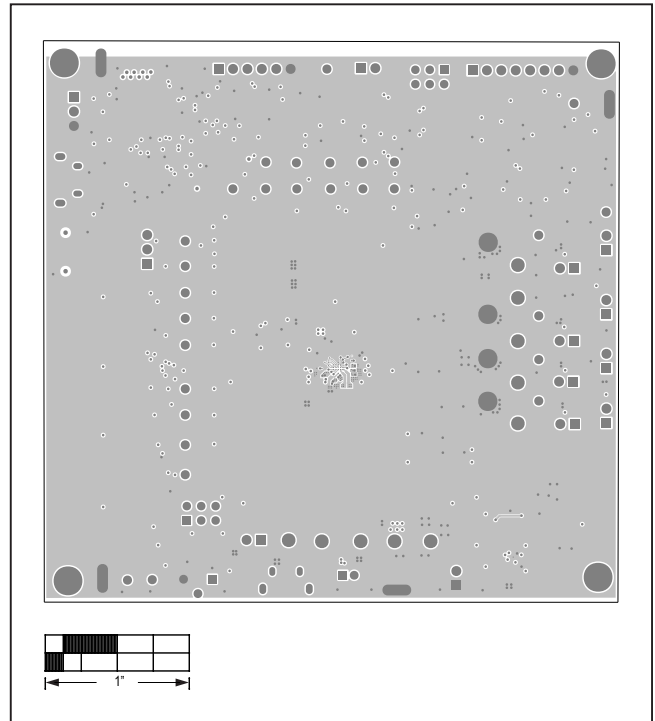

MAX77278 EV Kit PCB Layout—Internal Layer 2

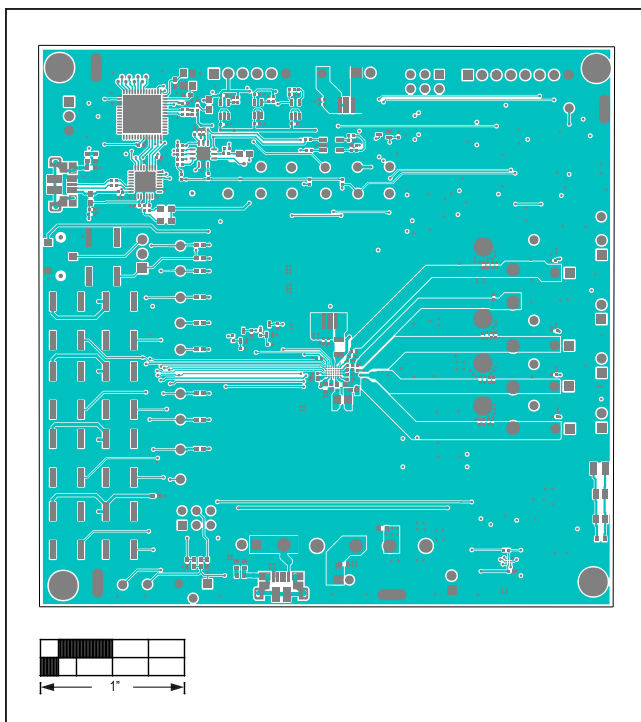

MAX77278 EV Kit PCB Layout—Top Layer

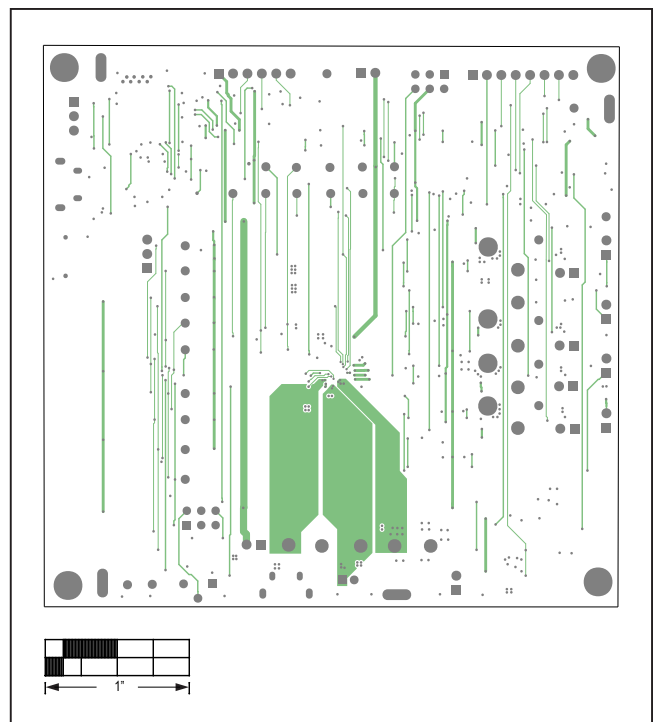

MAX77278 EV Kit PCB Layout—Internal Layer 3

MAX77278 EV Kit PCB Layouts (continued)

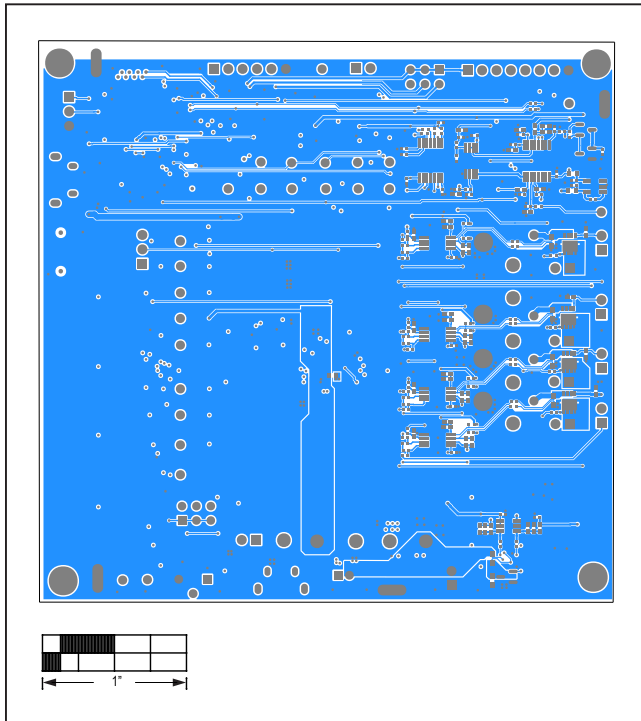

MAX77278 EV Kit PCB Layout—Bottom Layer

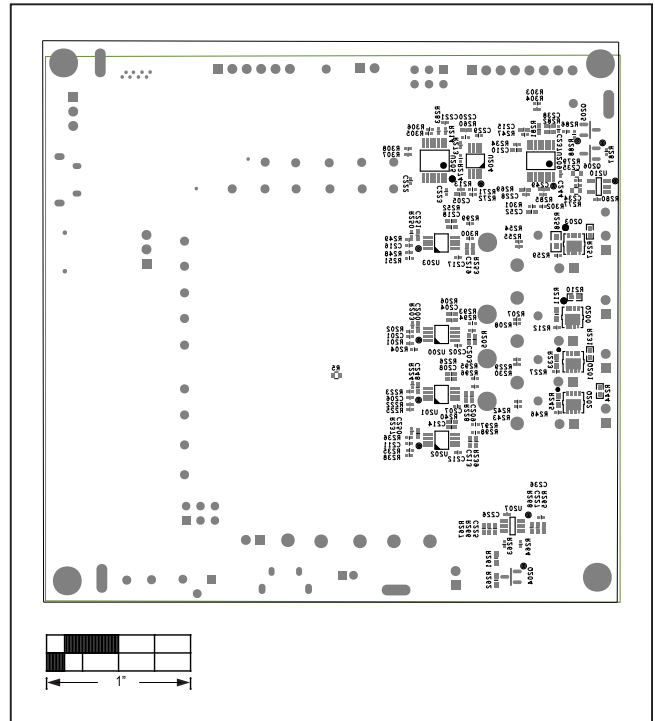

MAX77278 EV Kit Component Placement Guide—Bottom Silkscreen