

MAXIM

MAX774 Evaluation Kit

MAX774 EV Kit

General Description

The MAX774 evaluation kit (EV kit) is a fully assembled and tested surface-mount printed circuit board that provides a regulated -5.0V output voltage from a +5.0V input source. It drives loads up to 1A with conversion efficiency greater than 80%.

Additional pads are provided on the board's solder side to accommodate external feedback resistors for setting different output voltages.

The MAX774 EV kit can also be used to evaluate the MAX775 (-12V output) or MAX776 (-15V output).

Component List

DESIGNATION	QTY	DESCRIPTION
C1	1	150 μ F, 10V low-ESR tantalum capacitor Sprague 595D157X0010D7
C3	1	330 μ F, 10V low-ESR tantalum capacitor Sprague 595D337X0010R7
C2, C4	2	0.1 μ F, 50V ceramic capacitors
R1	1	0.075 Ω resistor (low inductance) IRC LR2010-01-R075-F
R2, R3	0	Open
L1	1	22 μ H, 2.3A power inductor Sumida CDR125-220
D1	1	3A Schottky diode 1N5820 or Nihon NSQ03A03
Q1	1	P-channel FET ($BV_{DS} = 30V$, $r_{DS(ON)} = 130m\Omega$ at 4.5V $_{GS}$), Siliconix Si9435
U1	1	MAX774CSA (8-pin SO)
JU1	1	3-pin header
None	1	Shunt
None	1	PC board
None	1	MAX774 data sheet

Component Suppliers

SUPPLIER	PHONE	FAX
AVX	(800) 282-4975	(207) 283-1941
Coilcraft	(708) 639-6400	(708) 639-1469
Coiltronics	(407) 241-7876	(407) 241-9339
Harris	(407) 724-3739	(407) 724-3937
IRC	(704) 264-8861	(704) 264-8866
Matsuo	(714) 969-2491	(714) 960-6492
Motorola	(800) 521-6274	(602) 244-4015
Nihon	(805) 867-2555	(805) 867-2556
Siliconix	(408) 988-8000	(408) 970-3950
Sprague	(603) 224-1961	(603) 224-1430
Sumida	(708) 956-0666	(708) 956-0702

Features

- ◆ -5.0V or Adjustable Output Voltage
- ◆ Up to 1A Output Current
- ◆ 5 μ A Max Shutdown Current
- ◆ 100 μ A Max Supply Current
- ◆ 300kHz Switching Frequency
- ◆ 8-Pin DIP and SO Packages
- ◆ Surface-Mount Construction
- ◆ Fully Assembled and Tested

Ordering Information

PART	TEMP. RANGE	BOARD TYPE
MAX774EVKIT-SO	0°C to +70°C	Surface Mount

EV Kit

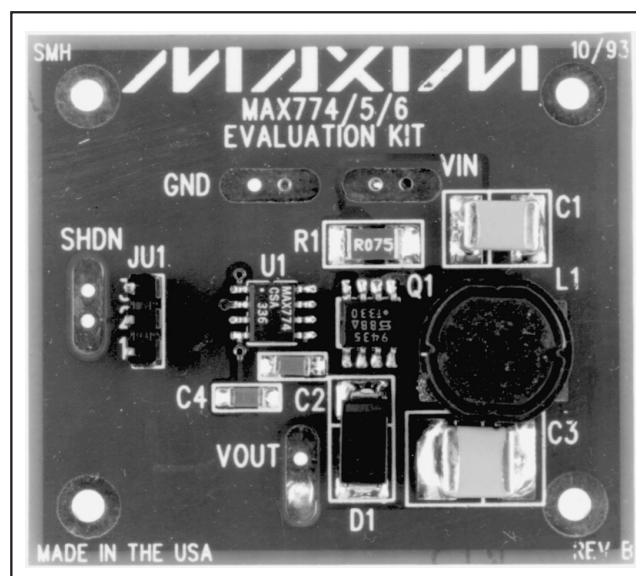
MAXIM

Maxim Integrated Products 1

For pricing, delivery, and ordering information, please contact Maxim Direct at 1-888-629-4642, or visit Maxim's website at www.maxim-ic.com.

MAX774 Evaluation Kit

Quick Reference

The MAX774 EV kit is a fully assembled and tested surface-mount board. Follow the steps below to verify board operation.

Do not turn on the power supply until all connections are completed.

1. Connect a +5.0V supply to the pad marked VIN. Ground connects to the GND pad.
2. Connect a voltmeter and load (if any) to the VOUT pad.
3. Place the shunt on JU1 across pins 1 and 2 for normal operation.
4. Turn on the power and verify the output voltage is -5.0V.
5. Refer to the sections *Evaluating the MAX775 and MAX776* and *Other Output Voltages* to modify the board for different output voltages.

Detailed Description

Jumper Selections

The 3-pin header JU1 selects shutdown mode. Table 1 lists the selectable jumper options.

Inductor Selection

The 22μH Sumida CDR125-220 inductor mounted on the EV kit is a low-resistance, shielded, medium-current inductor. It provides excellent performance over the line and load ranges of the MAX774/MAX775/MAX776. See the *Choosing an Inductor* section of the MAX774/MAX775/MAX776 data sheet for more inductor selection information.

Table 1. Jumper JU1 Functions

SHUNT LOCATION	SHDN PIN	MAX774 OUTPUT
2 & 3	Connected to VIN	Shutdown mode, VOUT = 0V
1 & 2	Connected to GND	MAX774 enabled, VOUT = -5.0V

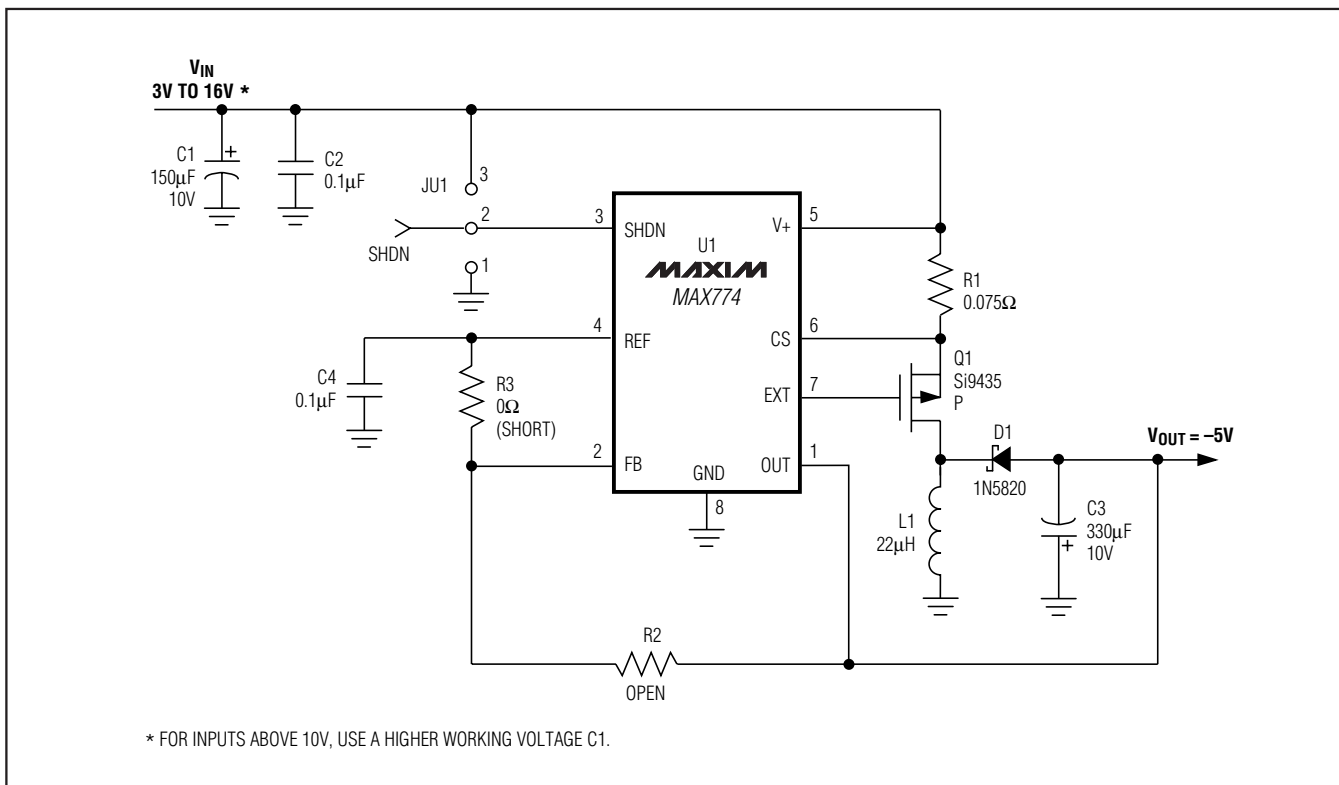

Figure 1. MAX774 EV Kit Schematic Diagram