



MAX8614 Evaluation Kit

General Description

The MAX8614 evaluation kit (EV kit) is a fully assembled and tested surface-mount circuit board. The EV kit contains the MAX8614B (0.8A/0.75A current limit), a dual-output, step-up DC-DC converter that generates an adjustable positive and an adjustable negative output. The EV kit accepts a 2.7V to 5.5V input and provides a +15V and -7.5V output at 1MHz fixed PWM operation.

The MAX8614 EV kit can also be used to evaluate the MAX8614A, a dual-output, step-up DC-DC converter that has a lower current limit (0.44A/0.33A).

Component Suppliers

SUPPLIER	PHONE	WEBSITE
AVX	843-946-0238	www.avxcorp.com
Central	631-435-1110	www.centalsemi.com
Murata	770-436-1300	www.murata.com
Taiyo Yuden	800-348-2496	www.t-yuden.com
TDK	847-803-6100	www.component.tdk.com
TOKO	847-297-0070	www.tokoam.com

Note: Indicate you are using the MAX8614A/MAX8614B when contacting these manufacturers.

DESIGNATION	QTY	DESCRIPTION
C1, C2	2	10 μ F \pm 20%, 6.3V X5R ceramic capacitors (0805) Taiyo Yuden JMKB212106MG TDK C2012X5R0J106M or equivalent
C3	1	4.7 μ F \pm 20%, 25V X5R ceramic capacitor (0805) AVX 08053D475MAT or equivalent
C4	1	2.2 μ F \pm 10%, 25V X5R ceramic capacitor (0805) Murata FRM219R61E225KA TDK C2012S5R1E225K or equivalent
C5	1	1 μ F \pm 20%, 6.3V X5R ceramic capacitor (0402) Taiyo Yuden JMK105BJ105MV TDK C1005X5R0J105M or equivalent
C6	1	1 μ F \pm 10%, 16V X5R ceramic capacitor (0603) Murata GRM188R61C1405K TDK C1608X5R1C105K or equivalent
C7	1	0.22 μ F \pm 20%, 6.3V X5R ceramic capacitor (0402) TDK C1005X5R0J224M or equivalent

Features

- ◆ 2.7V to 5.5V Input Range
- ◆ Adjustable Output
V_{BST} = +15V (At 20mA)
V_{INV} = -7.5V (At 80mA)
- ◆ Adjustable Up to +24V and Down to -10V at a +5.5V Input
- ◆ 0.1 μ A (typ) IC Shutdown Current
- ◆ Fixed 1MHz PWM Switching Frequency
- ◆ Surface-Mount Component Construction
- ◆ Fully Assembled and Tested

Ordering Information

PART	TEMP RANGE	IC PACKAGE
MAX8614EVKIT	0°C to +70°C	14 TDFN (3mm x 3mm)

Component List

DESIGNATION	QTY	DESCRIPTION
D1, D2	2	20V, 0.5A Schottky diodes (SOD-123) Central CMHSH5-2L (top mark: C2L)
JU1, JU2, JU3	3	3-pin headers
L1	1	2.0 μ H, 1.4A power inductor TOKO 1098AS-2R0M
L2	1	4.7 μ H, 0.8A power inductor TOKO 1068AS-4R7N (top mark: AJ)
R1	1	150k Ω \pm 1% resistor (0402)
R2	1	24.9k Ω \pm 1% resistor (0402)
R3	1	698k Ω \pm 1% resistor (0402)
R4	1	49.9k Ω \pm 1% resistor (0402)
R5	1	100k Ω \pm 5% resistor (0402)
U1	1	MAX8614BETD+ (14-pin TDFN, 3mm x 3mm)
—	3	Shunts
—	1	MAX8614 PC board

Evaluates: MAX8614A/MAX8614B

MAX8614 Evaluation Kit

Quick Start

The MAX8614 EV kit is fully assembled and tested. Follow these steps to verify board operation. **Do not turn on the power supply until all connections are completed.**

Recommended Equipment

- 3.6V, 2A power supply
- Two voltage meters

Procedure

- 1) Verify that shunts are across pins 1 and 2 of jumpers JU1 (ONBST = high) and JU3 (ONINV = high); pins 2 and 3 of jumper JU2 (SEQ = low).
- 2) Connect the 3.6V power supply to the VBATT pad. Connect the power-supply ground to the GND pad.
- 3) Connect a voltmeter and load (if any) across the VBST and GND pads, and connect another voltmeter and load (if any) across the VINV and GND pads.
- 4) Turn on the power supply.
- 5) Verify that outputs are VBST = +15V and VINV = -7.5V.

Detailed Description

The MAX8614 EV kit is a fully assembled tested surface-mount circuit board. The EV kit generates both a positive 15V and negative 7.5V output. The positive output delivers up to 20mA while the inverter supplies up to 80mA with a 2.7V to 5.5V input voltage.

Jumper Selection

The MAX8614 EV kit incorporates jumpers JU1, JU2, and JU3 to control the ONBST, SEQ, and ONINV pins, respectively. See Tables 1, 2, and 3 for jumper functions.

Table 1. JU1 Functions (ONBST)

JU1 SHUNT LOCATION	ONBST PIN	VBST OUTPUT
Pins 1 and 2 (default)	Connected to VPWR	Enabled
Pins 2 and 3	Connected to GND	Disabled
Open	Connected to ONBST pad	VBST output state depends on the external ONBST signal level

Table 2. JU2 Functions (SEQ)

JU2 SHUNT LOCATION	SEQ PIN	EV KIT POWER-ON SEQUENCING
Pins 1 and 2	Connected to VPWR	Boost output power on first
Pins 2 and 3 (default)	Connected to GND	Both outputs power on at the same time (if ONBST = ONINV or can be controlled independently with ONBST and ONINV)
Open	Connected to SEQ pad	Power-on sequencing depends on the external SEQ signal level

Table 3. JU3 Functions (ONINV)

JU3 SHUNT LOCATION	ONINV PIN	VINV OUTPUT
Pins 1 and 2 (default)	Connected to VPWR	Enabled
Pins 2 and 3	Connected to GND	Disabled
Open	Connected to ONINV pad	VBST output state depends on the external ONINV signal level

Evaluating Other Output Voltages

The MAX8614 EV kit output voltages are preset at +15V and -7.5V. To generate voltages other than the preset voltages, change the feedback resistors R1 to R4.

Select the feedback resistors R2 and R4 in the 20kΩ to 100kΩ range. R1 is then given by:

$$R1 = R2 \times (-VINV) / V_{REF}$$

where $V_{REF} = 1.25V$.

R3 is given by:

$$R3 = R4 \times (VBST - V_{FBP})$$

where $V_{FBP} = 1.01V$.

Evaluating the MAX8614A

The MAX8614 EV kit can be used to evaluate the MAX8614A. To evaluate the MAX8614A with the MAX8614 EV kit, replace the MAX8614BETD+ with the MAX8614AETD+. The power output capability will be reduced. Refer to the MAX8614A/MAX8614B data sheet for selection of components.

MAX8614 Evaluation Kit

Evaluates: MAX8614A/MAX8614B

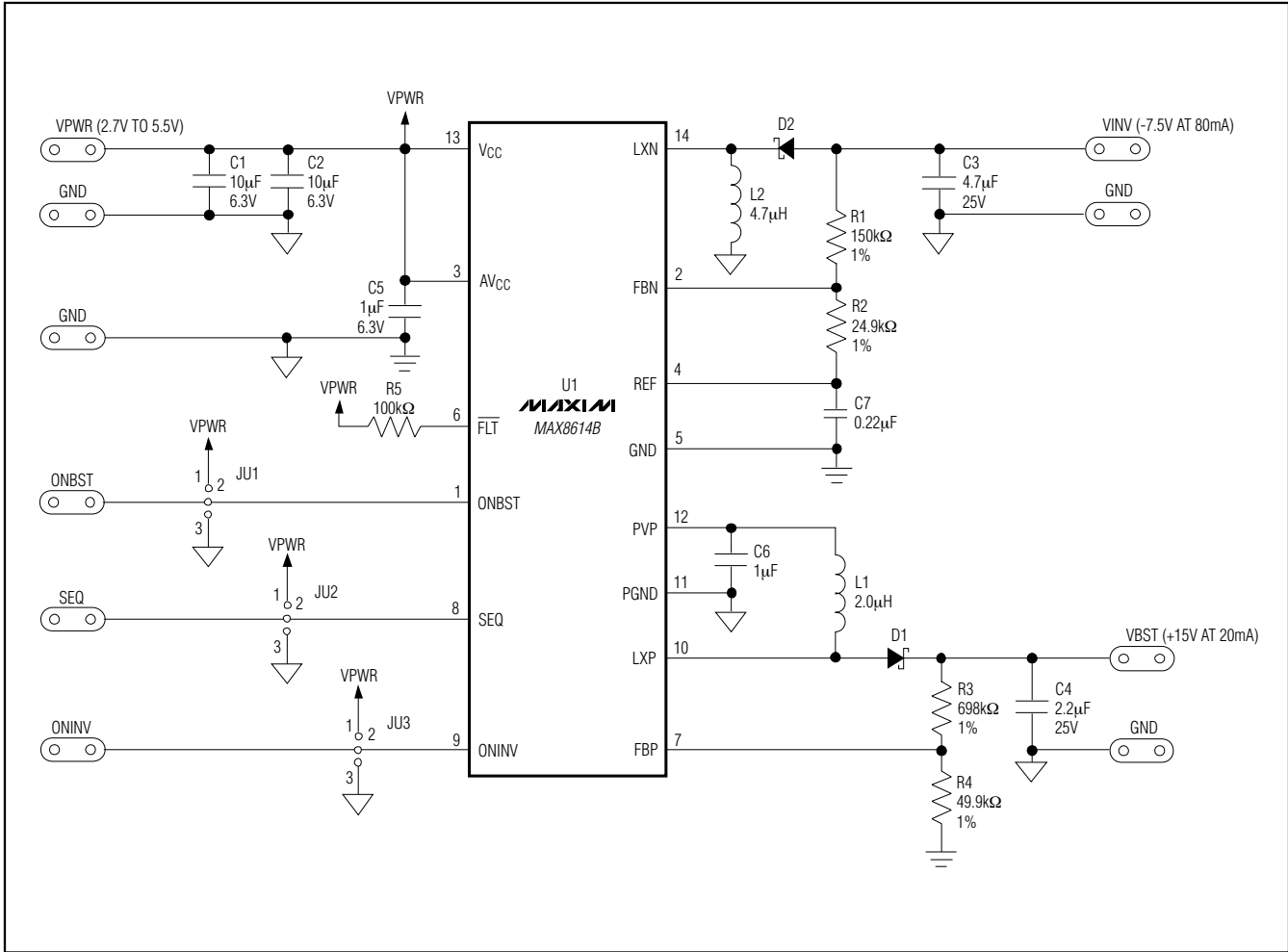

Figure 1. MAX8614 EV Kit Schematic