



MAX9613 Evaluation Kit

Evaluates: MAX9613

General Description

The MAX9613 evaluation kit (EV kit) provides a proven design to evaluate the MAX9613 low-power, MOS-input operational amplifier (op amp) in a 6-pin SC70 package. The EV kit circuit is preconfigured as a noninverting amplifier, but can easily be adapted to other topologies by changing a few components. Low-power, low-input Vos, and rail-to-rail input/output stages make this device ideal for a variety of measurement applications. The component pads accommodate 0805 packages, making them easy to solder and replace. The EV kit comes with a MAX9613AXT+ installed.

Features

- ◆ Accommodates Multiple Op-Amp Configurations
Component Pads Allow for Sallen-Key Filter
- ◆ Rail-to-Rail Inputs/Outputs
- ◆ Accommodates Easy-to-Use 0805 Components
- ◆ Proven PCB Layout
- ◆ Fully Assembled and Tested

Ordering Information

PART	TYPE
MAX9613EVKIT+	EV Kit

+Denotes lead(Pb)-free and RoHS compliant.

Component List

DESIGNATION	QTY	DESCRIPTION
C1	1	0.1 μ F \pm 10%, 16V X7R ceramic capacitor (0603) Murata GRM188R71C104K
C2	1	4.7 μ F \pm 10%, 6.3V X5R ceramic capacitor (0603) Murata GRM188R60J475K
C3, C4, C8, C9	0	Not installed, ceramic capacitors (0805)
GND	2	Black multipurpose test points
INM, INP, OUTA	3	White multipurpose test points
JU1	1	2-pin header

DESIGNATION	QTY	DESCRIPTION
JU2	1	3-pin header
R1, R2	2	1k Ω \pm 1% resistors (0805)
R5	1	10k Ω \pm 1% resistor (0805)
R6, R8	2	0 Ω \pm 5% resistors (0805)
VDD	1	Red multipurpose test point
U1	1	Single low-power, rail-to-rail I/O op amp (6 SC70) Maxim MAX9613AXT+ (Top Mark: +ADK)
—	2	Shunts
—	1	PCB: MAX9613 EVALUATION KIT+

Component Supplier

SUPPLIER	PHONE	WEBSITE
Murata Electronics North America, Inc.	770-436-1300	www.murata-northamerica.com

Note: Indicate that you are using the MAX9613 when contacting this component supplier.

MAX9613 Evaluation Kit

Quick Start

Required Equipment

- MAX9613 EV kit
- +5V, 10mA DC power supply (PS1)
- Precision voltage source
- Digital multimeter (DMM)

Procedure

The EV kit is fully assembled and tested. Follow the steps below to verify board operation:

- 1) Verify that jumpers JU1 and JU2 are in their default positions, as shown in Table 1.
- 2) Connect the positive terminal of the +5V supply to the VDD test point and the negative terminal to the GND test point closest to VDD.
- 3) Connect the positive terminal of the precision voltage source to the INP test point. Connect the negative terminal of the precision voltage source to GND (GND or INM test points).
- 4) Connect the DMM to monitor the voltage on the OUTA test point. With the 10kΩ feedback resistor (R5) and 1kΩ series resistor (R1), the gain is +11 (noninverting configuration).
- 5) Turn on the +5V power supply.
- 6) Apply 100mV from the precision voltage source. Observe the output at OUTA on the DMM, which should read approximately +1.1V.

Table 1. EV Kit Jumper Descriptions (JU1, JU2)

JUMPER	SHUNT POSITION	DESCRIPTION
JU1	1-2*	Connects the INM test point to GND.
	Open	Isolates the INM test point from GND.
JU2	1-2*	Connects $\overline{\text{SHDN}}$ to VDD (normal operation).
	2-3	Connects $\overline{\text{SHDN}}$ to GND (shutdown).

*Default position.

- 7) Apply 400mV from the precision voltage source. OUTA should read approximately +4.4V.

Detailed Description of Hardware

The MAX9613 EV kit provides a proven layout for the MAX9613 low-power, MOS-input op amp. The device is a single-supply op amp that is ideal for buffering sensor signals. A Sallen-Key 2nd-order active filter, as described in the *Sallen-Key Configuration* section, is easily accomplished by changing and removing some components. Various test points are included for easy evaluation.

Op-Amp Configurations

The device is a single-supply op amp that is ideal for differential sensing, noninverting amplification, buffering, and filtering. A few common configurations are shown in the next few sections.

Noninverting Configuration

The EV kit comes preconfigured as a noninverting amplifier with a gain of +11. The gain is set by the ratio of R5 and R1 (Figure 1). For a voltage applied to the INP test point, the output voltage for the noninverting configuration is given by the equation below:

$$V_{OUT} = \left(1 + \frac{R_5}{R_1}\right) V_{INP}$$

Differential Amplifier

To configure the EV kit as a differential amplifier, replace R1, R2, RC3, and R5 with appropriate resistors. When R1 = R2 and R5 = RC3, the common-mode rejection

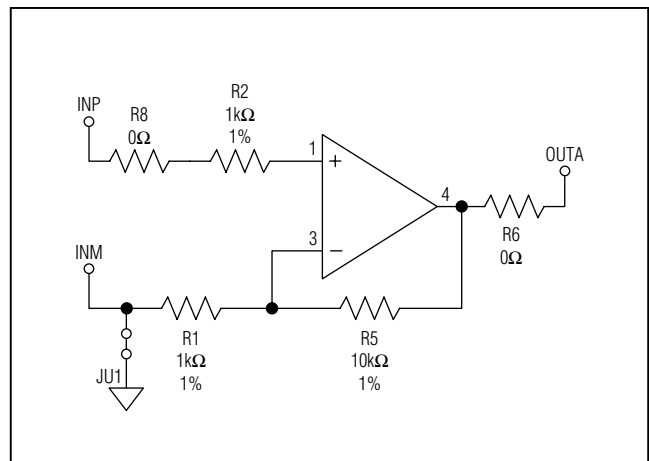

Figure 1. Default Noninverting Configuration with Gain +11

MAX9613 Evaluation Kit

Evaluates: MAX9613

ratio (CMRR) of the differential amplifier is determined by the matching of the resistor ratios $R5/R1$ and $Rc3/R2$ (Figure 2).

$$V_{OUT} = GAIN (V_{INP} - V_{INM})$$

where:

$$GAIN = \frac{R5}{R1} = \frac{Rc3}{R2}$$

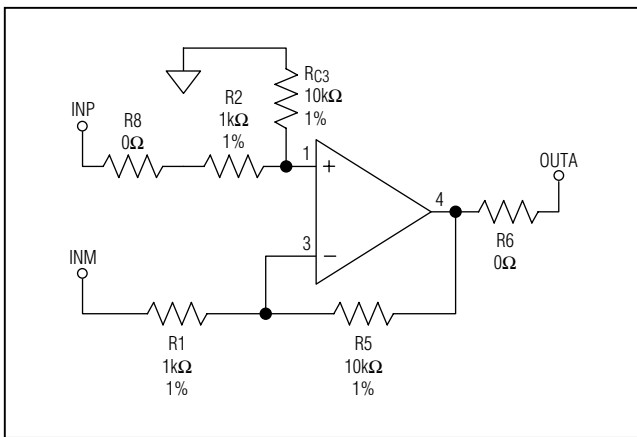

Figure 2. Differential Configuration with Gain +10

Sallen-Key Configuration

The Sallen-Key active filter topology is ideal for sensor signal conditioning with a 2nd-order filter. These filters benefit from a rail-to-rail input structure with no crossover distortion, such as that available on the device.

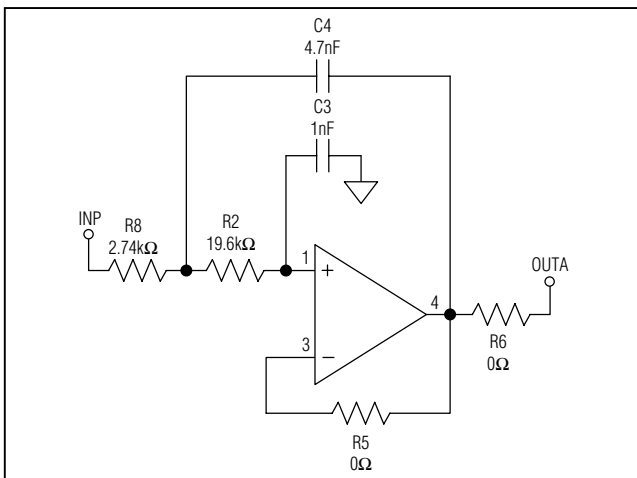

Figure 3. Lowpass 2nd-Order Filter Sallen-Key Configuration for 10kHz

Lowpass Sallen-Key Filter
To configure the Sallen-Key as a lowpass filter, populate the R2 and R8 pads with resistors, and populate the C3 and C4 pads with capacitors. The corner frequency and Q are then given by (Figure 3):

$$f_C = \frac{1}{2\pi\sqrt{R2 \times C3 \times R8 \times C4}}$$

$$Q = \frac{\sqrt{R2 \times C3 \times R8 \times C4}}{C3 (R2 + R8)}$$

Highpass Sallen-Key Filter

To configure the Sallen-Key as a highpass filter, populate the C3 and C4 pads with resistors, and populate the R2 and R8 pads with capacitors. The corner frequency and Q are then given by (Figure 4):

$$f_C = \frac{1}{2\pi\sqrt{C_{R8} \times R_{C4} \times C_{R2} \times R_{C3}}}$$

$$Q = \frac{\sqrt{C_{R8} \times R_{C4} \times C_{R2} \times R_{C3}}}{R_{C4} (C_{R2} + C_{R8})}$$

Capacitive Loads

Some applications require driving large capacitive loads. To improve the stability of the amplifier in such cases, either replace R6 with a suitable resistor value to improve amplifier phase margin in the presence of capacitive load C9, or apply a resistive load in parallel with C9.

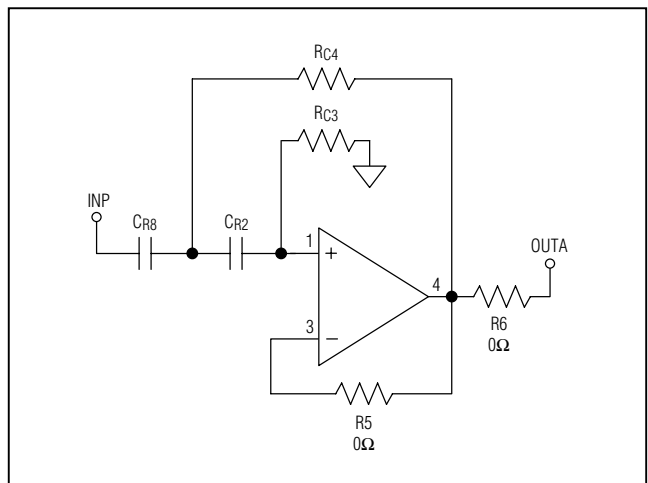

Figure 4. Generic 2nd-Order Highpass Sallen-Key Filter

MAX9613 Evaluation Kit

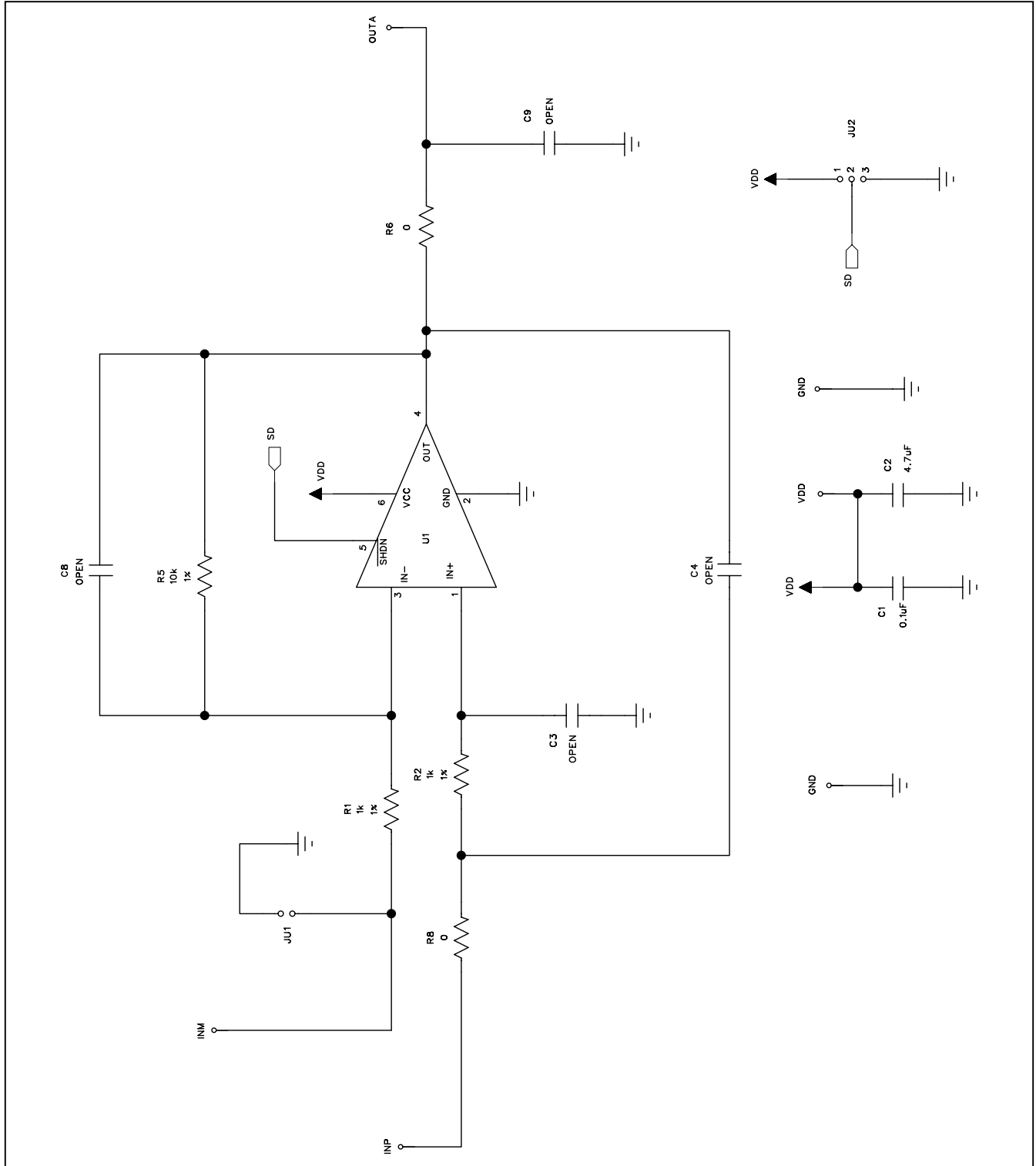

Figure 5. MAX9613 EV Kit Schematic

MAX9613 Evaluation Kit

Evaluates: MAX9613

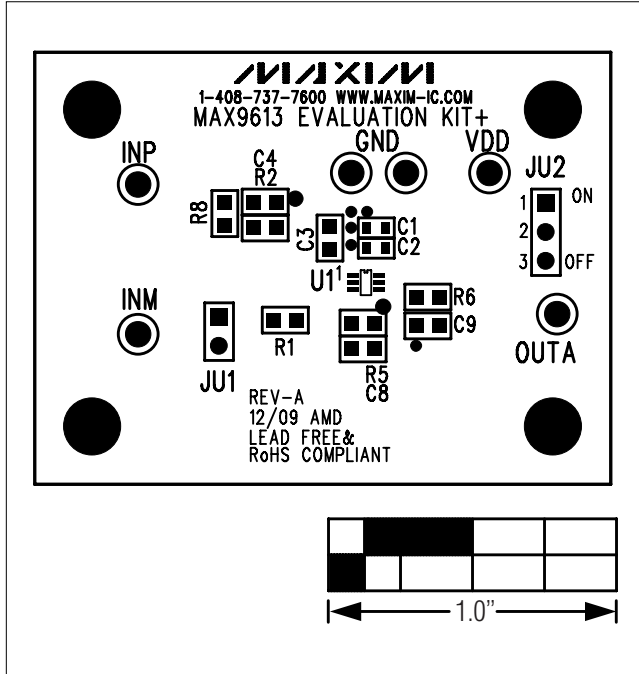

Figure 6. MAX9613 EV Kit Component Placement Guide—Component Side

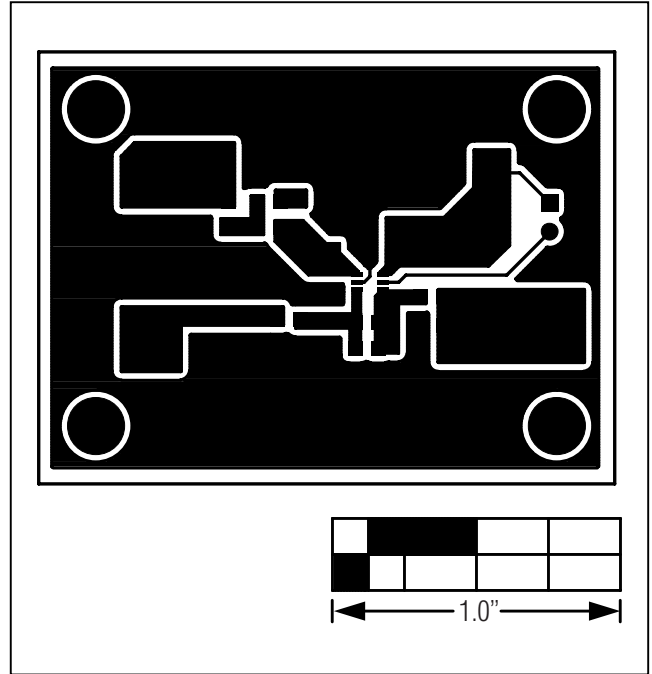

Figure 7. MAX9613 EV Kit PCB Layout—Component Side

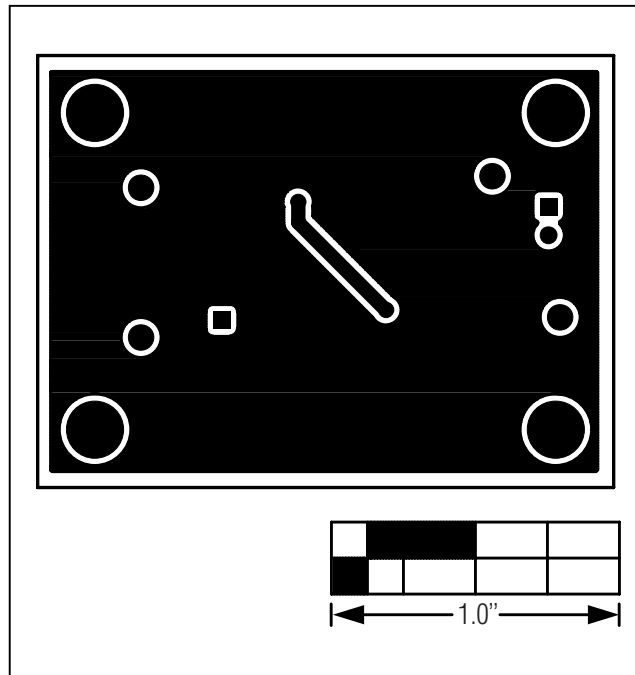

Figure 8. MAX9613 EV Kit PCB Layout—Solder Side