



MAX9850 Evaluation System/Evaluation Kit

Evaluate: MAX9850

General Description

The MAX9850 evaluation system (EV system) consists of a MAX9850 evaluation kit (EV kit), a companion Maxim command module (CMOD232) interface board, and software.

The MAX9850 EV kit is a fully assembled and tested surface-mount printed circuit board (PCB) that evaluates the MAX9850 headphone stereo DAC with integrated headphone driver. The EV kit is designed to be driven by any digital audio Sony/Philips Digital Interface (S/PDIF) audio source and can be optionally configured to accept generic digital audio or I²S-compatible signals. The EV kit provides RCA jacks for connecting analog input signals. A 3.5mm headphone jack allows for easy connection of headphones to the PCB.

The Maxim command module interface board (CMOD232) allows a PC to use its serial port to emulate an I²C 2-wire interface. Windows[®] 98/2000/XP-compatible software, which can be downloaded from the Maxim website, provides a user-friendly interface to exercise the features of the MAX9850. The program is menu driven and offers a graphical user interface (GUI) with control buttons and a status display.

The MAX9850 EV system (MAX9850EVCMOD2#) includes both the EV kit and the CMOD232 interface board. Order the MAX9850 EV kit (MAX9850EVKIT#) if you already have a command module interface.

Windows is a registered trademark of Microsoft Corp.

Features

- ◆ 1.8V to 3.6V Single-Supply Operation
- ◆ I²C-Compatible 2-Wire Serial Interface
- ◆ Selectable Optical/Electrical S/PDIF Input
- ◆ On-Board 12MHz Crystal Oscillator
- ◆ On-Board Digital Audio Receiver
- ◆ No Detectable Clicks or Pops
- ◆ Easy-to-Use Menu-Driven Software
- ◆ Assembled and Tested
- ◆ Includes Windows 98/2000/XP-Compatible Software and Demo PCB

Ordering Information

PART	TEMP RANGE	IC PACKAGE	I ² C INTERFACE TYPE
MAX9850EVKIT#	0°C to +70°C	28 TQFN	Not included
MAX9850EVCMOD2#	0°C to +70°C	28 TQFN	CMOD232

#Denotes RoHS compliant.

Note: The CMOD232 board is required to interface the EV kit to the computer when using the software.

Component Lists

MAX9850 EV System

PART	QTY	DESCRIPTION
MAX9850EVKIT#	1	MAX9850 EV kit
CMOD232+	1	SMBus/I ² C interface board
AC Adapter	1	9VDC at 200mA (powers the CMOD232 board)

#Denotes RoHS compliant.

+Denotes lead-free and RoHS compliant.

MAX9850 EV Kit

DESIGNATION	QTY	DESCRIPTION
C1, C2	2	220µF ±20%, 6.3V tantalum capacitors (C-case) AVX TPSC227M006R0070 or AVX TPSC227M006R0100
C3, C4	0	Not installed, capacitors (C-case)

MAX9850 EV Kit (continued)

DESIGNATION	QTY	DESCRIPTION
C5–C8	4	10µF ±20%, 6.3V X5R ceramic capacitors (0805) TDK C2012X5R0J106M
C9–C12, C15–C23, C30, C31, C37, C43	17	1.0µF ±20%, 6.3V X5R ceramic capacitors (0402) TDK C1005X5R0J105M
C13	1	2.2µF ±20%, 6.3V X5R ceramic capacitor (0603) TDK C1608X5R0J225M
C14	1	0.47µF ±20%, 16V X7R ceramic capacitor (0603) TDK C1608X7R1C474M
C24–C29, C35, C44, C45	9	0.1µF ±20%, 10V X5R ceramic capacitors (0402) TDK C1005X5R1A104M



MAX9850 Evaluation System/Evaluation Kit

Component Lists (continued)

DESIGNATION	QTY	DESCRIPTION
C32, C33, C34, C36, C38, C39	6	0.01 μ F \pm 5%, 25V C0G ceramic capacitors (0603) TDK C1608C0G1E103J
C40	1	0.022 μ F \pm 10%, 25V X7R ceramic capacitor (0402) TDK C1005X7R1E223K
C41	1	1000pF \pm 5%, 50V C0G ceramic capacitor (0603) TDK C1608C0G1H102J
C42	0	Not installed (0603)
J1	1	2 x 10 right-angle female receptacle
J2	1	Digital audio optical receiver Toshiba TORX147L
J3, J5	2	Phono jacks, red
J4, J6	2	Phono jacks, white
J7	1	Phono jack, yellow
J8	1	Switched stereo headphone jack (3.5mm dia)
J9	1	SMA PC-mount connector
J10	1	8-pin header
JU1	1	Dual-row 6-pin header
JU2	1	2-pin header
JU3	1	3-pin header
L1	1	3.3 μ H \pm 10%, 270mA inductor (1812) Coilcraft 1812CS-332XKL
L2	1	47 μ H \pm 10%, 200mA inductor (1812) Coilcraft 1812LS-473XKL
R1, R2, R3, R13	4	1k Ω \pm 5% resistors (0603)
R4	1	47k Ω \pm 5% resistor (0603)
R5	1	75 Ω \pm 5% resistor (0603)
R6, R7, R8, R12	0	Not installed, resistors (0603)
R9, R10	2	1k Ω \pm 5% resistors (0402)

DESIGNATION	QTY	DESCRIPTION
R11	1	3.01k Ω \pm 1% resistor (0603)
R14	0	Not installed, resistor—short (PC trace) (1206)
R15	1	4.7k Ω \pm 5% resistor (0603)
SW1	0	Not installed
U1	1	Stereo audio DAC (28 TQFN) Maxim MAX9850ETI+
U2	1	192kHz digital audio receiver (28 TSSOP) Cirrus Logic CS8416-CZZ
U3	1	Level translator (10 μ MAX [®]) Maxim MAX1840EUB+
U4	1	16-bit, dual-supply bus transceiver (48 TSSOP) Texas Instruments SN74AVCAH164245GR
U5	1	Dual/triple voltage microprocessor supervisor (5 SC70) (Top Mark: AFS) Maxim MAX6736XKTGD3+
U6, U7	2	2:1 noninverting multiplexers (6 SC70) Fairchild Semi NC7SV157P6X_NL (Top Mark: VF7)
U8	1	Schmitt trigger buffer (5 SC70) Fairchild Semi NC7SV17P5X_NL (Top Mark: V17)
Y1	1	Low-jitter crystal clock oscillator CTS Frequency Controls CB3LV-3C-12.0000-T
—	3	Shunts
—	1	PCB: MAX9850 Evaluation Kit#

#Denotes RoHS compliant.

Component Suppliers

SUPPLIER	PHONE	FAX	WEBSITE
AVX Corp.	843-946-0238	843-626-3123	www.avxcorp.com
Coilcraft, Inc.	847-639-6400	847-639-1469	www.coilcraft.com
TDK Corp.	847-803-6100	847-390-4405	www.component.tdk.com

Note: Indicate that you are using the MAX9850 when contacting these component suppliers.

μ MAX is a registered trademark of Maxim Integrated Products, Inc.

MAX9850 Evaluation System/Evaluation Kit

MAX9850 EV Kit Files

FILE	DESCRIPTION
INSTALL.EXE	Installs the EV kit files on your computer
MAX9850.EXE	Application program
UNINST.INI	Uninstalls the EV kit software

Quick Start

Recommended Equipment

- Computer running Windows 98, 2000, or XP
- Serial port (this is a 9-pin socket on the back of the computer)
- Standard 9-pin, straight-through, male-to-female cable (serial extension cable) to connect the computer's serial port to the Maxim command module interface board
- CMOD232 command module with included wall cube power source
- Two 3.0V/100mA DC power supplies
- One pair of headphones (16Ω or greater)
- One digital audio S/PDIF signal source

Procedure

The MAX9850 EV kit is fully assembled and tested. Follow the steps below to verify board operation.

Caution: Do not turn on the power supply until all connections are completed.

Command Module Setup

- 1) Enable the SDA/SCL pullup resistors on the command module by setting both switches (SW1) to the on position.
- 2) Set the command module working voltage to 3.3V by placing a shunt across pins 1-2 of the VDD select jumper.
- 3) Connect a cable from the computer's serial port to the command module (CMOD232) interface board. Use a *straight-through* 9-pin male-to-female cable. To avoid damaging the EV kit or your computer, do not use a 9-pin null-modem cable or any other proprietary interface cable that is physically similar to the straight-through cable.
- 4) Connect the provided wall cube power supply to the CMOD232 board.

EV Kit Setup

- 1) Visit www.maxim-ic.com/evkitsoftware to download the latest version of the EV kit software, 9850Rxx.ZIP. Save the EV kit software to a temporary folder and uncompress the ZIP file.
- 2) Install the EV kit software on your computer by running the INSTALL.EXE program inside the temporary folder. The program files are copied and icons are created in the Windows **Start | Programs** menu.
- 3) Ensure that the I²C address of the MAX9850 is set to 0x20h by verifying that a shunt is placed across pins 1-2 of jumper JU1.
- 4) Ensure that a shunt is installed on jumper JU2
- 5) Connect the first 3.0V power supply to the DVDD and corresponding GND pads.
- 6) Connect the second 3.0V power supply to the PVDD and corresponding GND pads.
- 7) Connect the S/PDIF signal source to either J2 (optical) or J7 (electrical)
- 8) Insert a pair of 16Ω headphones into the headphone jack J8.
- 9) Carefully align the 20-pin connector of the MAX9850 EV kit with the 20-pin header of the CMOD232 interface board. Gently press them together.
- 10) Plug the CMOD232 wall cube into an electrical outlet.
- 11) Turn on both of the 3.3V power supplies
- 12) Enable the stereo audio sources.
- 13) Start the MAX9850 program by opening its icon in the **Start | Programs** menu.
- 14) Normal device operation can be verified by the "Status: MAX9850 Operational" text in the Interface box.
- 15) To autoconfigure the MAX9850 in a functional state, use the "auto setup" feature in the MAX9850 software.

Evaluate: MAX9850

MAX9850 Evaluation System/Evaluation Kit

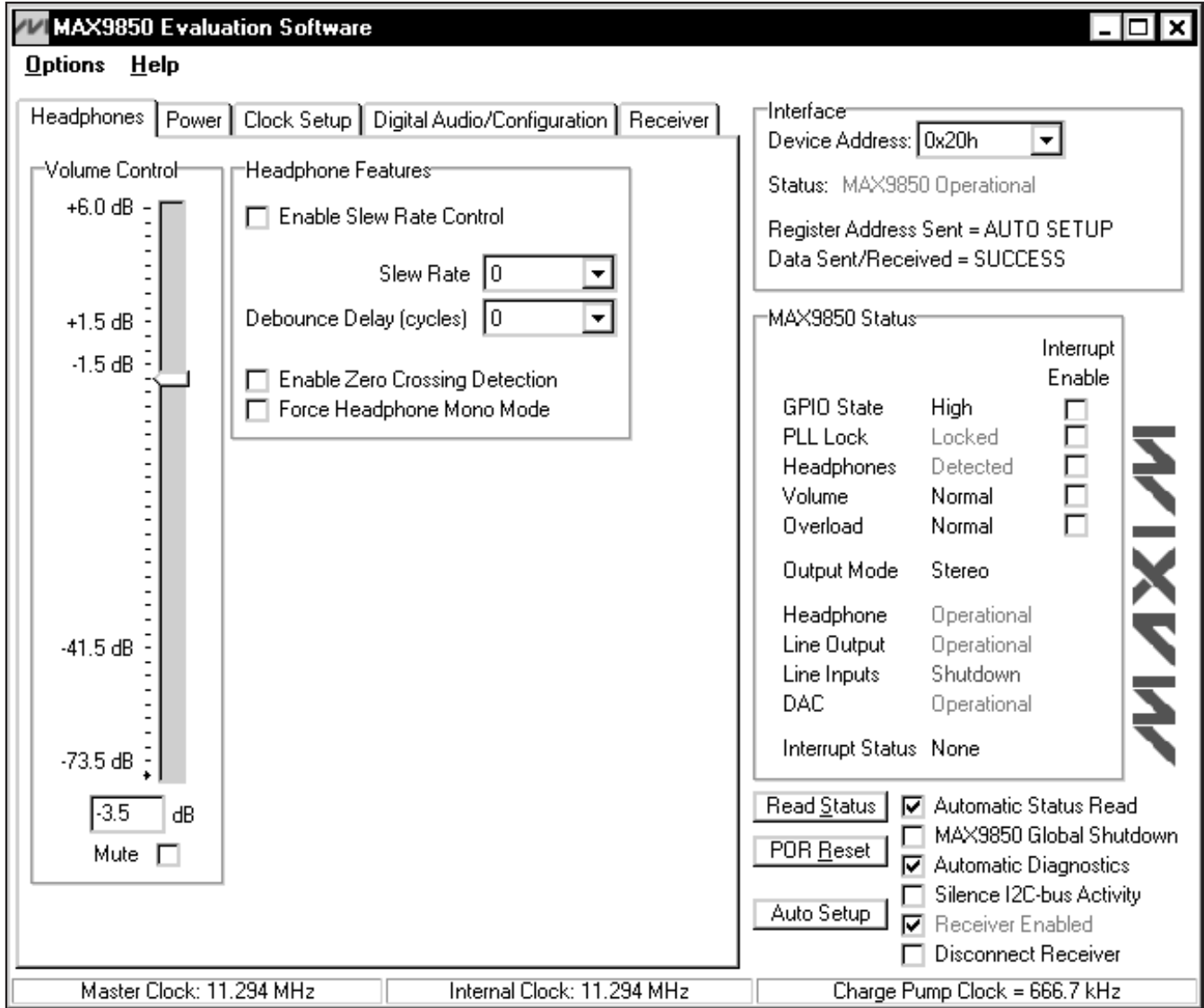

Figure 1. MAX9850 EV Kit Software Main Window

Detailed Description of Software

Note: Words in bold are user-selectable features and status flags in the software.

User-Interface Panel

The user interface (Figure 1) is easy to operate; use the mouse, or a combination of the Tab and Arrow keys to manipulate the software. Each of the buttons corresponds to bits in the command and configuration bytes. By clicking on them, the correct I²C write opera-

tion is generated to update the internal registers of the MAX9850 or the on-board S/PDIF receiver.

The software divides EV kit functions into logical blocks. The **Interface** box indicates the current **Device Address**, the **Register Address Sent**, and the **Data Sent/Received** for the last read/write operation. This data is used to confirm proper device operation. **Headphone**, **Power**, **Clock Setup**, **Digital Audio/Configuration**, and **Receiver** functions are accessed through tab sheets. MAX9850 status and interrupt control are accessed through the **MAX9850 Status** box.

MAX9850 Evaluation System/Evaluation Kit

The status bar displays vital MAX9850 clock information. Return the EV kit to its power-on-reset state by clicking the **POR Reset** button. Power up the MAX9850 by clearing the **MAX9850 Global Shutdown** checkbox. Power up the receiver (U2) by selecting the **Receiver Enabled** checkbox.

The MAX9850 EV kit software features additional functions to simplify operation. **Automatic Diagnostics** probes the command module board and the MAX9850 EV kit to make sure that all connections are made, and all devices are working. This will create some activity on the I²C bus. The **Silence I²C-bus Activity** checkbox will reduce I²C bus activity to allow easy triggering of an oscilloscope.

The **Auto Setup** button further reduces user input. When this button is pressed, the software will do the following:

- 1) Search both EV kit S/PDIF inputs for a valid signal and then set the on-board multiplexer accordingly.
- 2) Power up the receiver IC as well as vital sections of the MAX9850.
- 3) Set internal clock dividers based on the incoming master clock frequency.

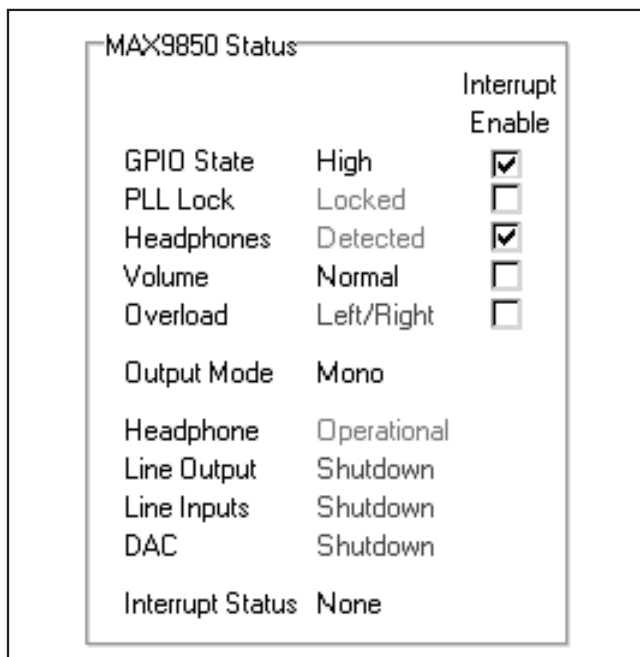

Figure 2. MAX9850 EV Kit Software Status Window

- 4) Set the MSB(14:8) and LSB(7:0) bits based on the desired mode of operation.
- 5) Set the charge-pump clock division bits if the MAX9850 is not using the internal oscillator.

The **Auto Setup** button is intended to simplify user interaction by placing the EV kit into a known-good mode of operation.

MAX9850 Status/Interrupt

The MAX9850 EV kit software defaults to a state that continually polls the device for new status data and monitors the alert conditions. The contents of the status register are displayed in the **MAX9850 Status** group box (Figure 2). Changes in the GPIO state, PLL lock, headphones present, volume, and output overload can be set to trigger an interrupt by checking the checkbox next to the desired information.

To disable continuous polling of data, uncheck the **Automatic Status Read** checkbox (Figure 1). Force a manual status register read by clicking the **Read Status** button.

If an interrupt condition is generated, the message **INTERRUPT** appears next to the interrupt status label. If enabled, the program will disable automatic reading of the status register.

Status Bar

The status bar (Figure 3) displays the MAX9850 master clock, internal clock, and charge-pump clock frequencies. By default it is updated automatically; however, this feature can be turned off (see the *Clock Setup* section).

Headphone Control

The Headphones tab (Figure 1) allows access to the MAX9850 headphone-related controls.

Headphone volume can be adjusted in dB increments by adjusting the **Volume Control** slider. The dB increments are not evenly spaced and are detailed further in the MAX9850 data sheet. Alternatively, a number can be entered in the box below the **Volume Control** slider. If a number that does not match a predefined dB increment is entered, the software automatically rounds the number to the nearest valid dB increment and sends the appropriate I²C data to the MAX9850. Mute the HP output by selecting the **Mute** checkbox.

Additional headphone control is also provided through the **Headphone Features** box. **Slew Rate Control** is controlled through the respective check and drop-

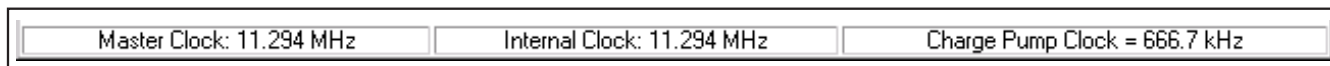

Figure 3. MAX9850 EV Kit Software Status Bar

MAX9850 Evaluation System/Evaluation Kit

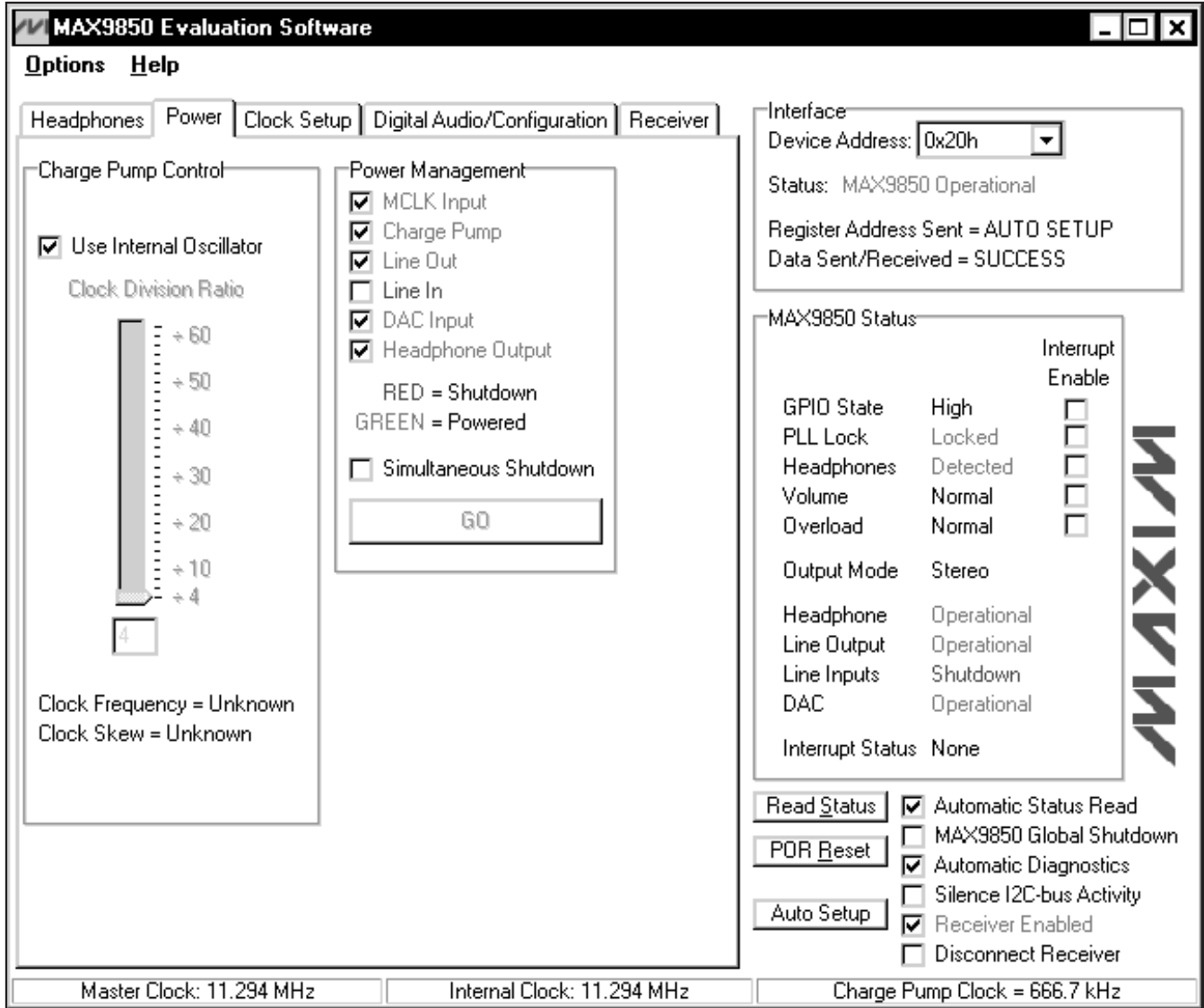

Figure 4. MAX9850 EV Kit Software Power Tab

down boxes. **Zero-Crossing Detection** and **Debounce Delay** are also controlled through the interface. For a detailed description of zero-crossing detection and debounce delay, refer to the MAX9850 data sheet. Clicking the **Force Headphone Mono Mode** checkbox mutes the right channel and outputs a left/right-channel mix on the left channel.

Power Management

Power-management features of the MAX9850 are accessed through the **Power** tab (Figure 4).

Power enables for the MCLK input, charge pump, line out, line in, DAC input, and headphone output are accessed through the **Power Management** box.

The MAX9850 charge pump can operate either an internal 666.7kHz oscillator or frequency derived from the master clock. Force the MAX9850 to use the internal oscillator by checking the **Use Internal Oscillator** checkbox. When the **Use Internal Oscillator** checkbox is unchecked, set the charge-pump clock divider by adjusting the **Clock Division Ratio** slider. Refer to the

MAX9850 Evaluation System/Evaluation Kit

Evaluate: MAX9850

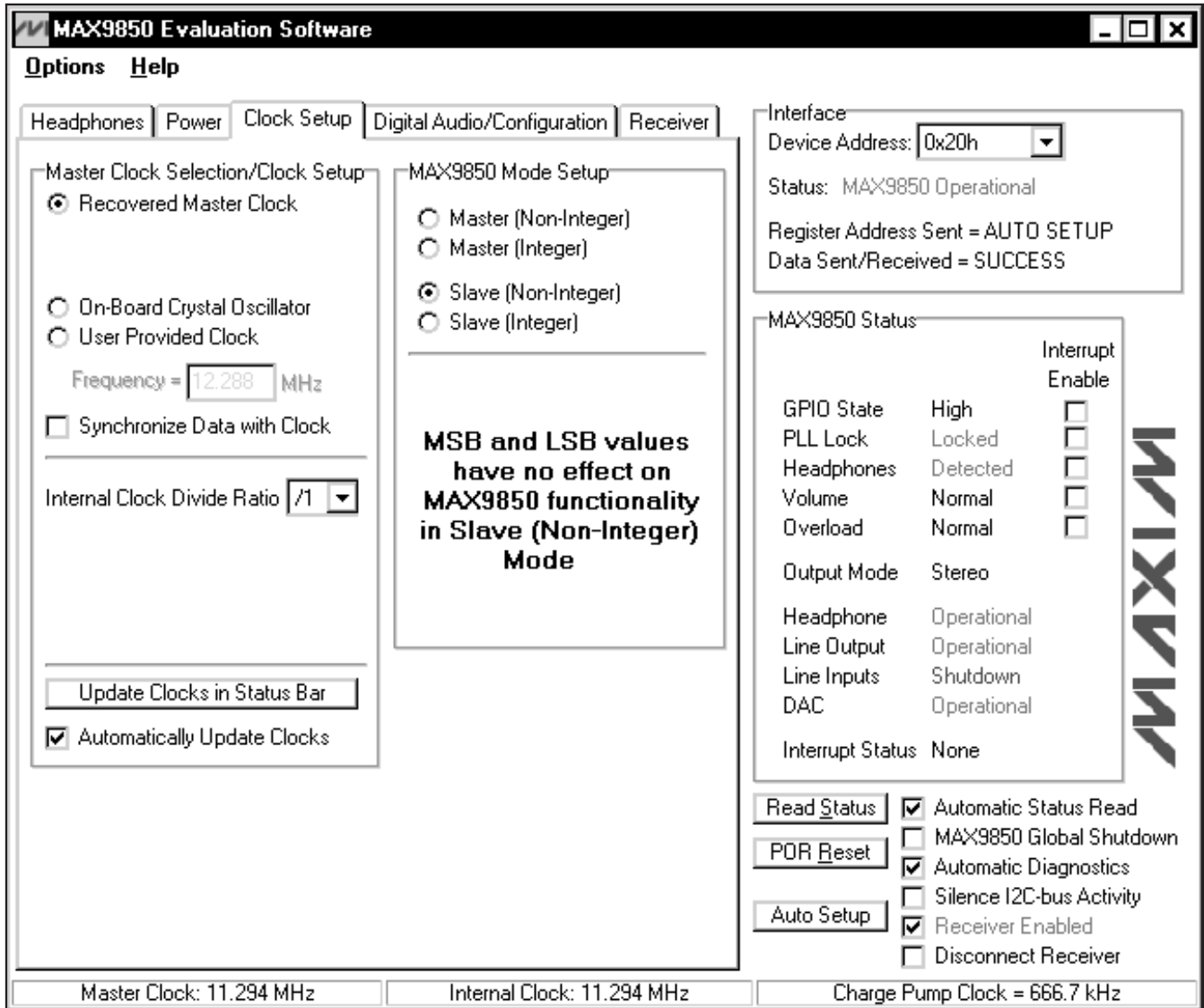

Figure 5. MAX9850 EV Kit Software Clock Setup Tab

MAX9850 data sheet for further details about clock-divider operation.

By default, the MAX9850 EV kit software writes to the registers when a control is activated. To shut down more than one item during the same I²C write operation, click the **Simultaneous Shutdown** checkbox. Adjust the other power-control checkboxes to the desired mode of operation and click the **GO** button. The proper register contents for the new selections will be sent in one I²C write command.

Clock Setup

Clock configuration features of the MAX9850 are accessed through the **Clock Setup** tab (Figure 5).

On-board multiplexers route a high-frequency square wave to the MAX9850 MCLK input. Select **Recovered Master Clock** to use the S/PDIF master clock. Select **On-Board Crystal Oscillator** to use the 12MHz crystal oscillator. Alternatively, a **User Provided Clock** can be applied to J9 of the MAX9850 EV kit. Enter the correct frequency in the **Frequency** box just below the **User**

MAX9850 Evaluation System/Evaluation Kit

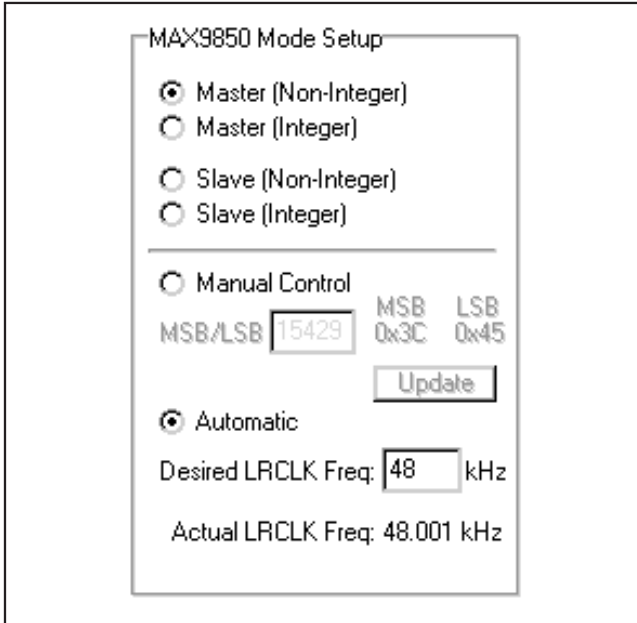

Figure 6. Master (Non-Integer) Mode

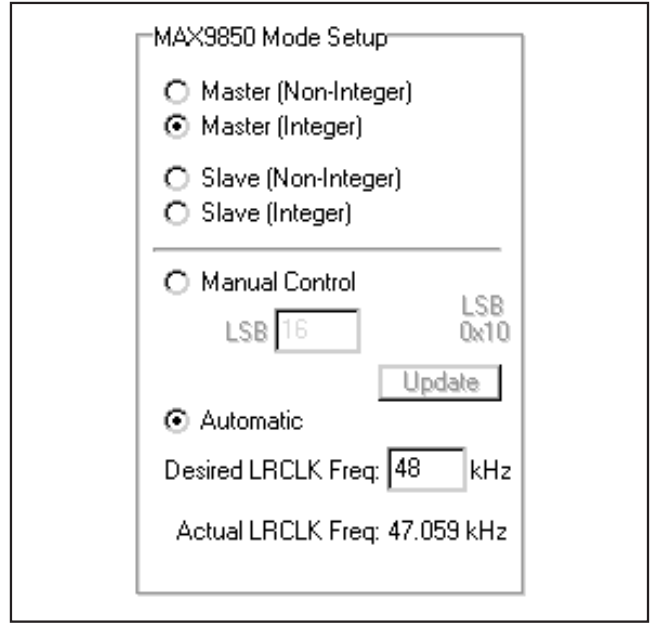

Figure 7. Master (Integer) Mode

Provided Clock selection. Depending on the desired mode of operation (see the *MAX9850 Mode Setup* section) digital audio data can be synchronized to the master clock signal. The on-board S/PDIF receiver performs the synchronization of the digital audio data to the chosen MAX9850 master clock signal. To synchronize the digital audio to the MAX9850 master clock, check the **Synchronize Data with Clock** checkbox.

Note: When using the **Recovered Master Clock** as the master clock frequency, the digital audio data will always be synchronized.

The MAX9850 uses a frequency-divided master clock signal throughout the IC (see the *MAX9850 Mode Setup* section). Select the desired internal clock-divider ratio from the **Internal Clock Divide Ratio** pulldown.

The MAX9850 EV kit software is capable of calculating the master clock, internal clock, and charge-pump clock frequencies. Press the **Update Clocks in Status Bar** button to display the calculated values. Checking the **Automatically Update Clocks** checkbox will update the calculated values on a regular basis.

MAX9850 Mode Setup

The **MAX9850 Mode Setup** window alters its appearance depending on which mode is selected. Figures 6–9 show the different appearances of these windows.

Both **Master (Non-Integer)** and **Master (Integer)** modes of the MAX9850 EV kit software (Figures 6 and

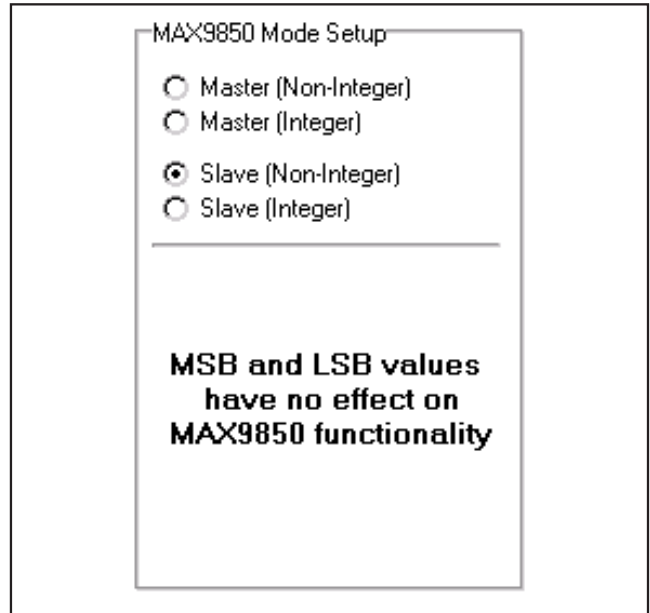

Figure 8. Slave (Non-Integer) Mode

7) are similar in operation. Select **Manual Control** to write directly to the MAX9850 registers. Enter the number in the **MSB/LSB** edit box in **Master (Non-Integer)** and **LSB** in **Master (Integer)** mode and press the **Update** button to write to the MAX9850. Alternatively, the **Automatic** mode can be selected and a desired

MAX9850 Evaluation System/Evaluation Kit

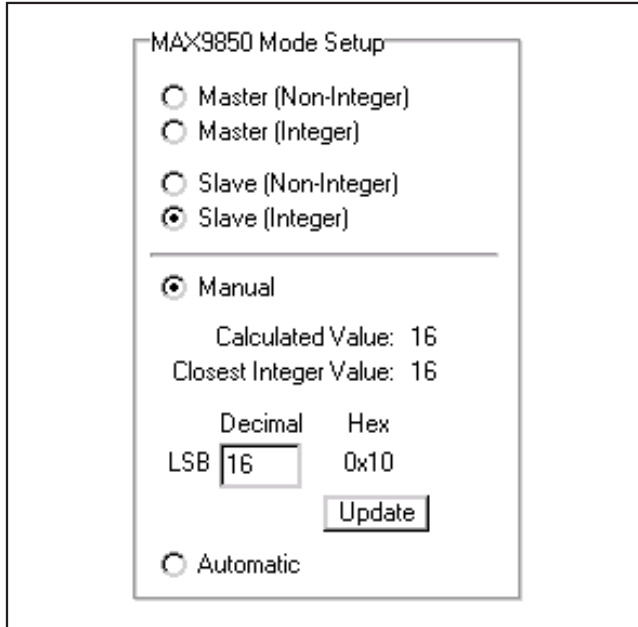

Figure 9. Slave (Integer) Mode

Left/Right Clock frequency can be entered into the **Desired LRCLK Freq** edit box. The EV kit software will automatically calculate the correct MSB/LSB values and write them to the MAX9850 registers.

The **Slave (Non-Integer)** mode (Figure 8) of the MAX9850 does not rely on the MSB or LSB registers for operation. **Slave (Integer)** mode (Figure 9) can be operated manually by entering a number in the **LSB** edit box. When using the **Automatic** mode, the MAX9850 EV kit software calculates the correct LSB value and writes it to the appropriate IC register.

Digital Audio/Configuration

Digital audio control and miscellaneous configuration options are accessed through the **Digital Audio/Configuration** tab (Figure 10).

In addition to a serial data delay, the MAX9850 can also accept an inverted bit clock (BCLK) or left/right clock (LRCLK). Configure the MAX9850 by checking the desired **Invert** or **Delay** checkboxes. Choose the desired **Data Format** and **Justification** from the pulldowns.

The MAX9850 EV kit software is designed to control both the on-board S/PDIF receiver chip as well as the MAX9850. To maintain a valid digital link between the two ICs, the MAX9850 EV kit software features a **Lock** checkbox in both the **Signals** and **Word Size** group boxes. When the **Signals/Lock** checkbox is checked, the EV kit software will ensure that **BCLK Invert**,

LRCLK Invert, **SDIN/OUT Delay**, and **Justification** settings for both the MAX9850 and the on-board S/PDIF receiver match. When the **Word Size/Lock** checkbox is checked, the EV kit software will ensure that the word size settings for both the MAX9850 and the on-board S/PDIF receiver match.

For example, if the **MAX9850 BCLK Invert** checkbox is altered, the MAX9850 EV kit software automatically changes the **Receiver BCLK Invert** checkbox to match. All appropriate I²C data will be sent to both ICs and the system will continue to function properly.

Note: Unchecking either of the lock checkboxes will allow the software to operate in a state that may not be functional. Undesirable results may occur.

The GPIO of the MAX9850 is also configured on this tab. Click the desired radio button to alter the **Pin Direction** or the **GPIO Output State**. To route the MAX9850 internal interrupt signal to the GPIO pin, check the **Enable Interrupt on GPIO** checkbox.

Receiver

The MAX9850 EV kit software also controls the on-board S/PDIF receiver. Receiver control and status are divided into two tabs.

Receiver Main Control

Receiver control is accessed through the **Main Control** sub-tab, which is located under the **Receiver** tab (Figure 11).

Choose the desired S/PDIF input (**Optical** or **Electrical**) in the **Digital Audio Input Selection** box. Mute the receiver output by checking the **Mute Receiver Output** checkbox. Activate the receiver's de-emphasis filter by choosing the desired option in the **Receiver De-Emphasis Filter** box. The on-board digital receiver features programmable error handling. Choose the desired method for handling S/PDIF errors in the **Audio Error Handling** box.

Receiver Status

Receiver status is accessed through the **Status** sub-tab, which is under the **Receiver** tab (Figure 12). This tab serves as an invaluable diagnostic tool when evaluating the MAX9850 EV kit.

Read the error status by clicking the **Read Status** button in the **Receiver Error Status** window. The **Monitor** checkboxes must be selected for the status bits to be valid.

Click the **Read Status** button in the **Status** box to read the receiver status. To have the software automatically read the receiver status at constant time intervals, check the **Automatic Read** checkbox.

MAX9850 Evaluation System/Evaluation Kit

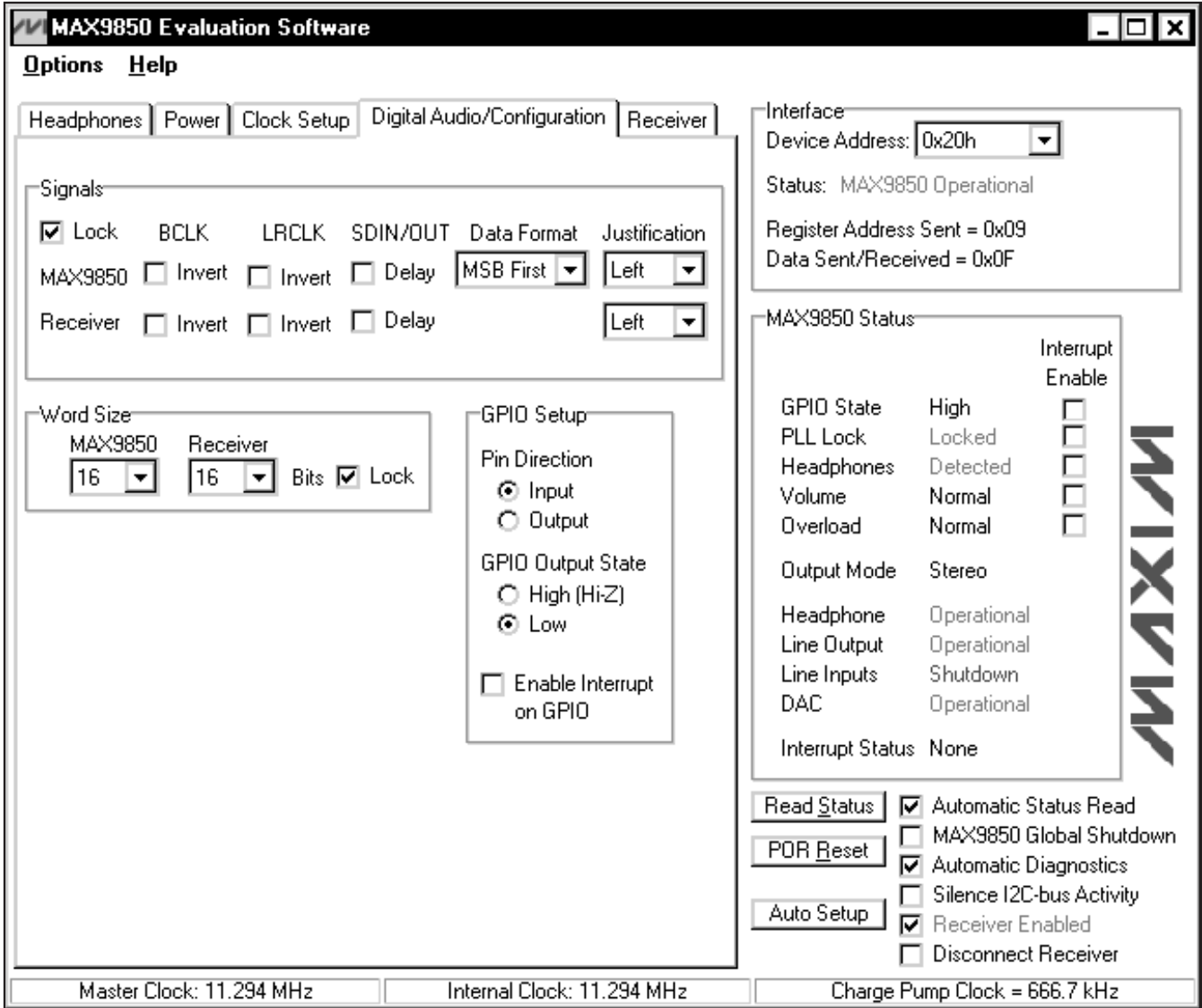

Figure 10. MAX9850 EV Kit Software Digital Audio/Configuration Tab

Simple I²C Commands

There are two methods for communicating with the MAX9850: through the normal user-interface panel or through the I²C commands available by selecting the **2-Wire Interface Diagnostic** item from the **Options** pull-down menu. A window is displayed that allows I²C operations, such as read byte and write byte, to be executed. To stop normal user-interface execution so that it does

not override the manually set values, turn off the update timer by deselecting the **Automatic Status Read** and **Automatic Diagnostics** checkboxes.

The I²C dialog boxes accept numeric data in binary, decimal, or hexadecimal. Hexadecimal numbers should be prefixed by \$ or 0x. Binary numbers must be exactly eight digits. See Figure 13 for an example of this control method.

MAX9850 Evaluation System/Evaluation Kit

Evaluate: MAX9850

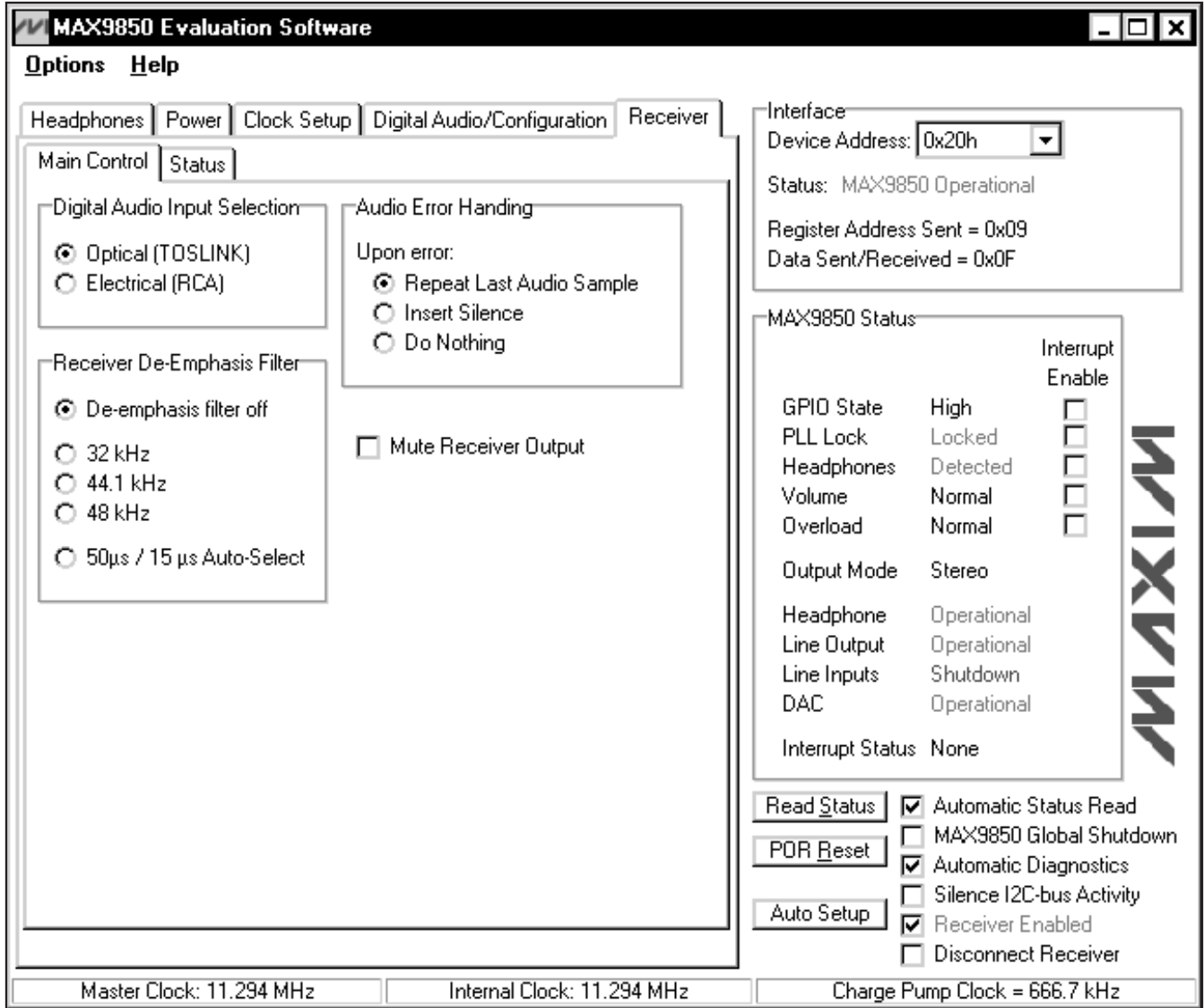

Figure 11. MAX9850 EV Kit Software Receiver (Main Control) Tab

Note: In places where the slave address asks for an 8-bit value, it must be the 7-bit slave address of the MAX9850 as determined by ADD with the last bit set to 1 for a read operation or a 0 for a write. Refer to the MAX9850 data sheet for a complete list of registers and functions.

Detailed Description of Hardware

The MAX9850 EV kit is a complete digital-audio headphone-driver evaluation system. The EV kit is driven by either an optical or electrical S/PDIF digital audio source. The S/PDIF signal is converted through on-board circuitry to compatible digital audio signals. The MAX9850 interfaces with the digital audio signals and drives a pair of headphones.

MAX9850 Evaluation System/Evaluation Kit

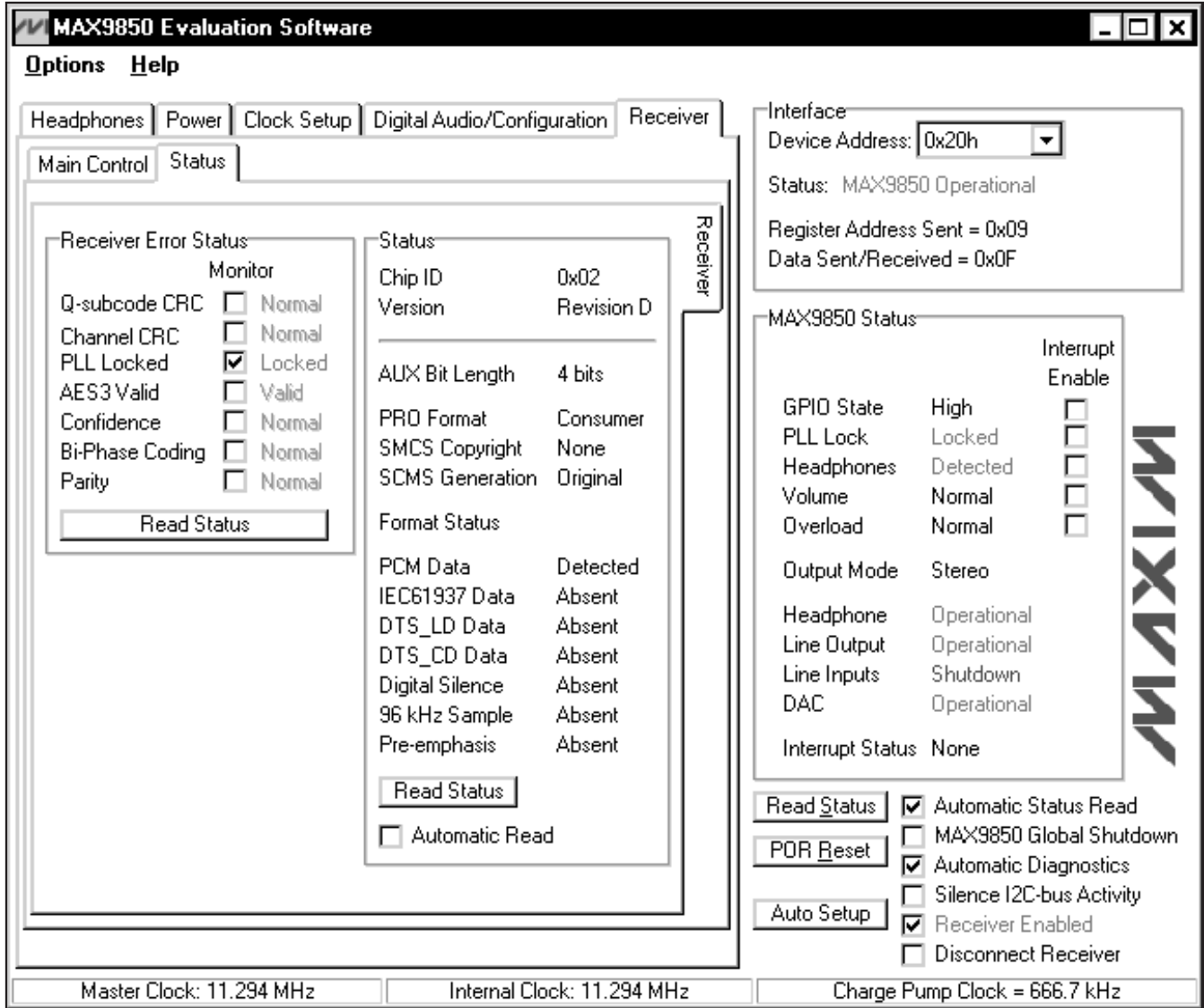

Figure 12. MAX9850 EV Kit Software Receiver (Status) Tab

Access to the MAX9850 analog inputs and outputs, is provided through RCA jacks J3–J6. Access the MAX9850 headphone outputs through the headphone jack J8 or the provided LEFT, RIGHT, and GND pads. The EV kit also features on-board level translators that allow the on-board S/PDIF receiver to communicate with the MAX9850 over the entire MAX9850 V_{DD} voltage range (1.8V to 3.6V). The CMOD232 command module powers half of the on-board level translators.

For optimum performance, digital audio systems require a stable frequency source. The MAX9850 EV kit features an on-board 12MHz crystal oscillator. In addition, the MAX9850 EV kit can also use a user-provided signal source that is connected to J9. Alternatively, the S/PDIF recovered clock can be used. The MAX9850 ev kit software controls which clock signal is routed to the MCLK input (see the *Clock Setup* section for more details).

MAX9850 Evaluation System/Evaluation Kit

Evaluate: MAX9850

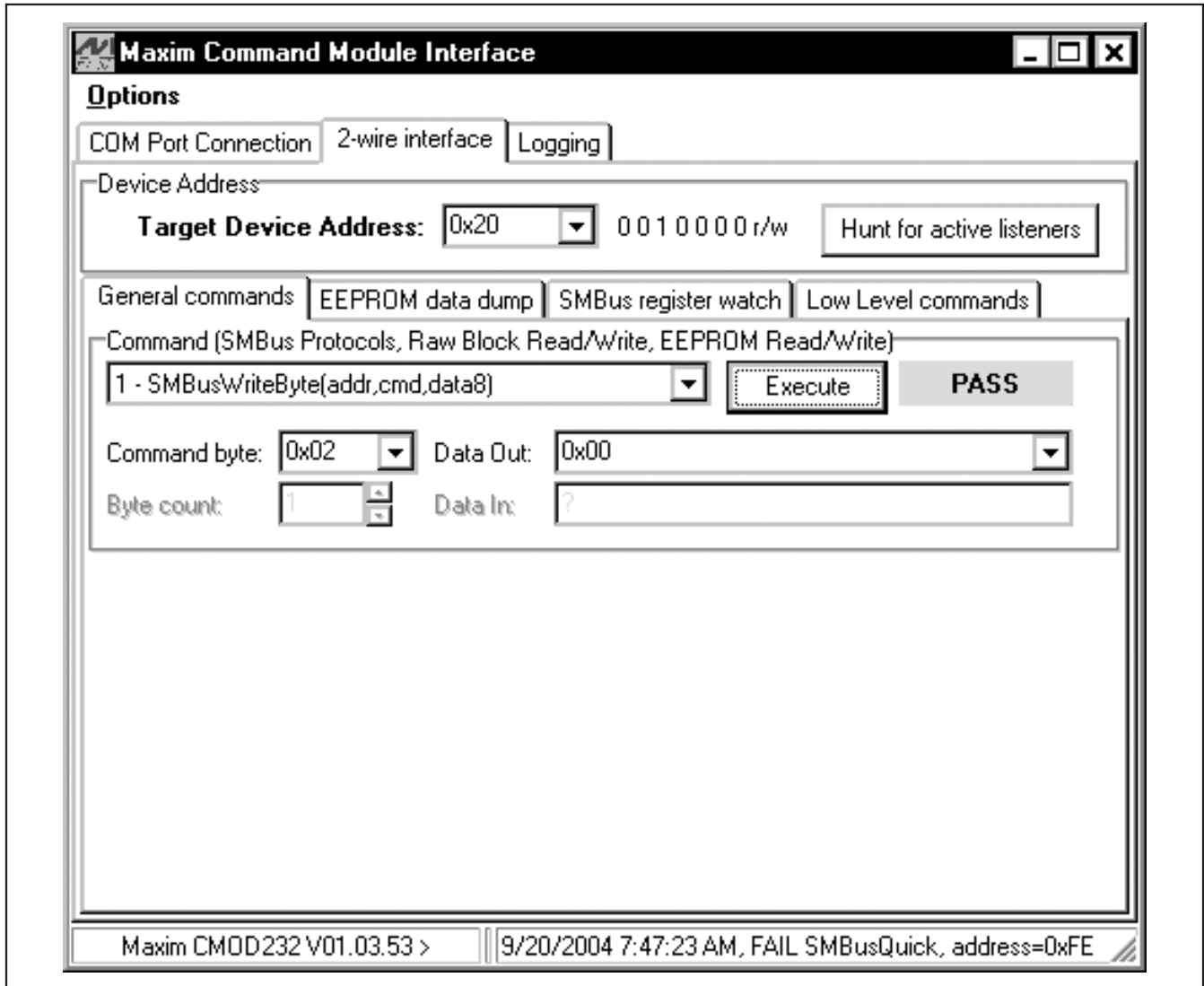

Figure 13. The above example shows a simple SMBusWriteByte operation using the included Two-Wire Interface Diagnostics. In this example, the software is writing data (0x00h) to Device Address 0x20h, Register Address 0x02h. The above data sequence will set the volume of the MAX9850 to max.

Address Selection

Jumper JU1 sets the MAX9850 I²C slave address. The default address is 0010 000Y (ADD = GND). See Table 1 for a complete list of addresses.

Note: The first 7 bits shown are the address. Y (bit 0) is the I²C read/write bit. This bit is a 1 for a read operation or a 0 for a write.

Manual Headphone Sense Control

To simulate a pair of headphones being inserted into the headphone jack J8, remove the shunt from jumper JU2. Connect the load to the LEFT, RIGHT, and GND pads located by the headphone jack J8. See Table 2 for jumper settings.

MAX9850 Evaluation System/Evaluation Kit

Table 1. JU1 Shunts Settings for I²C Address (JU1)

SHUNT POSITION	MAX9850 ADDRESS PIN	MAX9850 ADDRESS	
		BINARY	HEXADECIMAL
1-2*	GND	0010 000Y	0x20h
3-4	AVDD	0010 001Y	0x22h
5-6	SDA	0010 011Y	0x26h

*Default Configuration: JU1 (1-2)

Table 2. Manual Headphones Sense Control (JU2)

SHUNT POSITION	DESCRIPTION
Installed*	MAX9850 EVKIT headphone sense controlled by the insertion of headphones.
Not Installed	MAX9850 EVKIT headphone sense switch forced open.

*Default Configuration: JU2 (Installed)

Table 3. GPIO Pullup Register (JU3)

SHUNT POSITION	DESCRIPTION
1-2*	GPIO pin pulled up to 3.3V. Monitor GPIO signal at the GPIO pad.
2-3	GPIO pin left open. Connect a pullup resistor to the desired voltage. Monitor GPIO signal at the GPIO_OPEN pad.

*Default Configuration: JU3 (1-2)

GPIO Interface

The MAX9850 EV kit features an on-board pullup resistor on the MAX9850 GPIO pin. Jumper JU3 can disconnect this pin from the pullup resistor.

Using an Alternative I²C Interface

The MAX9850 EV kit provides pads and pullup resistor placeholders that allow an alternative I²C-compatible interface to be used. Connect the interface through the SCL, SDA, and GND pads. Install pullup resistors at positions R7 and R8, if required.

If the on-board digital receiver IC is to be used with an alternative I²C interface, connect a 3.3V power supply between the VMOD and GND pads on the MAX9850 EV kit. The I²C address of the digital receiver is fixed at 0x28.

Using an Alternative Digital Audio Interface

The MAX9850 EV kit features a digital receiver that converts readily available S/PDIF signals to the required digital audio signals needed for the MAX9850. If an alternative digital audio interface is to be used, connect the interface to header J10, check **Disconnect Receiver**. Header pin names are clearly marked on the EV kit silkscreen. Ensure that the command module is disconnected from the EV kit during this mode of operation.

Synchronizing the EV Kit (Master Modes)

While in master mode, the MAX9850 supplies the LRCLK signal and thus controls the digital audio sample rate. To allow synchronization between the MAX9850 and the S/PDIF sample source, the LRCLK signal is buffered and output to a set of pads on the EV kit. Connect the synchronization input of the S/PDIF sample source to the LRCLK and GND pads (Figure 14). The LRCLK signal is 3.3V CMOS compatible.

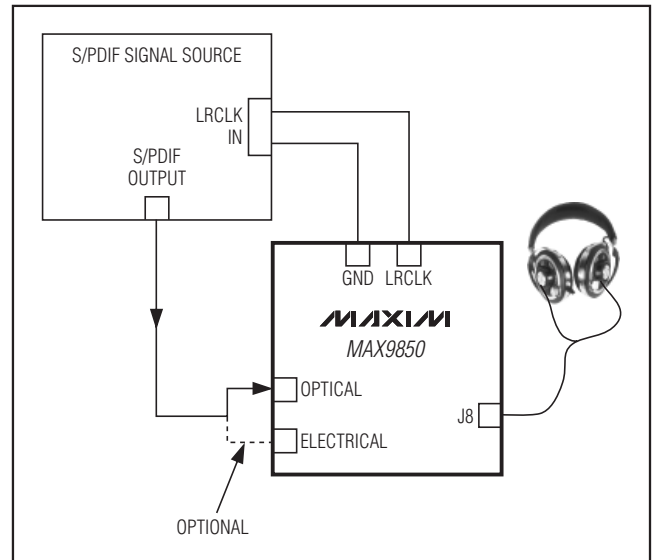

Figure 14. Synchronized MAX9850 EV Kit Diagram

MAX9850 Evaluation System/Evaluation Kit

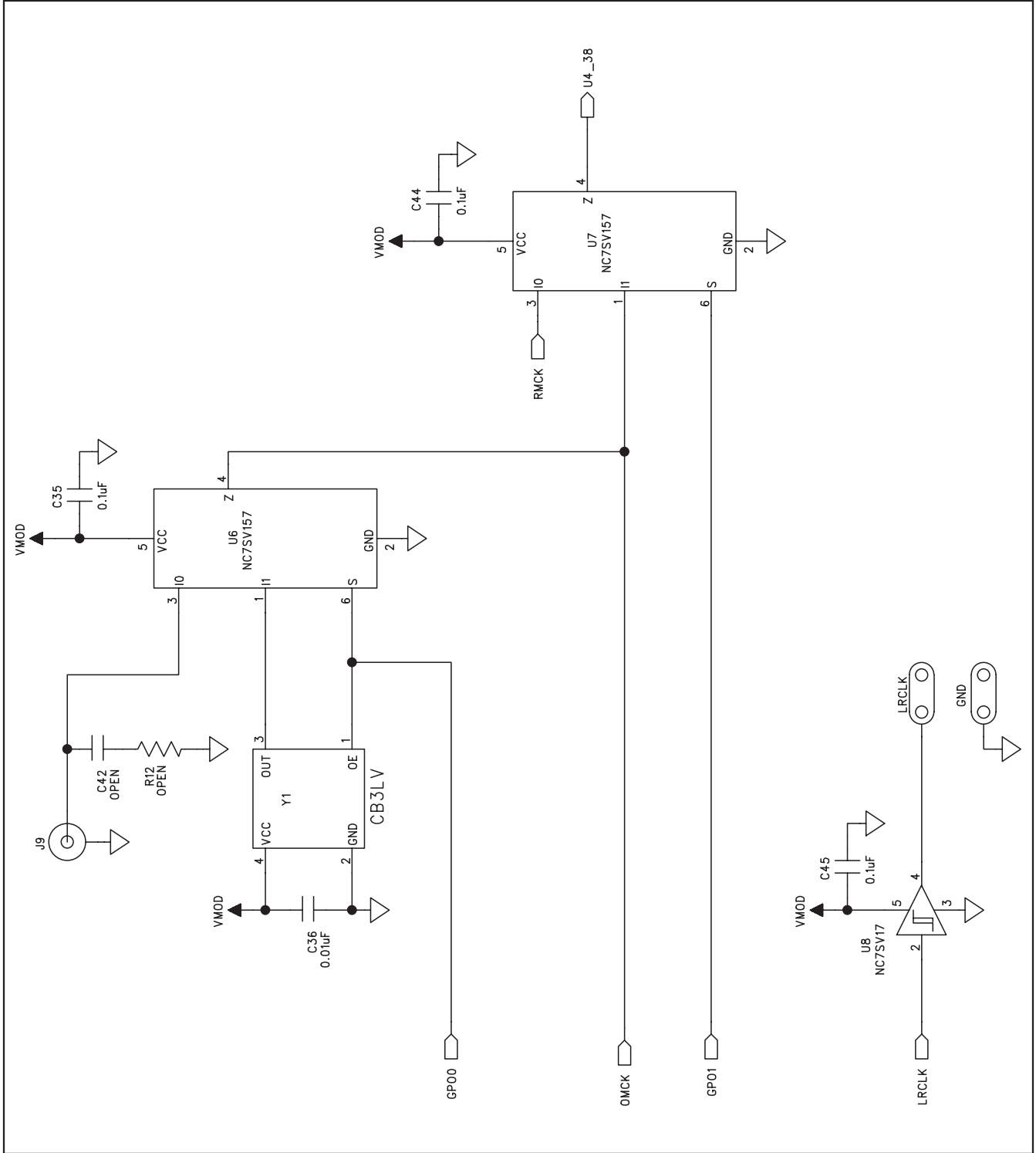

Figure 15b. MAX9850 EV Kit Schematic (Sheet 2 of 2)

MAX9850 Evaluation System/Evaluation Kit

Evaluate: MAX9850

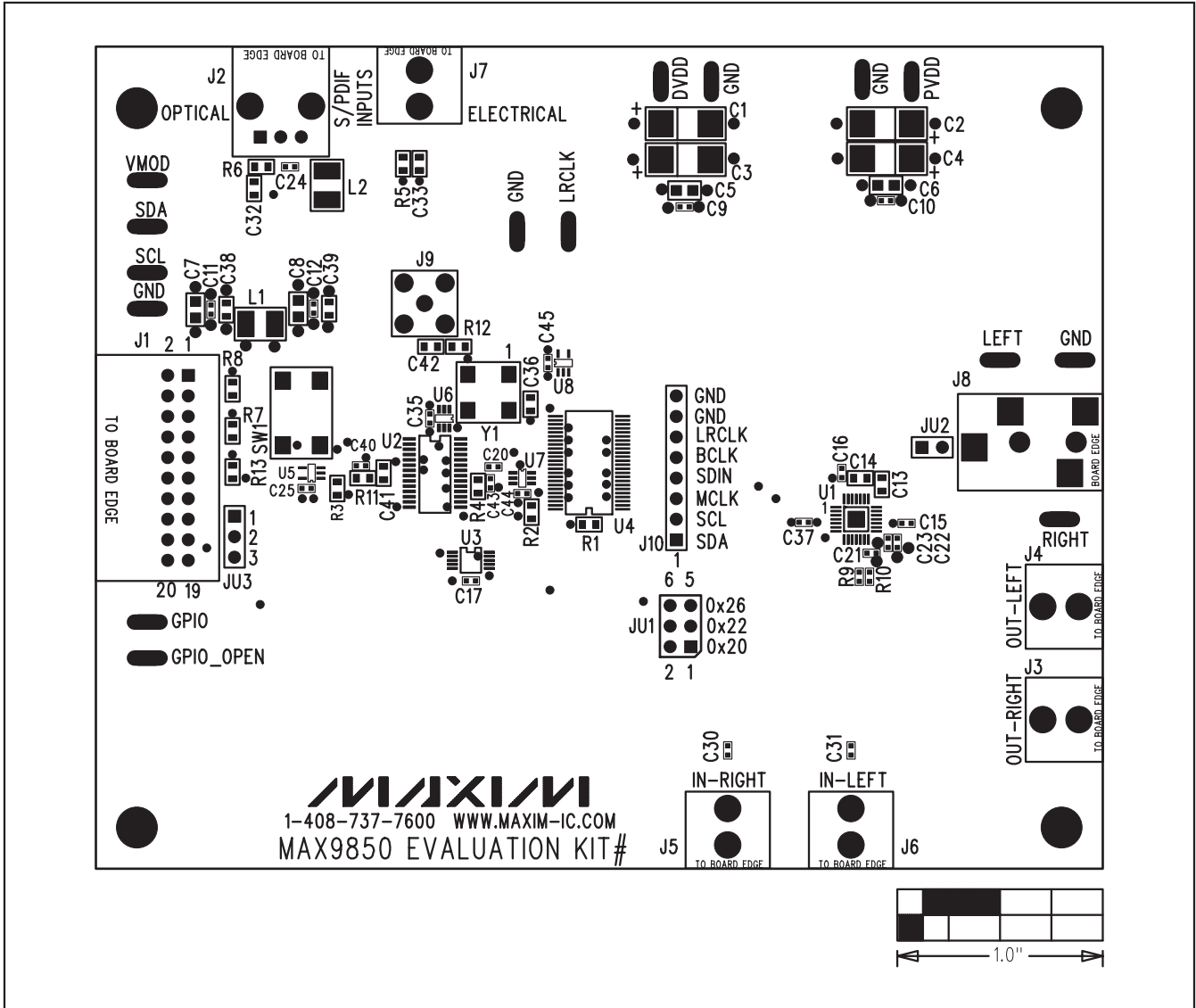

Figure 16. MAX9850 EV Kit Component Placement Guide—Component Side

MAX9850 Evaluation System/Evaluation Kit

Evaluate: MAX9850

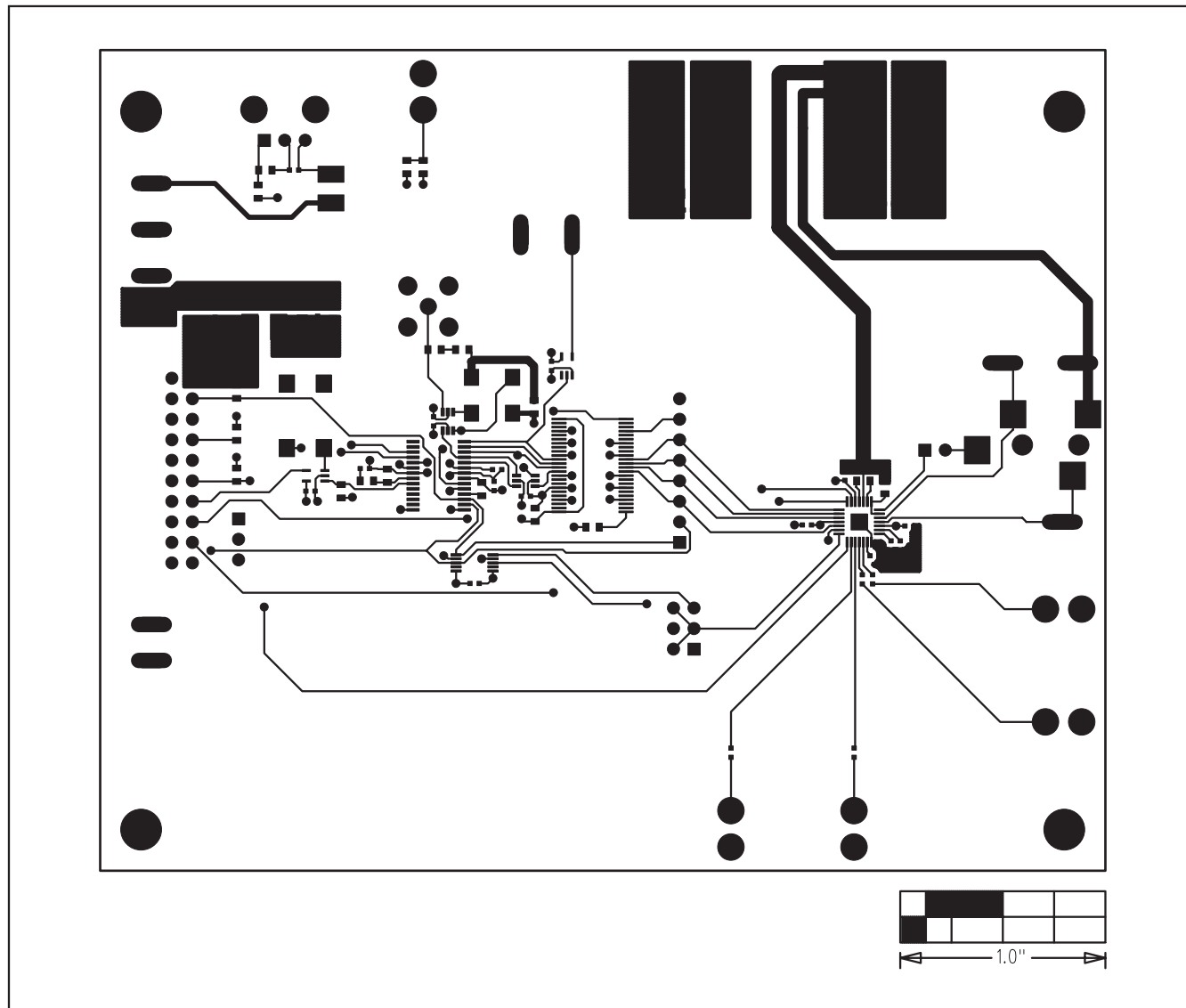

Figure 17. MAX9850 EV Kit PCB Layout—Component Side

MAX9850 Evaluation System/Evaluation Kit

Evaluate: MAX9850

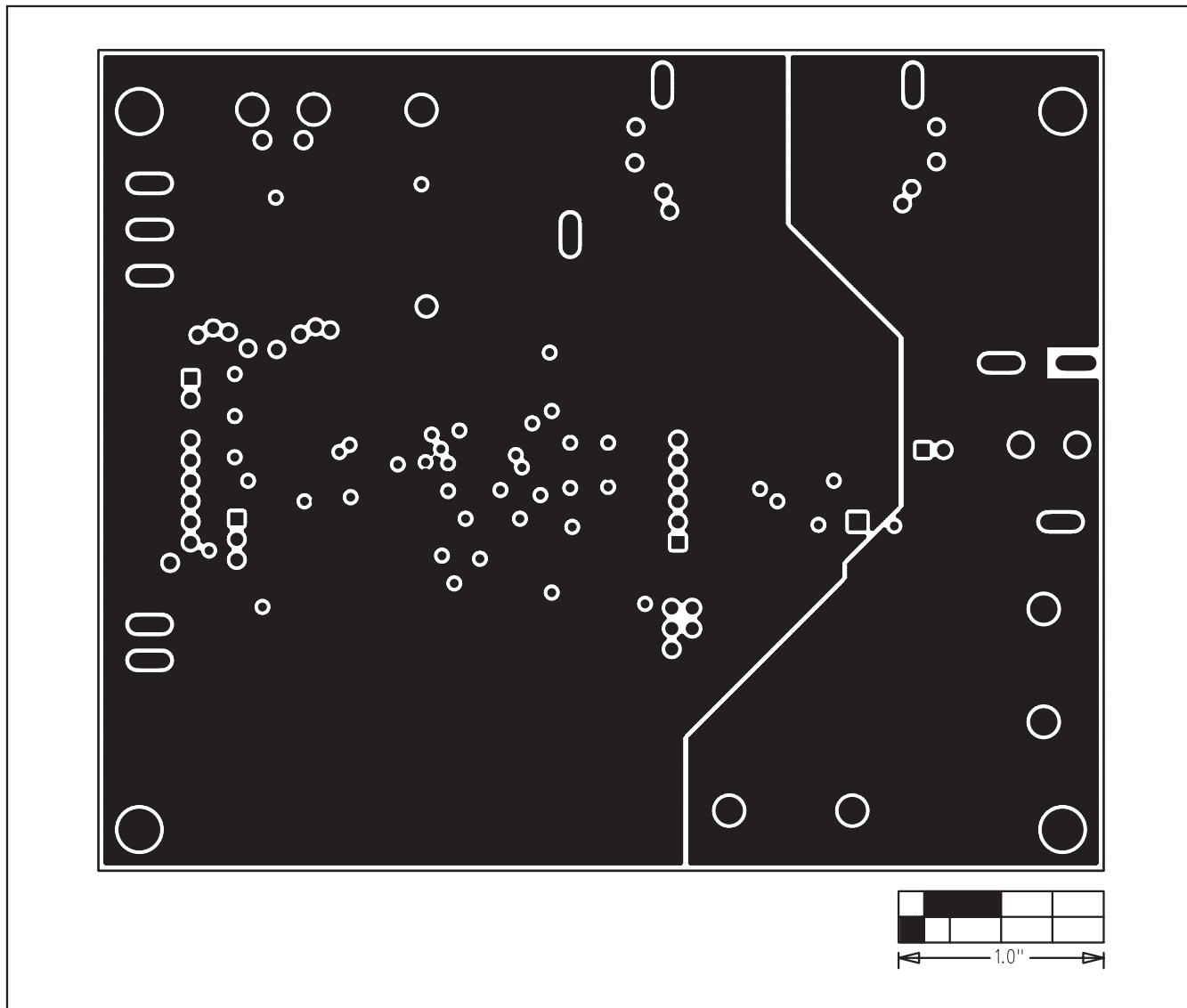

Figure 18. MAX9850 EV Kit PCB Layout—Inner Layer 2

MAX9850 Evaluation System/Evaluation Kit

Evaluate: MAX9850

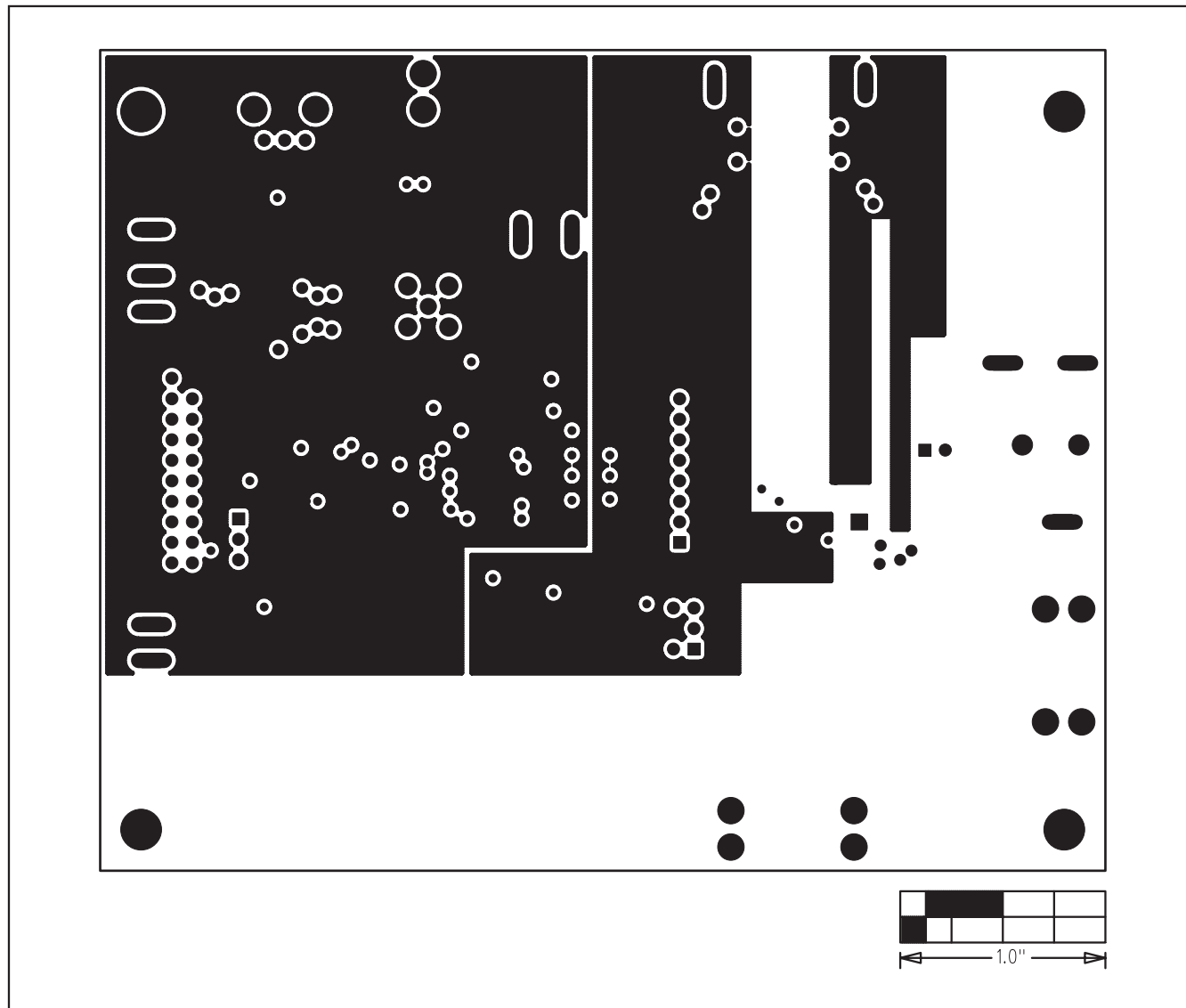

Figure 19. MAX9850 EV Kit PCB Layout—Inner Layer 3

MAX9850 Evaluation System/Evaluation Kit

Evaluate: MAX9850

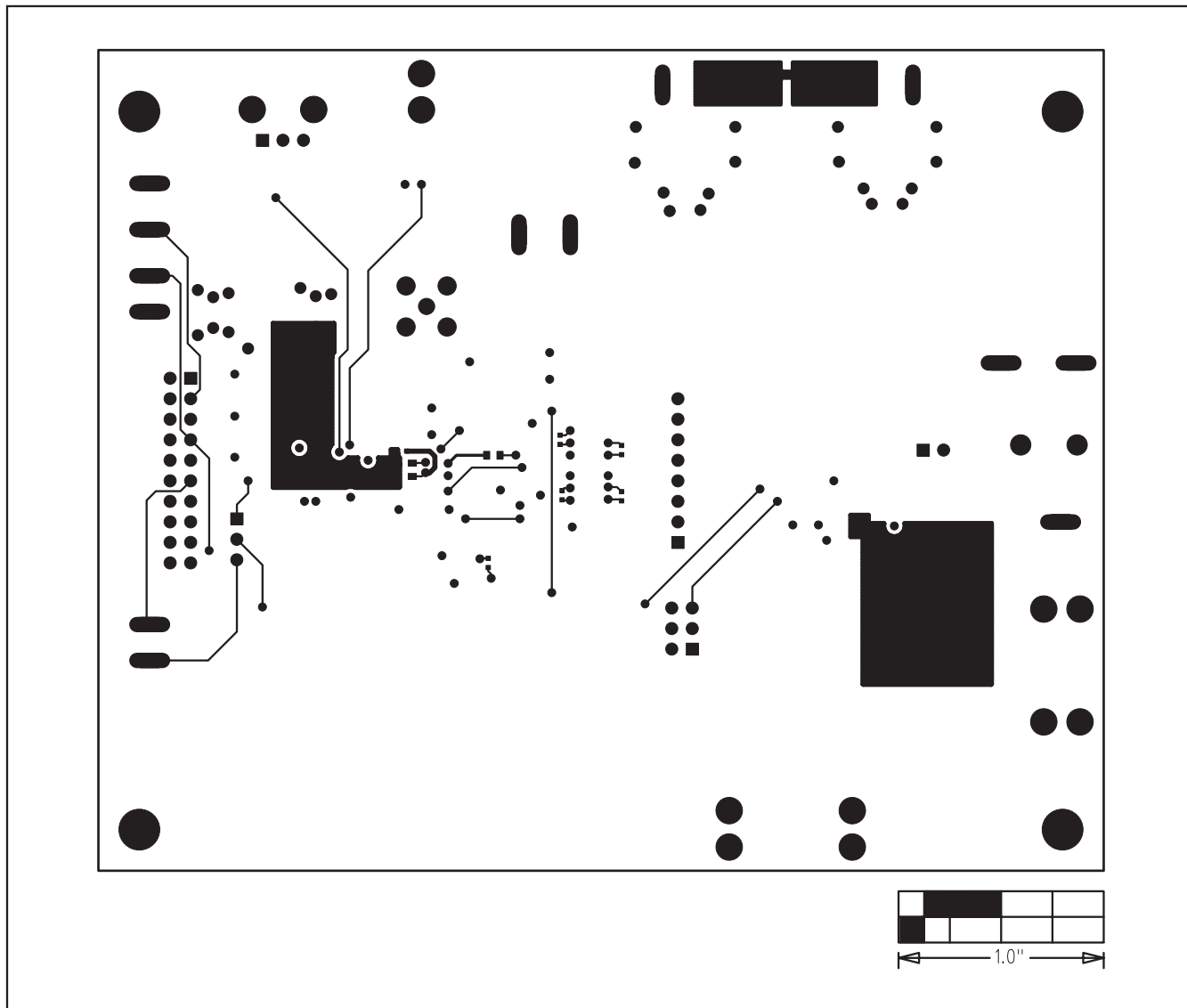

Figure 20. MAX9850 EV Kit PCB Layout—Solder Side

MAX9850 Evaluation System/Evaluation Kit

Evaluate: MAX9850

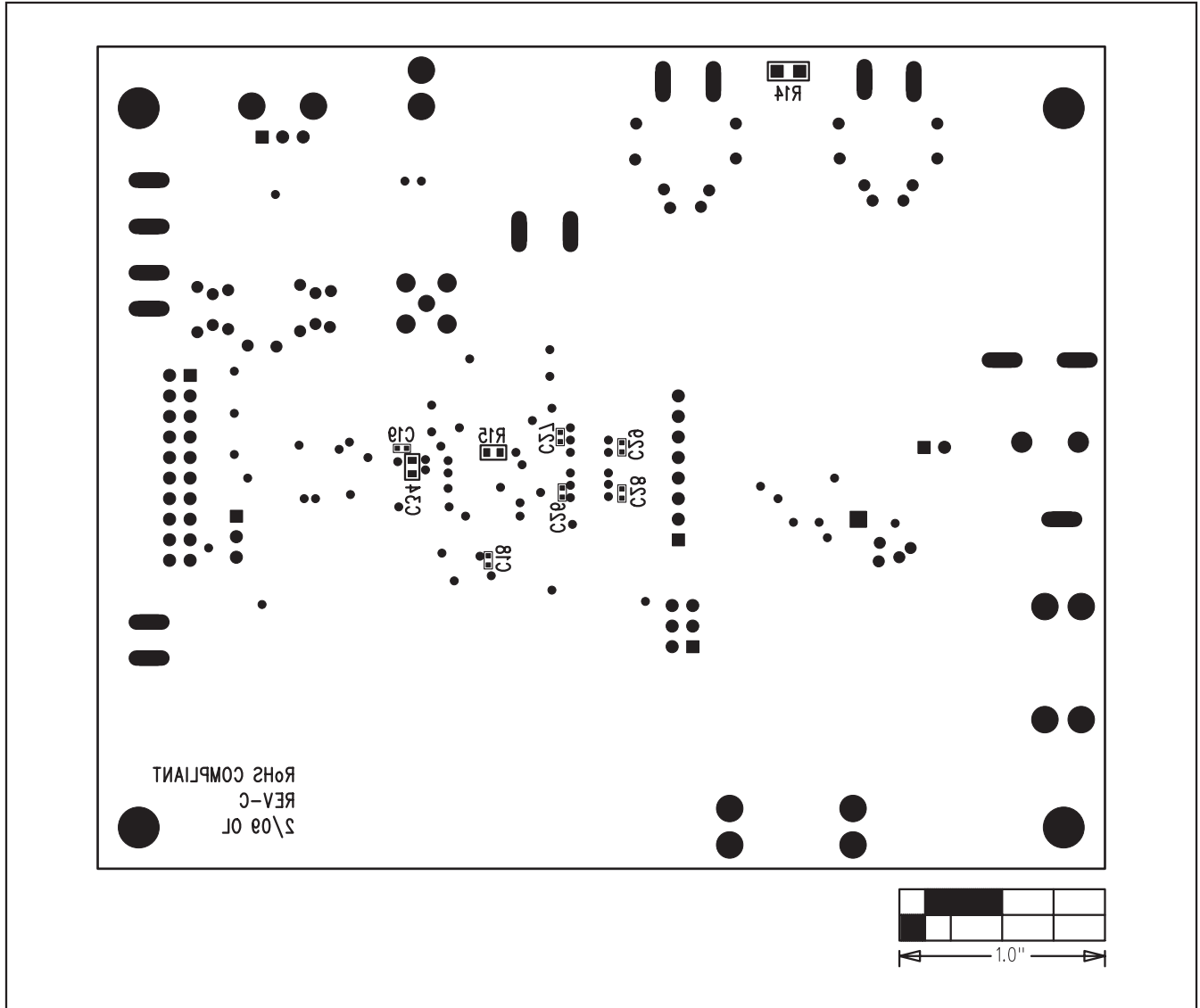

Figure 21. MAX9850 EV Kit Component Placement Guide—Solder Side