

Evaluates: MAX9959

MAX9959 Evaluation Kit

General Description

The MAX9959 evaluation kit (EV kit) is a fully assembled and tested printed circuit board (PCB)

design that evaluates the functionality of device power supply (DPS) IC MAX9959, which has 25V span output voltage and programmable current ranges up to 800mA.

The MAX9959 EV kit contains a microcontroller (MCU) that translates between the SPI interface and USB to allow the user to configure internal registers and modes with graphical user interface (GUI) software running on a PC. The EV kit includes Windows® 10-compatible software that provides a simple GUI for configuration of all the MAX9959 registers through SPI. The EV kit is fully assembled and tested at the factory.

This document provides a list of equipment required to evaluate the device, a straightforward test procedure to verify functionality, a description of the EV kit circuit, component list, circuit schematic, and artwork for each layer of the PCB. The MAX9959 EV kit PCB comes with a MAX9959DCCQ+ installed.

Benefits and Features

- Easy Evaluation of the MAX9959 EV kit
- On-Board Voltage Reference (MAX6126)
- On-Board DACs for Level Setting
- On-Board ADC for Measurements
- On-Board Regulators Generate All the Required Voltages from $\pm 12V$
- USB Interface
- Headers for External SPI and DACs
- Proven PCB Layout
- Includes Heatsink and Fan
- Fully Assembled and Tested

Quick Start

Required Equipment

This section lists the recommended test equipment to verify operation of the MAX9959. It is intended as a guide only and substitutions are possible.

- MAX9959 EV kit
- Windows PC (Windows 10) with one USB2.0 port
- Triple Output DC power supply
 - +12V/1.5A
 - -12V/1.5A
 - +5V/500mA
- Digital voltmeter and ammeter

Software and Drivers

The MAX9959 EV kit is used in conjunction with the ARM Cortex-M4F microcontroller MAX32625PICO Application Platform or “PICO” board to provide power and control the device through a software application or GUI.

Install the MAX9959 EV Kit GUI Software

This process should take less than 10 minutes after downloading the software package.

- Download the MAX9959 EV kit software from the Maxim Integrated website, run the installation file, and install it
- Start running the GUI program

[Ordering Information](#) appears at end of data sheet.

Procedure

This section provides a step-by-step guide to operating the EV kit and testing the device functions.

Caution: Do not turn on the DC power until all connections are completed. Connect all power-supply grounds to a single ground terminal.

- 1) Place the MAX9959 EV kit on a nonconductive surface to ensure that nothing on the PCB gets shorted to the workspace.
- 2) Set all jumpers in their default position as mentioned in [Table 1](#).
- 3) Connect the USB cable from PC to EV kit.
- 4) Apply +12V to VCC, -12V to VEE, and +5V to VDD.
- 5) Start the MAX9959 EV kit software by opening its icon in the **Start | Programs** menu. The EV kit software main window should appear, as shown in [Figure 1](#).
- 6) In the **MAX9959 Settings** group box, click on the **FV** radio button in the **Measurement Mode** group box and click the **Write** button.
- 7) In the **DAC Settings** group box, change the voltage for VIN to +1V and click the **Write** button.
- 8) Check that the output voltage at DUT_NODE is close to +1V. [Figure 1](#) shows the MAX9959 EV kit quick start settings.

Detailed Description

Detailed Description of Software

The main window of the evaluation kit software is shown in [Figure 1](#).

The MAX9959 GUI is organized into four group boxes for all level setting registers and control signal settings, along with the **File** menu to save and load all these settings.

MAX9959 Settings

The MAX9959 can be quickly configured through control register settings. An 18-bit word programs the MAX9959.

The **Measurement Mode** group box is a quick way to set the MAX9959 to force voltage (FV), force current (FI), force current as a slave device (FI Slave), or place into high impedance (Hi-Z). Bit settings are automatically changed to match the mode settings as follows:

- In **Hi-Z mode**, all the bits in control register are unchecked.
- In **FI Slave** mode, FMODE bit is checked and all other bits are unchecked.
- In **FV mode**, $\overline{\text{HIZFRCB}}$ bit is checked and all other bits are unchecked.
- In **FI mode**, both $\overline{\text{HIZFRCB}}$ and FMODE bits are checked and all other bits are unchecked.

The **Measurement Mode** group box provides the measured voltages at IMEAS and VMEAS pins of the MAX9959. [Table 1](#) shows the settings and functionality of these bits in the GUI:

Table 1. Settings and Functions of the GUI Bits

SETTING	FUNCTION
VGA Gain	This horizontal scrollbar controls the gain and polarity of the variable gain amplifiers (VGA).
Range	This horizontal scrollbar controls the full-scale current range for either FI (force current) or MI (measure current) mode.
FMODE	This checkbox selects DPS mode (FV, FI, FI slave, and Hi-Z).
CLEN	This checkbox enables or disables the voltage and current clamps.
$\overline{\text{HIZFRCB}}$	This checkbox along with FMODE selects DPS mode (FV, FI, FI slave, and Hi-Z).
$\overline{\text{HIZMSB}}$	This checkbox controls the measure output's high-impedance state.
$\overline{\text{HIZCMPB}}$	This checkbox controls the comparator output's high-impedance state.
LCOMP1 and LCOMP0	These checkboxes enable or disable compensation capacitors.
BCOMP1 and BCOMP0	These checkboxes enable or disable bypass capacitors.

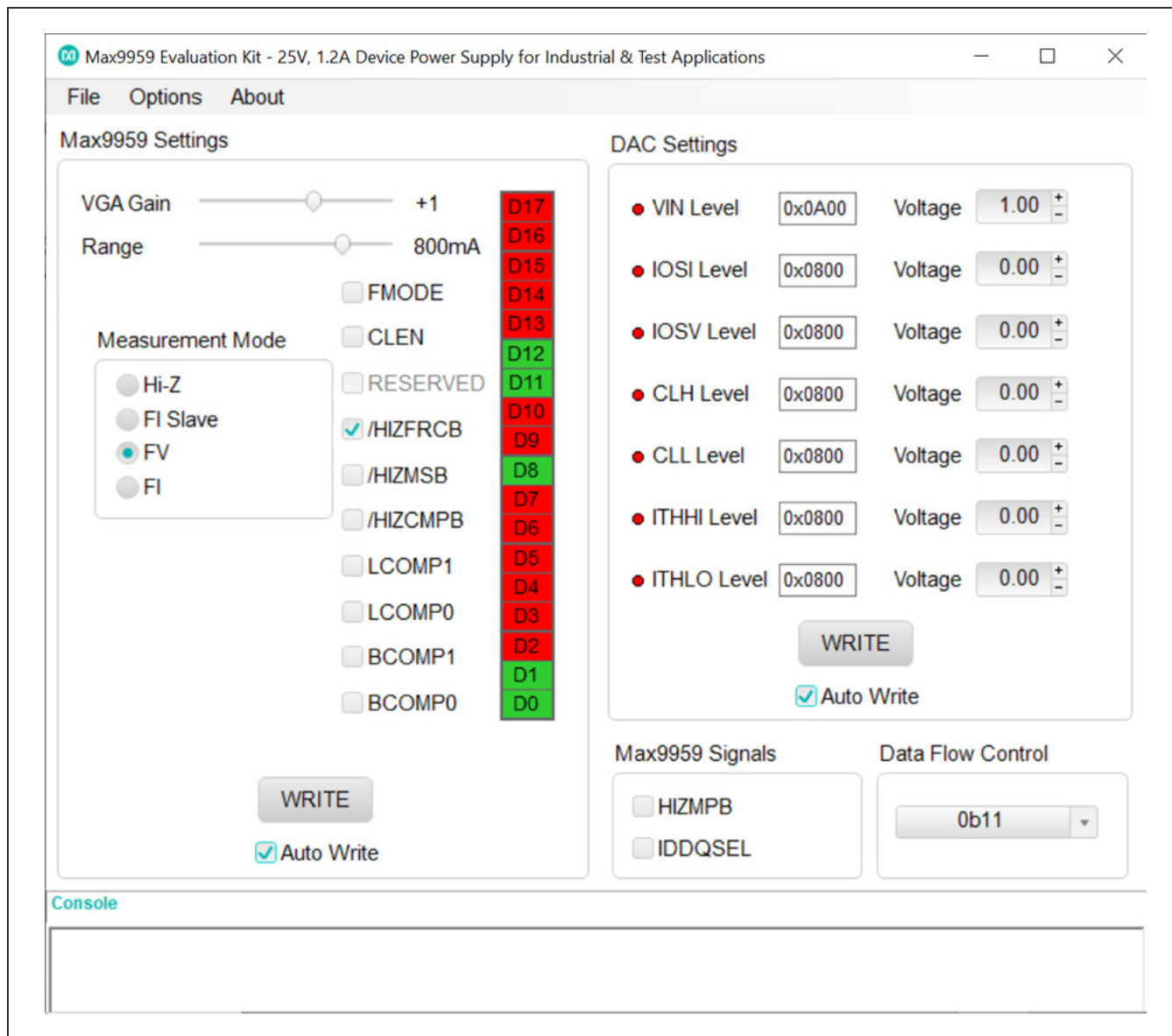

Figure 1. MAX9959 EV Kit Quick Start Settings

MAX9959 Signals and Data Flow Control

HIZMPB and IDDQSEL are signals that can be used to control the functionality of the MAX9959. The HIZMPB signal is shared in functionality with the HIZMSB bit, and internally both bits are ANDed. It is used either to enable the measurement output or to put the measurement output in the high-impedance state. While in FV mode asserting digital input, IDDQSEL switches the DPS to the

minimum current range (range D) and enables the IDDQ test mode.

Data flow control bits specify how data transfers from the shift registers to the input and DPS register of the MAX9959. Refer to *Serial Interface Data Flow Control Bits* section in the MAX9959 data sheet for more details. [Table 2](#) shows the options available for controlling the data flow.

Table 2. Data Flow Control Settings

SETTING	DESCRIPTION
00	Input and DPS registers remain unchanged
01	DPS registers get loaded from input register
10	Input registers get loaded from shift register
11	Both DPS and input registers get loaded from shift register

DAC Settings

The MAX5322 is a two channel DAC, and four of them are used to provide seven input voltages for the MAX9959 device. The output voltages are set by entering values in the corresponding edit boxes and pressing **Enter** on the keyboard or clicking the **Write** button in this specific group box. The edit boxes accept the value of the voltage. Changes in the **DC Level** edit boxes automatically change the hexadecimal values in the **DAC Setting** edit boxes and vice versa. Analog voltages (VIN, IOSI, IOSV, CLH, CLL, ITHHI, and ITHLO) are set by the MAX5322 and appear as the input levels for the MAX9959.

AutoWrite

The **AutoWrite** checkboxes can be checked to have the software automatically perform write operations. This feature allows the user to change settings and have them updated without clicking the **WRITE** buttons. There is an **AutoWrite** checkbox for writing to the MAX9959 and DACs. Each device can independently perform autowriting. **AutoWrite** is disabled by default.

Menu Options

The **Save Configuration** option in the **File** menu saves the current configuration in the MAX9959 EV kit software and the **Load Configuration** option in the **File** menu

loads the saved configuration in the MAX9959 EV kit software. The **Save Log** option in the **File** menu saves the data log in the console of the MAX9959 EV kit software.

The **Select Port** in the **Options** menu enables the user to connect to the desired COM port. The **Reset Settings** in the **Options** menu resets all the current settings in the MAX9959 EV kit software.

Detailed Description of Hardware

The MAX9959 EV kit is a fully assembled and tested circuit board for evaluating the MAX9959 device power supply. The MAX5322 DAC provides the analog voltages to the MAX9959 DPS. The MAX32625PICO microcontroller controls SPI data transfer to both MAX9959 DPS and MAX5322 DACs. The various test points are available for different signals and LEDs to indicate status information. The EV kit uses banana plugs for the outputs and inputs because of their high-current capability. A fan header is provided to power up the fan and cool the MAX9959 DPS. Operating without the fan does not damage the MAX9959 DPS even at high current because it has a thermal shutdown feature that turns off the IC when the die temperature exceeds the thermal limit. The thermal limit is reached quickly without airflow from the fan. [Figure 2](#) shows the block diagram of the MAX9959 EV kit.

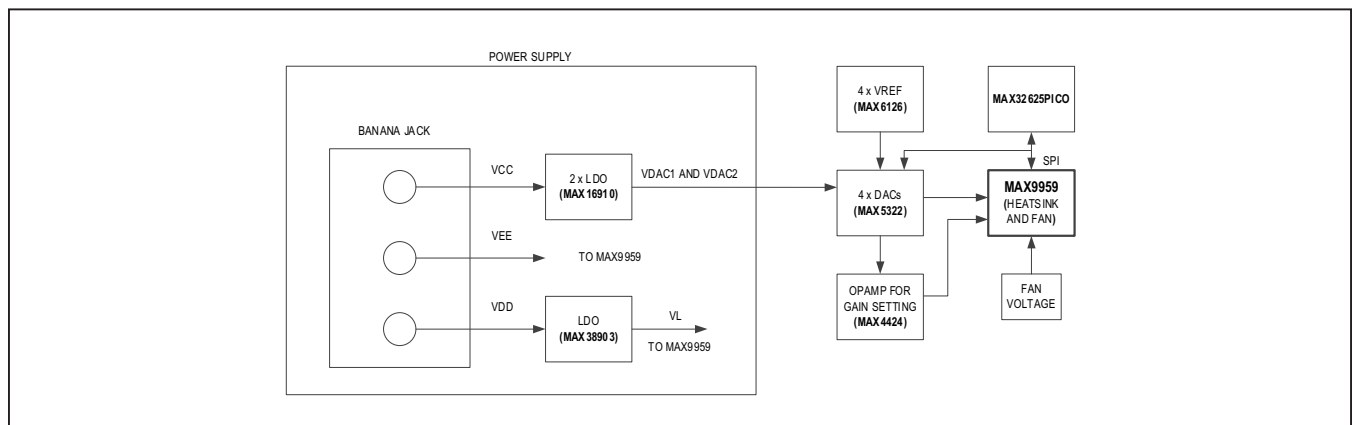

Figure 2. MAX9959 EV Kit Block Diagram

Power Supplies

Connect the power supplies using the high-current banana jacks, VEE (-12V), VCC (+12V) and VDD (+5V). The GND banana jack should be common for all the power supplies on the MAX9959 EV kit. All power supplies should be within the range specified in the MAX9959 IC data sheet.

The MAX9959 EV kit needs only three supplies to be connected to the board; all other supplies are generated through regulators on the EV kit board.

Jumper Settings

Table 3 shows the jumper header, shunt position, and description.

Table 3. Jumper Settings

JUMPER	SHUNT POSITION	DESCRIPTION
J1	Open*	Connects SENSE to DUT_NODE
J2	Open*	Connects DUTGSNS to GND
J3	Open* 4	Connects VTHR to GND
J4	Open*	Provides various signals (AMPOUT, IPAR, VINS, EXTSEL, and VTHR) on the header for external connection
J5	1-2*	Turns on the fan on heatsink
JU12	2-3	Turns off the fan on heatsink
J6	Open*	Connects to 5V supply of fan
J7	1-2*	Connects VCC from power jack to VCC of the MAX9959
J8	1-2*	Connects VEE from power jack to VEE of the MAX9959
J9	1-2*	Connects VDD from power jack to VDD of the MAX9959
J11	Open*	MAX32625PICO signals (TEMP, ILIMLO, ILIMHI, and HITEMP)
J12	Closed*	MAX32625PICO SPI signals (LOADB, SCLK, DIN, DOUT, SS_MAX9959, SS_ADC, SS_DAC3, and SS_DAC1)
J13	Closed*	MAX9959 SPI signals (LOADB, SCLK, DIN, DOUT, SS_MAX9959)
J14	Closed*	MAX9959 DAC signals
J15	Closed*	MAX5322 DAC signals

*Indicates default jumper state.

Table 4. Test Points

JUMPER	DESCRIPTION
VCC	Power Input: Apply positive voltage from DC power supply in range of +12V to +18V
VEE	Power Input: Apply negative voltage from DC power supply in range of -12V to -15V
VDD	Power Input: Apply positive voltage from DC power supply +5V
VDAC1, VDACC2	LDO output voltage for DACs
VL	LDO output voltage for VL power domain of the MAX9959
OUT_DAC1, OUT_DAC2, OUT_DAC3, OUT_DAC4	DAC output voltage
RA, RB, RC, RD	Test point to measure the voltage across sense resistors connected to the MAX9959 for different current ranges
DUT_NODE	Range A/B/C/D output to which load resistor gets connected
VTHR	Threshold voltage input. Sets the input logic threshold level of all digital inputs.
EXTSEL	External Select Output. Selects the external range.
HITEMP	Temperature Monitor Output. Temp outputs a voltage proportional to die temperature at 10mV/K.
ILIMHI, ILIMLO	Low-Current and High-Current Limit Output. This output is triggered if the load current is above ILIMHI or below ILIMLO.
AMPOUT	Main Amplifier Output. Drives the external buffer when using the external range mode.

*Indicates default jumper state.

Ordering Information

PART	TYPE
MAX9959EVKIT#	EV Kit

#Denotes RoHS complaint

MAX9959 EV Kit Bill of Materials

ITEM	REF_DES	DNI/DNP	QTY	MFG PART #	MANUFACTURER	VALUE	DESCRIPTION	COMMENTS
1	AMPOUT, EXTSEL, HITMP, TP9-TP13, TP17-TP20, VRXP, VTHR	-	14	5012	KEYSTONE	N/A	TEST POINT; PIN DIA=0.125IN; TOTAL LENGTH=0.445IN; BOARD HOLE=0.063IN; WHITE; PHOSPHOR BRONZE WIRE SILVER PLATE FINISH;	
2	C1-C3, C76	-	4	C1210C106K3RAC; GRM32DR71E106K; GCM32ER71E106KA57; CGA6P1X7R1E106K250AC; GCJ32ER71E106KA18	KEMET;MURATA;MURATA; TDK;MURATA	10UF	CAP; SMT (1210); 10UF; 10%; 25V; X7R; CERAMIC	
3	C4, C7, C69, C74, C75	-	5	TMK107B7105KA; 06033C105KAT2A; C1608X7R1E105K080AE	MURATA;TAIYO YUDEN; AVX;TAIYO YUDEN	1UF	CAP; SMT (0603); 1UF; 10%; 25V; X7R; CERAMIC	
4	C5, C8	-	2	C0603C102K1GAC; C1608COG2A102K080AA	KEMET;TDK	1000PF	CAP; SMT (0603); 1000PF; 10%; 100V; C0G; CERAMIC	
5	C6, C9, C63, C65	-	4	C1608X5R1E475K080AC; GRM188R61E475KE11	TDK;MURATA	4.7UF	CAP; SMT (0603); 4.7UF; 10%; 25V; X5R; CERAMIC	
6	C10, C12-C16, C25-C36	-	18	C1608X5R1E106M080AC; CL10A106MABNRNC; GRM188R61E106MA73; ZRB18AR61E106ME01; GRT188R61E106ME13	TDK;SAMSUNG ELECTRONICS; MURATA;MURATA;MURATA	10UF	CAP; SMT (0603); 10UF; 20%; 25V; X5R; CERAMIC	
7	C11	-	1	C0603C473K5RAC; GRM188R71H473KA61; GCM188R71H473KA55; CGA3E2X7R1H473K080AA	KEMET;MURATA;MURATA;TDK	0.047UF	CAP; SMT (0603); 0.047UF; 10%; 50V; X7R; CERAMIC	
8	C17-C24, C37-C48, C64, C66-C68, C70-C73	-	28	06033C104JAT2A	AVX	0.1UF	CAP; SMT (0603); 0.1UF; 5%; 25V; X7R; CERAMIC	
9	C49	-	1	GCM188R71H332KA37	MURATA	3300PF	CAP; SMT (0603); 3300PF; 10%; 50V; X7R; CERAMIC	
10	C50	-	1	C0603C223K5RAC; GRM188R71H223K; C1608X7R1H223K080AA; GCJ188R71H223KA01	KEMET;MURATA;TDK;MURATA	0.022UF	CAP; SMT (0603); 0.022UF; 10%; 50V; X7R; CERAMIC	
11	C51, C54, C60	-	3	CC0603KRX7R9BB331	YAGEO	330PF	CAP; SMT (0603); 330PF; 10%; 50V; X7R; CERAMIC	
12	C52, C56	-	2	C0603X7R500-472KNE; GRM188R71H472KA01	VENKEL LTD.;MURATA	4700PF	CAP; SMT (0603); 4700PF; 10%; 50V; X7R; CERAMIC	
13	C53	-	1	C0603X7R500103JNP; C0603C103J5RAC	VENKEL LTD;KEMET	0.01UF	CAP; SMT (0603); 0.01UF; 5%; 50V; X7R; CERAMIC	
14	C55, C58	-	2	C0603C152K5RAC; C0603X7R500-15	KEMET;VENKEL LTD	1500PF	CAP; SMT (0603); 1500PF; 10%; 50V; X7R; CERAMIC	
15	C57, C59	-	2	06035C101JAT	AVX	100PF	CAP; SMT (0603); 100PF; 5%; 50V; X7R; CERAMIC	
16	C61, C62	-	2	C0603COG500-271JNE; GRM1885C1H271JA01	VENKEL LTD.;MURATA	270PF	CAP; SMT (0603); 270PF; 5%; 50V; C0G; CERAMIC	
17	DS1-DS3	-	3	LTST-C190CKT	LITE-ON ELECTRONICS INC.	LTST-C190CKT	DIODE; LED; STANDARD; RED; SMT (0603); PIV=5.0V; IF=0.04A; -55 DEGC TO +85 DEGC	RED
18	DS4, DS5, DS6, DS8-DS11	-	7	LTST-C193KGKT-5A	LITE-ON ELECTRONICS INC.	LTST-C193KGKT-5A	DIODE; LED; STANDARD; YELLOW-GREEN; SMT (0603); PIV=1.9V; IF=0.005A; -55 DEGC TO +85 DEGC	(DS4,DS5:GREEN)
19	DUT_NODE, TP14	-	2	575-4	KEYSTONE	575-4	RECEPTACLE; JACK; BANANA; 0.203IN [5.2MM] DIA X 0.218IN [5.5MM] L; 0.203D/0.218L; NICKEL PLATED BRASS	
20	FB1-FB6	-	6	MPZ1608S221ATA00	TDK	220	INDUCTOR; SMT (0603); FERRITE-BEAD; 220; TOL=+-25%; 2.2A	
21	GND, TEMP, VCC, VDD, VEE	-	5	9020 BUSS	WEICO WIRE	MAXIMPAD	EVK KIT PARTS; MAXIM PAD; WIRE; NATURAL; SOLID; WEICO WIRE; SOFT DRAWN BUS TYPE-S; 20AWG	
22	HITEMP, ILIMHI, ILIMLO, RA, RB, RC, RD	-	7	5000	KEYSTONE	N/A	TEST POINT; PIN DIA=0.1IN; TOTAL LENGTH=0.3IN; BOARD HOLE=0.04IN; RED; PHOSPHOR BRONZE WIRE SILVER PLATE FINISH;	
23	IMEAS, VMEAS	-	2	5002	KEYSTONE	N/A	TEST POINT; PIN DIA=0.1IN; TOTAL LENGTH=0.3IN; BOARD HOLE=0.04IN; WHITE; PHOSPHOR BRONZE WIRE SILVER;	
24	J1-J3, J6-J9	-	7	PCC02SAAN	SULLINS	PCC02SAAN	CONNECTOR; MALE; THROUGH HOLE; BREAKAWAY; STRAIGHT THROUGH; 2PINS; -65 DEGC TO +125 DEGC	
25	J4	-	1	PBC04DAAN	SULLINS ELECTRONICS CORP.	PBC04DAAN	CONNECTOR; MALE; THROUGH HOLE; BREAKAWAY; STRAIGHT; 8PINS; -65 DEGC TO +125 DEGC	
26	J5	-	1	PEC03SAAN	SULLINS	PEC03SAAN	CONNECTOR; MALE; THROUGH HOLE; BREAKAWAY; STRAIGHT; 3PINS	
27	J10	-	1	ATS-61400D-C1-R0	ADVANCED THERMAL SOLUTIONS INC.	ATS-61400D-C1-R0	MACHINE FABRICATED; HSINK; 39.25X39.25X9.5MM BGA HEAT SINK ASSEMBLY	
28	J11	-	1	PBC04SAAN	SULLINS ELECTRONICS CORP.	PBC04SAAN	CONNECTOR; MALE; THROUGH HOLE; BREAKAWAY; STRAIGHT; 4PINS; -65 DEGC TO +125 DEGC	
29	J12	-	1	PBC08SAAN	SULLINS ELECTRONICS CORP.	PBC08SAAN	CONNECTOR; MALE; THROUGH HOLE; BREAKAWAY; STRAIGHT; 8PINS; -65 DEGC TO +125 DEGC	
30	J13	-	1	PBC05SAAN	SULLINS ELECTRONICS CORP.	PBC05SAAN	CONNECTOR; MALE; THROUGH HOLE; BREAKAWAY; STRAIGHT; 5PINS; -65 DEGC TO +125 DEGC	

MAX9959 EV Kit Bill of Materials (continued)

ITEM	REF_DES	DNI/DNP	QTY	MFG PART #	MANUFACTURER	VALUE	DESCRIPTION	COMMENTS
31	J14, J15	-	2	PEC07SAAN	SULLINS ELECTRONICS CORP.	PEC07SAAN	CONNECTOR; MALE; THROUGH HOLE; BREAKAWAY; STRAIGHT; 7PINS; -65 DEGC TO +125 DEGC	
32	MH1-MH8	-	8	9032	KEystone	9032	MACHINE FABRICATED; ROUND-THRU HOLE SPACER; NO THREAD; M3.5; 5/8IN; NYLON	
33	R4, R7	-	2	ERJ-3GEYJ394	PANASONIC	390K	RES; SMT (0603); 390K; 5%; +/-200PPM/DEGC; 0.1000W	
34	R5, R8	-	2	PNM0603E5002BS	VISHAY DALE	50K	RES; SMT (0603); 50K; 0.10%; +/-25PPM/DEGC; 0.1500W	
35	R6, R9, R36, R40	-	4	CRCW060310K0FK; ERJ-3EKF1002; AC0603FR-0710KL; RMC0603FT10K0	VISHAY DALE;PANASONIC; YAGEO	10K	RES; SMT (0603); 10K; 1%; +/-100PPM/DEGC; 0.1000W	
36	R10-R13, R15, R17	-	6	CRCW06030000Z0	VISHAY DALE	0	RES; SMT (0603); 0; JUMPER; JUMPER; 0.1000W	
37	R14, R16, R35, R39, R42, R44, R47, R48, R50	-	9	CRCW06031K00FK; ERJ-3EKF1001; CR0603AFX-1001ELF	VISHAY; PANASONIC;BOURNS	1K	RES; SMT (0603); 1K; 1%; +/-100PPM/DEGC; 0.1000W	
38	R18-R25	-	8	CRCW060322K0FK	VISHAY DALE	22K	RES; SMT (0603); 22K; 1%; +/-100PPM/DEGC; 0.1000W	
39	R31, R33	-	2	CRCW121010R0FKEAHP; CRGP1210F10R	VISHAY DRALORIC; TE CONNECTIVITY	10	RES; SMT (1210); 10; 1%; +/-100PPM/DEGC; 0.7500W	
40	R32, R34	-	2	ERJ-8BQF3R3	PANASONIC	3.3	RES; SMT (1206); 3.3; 1%; +/-200PPM/DEGC; 0.5000W	
41	R37, R38	-	2	CRCW1210100RFK	VISHAY DALE	100	RES; SMT (1210); 100; 1%; +/-100PPM/DEGC; 0.5000W	
42	R41, R43, R45, R46, R49	-	5	TNPW060310K0BE; RN731JTTD1002B	VISHAY DALE;KOA SPEER ELECTRONICS	10K	RES; SMT (0603); 10K; 0.10%; +/-25PPM/DEGC; 0.1000W	
43	R51	-	1	RCW06033K30FK; RC0603FR-073K3L; RK73H1J3301F	VISHAY;YAGEO;VISHAY	3.3K	RES; SMT (0603); 3.3K; 1%; +/-100PPM/DEGC; 0.1000W	
44	R53, R55	-	2	ERJ-3GEYJ102	PANASONIC	1K	RES; SMT (0603); 1K; 5%; +/-200PPM/DEGC; 0.1000W	
45	R54, R68	-	2	CRCW06032K70FK; ERJ-3EKF2701	VISHAY DALE;PANASONIC	2.7K	RES; SMT (0603); 2.7K; 1%; +/-100PPM/DEGC; 0.1000W	
46	R56, R57, R60, R61	-	4	ERJ-3EKF3481	PANASONIC	3.48K	RES; SMT (0603); 3.48K; 1%; +/-100PPM/DEGC; 0.1000W	
47	R58, R59, R62, R63	-	4	RNCP0603FTD2K00	STACKPOLE ELECTRONICS INC.	2K	RES; SMT (0603); 2K; 1%; +/-100PPM/DEGC; 0.1250W	
48	SU1-SU21	-	21	NPC02SXON-RC	SULLINS ELECTRONICS CORP.	NPC02SXON-RC	CONNECTOR; FEMALE; MINI SHUNT; 0.100IN CC; OPEN TOP; JUMPER; STRAIGHT; 2PINS	
49	TP1-TP4	-	4	3267	POMONA ELECTRONICS	3267	CONNECTOR; MALE; PANELMOUNT; STANDARD UNINSULATED BANANA JACK; STRAIGHT; 1PIN	
50	TP5, TP8, TP22, VDAC, VL	-	5	5005	KEystone	N/A	TEST POINT; PIN DIA=0.125IN; TOTAL LENGTH=0.35IN; BOARD HOLE=0.063IN; RED; PHOSPHOR BRONZE WIRE SILVER PLATE FINISH;	
51	TP6, TP7, TP21	-	3	5006	KEystone	N/A	TEST POINT; PIN DIA=0.125IN; TOTAL LENGTH=0.35IN; BOARD HOLE=0.063IN; BLACK; PHOSPHOR BRONZE WIRE SILVER PLATE FINISH;	
52	U1, U2	-	2	MAX16910CATA8+	MAXIM	MAX16910CATA8+	IC; VREG; 0.2A; ULTRA-LOW QUIESCENT CURRENT; LINEAR REGULATOR; TDFN8-EP 3X3	
53	U3	-	1	MAX38903AATB+	MAXIM	MAX38903AATB+	EVKIT PART-IC; PKG. CODE: T1033+1C; PKG. OUTLINE NO.: 21-0137; PACKAGE LAND PATTERN: 90-0003	
54	U4, U5	-	2	MAX6126AASA50+	MAXIM	MAX6126AASA50+	IC; VREF; ULTRA-HIGH PRECISION; ULTRA-LOW NOISE; SERIES VOLTAGE REFERENCE; NSOIC8 150MIL	
55	U6, U7	-	2	MAX6126B21+	MAXIM	MAX6126B21+	IC; VREF; ULTRA-HIGH PRECISION; ULTRA-LOW NOISE; SERIES VOLTAGE REFERENCE; UMAX8	
56	U8-U11	-	4	MAX5322EAI+	MAXIM	MAX5322EAI+	IC; DAC; +/-10V, DUAL, 12-BIT, SERIAL, VOLTAGE-OUTPUT DAC; SSOP28	
57	U12	-	1	MAX9959DCCQ+	MAXIM	MAX9959DCCQ+	IC; PWRMOD; 25V SPAN; 800 MILLIAMPERE DEVICE POWER SUPPLY (DPS); TQFP100-IDP	
58	U13	-	1	MAX32625PICO	MAXIM	MAX32625PICO	MODULE; BOARD; MAX32625PICO BOARD DESIGN FOR MAX32625 ARM CORTEX-M4F; BOARD; LAMINATED PLASTIC WITH COPPER CLAD;	
59	U14	-	1	MAX44245AUD+	MAXIM	MAX44245AUD+	IC; OPAMP; 36V; PRECISION; LOW-POWER; 90MICRO-AMPERE; QUAD OP AMPS; TSSOP14	
60	U15	-	1	MAX14759ETA+	MAXIM	MAX14759ETA+	IC; ASW; ABOVE- AND BELOW-THE-RAILS LOW ON-RESISTANCE ANALOG SWITCH; TDFN8-EP	
61	U16	-	1	MAX1033BEUP+	MAXIM	MAX1033BEUP+	IC; ADC; 4-CHANNEL; +/-3 X VREF MULTIRANGE INPUTS; SERIAL 14-BIT ANALOG-TO-DIGITAL CONVERTER; TSSOP20	
62	PCB	-	1	MAX9959	MAXIM	PCB	PCB:MAX9959	
63	J10	DNI	1	MF40200V3-1000U-A99	SUNON	N/A	FAN;PANELMOUNT 40MMX40MMX20MM; 5V	
64	MISC1	DNI	1	3025010-03	QUALTEK ELECTRONICS CORP	3025010-03	CONNECTOR; MALE; USB-A_MINI-B; USB 4P(A)/M - USB MINI 5P(B)/M; STRAIGHT; 36IN	
65	D1-D3	DNP	0	1N5250B	FAIRCHILD SEMICONDUCTOR	20V	DIODE, ZENER, DO-35, Pd=0.5W, Vz=20V@Iz=6.2mA	
66	R1-R3, R26-R30	DNP	0	N/A	N/A	OPEN	PACKAGE OUTLINE 0603 RESISTOR	
TOTAL			252					

MAX9959 EV Kit Schematic

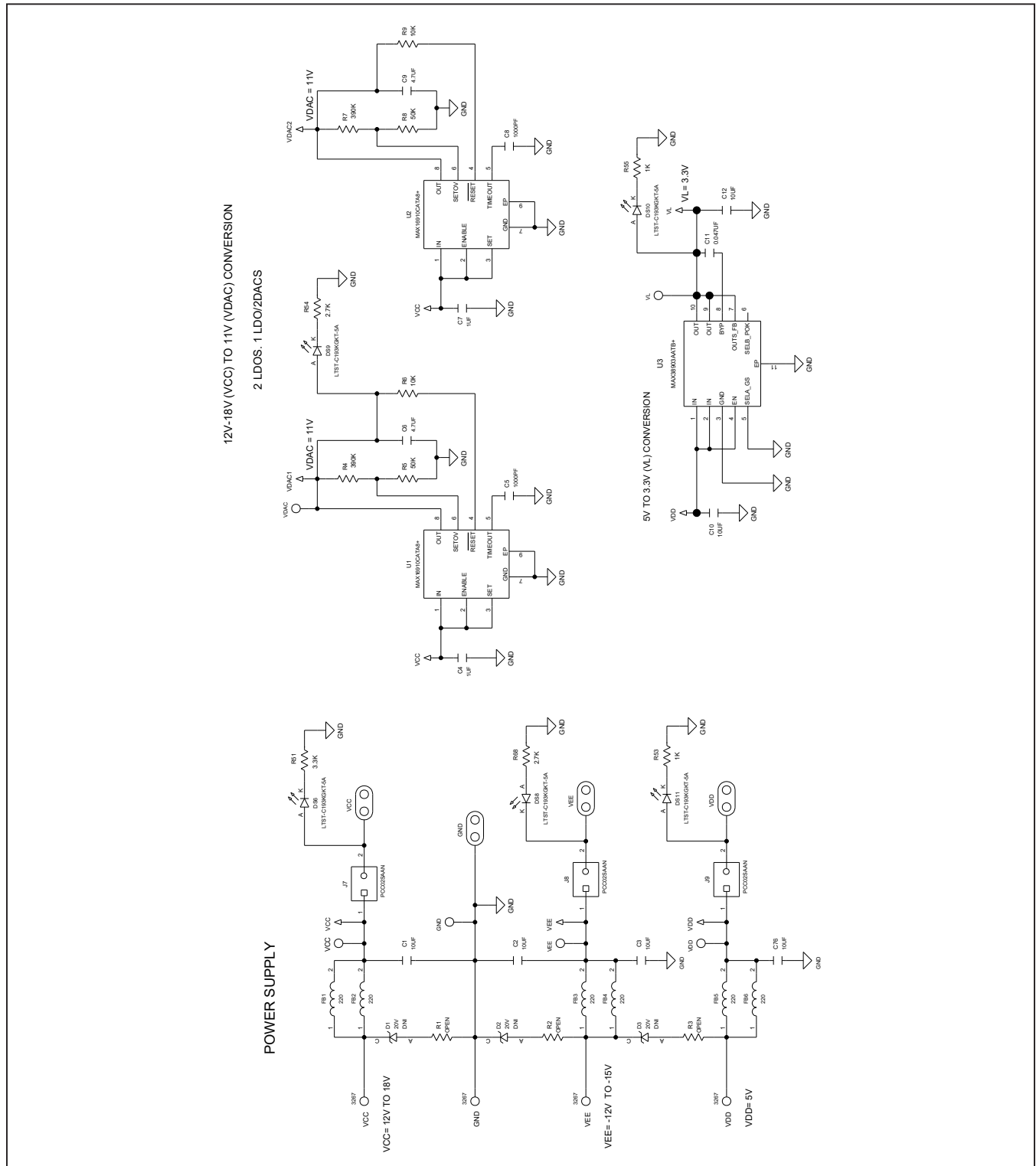

MAX9959 EV Kit Schematic (continued)

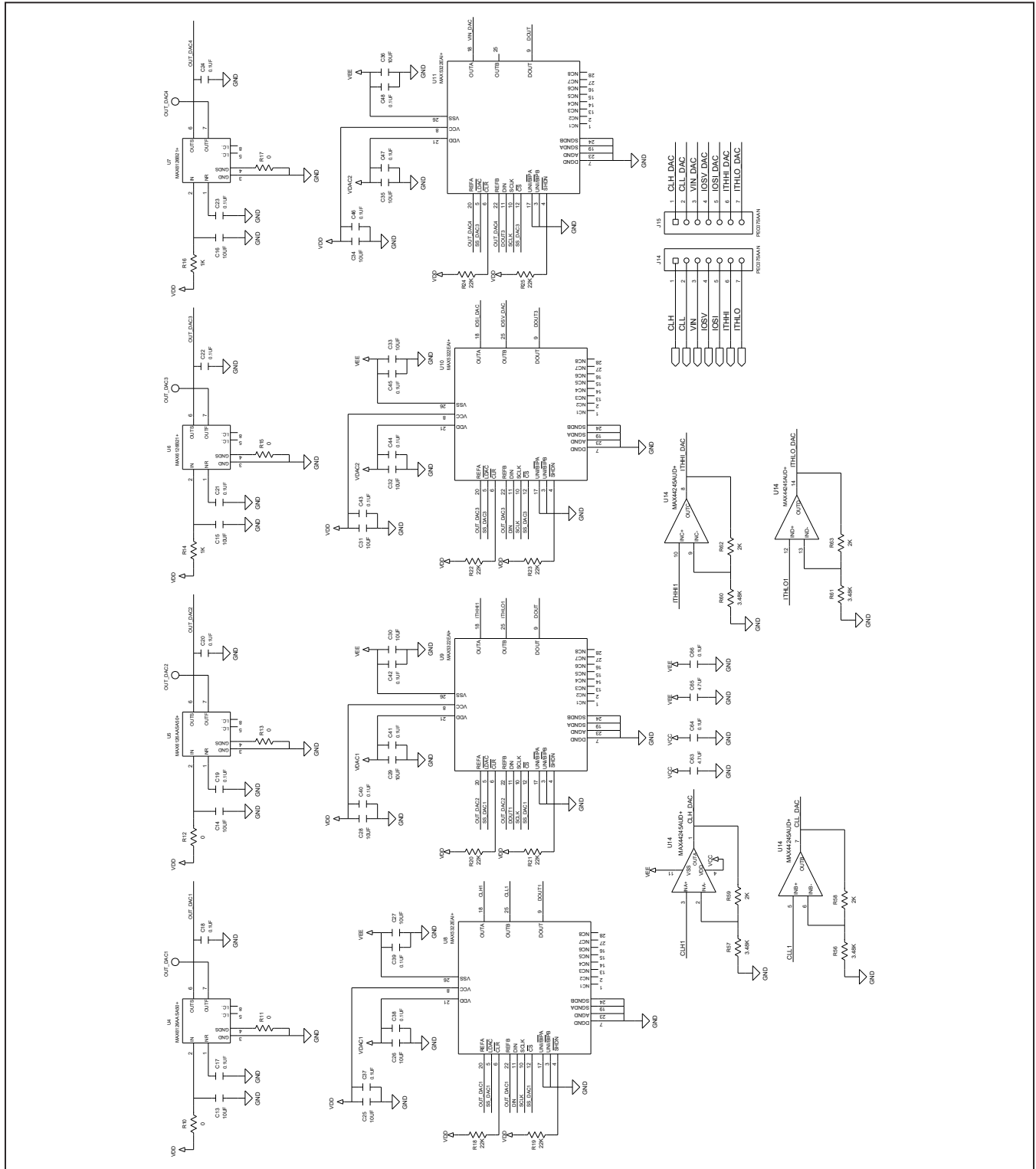

MAX9959 EV Kit Schematic (continued)

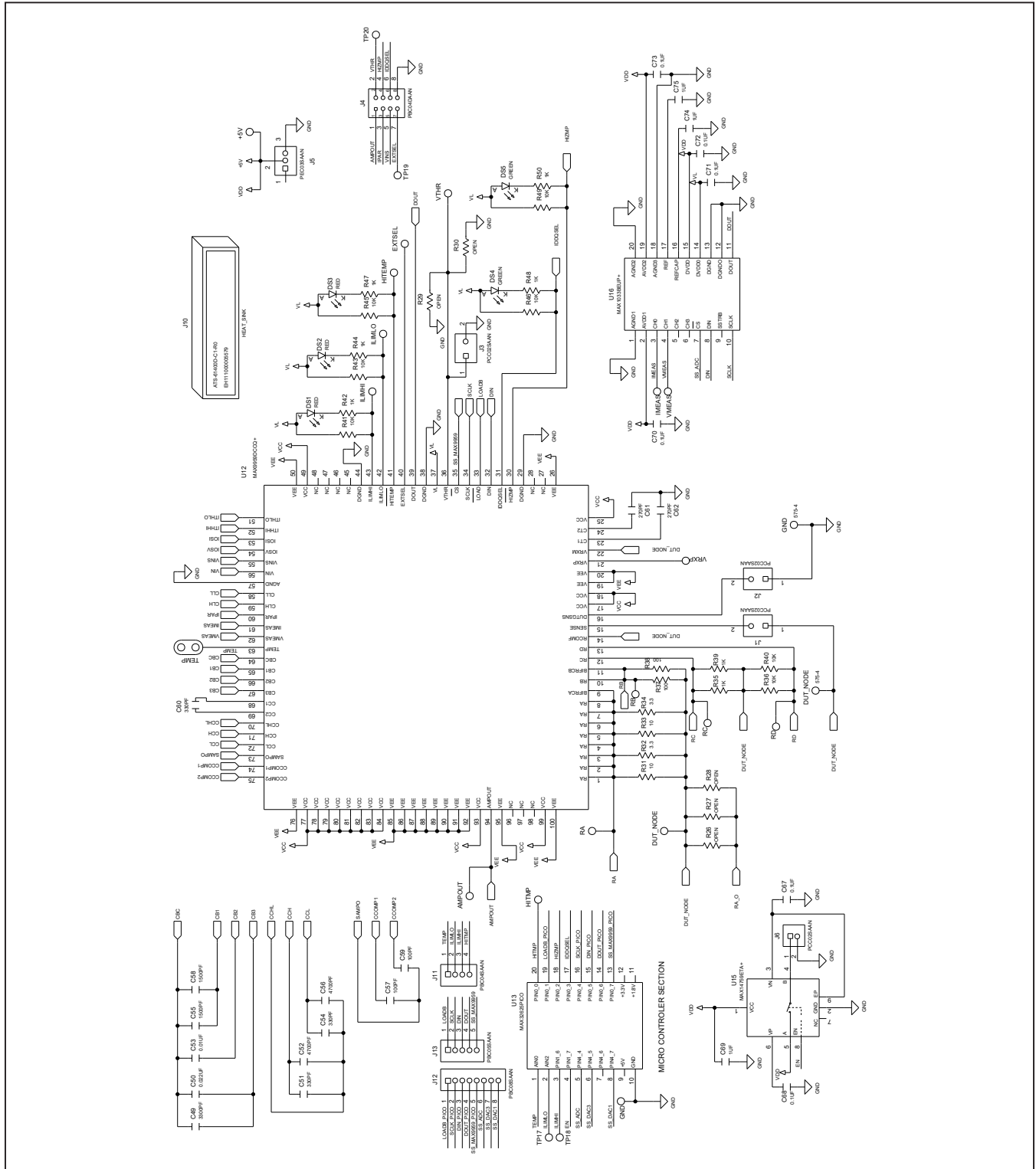

MAX9959 EV Kit PCB Layout

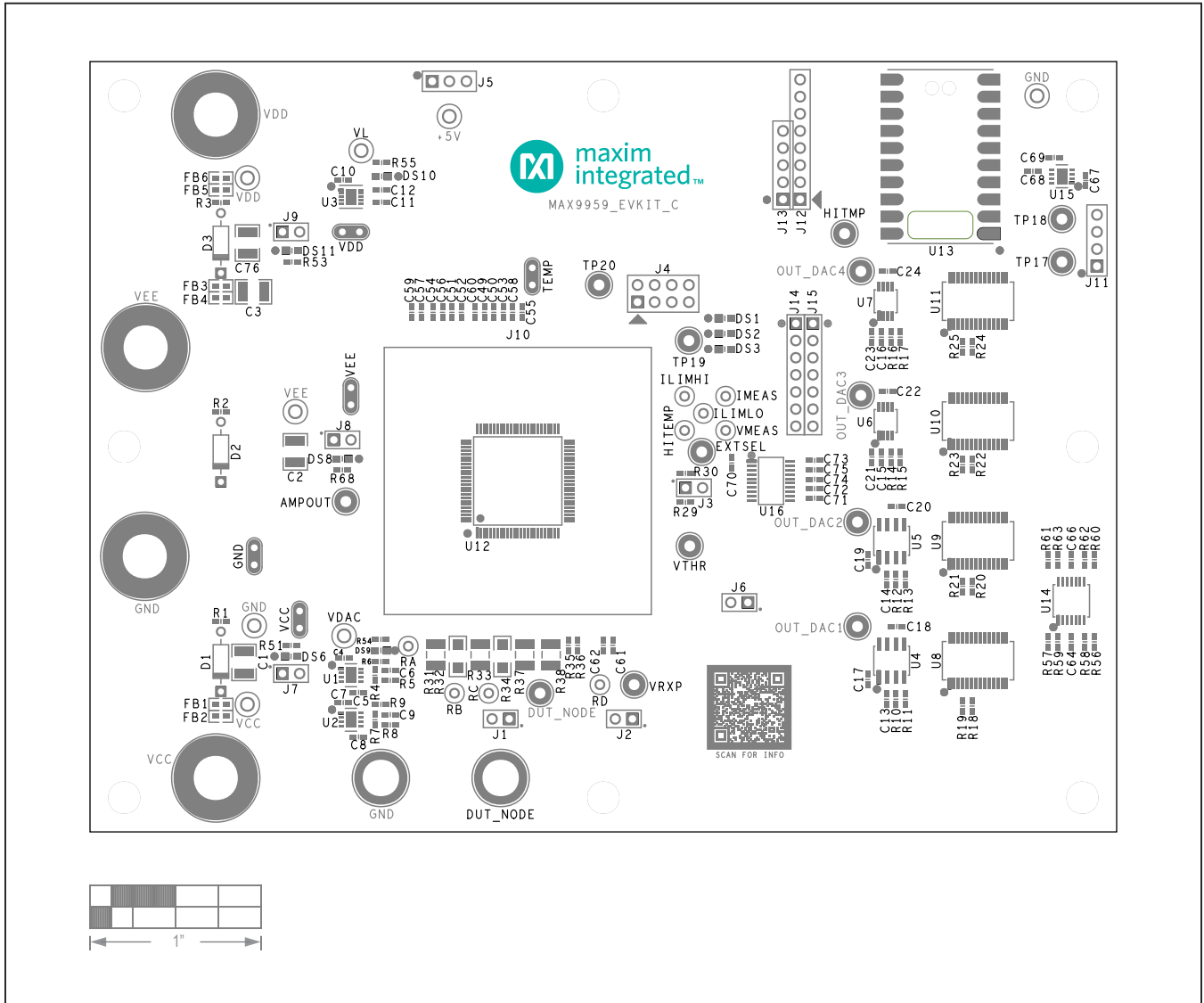

MAX9959 EV Kit—Silk Top

MAX9959 EV Kit PCB Layout (continued)

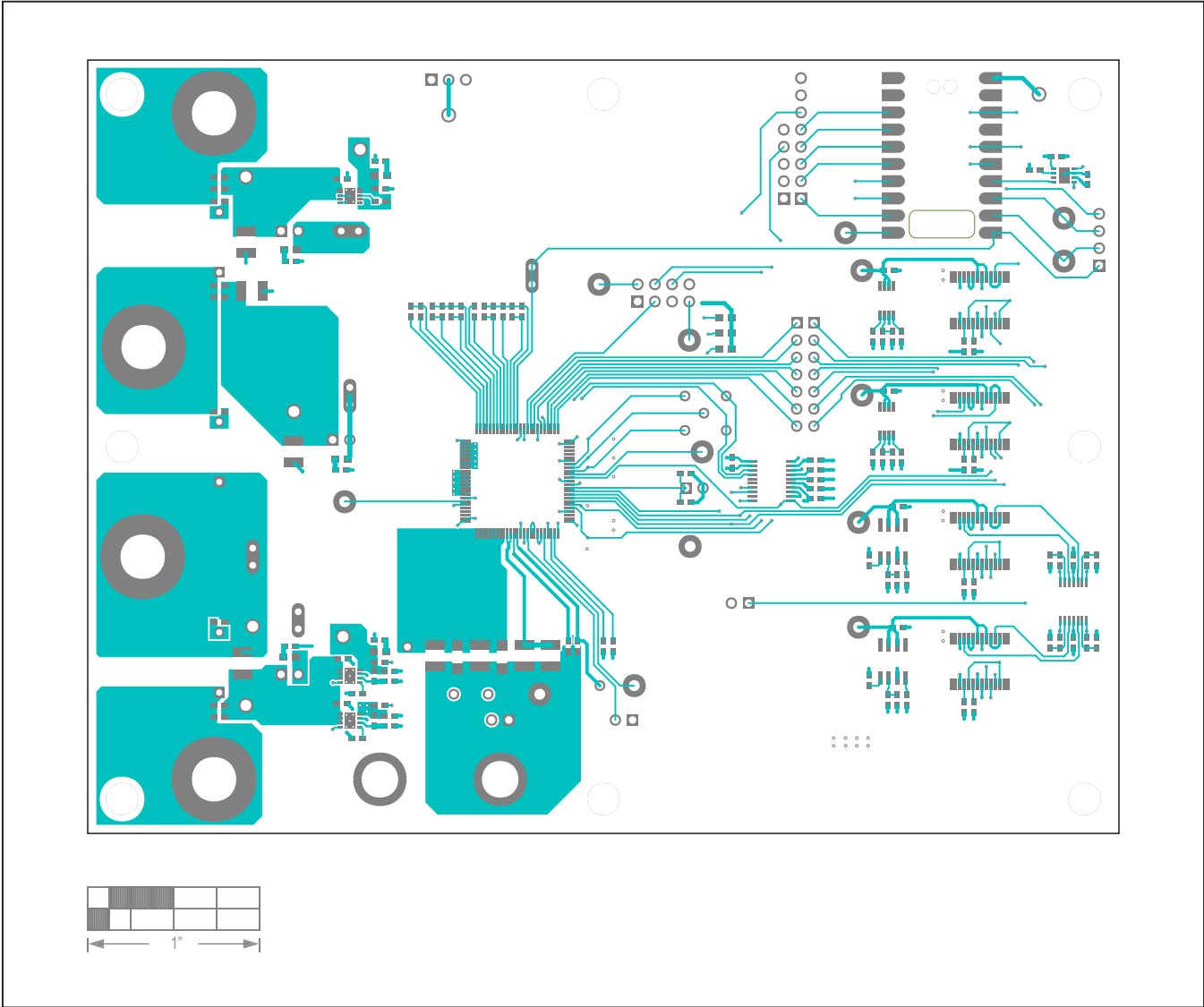

MAX9959 EV Kit—Top

MAX9959 EV Kit PCB Layout (continued)

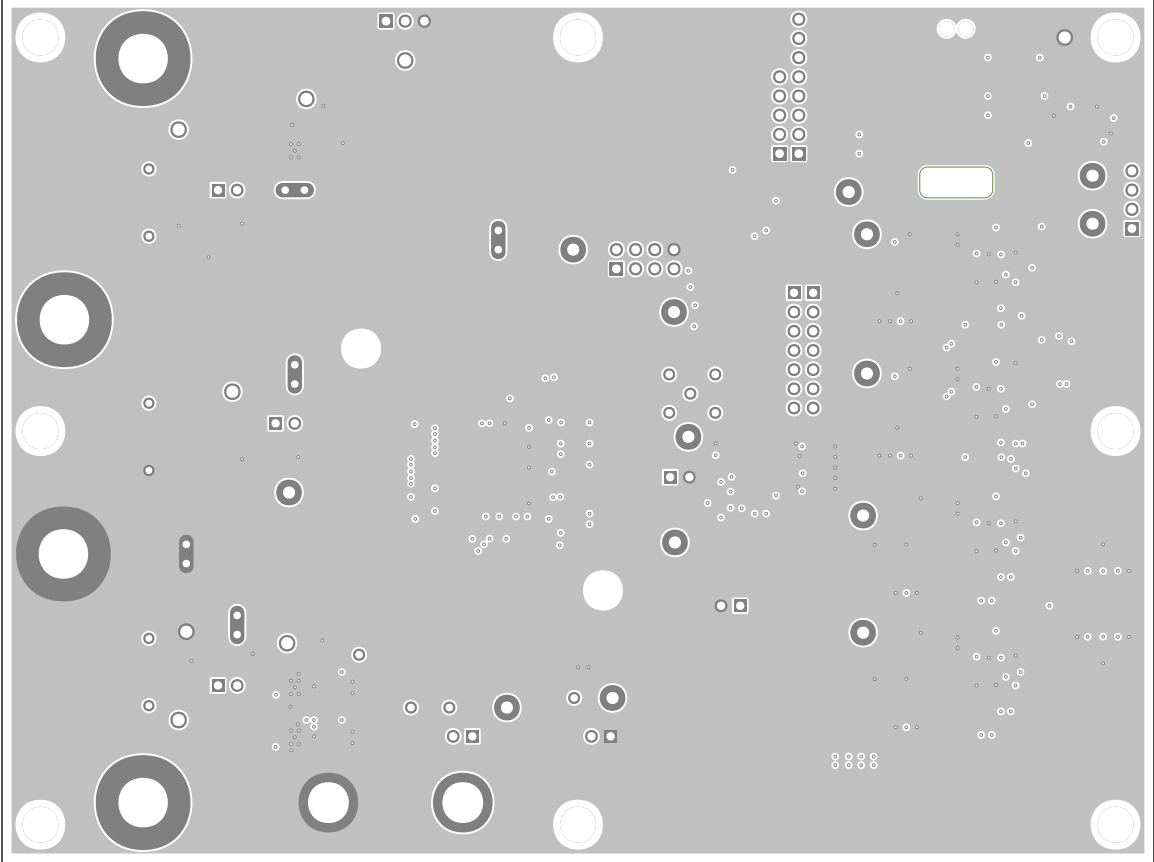

MAX9959 EV Kit—Internal2

MAX9959 EV Kit PCB Layout (continued)

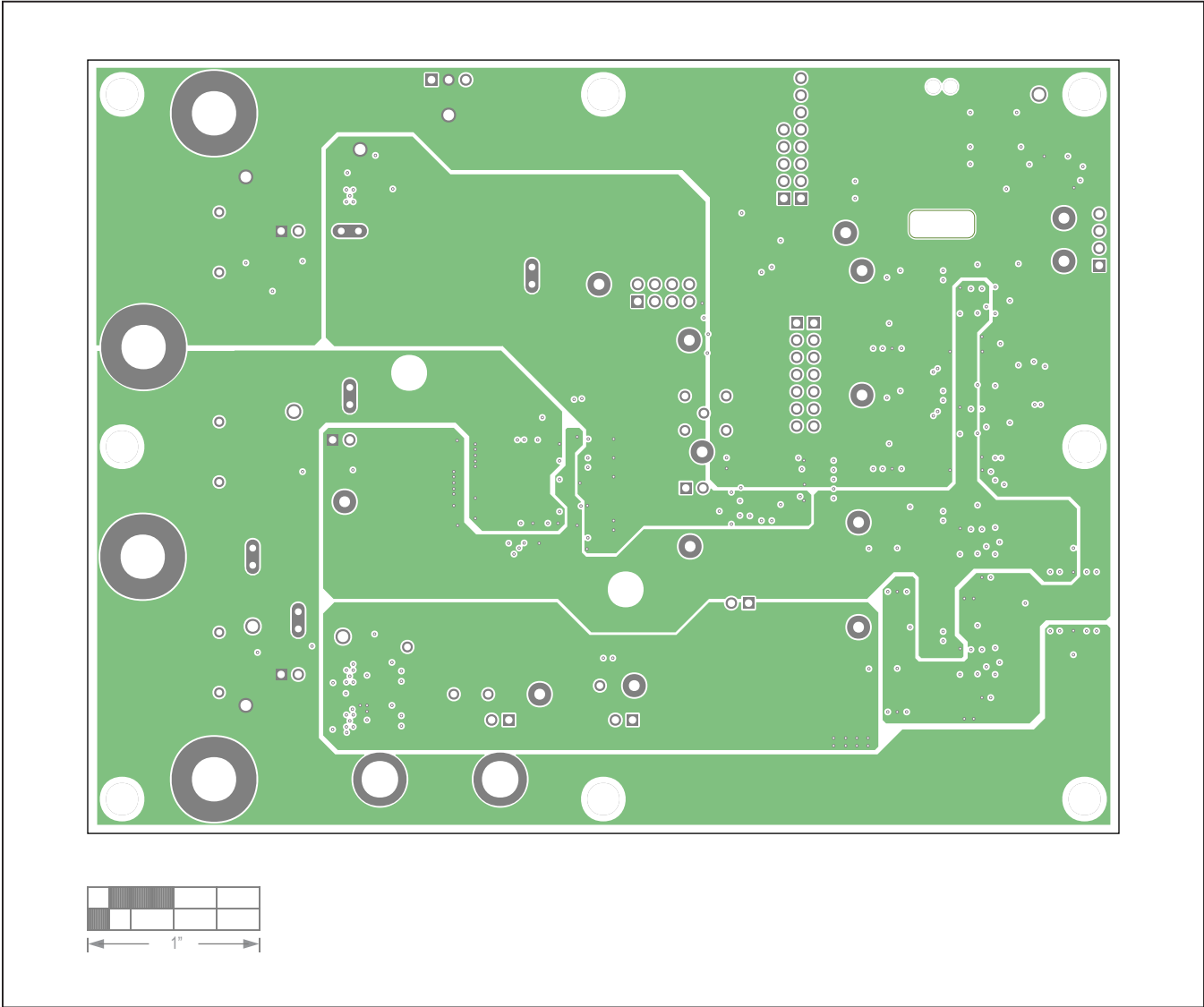

MAX9959 EV Kit—Internal3

MAX9959 EV Kit PCB Layout (continued)

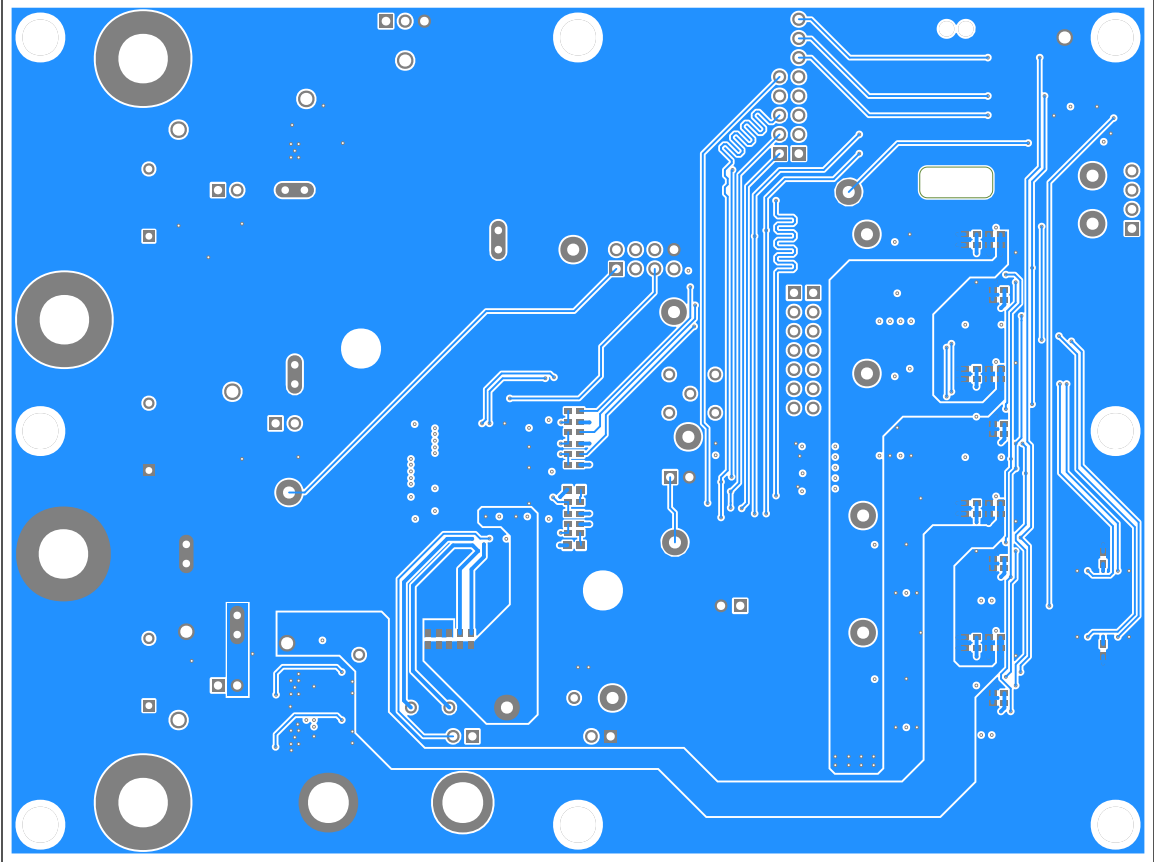

MAX9959 EV Kit—Bottom

MAX9959 EV Kit PCB Layout (continued)

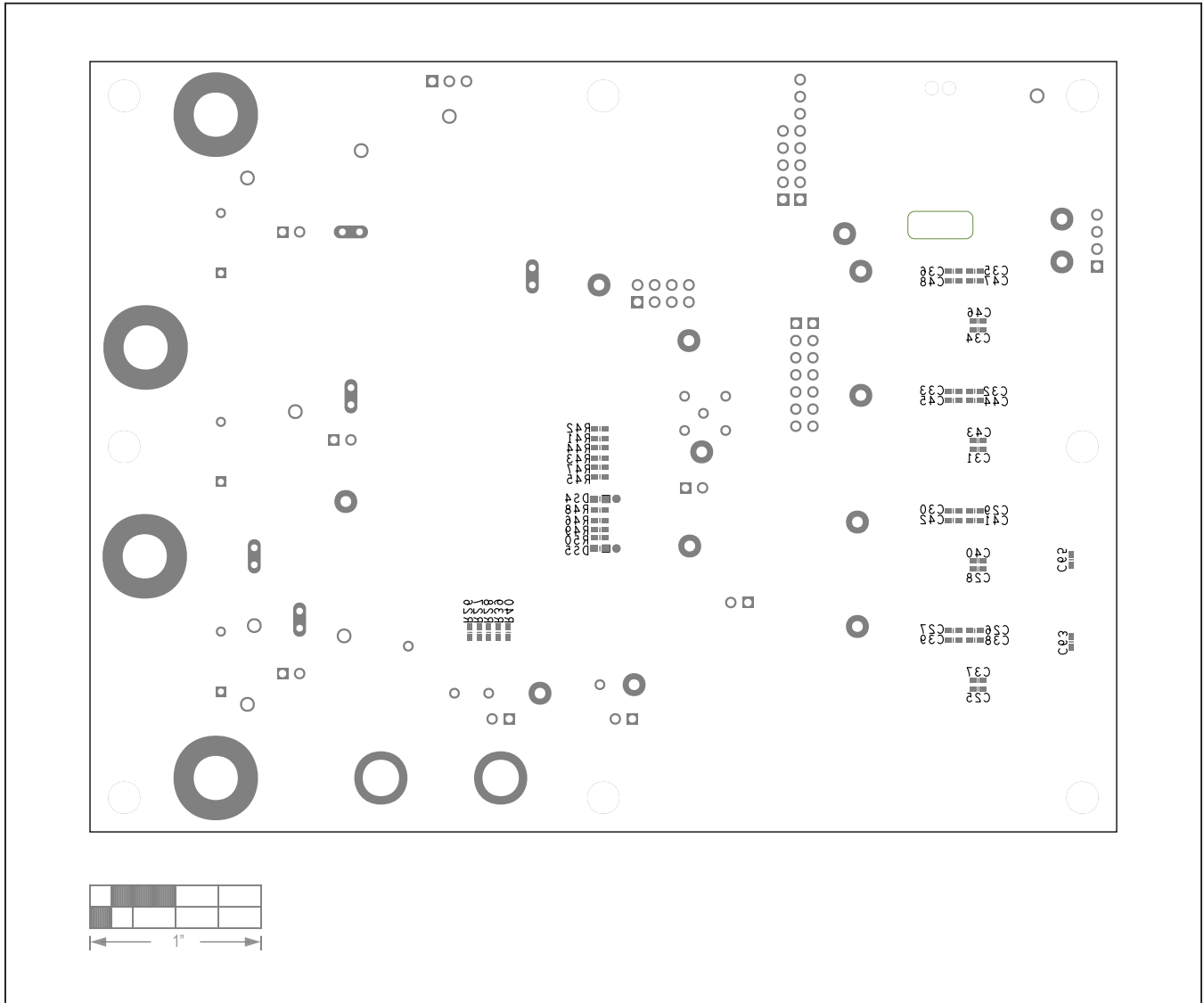

MAX9959 EV Kit—Silk Bottom