

Evaluates: MAXM17623/MAXM17624 Modules in Application

MAXM17623/MAXM17624 Evaluation Kit

General Description

The MAXM17623/MAXM17624 evaluation kits (EV kits) provide a proven design to evaluate the performance of the MAXM17623/MAXM17624 modules. Each of these modules are configured to demonstrate optimum performance and component sizes in the EV kits.

The MAXM17623 module delivers up to 1A at a switching frequency of 2MHz. The module is configured for a 1.5V output over a 2.9V to 5.5V input range.

The MAXM17624 module delivers up to 1A at a switching frequency of 4MHz. The module is configured for a 3.3V output over a 3.6V to 5.5V input range.

The EV kits feature provisions for selecting Mode of operation (pulse-width modulation and pulse-frequency modulation) and Enable input. The MAXM17623/MAXM17624 module data sheet provides a complete description of the parts that should be read in conjunction with this EV kit data sheet prior to operating the EV kits.

Ordering Information appears at end of data sheet.

Features

- Operates up to 5.5V Input Supply
- MAXM17623 Offers High 90.3% Efficiency ($V_{IN} = 5V$, $V_{OUT} = 1.5V$, $I_{OUT} = 400mA$)
- MAXM17624 Offers High 95.2% Efficiency ($V_{IN} = 5V$, $V_{OUT} = 3.3V$, $I_{OUT} = 400mA$)
- Up to 1A Load Current
- 2MHz Fixed Switching Frequency for the MAXM17623
- 4MHz Fixed Switching Frequency for the MAXM17624
- Selectable Pulse-Width Modulation (PWM) and Pulse-Frequency Modulation (PFM) Modes of Operation
- Internal 1ms Soft-Start Time
- Power-Good (PGOOD) Output with Pullup Resistor to Respective Input Voltages
- Low-Profile, Surface-Mount Components
- Proven PCB Layout
- Fully Assembled and Tested
- Complies with CISPR32 (EN55032) Class B Conducted and Radiated Emissions

MAXM17623/MAXM17624 EV Kit Top View

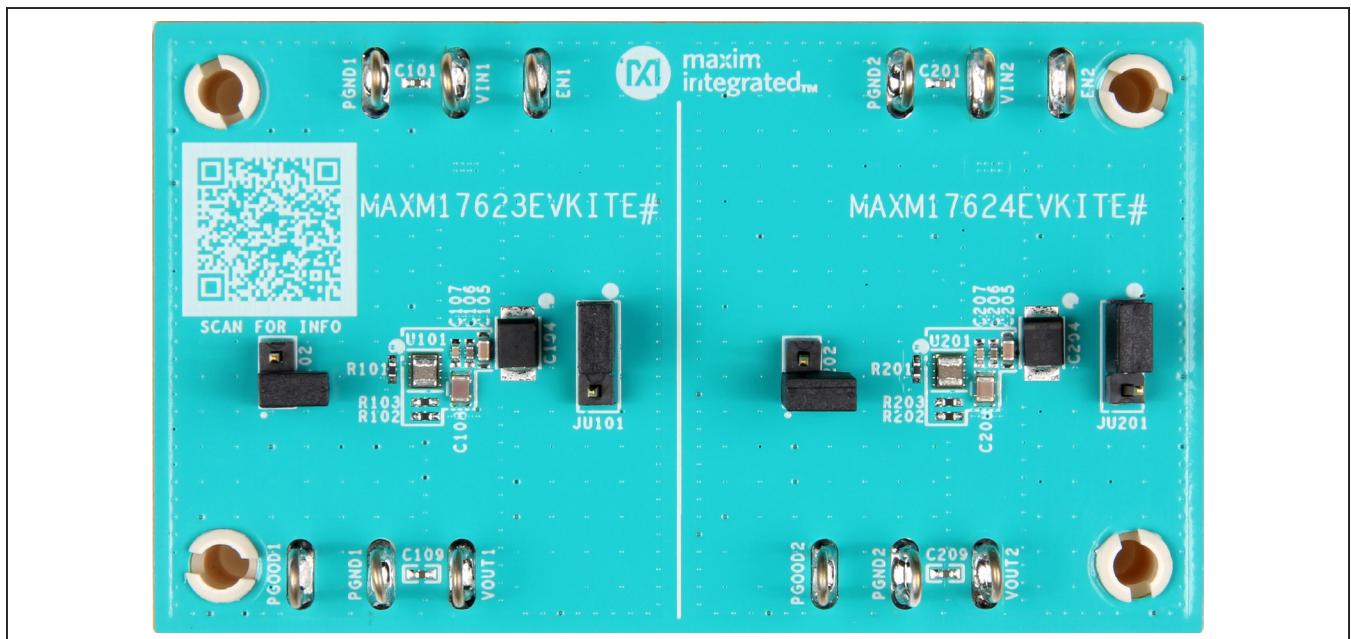

319-100905; Rev 0; 4/22

MAXM17623/MAXM17624 Evaluation Kit

Evaluates: MAXM17623/MAXM17624
Modules in Application

Quick Start

Configuration Diagram

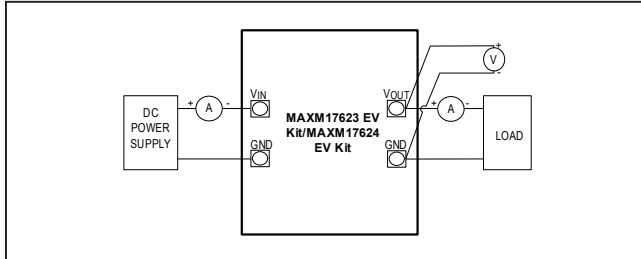

Required Equipment

- One 2.9V to 5.5V DC, 1A power supply
- Load resistors capable of sinking up to 1A at 1.5V and 3.3V (1.5Ω for the MAXM17623 and 3.3Ω for the MAXM17624)
- Digital multimeter (DMM)

Equipment Setup and Procedure

The EV kit is fully assembled and tested. Follow the steps below to verify and test individual modules operation:

Caution: Do not turn on power supply until all connections are completed.

- 1) Disable the power supply and set the input power supply at a valid input voltage.
- 2) Connect the positive terminal and negative terminal of the power supply to the VIN pad and its adjacent PGND pad of the module under evaluation.
- 3) Connect a 1A (max) resistive load across the VOUT pad and its nearest PGND pad of the corresponding module.
- 4) Verify that shunts are installed in default position on jumpers, JU101 for the MAXM17623 and JU201 for the MAXM17624 (see [Table 1](#) for details).
- 5) Select the shunt position on jumpers, JU102 for the MAXM17623 and JU202 for the MAXM17624 according to the required mode of operation (see [Table 2](#) for details).
- 6) Connect the DMM in voltage measurement mode across the V_{OUT} and its respective PGND pad.
- 7) Turn on the input power supply.
- 8) Verify that the DMM displays expected terminal voltage with respect to PGND.

Detailed Description

The MAXM17623/MAXM17624 EV kits are designed to demonstrate the salient features of the MAXM17623/MAXM17624 power modules. The EV kits consist of typical application circuits of two different modules. Each of these circuits are electrically isolated from each other and hosted on the same printed circuit board (PCB). Each of these circuits can be evaluated for its performance under different operating conditions by powering them from their respective input pins.

MODE Selection

The MAXM17623/MAXM17624 supports PWM and PFM modes of operation. In the EV kits, leave the jumpers JU102 for the MAXM17623 and JU202 for the MAXM17624 open for operating the modules in PFM mode at light load. Install shunts to configure the modules in PWM mode. See [Table 2](#) for jumper settings. Refer to MODE Selection section of the MAXM17623/MAXM17624 data sheet for more details.

Adjusting Output Voltage

- The MAXM17623 supports a 0.8V to 1.5V adjustable output voltage, and the MAXM17623 EV kit output voltage is preset to 1.5V.
- The MAXM17624 supports a 1.5V to 3.3V adjustable output voltage, and the MAXM17624 EV kit output voltage is preset to 3.3V.
- For the MAXM17623, the output voltage is programmed using the resistor-divider R102 and R103, and for the MAXM17624, the output voltage is programmed using the resistor-divider R202 and R203. Refer to the Adjusting Output Voltage section in the MAXM17623/MAXM17624 data sheet for more details.

Output Capacitor Selection

The X7R ceramic capacitors are preferred due to their stability over temperature in industrial applications. For the MAXM17623, the required output capacitor (C108) is 22μF/6.3V, and for the MAXM17624, the required output capacitor (C208) is 10μF/16V. Refer to Output Capacitor Selection section in the MAXM17623/MAXM17624 data sheet for more details.

MAXM17623/MAXM17624 Evaluation Kit

Evaluates: MAXM17623/MAXM17624 Modules in Application

Input Capacitor Selection

The input capacitors C105 for the MAXM17623 and C205 for the MAXM17624 serve to reduce the current peaks drawn from the input power supply and reduce switching frequency ripple at the input. Refer to the Input Capacitor Selection section in the MAXM17623/MAXM17624 data sheet to choose input capacitance. A 2.2 μ F/10V input capacitor is chosen for both the MAXM17623 and MAXM17624.

Electromagnetic Interference

Compliance to conducted emissions (CE) standards requires an electromagnetic interference (EMI) filter at the input of a switching power module. The EMI filter attenuates high-frequency currents drawn by the switching power module and limits the noise injected back into the input power source. Use of EMI filter components as shown in the EV kit schematic results in lower conducted emissions below CISPR32 Class B limits. Manufacturer part numbers of the EMI filter components are listed as optional BOM. The EV kits' PCB layout are also designed to limit radi-

ated emissions from switching nodes of the power module, resulting in radiated emissions below CISPR32 Class B limits. Further, capacitors placed near the input of the board help in attenuating high-frequency noise.

Hot Plug-In and Long Input Cables

The MAXM17623/MAXM17624 EV kit PCB provides optional tantalum capacitors (C104 for the MAXM17623 and C204 for the MAXM17624, 47 μ F/8V) to dampen input voltage peaks and oscillations that can arise during the hot plug-in and/or due to long input cables. These capacitors limit the peak voltage at the input of the device when the EV kits are powered directly from a precharged capacitive source or an industrial backplane PCB. Long input cables between the input power source and the EV kits circuit can cause input-voltage oscillations due to the inductance of the cables. The equivalent series resistance (ESR) of the tantalum capacitor helps damp out the oscillations caused by long input cables. Further, capacitors (C101 for the MAXM17623 and C201 for the MAXM17624, 0.1 μ F/16V) placed near the input of the board helps in attenuating high-frequency noise.

Table 1. EN Jumper Description (JU101, JU201)

SHUNT POSITION	EN/UVLO PIN	OUTPUT
1-2*	Connected to VIN	Enabled
2-3	Connected to GND	Disabled

*Default position.

Table 2. MODE Jumper Description (JU102, JU202)

SHUNT POSITION	MODE/SYNC PIN	MODE
1-2	Connected to GND	Operates in PWM Mode in all load conditions
Not installed*	Unconnected	Operates in PFM Mode in light load conditions

*Default position.

Component Suppliers

SUPPLIER	WEBSITE
Murata Americas	www.murata.com
TDK Corp.	www.tdk.com
Kemet	www.kemet.com
Vishay	www.vishay.com
Panasonic Corp.	www.panasonic.com

Ordering Information

PART	TYPE
MAXM17623EVKITE#	EVKit
MAXM17624EVKITE#	EVkit

#Denotes RoHS compliance.

MAXM17623/MAXM17624 Evaluation Kit

Evaluates: MAXM17623/MAXM17624 Modules in Application

MAXM17623/MAXM17624 EV Kits Performance Report

($V_{IN} = V_{EN} = 5V$, $V_{SGND} = V_{PGND} = 0V$, $L_X = \text{Open}$, $T_A = -40^\circ\text{C}$ to $+125^\circ\text{C}$, unless otherwise noted. Typical values are at $T_A = +25^\circ\text{C}$. All voltages are referenced to $SGND$, unless otherwise noted.)

MAXM17623 EFFICIENCY vs. LOAD CURRENT
 $V_{OUT} = 1.5V$, PWM & PFM MODE

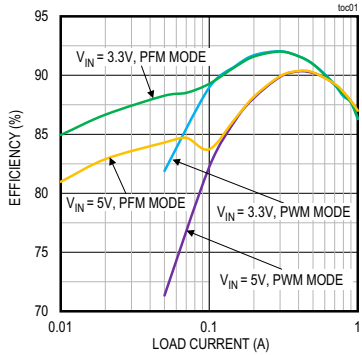

MAXM17623 OUTPUT VOLTAGE vs. LOAD CURRENT
 $V_{OUT} = 1.5V$, PWM & PFM MODE

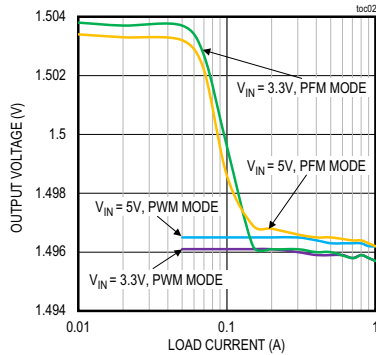

MAXM17624 EFFICIENCY vs. LOAD CURRENT
 $V_{IN} = 5V$, $V_{OUT} = 3.3V$, PWM & PFM MODE

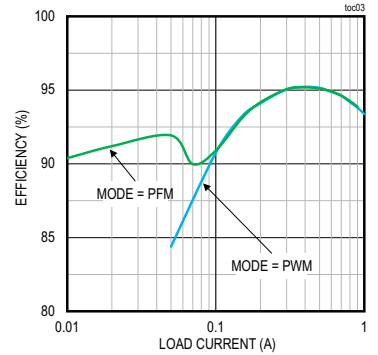

MAXM17624 OUTPUT VOLTAGE vs. LOAD CURRENT
 $V_{IN} = 5V$, $V_{OUT} = 3.3V$, PWM & PFM MODE

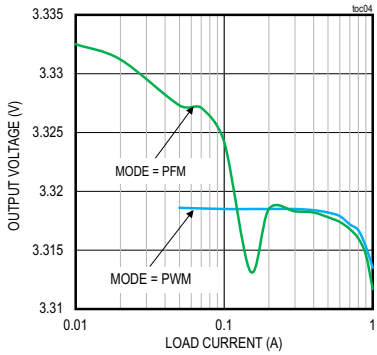

MAXM17623 BODE PLOT
 $V_{IN} = 3.3V$, $V_{OUT} = 1.5V$, FULL LOAD, PWM MODE

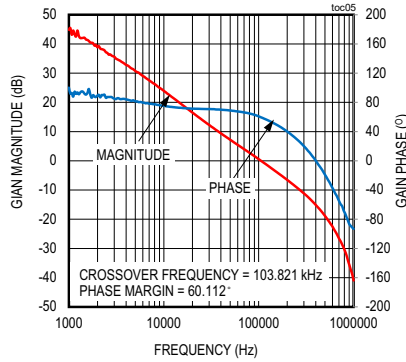

MAXM17624 BODE PLOT
 $V_{IN} = 5V$, $V_{OUT} = 3.3V$, FULL LOAD, PWM MODE

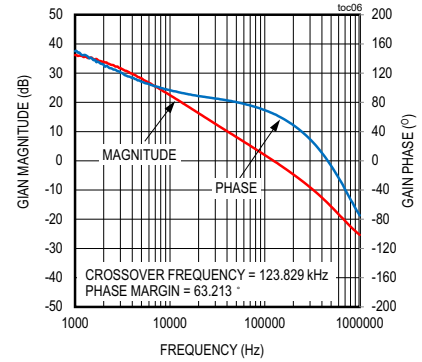

MAXM17623 LOAD TRANSIENT RESPONSE
 $V_{IN} = 3.3V$, $V_{OUT} = 1.5V$, MODE = PWM
(LOAD CURRENT STEPPED FROM 0.5 TO 1A)

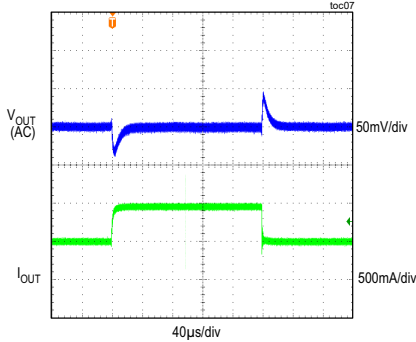

MAXM17623 LOAD TRANSIENT RESPONSE
 $V_{IN} = 3.3V$, $V_{OUT} = 1.5V$, MODE = PFM
(LOAD CURRENT STEPPED FROM 0A TO 500mA)

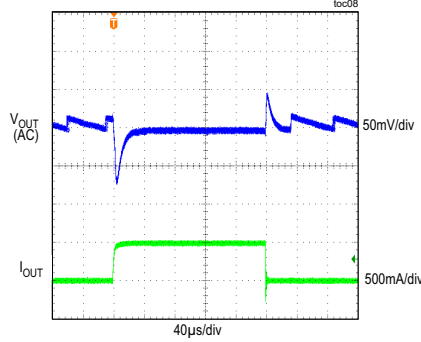

MAXM17624 LOAD TRANSIENT RESPONSE
 $V_{IN} = 5V$, $V_{OUT} = 3.3V$, MODE = PWM
(LOAD CURRENT STEPPED FROM 0.5 TO 1A)

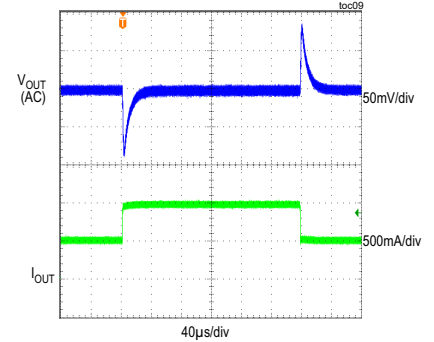

MAXM17623/MAXM17624 EV Kits Performance Report (continued)

($V_{IN} = V_{EN} = 5V$, $V_{SGND} = V_{PGND} = 0V$, $LX = \text{Open}$, $T_A = -40^\circ\text{C}$ to $+125^\circ\text{C}$, unless otherwise noted. Typical values are at $T_A = +25^\circ\text{C}$. All voltages are referenced to SGND, unless otherwise noted.)

MAXM17624 LOAD TRANSIENT RESPONSE
 $V_{IN} = 5V$, $V_{OUT} = 3.3V$, MODE = PFM
(LOAD CURRENT STEPPED FROM 0A TO 500mA)

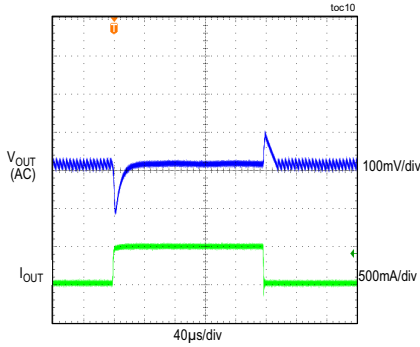

MAXM17623 STARTUP THROUGH ENABLE
 $V_{IN} = 3.3V$, $V_{OUT} = 1.5V$, $I_{LOAD} = 1A$, MODE = PWM

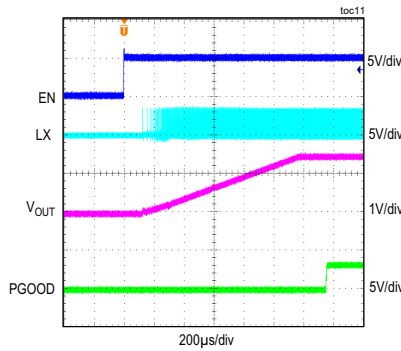

MAXM17623 SHUTDOWN THROUGH ENABLE
 $V_{IN} = 3.3V$, $V_{OUT} = 1.5V$, $I_{LOAD} = 1A$, MODE = PWM

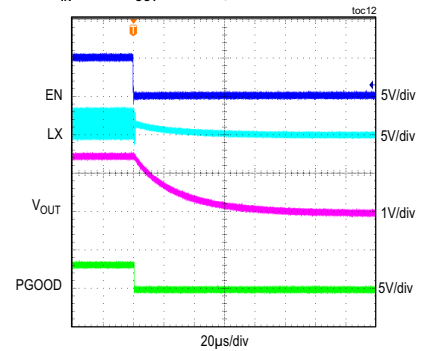

MAXM17624 STARTUP THROUGH ENABLE
 $V_{IN} = 5V$, $V_{OUT} = 3.3V$, $I_{LOAD} = 1A$, MODE = PWM

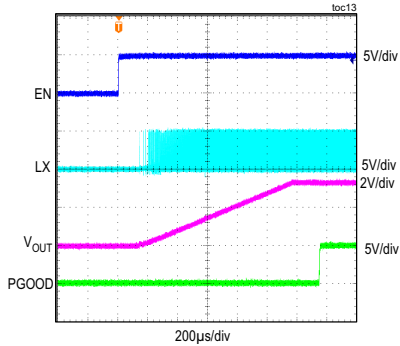

MAXM17624 SHUTDOWN THROUGH ENABLE
 $V_{IN} = 5V$, $V_{OUT} = 3.3V$, $I_{LOAD} = 1A$, MODE = PWM

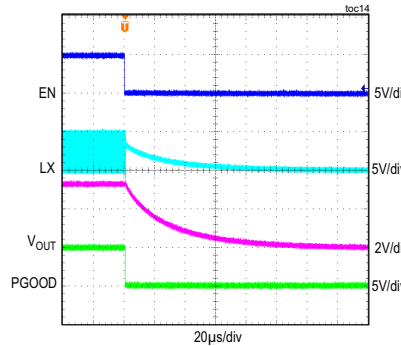

MAXM17623 TEMPORARY OUTPUT SHORT
 $V_{IN} = 3.3V$, $V_{OUT} = 1.5V$, $I_{LOAD} = 1A$, MODE = PWM

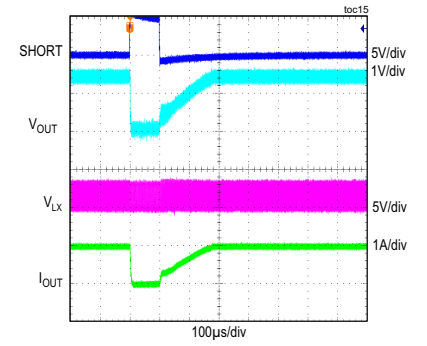

MAXM17624 TEMPORARY OUTPUT SHORT
 $V_{IN} = 5V$, $V_{OUT} = 3.3V$, $I_{LOAD} = 1A$, MODE = PWM

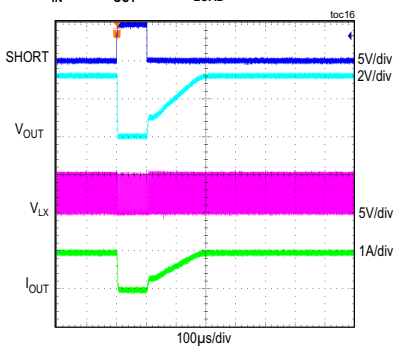

MAXM17623 STARTUP INTO PRE-BIAS
 $V_{IN} = 3.3V$, $V_{PREBIAS} = 0.8V$, $V_{OUT} = 1.5V$, $I_{OUT} = 1A$, PWM MODE

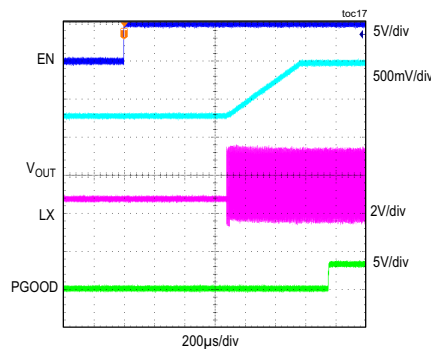

MAXM17624 STARTUP INTO PRE-BIAS
 $V_{IN} = 5V$, $V_{PREBIAS} = 2.5V$, $V_{OUT} = 3.3V$, $I_{LOAD} = 1A$, PWM MODE

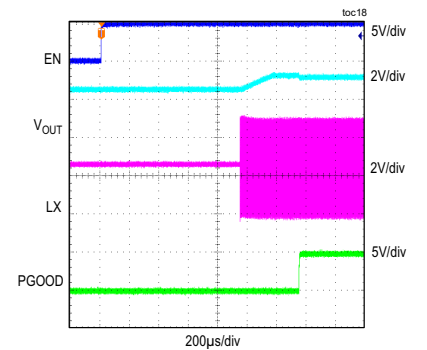

MAXM17623/MAXM17624 EV Kits Performance Report (continued)

($V_{IN} = V_{EN} = 5V$, $V_{SGND} = V_{PGND} = 0V$, $L_X = \text{Open}$, $T_A = -40^\circ\text{C}$ to $+125^\circ\text{C}$, unless otherwise noted. Typical values are at $T_A = +25^\circ\text{C}$. All voltages are referenced to $SGND$, unless otherwise noted.)

MAXM17623 OUTPUT VOLTAGE RIPPLE
 $V_{IN} = 3.3V$, $V_{OUT} = 1.5V$, $I_{LOAD} = 1A$, PWM MODE

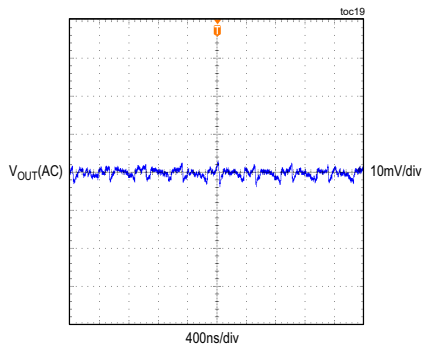

MAXM17624 OUTPUT VOLTAGE RIPPLE
 $V_{IN} = 5V$, $V_{OUT} = 3.3V$, $I_{LOAD} = 1A$, PWM MODE

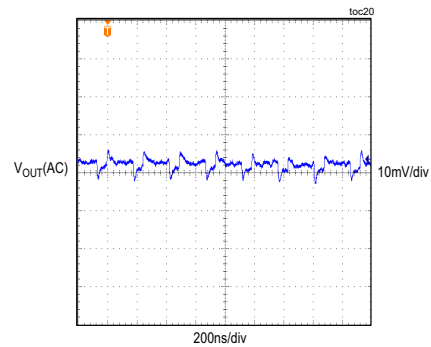

MAXM17623 OUTPUT VOLTAGE RIPPLE
 $V_{IN} = 3.3V$, $V_{OUT} = 1.5V$, $I_{LOAD} = 0A$, PFM MODE

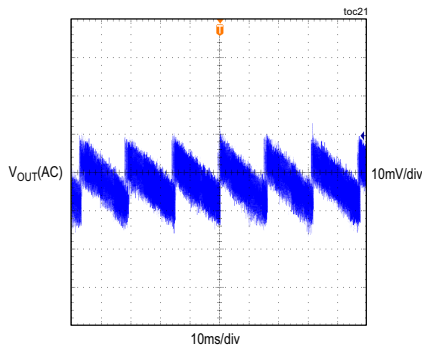

MAXM17624 OUTPUT VOLTAGE RIPPLE
 $V_{IN} = 5V$, $V_{OUT} = 3.3V$, $I_{LOAD} = 0A$, PFM MODE

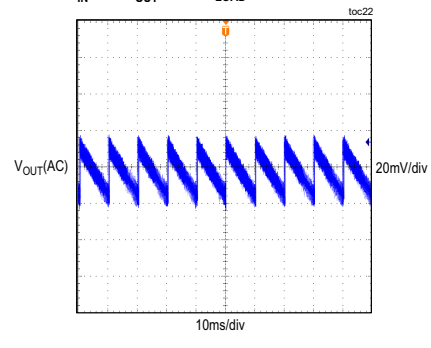

MAXM17623
OUTPUT CURRENT v/s AMBIENT TEMPERATURE
 $V_{IN} = 3.3V$, $V_{OUT} = 1.5V$

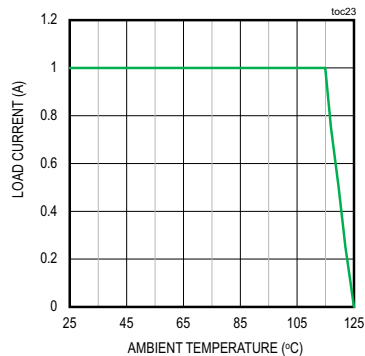

MAXM17624
OUTPUT CURRENT v/s AMBIENT TEMPERATURE
 $V_{IN} = 5V$, $V_{OUT} = 3.3V$

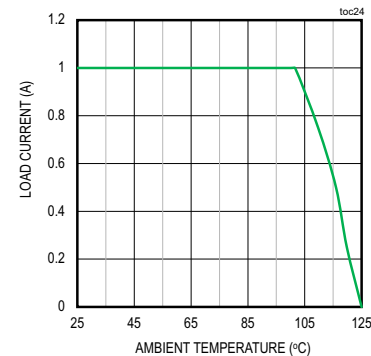

MAXM17623/MAXM17624 EV Kits Performance Report (continued)

(VIN = VEN = 5V, VSGND = VPGND = 0V, LX = Open, TA = -40°C to +125°C, unless otherwise noted. Typical values are at TA = +25°C. All voltages are referenced to SGND, unless otherwise noted.)

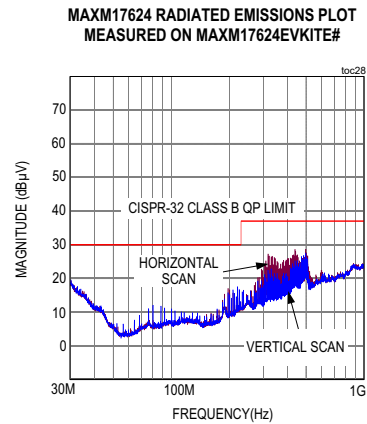
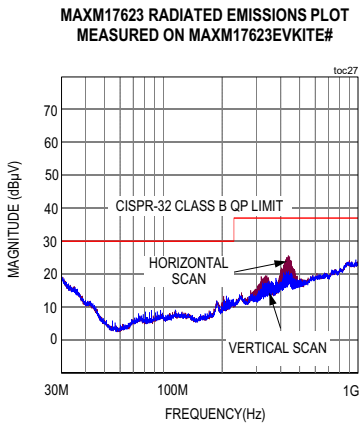
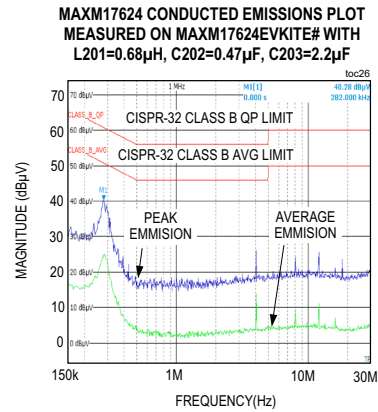
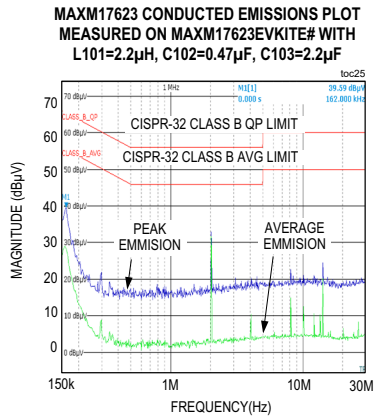

MAXM17623/MAXM17624 Evaluation Kit

Evaluates: MAXM17623/MAXM17624
Modules in Application

MAXM17623 EV Kit Bill of Materials

ITEM	QTY	DESIGNATOR	DESCRIPTION	MANUFACTURER PART NUMBER
1	3	C101, C106, C109	0.1 μ F \pm 10%, 10V, X7R, Ceramic Capacitor (0402)	TDK C1005X7R1C104K050BC
2	1	C104	47 μ F \pm 20%, 8V, Tantalum Capacitor (3528)	Kemet T520B476M008ATE035
3	1	C105	2.2 μ F \pm 10%, 10V, X7R, Ceramic Capacitor (0603)	Murata GRM188R71A225KE15
4	1	C107	220pF \pm 10%, 50V, X7R, Ceramic Capacitor (0402)	Murata GRM155R71H221KA01
5	1	C108	22 μ F \pm 10%, 6.3V, X7R, Ceramic Capacitor (0805)	Murata GRM21BZ70J226ME44
6	1	R101	100k Ω \pm 1%, Resistor (0402)	Panasonic ERJ-2RKF1003
7	1	R102	33.2k Ω \pm 1%, Resistor (0402)	Vishay CRCW04023322FK
8	1	R103	37.4k Ω \pm 1%, Resistor (0402)	Vishay CRCW040237K4FK
9	1	U101	MAXM17623 10pin u-SLIC Power Module	Maxim MAXM17623AMB+
10	1	C102	OPTIONAL: 0.47 μ F \pm 10%, 10V, X7R, Ceramic Capacitor (0603)	Murata GRM188R71A474KA61
11	1	C103	OPTIONAL: 2.2 μ F \pm 10%, 10V, X7R, Ceramic Capacitor (0603)	Murata GRM188R71A225KE15
12	1	L101	OPTIONAL: 2.2 μ H \pm 20%, 1.7A Shielded Wirewound Inductor	Murata DFE201610E-2R2M

MAXM17624 EV Kit Bill of Materials

ITEM	QTY	DESIGNATOR	DESCRIPTION	MANUFACTURER PART NUMBER
1	3	C201, C206, C209	0.1 μ F \pm 10%, 10V, X7R, Ceramic Capacitor (0402)	TDK C1005X7R1C104K050BC
2	1	C204	47 μ F \pm 20%, 8V, Tantalum Capacitor (3528)	Kemet T520B476M008ATE035
3	1	C205	2.2 μ F \pm 10%, 10V, X7R, Ceramic Capacitor (0603)	Murata GRM188R71A225KE15
4	1	C207	220pF \pm 10%, 50V, X7R, Ceramic Capacitor (0402)	Murata GRM155R71H221KA01
5	1	C208	10 μ F \pm 10%, 16V, X7R, Ceramic Capacitor (0805)	Murata GRM21BZ71C106KE15
6	1	R201	100k Ω \pm 1%, Resistor (0402)	Panasonic ERJ-2RKF1003
7	1	R202	118k Ω \pm 1%, Resistor (0402)	Panasonic ERJ-2RKF1183
8	1	R203	37.4k Ω \pm 1%, Resistor (0402)	Vishay CRCW040237K4FK
9	1	U201	MAXM17624 10pin u-SLIC Power Module	Maxim MAXM17624AMB+
10	1	C202	OPTIONAL: 0.47 μ F \pm 10%, 10V, X7R, Ceramic Capacitor (0603)	Murata GRM188R71A474KA61
11	1	C203	OPTIONAL: 2.2 μ F \pm 10%, 10V, X7R, Ceramic Capacitor (0603)	Murata GRM188R71A225KE15
12	1	L201	OPTIONAL: 0.68 μ H \pm 20%, 2.7A Shielded Wirewound Inductor	Murata DFE201610E-R68M

MAXM17623/MAXM17624 Evaluation Kit

Evaluates: MAXM17623/MAXM17624 Modules in Application

MAXM17623 EV Kit Schematic

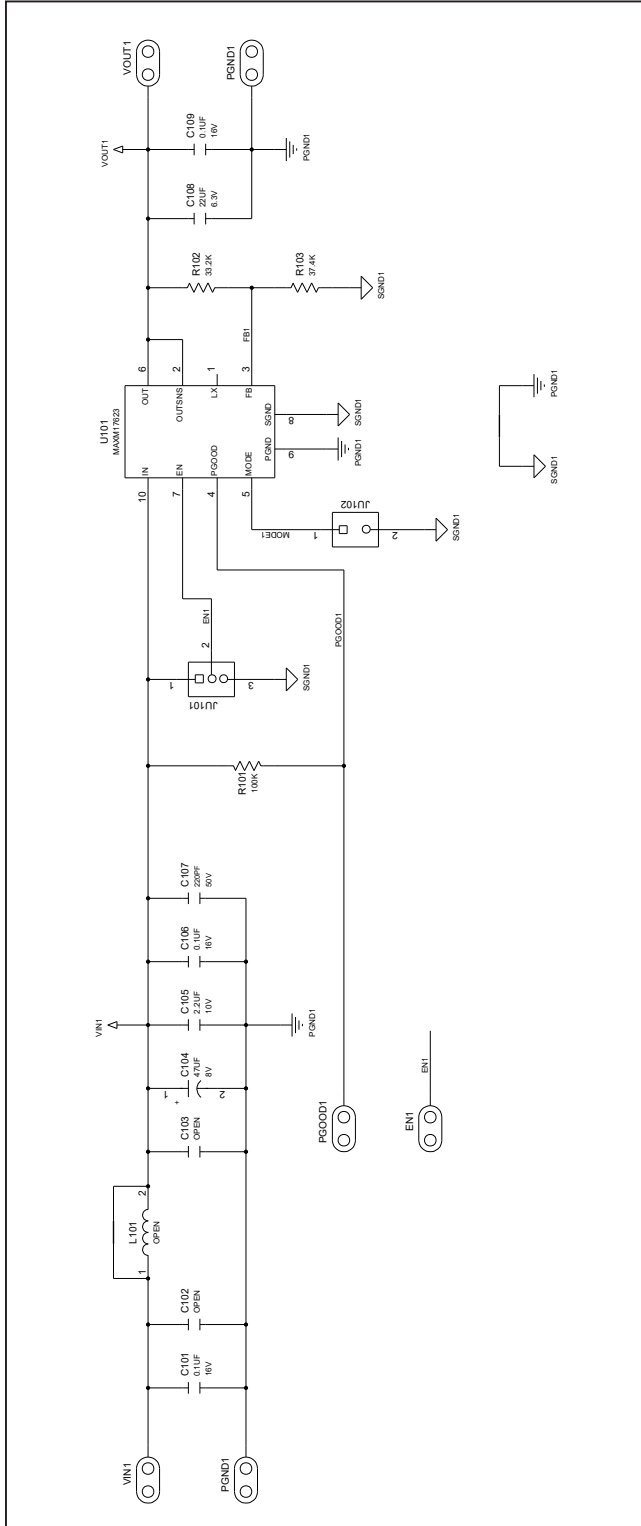

MAXM17624 EV Kit Schematic

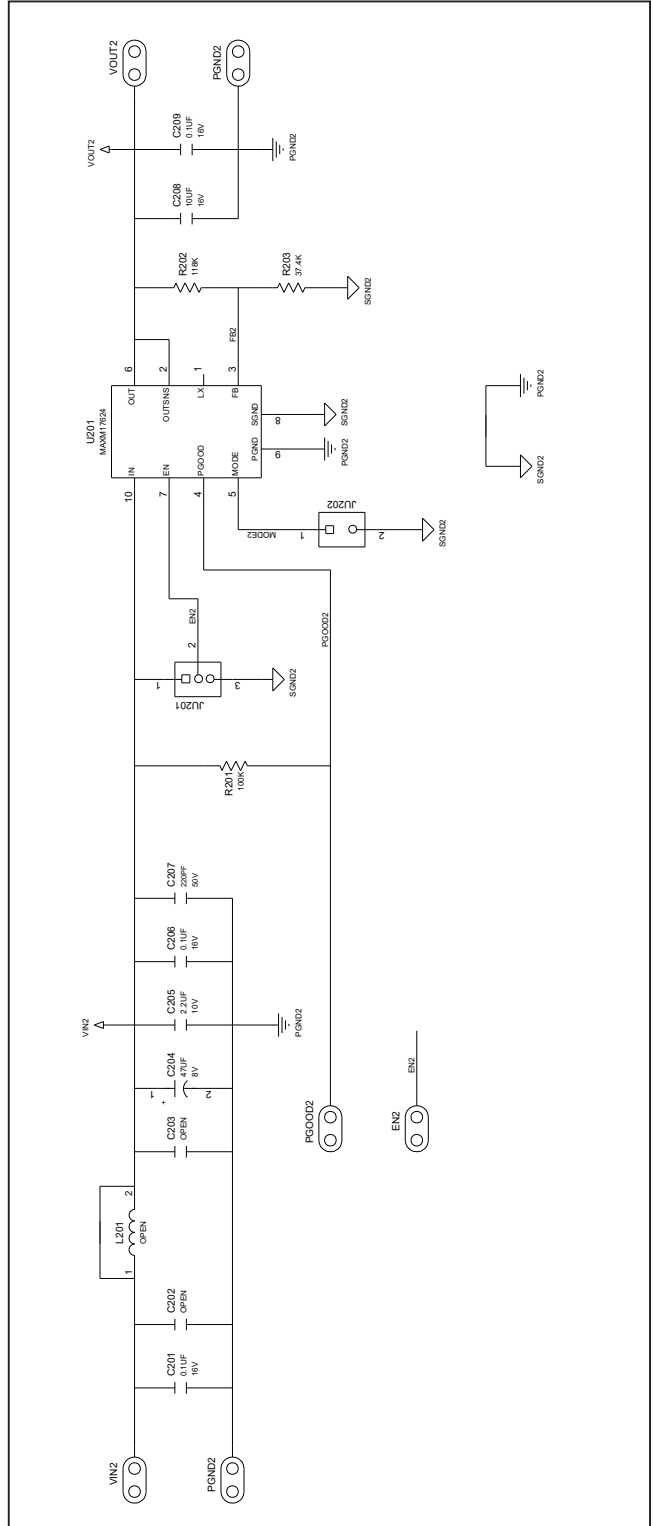

**MAXM17623/MAXM17624
Evaluation Kit**

Evaluates: MAXM17623/MAXM17624
Modules in Application

MAXM17623/MAXM17624 EV Kits PCB Layout Diagrams

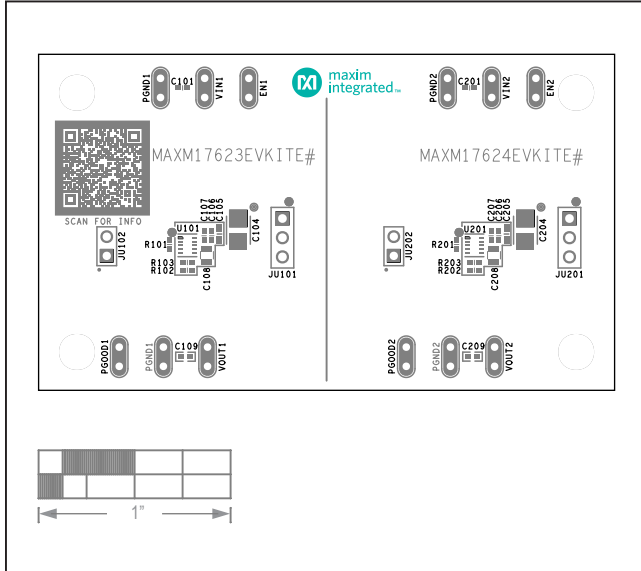

MAXM17623/MAXM17624 EV Kits PCB Layout-Top Silkscreen

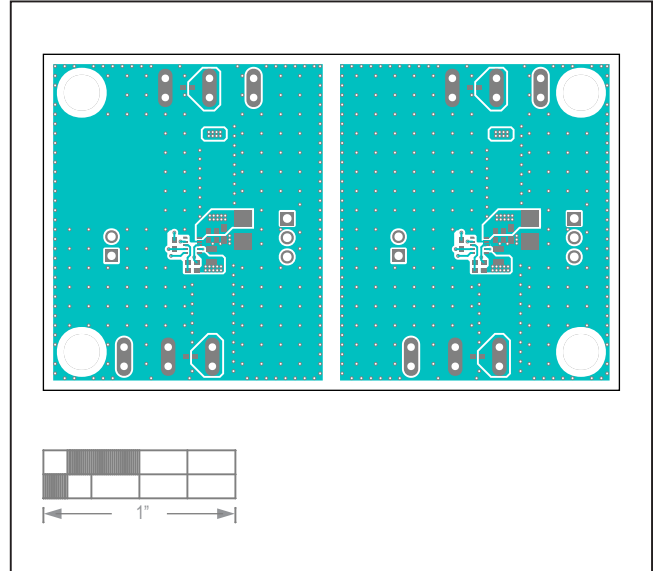

MAXM17623/MAXM17624 EV Kits PCB Layout-Top Layer

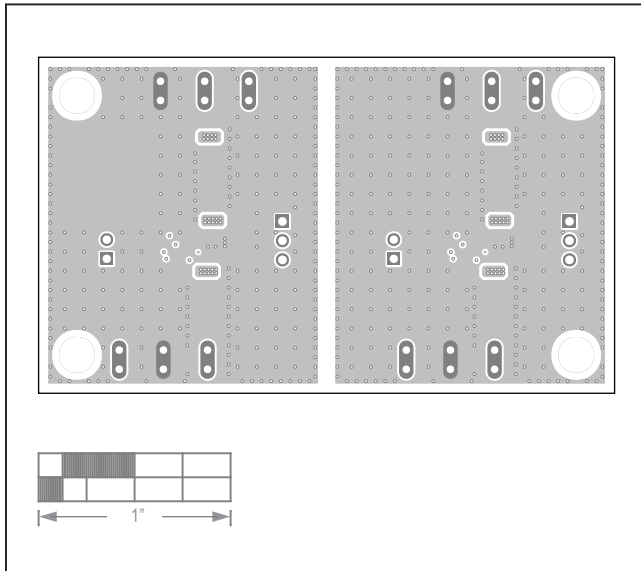

MAXM17623/MAXM17624 EV Kits PCB Layout-Layer 2

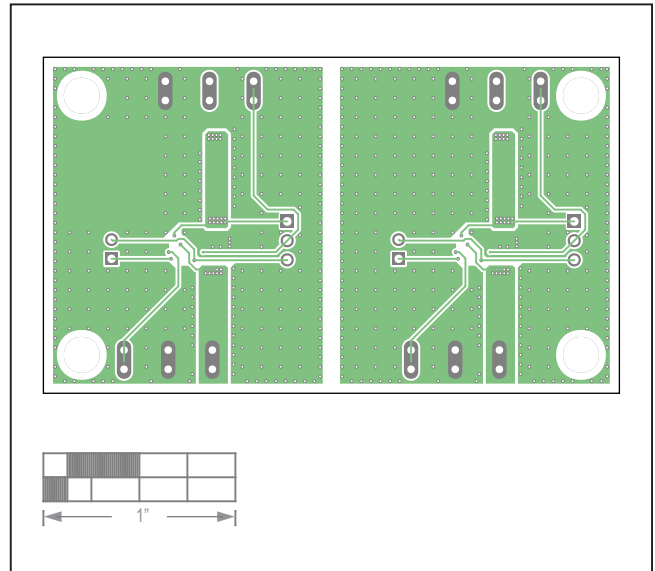

MAXM17623/MAXM17624 EV Kits PCB Layout-Layer 3

MAXM17623/MAXM17624 Evaluation Kit

Evaluates: MAXM17623/MAXM17624
Modules in Application

MAXM17623/MAXM17624 EV Kits PCB Layout Diagrams (continued)

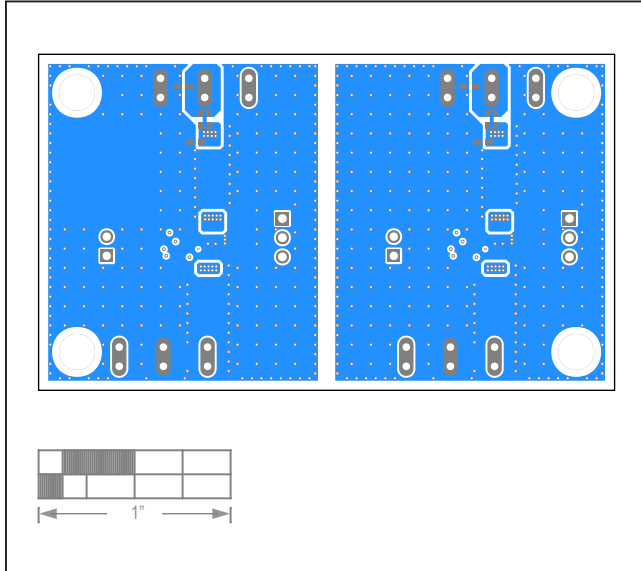

MAXM17623/MAXM17624 EV Kits PCB Layout–Bottom Layer

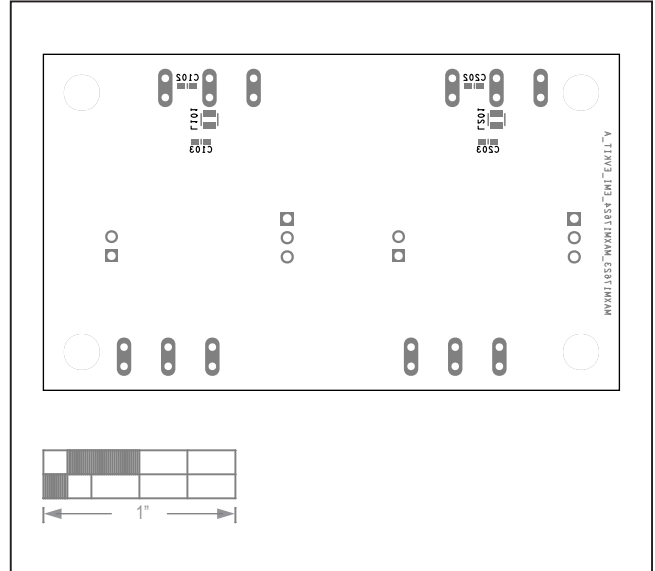

MAXM17623/MAXM17624 EV Kits PCB Layout–Bottom Silkscreen