

**SINGLE-PHASE GLASS PASSIVATED
SILICON BRIDGE RECTIFIER**
VOLTAGE RANGE 50 to 1000 Volts CURRENT 25 Amperes

FEATURES

- * Superior thermal desing
- * 300 amperes surge rating
- * 1/4" universal faston terminal
- * Hole thru for #8 screw

MECHANICAL DATA

- * Epoxy : Device has UL flammability classification 94V-0
- * UL listed the recongnized component director, file #94233

DISCONTINUED-

"This series is replaced by the MP25 series that meets to the same fit and function parameters.
The MP25 series is preferred for PCB assembly."

MAXIMUM RATINGS AND ELECTRICAL CHARACTERISTICS

Ratings at 25 °C ambient temperature unless otherwise specified.
Single phase, half wave, 60 Hz, resistive or inductive load.
For capacitive load, derate current by 20%.

Discontinued



MB-25



MB-25W

MAXIMUM RATINGS (@ TA=25 °C unless otherwise noted)

RATINGS	SYMBOL	MB2505	MB251	MB252	MB254	MB256	MB258	MB2510	UNITS	
Maximum Recurrent Peak Reverse Voltage	V _{RRM}	50	100	200	400	600	800	1000	Volts	
Maximum RMS Voltage	V _{RMS}	35	70	140	280	420	560	700	Volts	
Maximum DC Blocking Voltage	V _{DC}	50	100	200	400	600	800	1000	Volts	
Maximum Average Forward Rectified Current at T _C = 55°C	I _O	25.0								Amps
Peak Forward Surge Current 8.3 ms single half sine-wave superimposed on rated load (JEDEC method)	I _{FSM}	300								Amps
Typical Thermal Resistance (Note 2)	R _{θJC}	4								°C/W
	R _{θJA}	16								
Operating and Storage Temperature Range	T _J , T _{STG}	-55 to + 150								°C

ELECTRICAL CHARACTERISTICS(@TA=25 °C unless otherwise noted)

CHARACTERISTICS	SYMBOL	MB2505	MB251	MB252	MB254	MB256	MB258	MB2510	UNITS	
Maximum Instantaneous Forward Voltage at 12.5ADC	V _F	1.1								Volts
Maximum DC Reverse Current at Rated DC Blocking Voltage	@T _A = 25°C	5.0								uAmps
	@T _A = 100°C	500								

- NOTES : 1. Suffix "W" for wire type.
2. Typical Thermal Resistance: Heat-sink case mounted.
3. "Fully ROHS compliant", "100% Sn plating (Pb-free)".

RATING AND CHARACTERISTICS CURVES (MB2505 THRU MB2510)

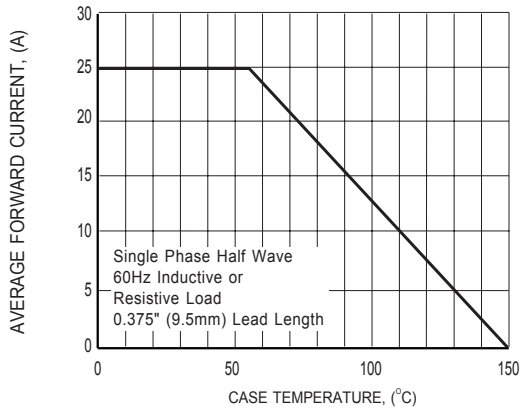

FIG.1 TYPICAL FORWARD CURRENT DERATING CURVE

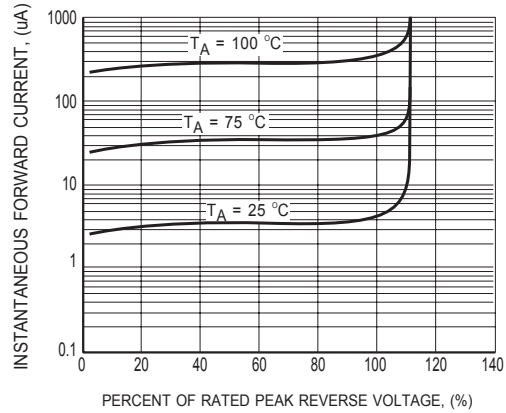

FIG.2 TYPICAL REVERSE CHARACTERISTICS

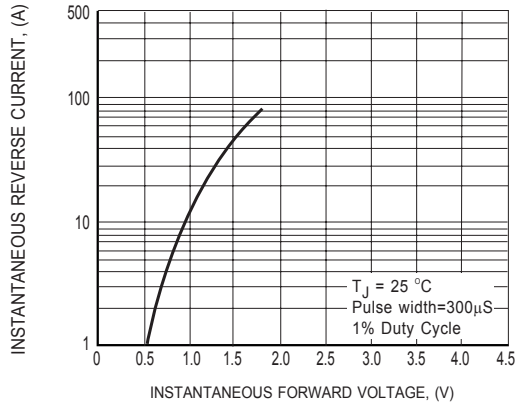

FIG.3 TYPICAL INSTANTANEOUS FORWARD CHARACTERISTICS

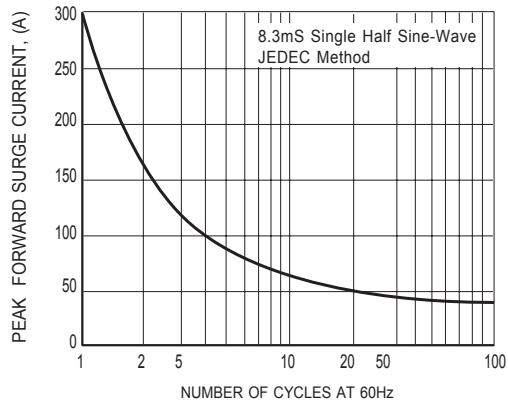
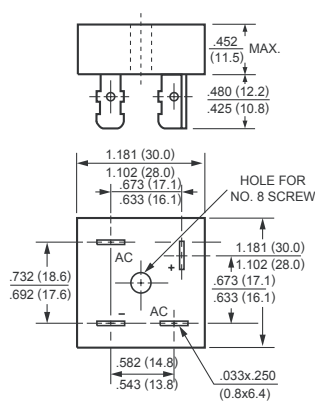
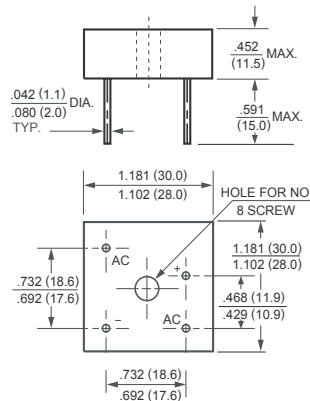

FIG.4 MAXIMUM NON-REPETITIVE FORWARD SURGE CURRENT



MB-25



MB-25W