



# MBR1640DC~MBR16200DC

## D<sup>2</sup>PAK SURFACE SCHOTTKY BARRIER RECTIFIERS

**VOLTAGE** 40 to 200 Volt **CURRENT** 16 Ampere

**TO-263 / D<sup>2</sup>PAK**

Unit : inch(mm)

### FEATURES

- Plastic package has Underwriters Laboratory Flammability Classification 94V-O utilizing Flame Retardant Epoxy Molding Compound.
- Low power loss, high efficiency.
- Low forward voltage, high current capability
- High surge capacity.
- For use in low voltage,high frequency inverters free wheeling , and polarity protection applications.
- Lead free in compliance with EU RoHS 2.0
- Green molding compound as per IEC 61249 standard

### MECHANICAL DATA

- Case: D<sup>2</sup>PAK/TO-263 molded plastic package
- Terminals: Lead solderable per MIL-STD-750, Method 2026
- Polarity: As marked.
- Weight: 0.049 ounces, 1.38 grams

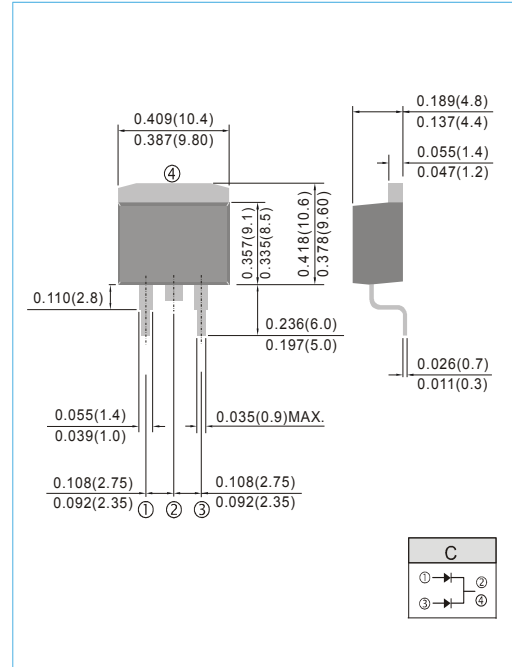

### MAXIMUM RATINGS

Ratings at 25°C ambient temperature unless otherwise specified. Single phase, half wave, 60 Hz, resistive or inductive load. For capacitive load, derate current by 20%

PARAMETER	SYMBOL	MBR1640DC	MBR1645DC	MBR1650DC	MBR1660DC	MBR1680DC	MBR1690DC	MBR16100DC	MBR16150DC	MBR16200DC	UNITS	
Maximum Recurrent Peak Reverse Voltage	$V_{RRM}$	40	45	50	60	80	90	100	150	200	V	
Maximum RMS Voltage	$V_{RMS}$	28	31.5	35	42	56	63	70	105	140	V	
Maximum DC Blocking Voltage	$V_{DC}$	40	45	50	60	80	90	100	150	200	V	
Maximum Average Forward (See Figure 1)	$I_{F(AV)}$	16									A	
Peak Forward Surge Current : 8.3ms single half sine-wave superimposed on rated load	$I_{FSM}$	150									A	
Maximum Forward Voltage at 8.0A per leg	$V_F$	0.70		0.75		0.80			0.90		V	
Maximum DC Reverse Current at Rated DC Blocking Voltage $T_J=25^{\circ}C$ $T_J=100^{\circ}C$	$I_R$						0.05 20					mA
Typical Thermal Resistance	$R_{\theta JC}$						2.0					$^{\circ}C / W$
Operating Junction and Storage Temperature Range	$T_J, T_{STG}$	-55 to +150									-65 to +175	$^{\circ}C$



# MBR1640DC~MBR16200DC

## RATING AND CHARACTERISTIC CURVES

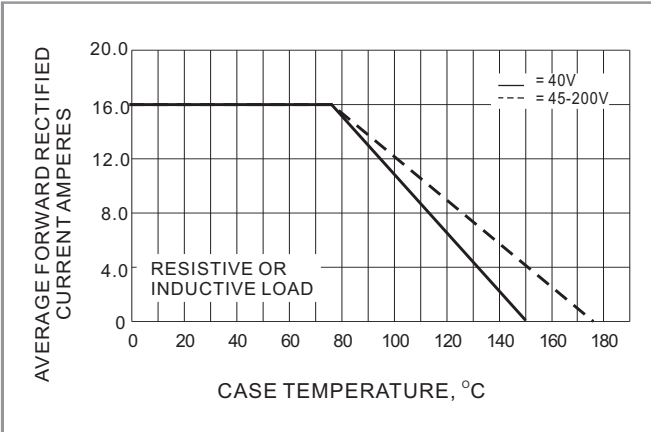

Fig.1 FORWARD CURRENT DERATING CURVE

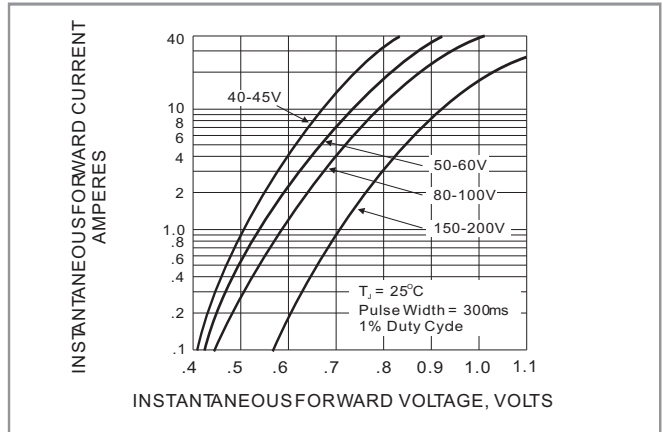

Fig.2 TYPICAL INSTANTANEOUS FORWARD CHARACTERISTICS

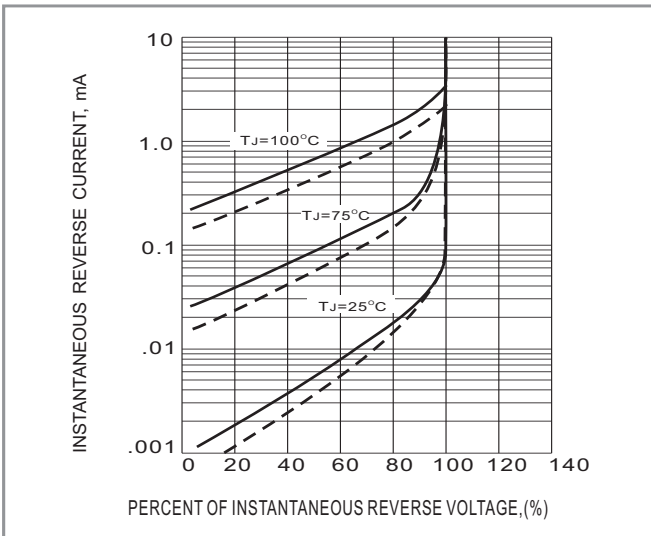

Fig.3 TYPICAL REVERSE CHARACTERISTICS

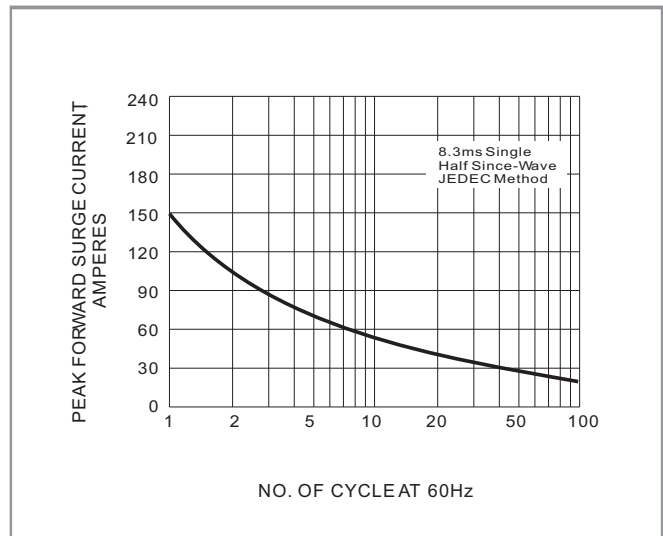

Fig.4 MAXIMUM NON-REPETITIVE SURGE CURRENT

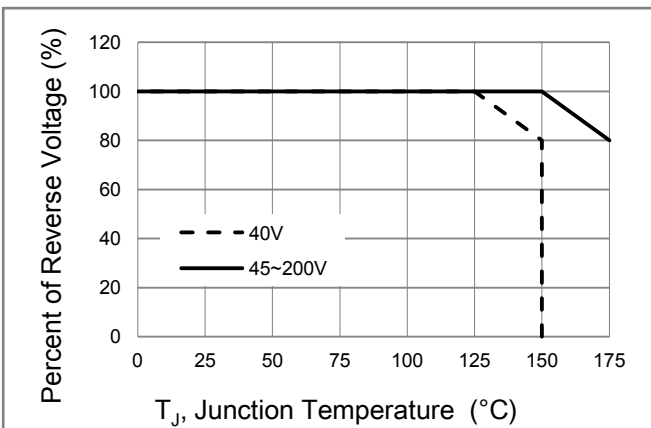

Fig.5 Operating Temperature Derating Curve



## MBR1640DC~MBR16200DC

### MOUNTING PAD LAYOUT

TO-263 / D<sup>2</sup>PAK

Unit : inch(mm)

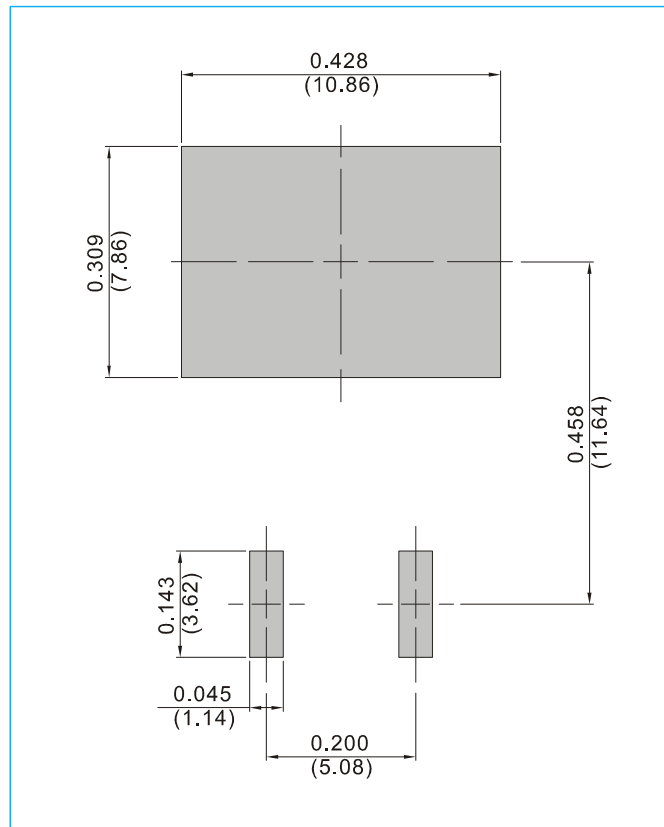

### ORDER INFORMATION

- Packing information  
T/R - 0.8K per 13" plastic Reel



## MBR1640DC~MBR16200DC

Part No\_packing code\_Version

MBR1640DC\_R2\_00001

For example :

RB500V-40\_R2\_00001



Packing type	Packing Code <b>XX</b>			Version Code <b>XXXXX</b>		
	1 <sup>st</sup> Code	Packing size code	2 <sup>nd</sup> Code	HF or RoHS	1 <sup>st</sup> Code	2 <sup>nd</sup> ~5 <sup>th</sup> Code
Tape and Ammunition Box (T/B)	<b>A</b>	N/A	<b>0</b>	<b>HF</b>	<b>0</b>	serial number
Tape and Reel (T/R)	<b>R</b>	7"	<b>1</b>	<b>RoHS</b>	<b>1</b>	serial number
Bulk Packing (B/P)	<b>B</b>	13"	<b>2</b>			
Tube Packing (T/P)	<b>T</b>	26mm	<b>X</b>			
Tape and Reel (Right Oriented) (TRR)	<b>S</b>	52mm	<b>Y</b>			
Tape and Reel (Left Oriented) (TRL)	<b>L</b>	PANASERT T/B CATHODE UP (PBCU)	<b>U</b>			
FORMING	<b>F</b>	PANASERT T/B CATHODE DOWN (PBCD)	<b>D</b>			