

# MC14528B

## Dual Monostable Multivibrator

The MC14528B is a dual, retriggerable, resettable monostable multivibrator. It may be triggered from either edge of an input pulse, and produces an output pulse over a wide range of widths, the duration of which is determined by the external timing components,  $C_X$  and  $R_X$ .

### Features

- Separate Reset Available
- Diode Protection on All Inputs
- Triggerable from Leading or Trailing Edge Pulse
- Supply Voltage Range = 3.0 Vdc to 18 Vdc
- Capable of Driving Two Low-power TTL Loads or One Low-power Schottky TTL Load Over the Rated Temperature Range
- This part should only be used in new designs where the pulse width is  $< 10 \mu\text{s}$   
 Note: For designs requiring a pulse width  $> 10 \mu\text{s}$ , please see MC14538, which is pin-for-pin compatible
- NLV Prefix for Automotive and Other Applications Requiring Unique Site and Control Change Requirements; AEC-Q100 Qualified and PPAP Capable
- This Device is Pb-Free and is RoHS Compliant

### MAXIMUM RATINGS (Voltages Referenced to $V_{SS}$ )

Rating	Symbol	Value	Unit
DC Supply Voltage Range	$V_{DD}$	-0.5 to +18.0	V
Input or Output Voltage Range (DC or Transient)	$V_{in}, V_{out}$	-0.5 to $V_{DD} + 0.5$	V
Input or Output Current (DC or Transient) per Pin	$I_{in}, I_{out}$	$\pm 10$	mA
Power Dissipation, per Package (Note 1)	$P_D$	500	mW
Ambient Temperature Range	$T_A$	-55 to +125	$^{\circ}\text{C}$
Storage Temperature Range	$T_{stg}$	-65 to +150	$^{\circ}\text{C}$
Lead Temperature (8-Second Soldering)	$T_L$	260	$^{\circ}\text{C}$

Stresses exceeding those listed in the Maximum Ratings table may damage the device. If any of these limits are exceeded, device functionality should not be assumed, damage may occur and reliability may be affected.

1. Temperature Derating: "D/DW" Package:  $-7.0 \text{ mW}/^{\circ}\text{C}$  From  $65^{\circ}\text{C}$  To  $125^{\circ}\text{C}$

This device contains protection circuitry to guard against damage due to high static voltages or electric fields. However, precautions must be taken to avoid applications of any voltage higher than maximum rated voltages to this high-impedance circuit. For proper operation,  $V_{in}$  and  $V_{out}$  should be constrained to the range  $V_{SS} \leq (V_{in} \text{ or } V_{out}) \leq V_{DD}$ .

Unused inputs must always be tied to an appropriate logic voltage level (e.g., either  $V_{SS}$  or  $V_{DD}$ ). Unused outputs must be left open.



ON Semiconductor®

<http://onsemi.com>



SOIC-16  
D SUFFIX  
CASE 751B

### PIN ASSIGNMENT



### MARKING DIAGRAM

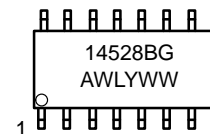

A = Assembly Location  
 WL = Wafer Lot  
 YY, Y = Year  
 WW, W = Work Week  
 G = Pb-Free Package

### ORDERING INFORMATION

See detailed ordering and shipping information in the package dimensions section on page 5 of this data sheet.

# MC14528B

## ONE-SHOT SELECTION GUIDE

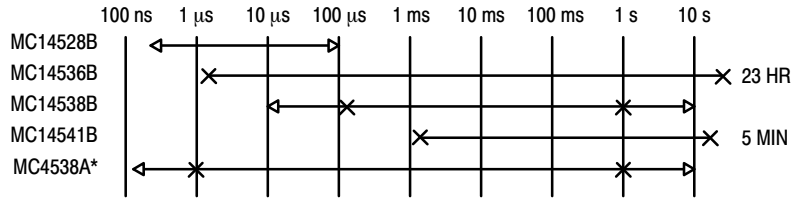

\*LIMITED OPERATING VOLTAGE (2-6 V)

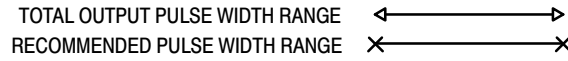

## BLOCK DIAGRAM

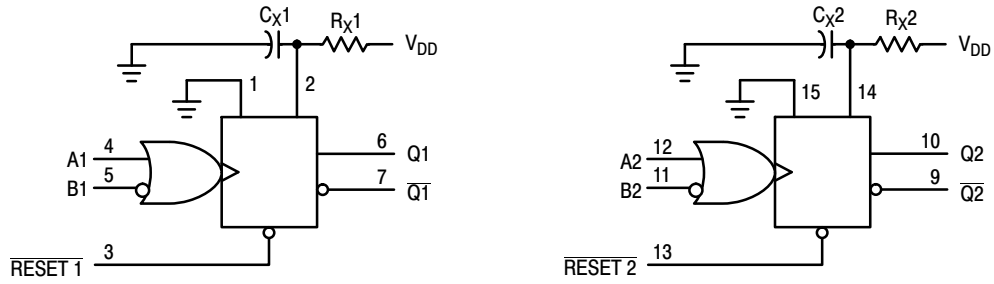

$V_{DD}$  = PIN 16  
 $V_{SS}$  = PIN 1, PIN 8, PIN 15  
 $R_x$  AND  $C_x$  ARE EXTERNAL COMPONENTS

## FUNCTION TABLE

Reset	Inputs		Outputs	
	A	B	Q	$\bar{Q}$
H		H		
H	L			
H		L	Not Triggered	Not Triggered
H	H		Not Triggered	Not Triggered
H	L, H,	H	Not Triggered	Not Triggered
H	L	L, H,	Not Triggered	Not Triggered
L	X	X	L	H
	X	X	Not Triggered	Not Triggered

# MC14528B

## ELECTRICAL CHARACTERISTICS (Voltages Referenced to V<sub>SS</sub>)

Characteristic	Symbol	V <sub>DD</sub> Vdc	- 55° C		25° C			125° C		Unit
			Min	Max	Min	Typ (Note 2)	Max	Min	Max	
Output Voltage "0" Level V <sub>in</sub> = V <sub>DD</sub> or 0	V <sub>OL</sub>	5.0	-	0.05	-	0	0.05	-	0.05	Vdc
		10	-	0.05	-	0	0.05	-	0.05	
15		-	0.05	-	0	0.05	-	0.05		
"1" Level V <sub>in</sub> = 0 or V <sub>DD</sub>	V <sub>OH</sub>	5.0	4.95	-	4.95	5.0	-	4.95	-	Vdc
		10	9.95	-	9.95	10	-	9.95	-	
		15	14.95	-	14.95	15	-	14.95	-	
Input Voltage "0" Level (V <sub>O</sub> = 4.5 or 0.5 Vdc) (V <sub>O</sub> = 9.0 or 1.0 Vdc) (V <sub>O</sub> = 13.5 or 1.5 Vdc)	V <sub>IL</sub>	5.0	-	1.5	-	2.25	1.5	-	1.5	Vdc
		10	-	3.0	-	4.50	3.0	-	3.0	
		15	-	4.0	-	6.75	4.0	-	4.0	
"1" Level (V <sub>O</sub> = 0.5 or 4.5 Vdc) (V <sub>O</sub> = 1.0 or 9.0 Vdc) (V <sub>O</sub> = 1.5 or 13.5 Vdc)	V <sub>IH</sub>	5.0	3.5	-	3.5	2.75	-	3.5	-	Vdc
		10	7.0	-	7.0	5.50	-	7.0	-	
		15	11	-	11	8.25	-	11	-	
Output Drive Current (V <sub>OH</sub> = 2.5 Vdc) (V <sub>OH</sub> = 4.6 Vdc) (V <sub>OH</sub> = 9.5 Vdc) (V <sub>OH</sub> = 13.5 Vdc)	Source I <sub>OH</sub>	5.0	-1.2	-	-1.0	-1.7	-	-0.7	-	mAdc
		5.0	-0.64	-	-0.51	-0.88	-	-0.36	-	
		10	-1.6	-	-1.3	-2.25	-	-0.9	-	
		15	-4.2	-	-3.4	-8.8	-	-2.4	-	
(V <sub>OL</sub> = 0.4 Vdc) (V <sub>OL</sub> = 0.5 Vdc) (V <sub>OL</sub> = 1.5 Vdc)	Sink I <sub>OL</sub>	5.0	0.64	-	0.51	0.88	-	0.36	-	mAdc
		10	1.6	-	1.3	2.25	-	0.9	-	
		15	4.2	-	3.4	8.8	-	2.4	-	
Input Current	I <sub>in</sub>	15	-	±0.1	-	±0.00001	±0.1	-	±1.0	μAdc
Input Capacitance (V <sub>in</sub> = 0)	C <sub>in</sub>	-	-	-	-	5.0	7.5	-	-	pF
Quiescent Current (Per Package)	I <sub>DD</sub>	5.0	-	5.0	-	0.005	5.0	-	150	μAdc
		10	-	10	-	0.010	10	-	300	
		15	-	20	-	0.015	20	-	600	
Total Supply Current at an external load Capacitance (C <sub>L</sub> ) and at external timing capacitance (C <sub>X</sub> ), use the formula. (Note 3)	I <sub>T</sub>	-	$I_T(C_L, C_X) = [(C_L + 0.36C_X)V_{DD}f + 2 \times 10^{-8} R_X C_X (V_{DD}^{-2})^2 f] \times 10^{-3}$ where: I <sub>T</sub> in μA (per circuit), C <sub>L</sub> and C <sub>X</sub> in pF, R <sub>X</sub> in megohms, V <sub>DD</sub> in Vdc, f in kHz is input frequency.							μAdc

Product parametric performance is indicated in the Electrical Characteristics for the listed test conditions, unless otherwise noted. Product performance may not be indicated by the Electrical Characteristics if operated under different conditions.

2. Data labelled "Typ" is not to be used for design purposes but is intended as an indication of the IC's potential performance.

3. The formulas given are for the typical characteristics only at 25°C.

# MC14528B

## SWITCHING CHARACTERISTICS ( $C_L = 50 \text{ pF}$ , $T_A = 25^\circ\text{C}$ ) (Note 4)

Characteristic	Symbol	$C_X$ pF	$R_X$ k $\Omega$	$V_{DD}$ Vdc	Min	Typ (Note 5)	Max	Unit
Output Rise and Fall Time $t_{TLH}$ , $t_{THL} = (1.5 \text{ ns/pF}) C_L + 25 \text{ ns}$ $t_{TLH}$ , $t_{THL} = (0.75 \text{ ns/pF}) C_L + 12.5 \text{ ns}$ $t_{TLH}$ , $t_{THL} = (0.55 \text{ ns/pF}) C_L + 9.5 \text{ ns}$	$t_{TLH}$ , $t_{THL}$	–	–	5.0 10 15	– – –	100 50 40	200 100 80	ns
Turn-Off, Turn-On Delay Time — A or B to Q or $\bar{Q}$ $t_{PLH}$ , $t_{PHL} = (1.7 \text{ ns/pF}) C_L + 240 \text{ ns}$ $t_{PLH}$ , $t_{PHL} = (0.66 \text{ ns/pF}) C_L + 87 \text{ ns}$ $t_{PLH}$ , $t_{PHL} = (0.5 \text{ ns/pF}) C_L + 65 \text{ ns}$	$t_{PLH}$ , $t_{PHL}$	15	5.0	5.0 10 15	– – –	325 120 90	650 240 180	ns
Turn-Off, Turn-On Delay Time — A or B to Q or $\bar{Q}$ $t_{PLH}$ , $t_{PHL} = (1.7 \text{ ns/pF}) C_L + 620 \text{ ns}$ $t_{PLH}$ , $t_{PHL} = (0.66 \text{ ns/pF}) C_L + 257 \text{ ns}$ $t_{PLH}$ , $t_{PHL} = (0.5 \text{ ns/pF}) C_L + 185 \text{ ns}$	$t_{PLH}$ , $t_{PHL}$	1000	10	5.0 10 15	– – –	705 290 210	– – –	ns
Input Pulse Width — A or B	$t_{WH}$	15	5.0	5.0 10 15	150 75 55	70 30 30	– – –	ns
		1000	10	5.0 10 15	– – –	70 30 30	– – –	ns
Output Pulse Width — Q or $\bar{Q}$ (For $C_X < 0.01 \mu\text{F}$ use graph for appropriate $V_{DD}$ level.)	$t_W$	15	5.0	5.0 10 15	– – –	550 350 300	– – –	ns
Output Pulse Width — Q or $\bar{Q}$ (For $C_X > 0.01 \mu\text{F}$ use formula: $t_W = 0.2 R_X C_X \ln [V_{DD} - V_{SS}]$ ) (Note 6)	$t_W$	10,000	10	5.0 10 15	15 10 15	30 50 55	45 90 95	$\mu\text{s}$
Pulse Width Match between Circuits in the same package	$t_1 - t_2$	10,000	10	5.0 10 15	– – –	6.0 8.0 8.0	25 35 35	%
Reset Propagation Delay — $\bar{\text{Reset}}$ to Q or $\bar{Q}$	$t_{PLH}$ , $t_{PHL}$	15	5.0	5.0 10 15	– – –	325 90 60	600 225 170	ns
		1000	10	5.0 10 15	– – –	1000 300 250	– – –	ns
Retrigger Time	$t_{rr}$	15	5.0	5.0 10 15	0 0 0	– – –	– – –	ns
		1000	10	5.0 10 15	0 0 0	– – –	– – –	ns
External Timing Resistance	$R_X$	–	–	–	5.0	–	1000	k $\Omega$
External Timing Capacitance	$C_X$	–	–	–	No Limits (Note 7)			$\mu\text{F}$

4. The formulas given are for the typical characteristics only at  $25^\circ\text{C}$ .

5. Data labelled "Typ" is not to be used for design purposes but is intended as an indication of the IC's potential performance.

6. If  $C_X > 15 \mu\text{F}$ , Use Discharge Protection Diode  $D_X$ , per Figure 9.

7.  $R_X$  is in  $\Omega$ ,  $C_X$  is in farads,  $V_{DD}$  and  $V_{SS}$  in volts,  $PW_{out}$  in seconds.

# MC14528B

## ORDERING INFORMATION

Device	Package	Shipping†
MC14528BDG	SOIC-16 (Pb-Free)	48 Units / Rail
MC14528BDR2G	SOIC-16 (Pb-Free)	2500 / Tape & Reel
NLV14528BDR2G*	SOIC-16 (Pb-Free)	2500 / Tape & Reel

†For information on tape and reel specifications, including part orientation and tape sizes, please refer to our Tape and Reel Packaging Specifications Brochure, BRD8011/D.

\*NLV Prefix for Automotive and Other Applications Requiring Unique Site and Control Change Requirements; AEC-Q100 Qualified and PPAP Capable.

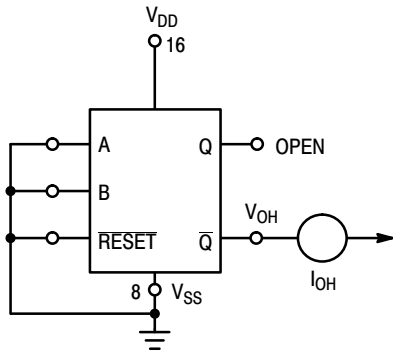

Figure 1. Output Source Current Test Circuit

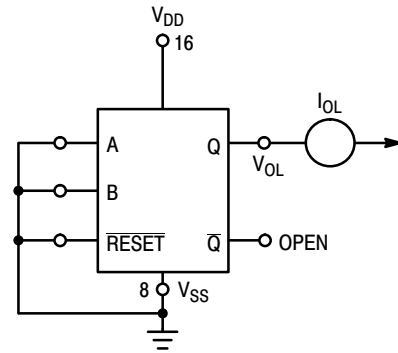

Figure 2. Output Sink Current Test Circuit

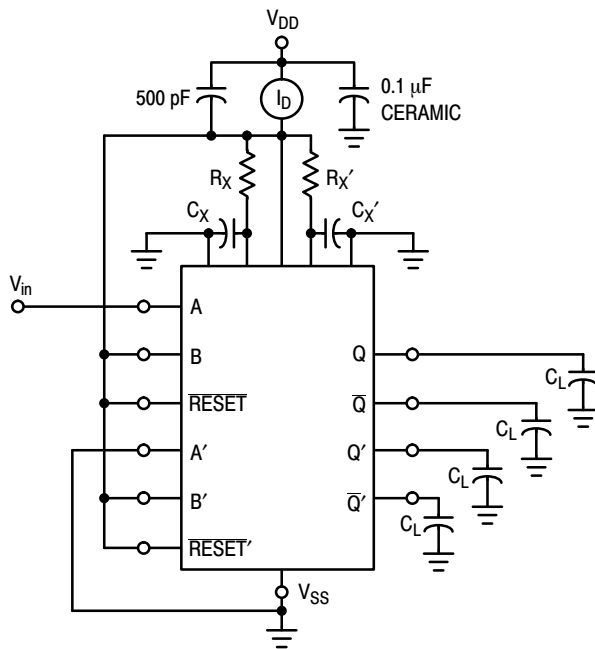

Figure 3. Power Dissipation Test Circuit and Waveforms

# MC14528B



## INPUT CONNECTIONS

Characteristics	Reset	A	B
$t_{PLH}, t_{PHL}, t_{TLH}, t_{THL}, t_W$	$V_{DD}$	PG1	$V_{DD}$
$t_{PLH}, t_{PHL}, t_{TLH}, t_{THL}, t_W$	$V_{DD}$	$V_{SS}$	PG2
$t_{PLH(R)}, t_{PHL(R)}, t_W$	PG3	PG1	PG2

\*Includes capacitance of probes, wiring, and fixture parasitic.

NOTE: AC test waveforms for PG1, PG2, and PG3 on next page.



Figure 4. AC Test Circuit

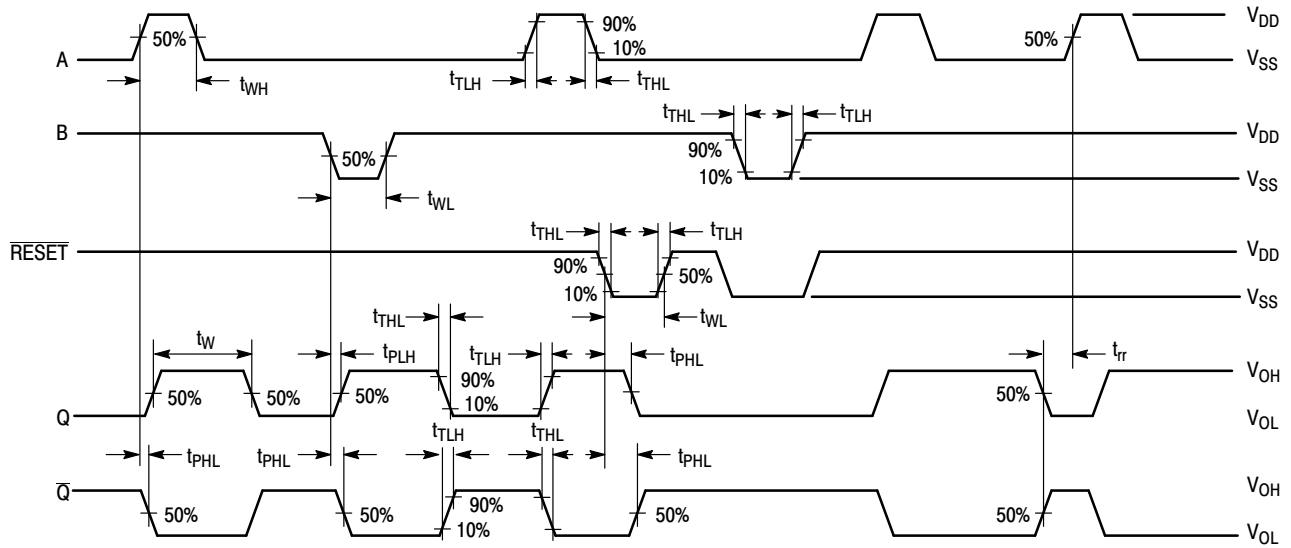

Figure 5. AC Test Waveforms

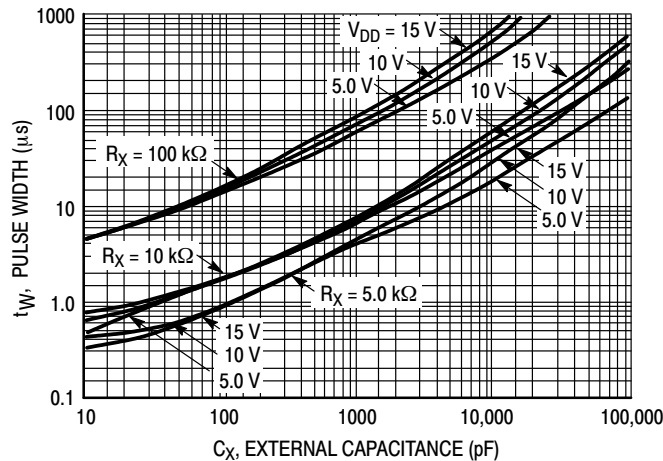
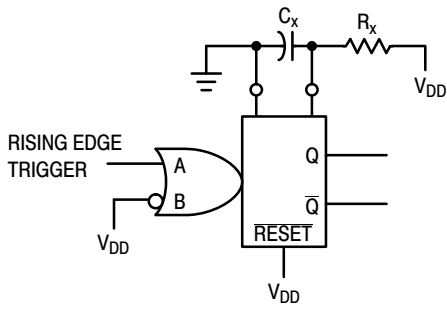

Figure 6. Pulse Width versus  $C_X$

# MC14528B

## TYPICAL APPLICATIONS



**Figure 7. Retriggerable Monostables Circuitry**

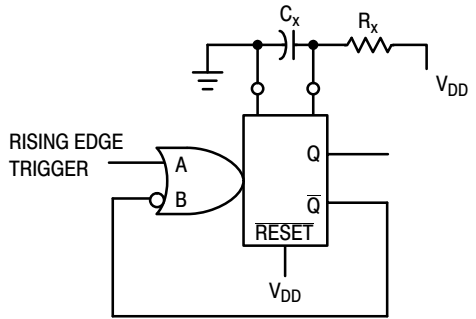

**Figure 8. Non-Retriggerable Monostables Circuitry**

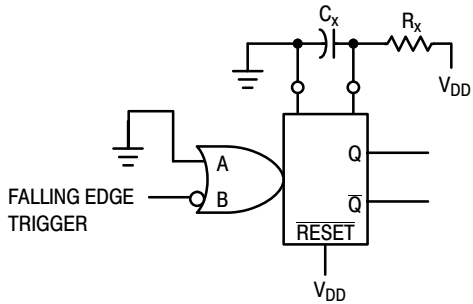

**Figure 9. Use of a Diode to Limit Power Down Current Surge**

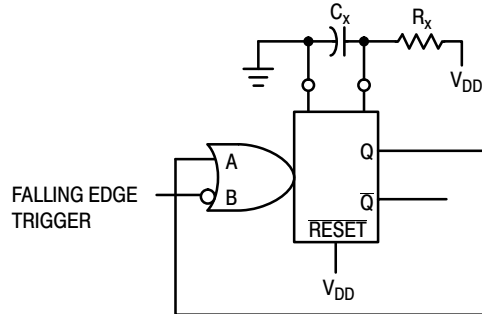

**Figure 10. Connection of Unused Sections**

# MECHANICAL CASE OUTLINE PACKAGE DIMENSIONS

ON Semiconductor®



SCALE 1:1

## SOIC-16 CASE 751B-05 ISSUE K

DATE 29 DEC 2006



**NOTES:**

1. DIMENSIONING AND TOLERANCING PER ANSI Y14.5M, 1982.
2. CONTROLLING DIMENSION: MILLIMETER.
3. DIMENSIONS A AND B DO NOT INCLUDE MOLD PROTRUSION.
4. MAXIMUM MOLD PROTRUSION 0.15 (0.006) PER SIDE.
5. DIMENSION D DOES NOT INCLUDE DAMBAR PROTRUSION. ALLOWABLE DAMBAR PROTRUSION SHALL BE 0.127 (0.005) TOTAL IN EXCESS OF THE D DIMENSION AT MAXIMUM MATERIAL CONDITION.

DIM	MILLIMETERS		INCHES	
	MIN	MAX	MIN	MAX
A	9.80	10.00	0.386	0.393
B	3.80	4.00	0.150	0.157
C	1.35	1.75	0.054	0.068
D	0.35	0.49	0.014	0.019
F	0.40	1.25	0.016	0.049
G	1.27 BSC		0.050 BSC	
J	0.19	0.25	0.008	0.009
K	0.10	0.25	0.004	0.009
M	0°	7°	0°	7°
P	5.80	6.20	0.229	0.244
R	0.25	0.50	0.010	0.019

- |  |  |  |  |
|--|--|--|--|
| <p><b>STYLE 1:</b></p> <p>PIN 1. COLLECTOR<br/>2. BASE<br/>3. EMITTER<br/>4. NO CONNECTION<br/>5. EMITTER<br/>6. BASE<br/>7. COLLECTOR<br/>8. COLLECTOR<br/>9. BASE<br/>10. EMITTER<br/>11. NO CONNECTION<br/>12. EMITTER<br/>13. BASE<br/>14. COLLECTOR<br/>15. EMITTER<br/>16. COLLECTOR</p>                           | <p><b>STYLE 2:</b></p> <p>PIN 1. CATHODE<br/>2. ANODE<br/>3. NO CONNECTION<br/>4. CATHODE<br/>5. CATHODE<br/>6. NO CONNECTION<br/>7. ANODE<br/>8. CATHODE<br/>9. CATHODE<br/>10. ANODE<br/>11. NO CONNECTION<br/>12. CATHODE<br/>13. CATHODE<br/>14. NO CONNECTION<br/>15. ANODE<br/>16. CATHODE</p> | <p><b>STYLE 3:</b></p> <p>PIN 1. COLLECTOR, DYE #1<br/>2. BASE, #1<br/>3. EMITTER, #1<br/>4. COLLECTOR, #1<br/>5. COLLECTOR, #2<br/>6. BASE, #2<br/>7. EMITTER, #2<br/>8. COLLECTOR, #2<br/>9. COLLECTOR, #3<br/>10. BASE, #3<br/>11. EMITTER, #3<br/>12. COLLECTOR, #3<br/>13. COLLECTOR, #4<br/>14. BASE, #4<br/>15. EMITTER, #4<br/>16. COLLECTOR, #4</p>   | <p><b>STYLE 4:</b></p> <p>PIN 1. COLLECTOR, DYE #1<br/>2. COLLECTOR, #1<br/>3. COLLECTOR, #2<br/>4. COLLECTOR, #2<br/>5. COLLECTOR, #3<br/>6. COLLECTOR, #3<br/>7. COLLECTOR, #4<br/>8. COLLECTOR, #4<br/>9. BASE, #4<br/>10. EMITTER, #4<br/>11. BASE, #3<br/>12. EMITTER, #3<br/>13. BASE, #2<br/>14. EMITTER, #2<br/>15. BASE, #1<br/>16. EMITTER, #1</p> |
| <p><b>STYLE 5:</b></p> <p>PIN 1. DRAIN, DYE #1<br/>2. DRAIN, #1<br/>3. DRAIN, #2<br/>4. DRAIN, #2<br/>5. DRAIN, #3<br/>6. DRAIN, #3<br/>7. DRAIN, #4<br/>8. DRAIN, #4<br/>9. GATE, #4<br/>10. SOURCE, #4<br/>11. GATE, #3<br/>12. SOURCE, #3<br/>13. GATE, #2<br/>14. SOURCE, #2<br/>15. GATE, #1<br/>16. SOURCE, #1</p> | <p><b>STYLE 6:</b></p> <p>PIN 1. CATHODE<br/>2. CATHODE<br/>3. CATHODE<br/>4. CATHODE<br/>5. CATHODE<br/>6. CATHODE<br/>7. CATHODE<br/>8. CATHODE<br/>9. ANODE<br/>10. ANODE<br/>11. ANODE<br/>12. ANODE<br/>13. ANODE<br/>14. ANODE<br/>15. ANODE<br/>16. ANODE</p>                                 | <p><b>STYLE 7:</b></p> <p>PIN 1. SOURCE N-CH<br/>2. COMMON DRAIN (OUTPUT)<br/>3. COMMON DRAIN (OUTPUT)<br/>4. GATE P-CH<br/>5. COMMON DRAIN (OUTPUT)<br/>6. COMMON DRAIN (OUTPUT)<br/>7. COMMON DRAIN (OUTPUT)<br/>8. SOURCE P-CH<br/>9. SOURCE P-CH<br/>10. COMMON DRAIN (OUTPUT)<br/>11. COMMON DRAIN (OUTPUT)<br/>12. COMMON DRAIN (OUTPUT)<br/>13. GATE N-CH<br/>14. COMMON DRAIN (OUTPUT)<br/>15. COMMON DRAIN (OUTPUT)<br/>16. SOURCE N-CH</p> |  |

### SOLDERING FOOTPRINT



DIMENSIONS: MILLIMETERS

<b>DOCUMENT NUMBER:</b>	<b>98ASB42566B</b>	Electronic versions are uncontrolled except when accessed directly from the Document Repository. Printed versions are uncontrolled except when stamped "CONTROLLED COPY" in red.
<b>DESCRIPTION:</b>	<b>SOIC-16</b>	<b>PAGE 1 OF 1</b>

ON Semiconductor and are trademarks of Semiconductor Components Industries, LLC dba ON Semiconductor or its subsidiaries in the United States and/or other countries. ON Semiconductor reserves the right to make changes without further notice to any products herein. ON Semiconductor makes no warranty, representation or guarantee regarding the suitability of its products for any particular purpose, nor does ON Semiconductor assume any liability arising out of the application or use of any product or circuit, and specifically disclaims any and all liability, including without limitation special, consequential or incidental damages. ON Semiconductor does not convey any license under its patent rights nor the rights of others.