

# One cylinder small engine control IC

Powered by SMARTMOS technology, the 33813 delivers a cost-optimized IC solution for managing one-cylinder engines. With five drivers, two pre-drivers, a 5.0 V regulator for the MCU, a protected external sensor supply and a high level of integration, the IC offers an ideal response to contemporary market requirements. The innovative VRS system optimizes noise immunity under cranking conditions. Diagnostic and protection features present on all outputs allow applications to operate with greater safety.

## Features:

- Operates over supply voltage range of  $4.5\text{ V} < V_{PWR} < 36\text{ V}$
- Start-up/shut-down control and power sequence logic with KEYSW input
- MCU supply:  $V_{CC}$  is a 5.0 V ( $\pm 2.0\%$ , 200 mA) regulated supply
- Sensor supply:  $V_{PROT}$  (100 mA) is a  $V_{CC}$  tracking protected sensor supply
- Two configurable pre-drivers for IGBT or general purpose gate MOSFETs for ignition and  $O_2$  sensor (HEGO) heater:
  - PWM
  - Overcurrent shutdown
  - Short-to-battery shutdown
- Five low-side drivers with full diagnostics, self-protection and PWM control:
  - One fuel injector drivers,  $R_{DS(on)} = 0.6\ \Omega$ ,  $I_{LIMIT} = 1.8\text{ A}$ , to drive typical  $12\ \Omega$  high-impedance injectors
  - Relay 1 driver,  $R_{DS(on)} = 0.4\ \Omega$ ,  $I_{LIMIT} = 3.0\text{ A}$ , to drive fuel pump
  - Relay 2 driver,  $R_{DS(on)} = 1.5\ \Omega$ ,  $I_{LIMIT} = 1.2\text{ A}$ , to drive power relay
  - Lamp driver,  $R_{DS(on)} = 1.5\ \Omega$ ,  $I_{LIMIT} = 1.2\text{ A}$ , to drive warning lamp or an LED
  - Programmable Tachometer Driver,  $R_{DS(on)} = 20\ \Omega$ ,  $I_{shutdown} = 60\text{ mA}$ , to drive a Tachometer display
- Innovative configurable VRS conditioning circuit, with two different parameter settings for engine cranking and running mode and an optional automatic mode to improve noise immunity in cranking conditions
- K-line (ISO9141)
- MCU reset generator and programmable watchdog
- MCU Interface: 16-bit SPI and parallel interface with 5.0 V IO capability

33813

ONE CYLINDER SMALL ENGINE  
CONTROL IC



98ASA00737D  
AE SUFFIX (PB-FREE)  
48-PIN LQFP-EP

## Applications:

Small engine control for:

- Motor scooters
- Small motorcycles
- Lawn mowers
- Lawn trimmers
- Snow blowers
- Chain saws
- Gasoline-driven electrical generators
- Outboard motors

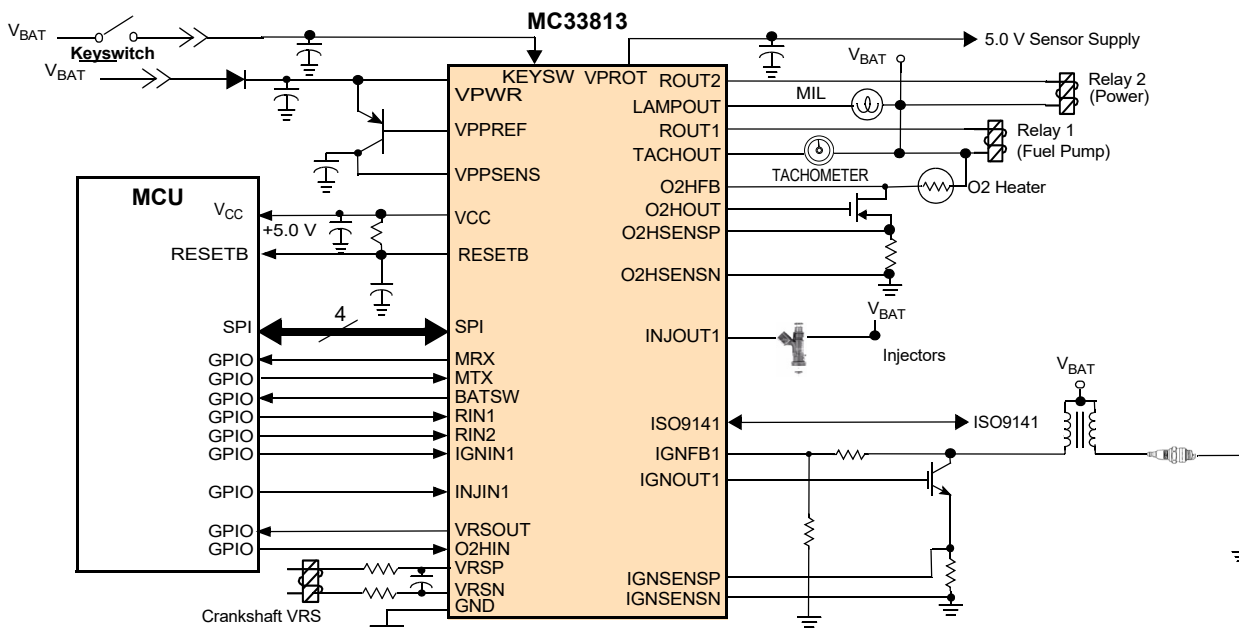

Figure 1. 33813 simplified application diagram

# Table of Contents

1	Orderable parts	3
2	Internal block diagram	4
3	Pin connections	5
3.1	Pinout diagram	5
3.2	Pin definitions	5
4	General product characteristics	8
4.1	Maximum ratings	8
4.2	Static electrical characteristics	10
4.3	Dynamic electrical characteristics	15
4.4	Timing diagrams	17
4.5	Typical electrical characteristics	18
5	General IC functional description and application information	21
5.1	System controller	21
5.2	Watchdog	26
5.3	System reset	29
5.4	Power supplies	30
5.5	Drivers blocks	34
5.6	Pre-driver	42
5.7	VRS circuitry	46
5.8	ISO9141 bus	53
5.9	Mode code and revision number	54
5.10	SPI	54
5.11	SPI registers mapping	57
6	Typical applications	64
6.1	Output OFF open load fault	64
6.2	Low voltage operation	64
6.3	Low-side injector driver voltage clamp	64
6.4	Reverse battery protection	64
7	Packaging	65
7.1	Package mechanical dimensions	65
8	Revision history	69

# 1 Orderable parts

Table 1. Orderable part variations

Part Number <sup>(1)</sup>	Temperature (T <sub>A</sub> )	Package
MC33813AE	-40 °C to 125 °C	48 LQFP-EP

Notes

1. To order parts in tape and reel, add the R2 suffix to the part number.

## 2 Internal block diagram

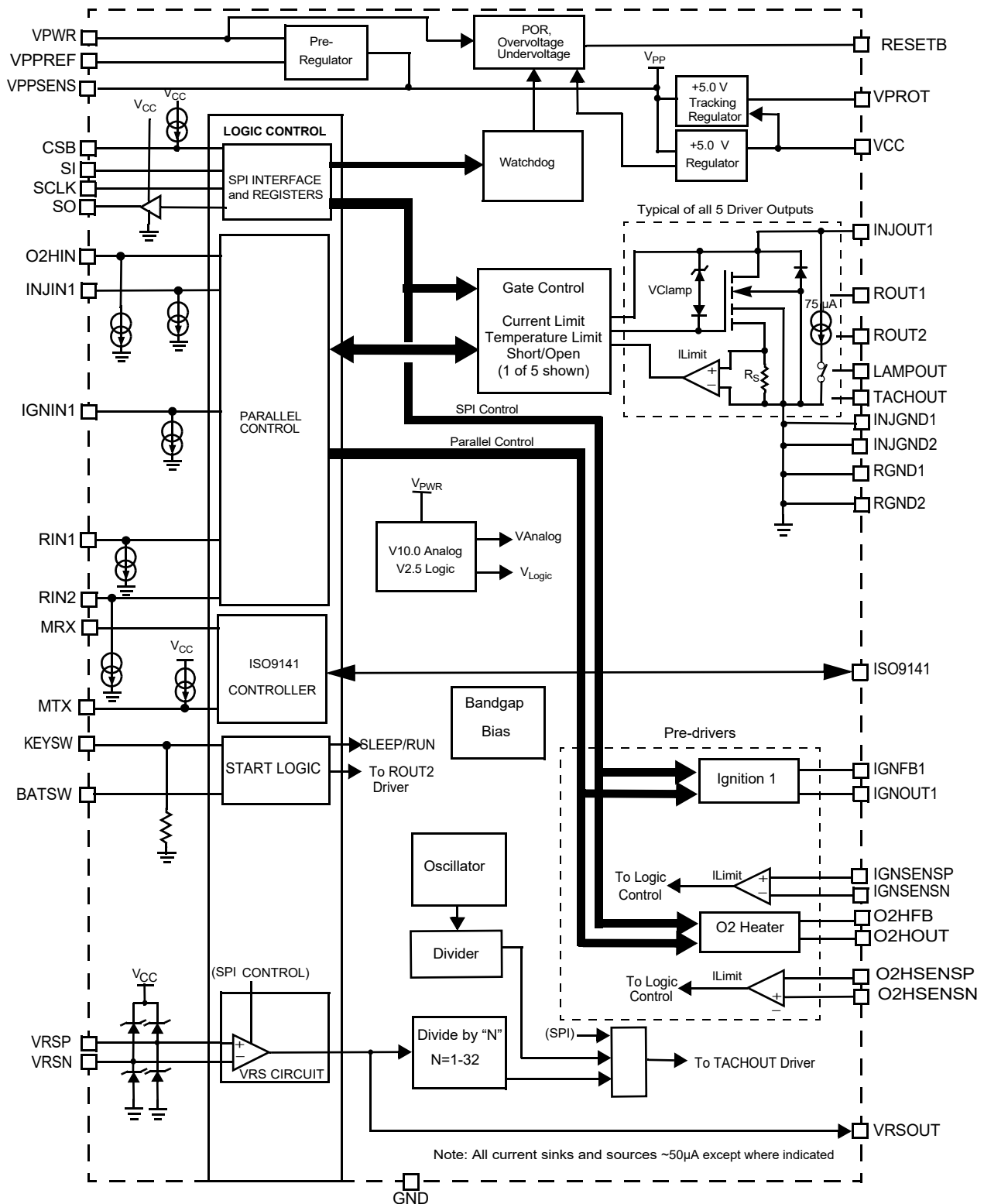

Figure 2. Simplified internal block diagram

## 3 Pin connections

### 3.1 Pinout diagram

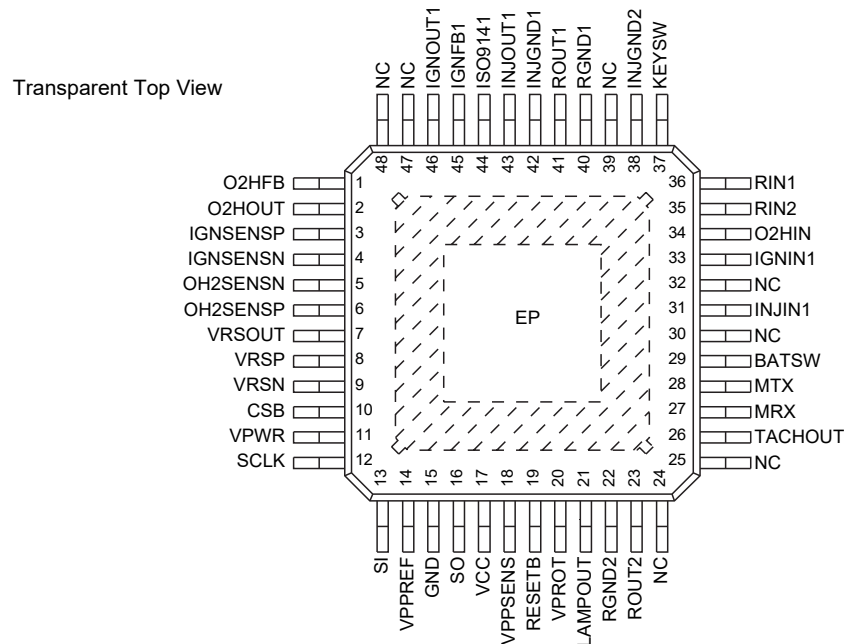

Figure 3. 33813 Pin connections

### 3.2 Pin definitions

Table 2. 33813 pin definitions

Pin	Pin Name	Pin Function	Formal Name	Description
1	O2HFB	Input	O2 Sensor Heater Feedback Input	Voltage feedback from drain of O2 Sensor Heater driver FET. If used as IGBT driver, voltage feedback from collector of IGBT through 10:1 voltage divider (9R:1R).
2	O2HOUT	Output	O2 Sensor Heater Output	Pre-driver output for O2 Sensor Heater driven by SPI input or O2HIN pin
3	IGNSENSP	Input	Ignition Current Sense Input Positive	Positive input to the ignition current sense differential amplifier. Measures current in IGBT emitter resistor (or MOSFET source resistor) for IGNOUT1 and IGNOUT2, if used
4	IGNSSENSN	Input	Ignition Current Sense Input Negative	Negative input to the ignition current sense differential amplifier. Measures current in IGBT emitter resistor (or MOSFET source resistor) for IGNOUT1 and IGNOUT2, if used
5	O2HSENSN	Input	O2 Heater Current Sense Input Negative	Negative input to the O2 heater current sense differential amplifier. Measures current in of O2 heater driver MOSFET source resistor (or IGBT emitter resistor), if used
6	O2HSENSP	Input	O2 Heater Current Sense Input Positive	Positive input to the O2 heater current sense differential amplifier. Measures current in of O2 heater driver MOSFET source resistor (or MOSFET source resistor) for IGNOUT1 and IGNOUT2, if used
7	VRSOUT	Output	VRS Conditioned Output	5.0 V Logic Level Output from conditioned VRS differential inputs VRSP, VRSN

**Table 2. 33813 pin definitions**

Pin	Pin Name	Pin Function	Formal Name	Description
8	VRSP	Input	Variable Reluctance Sensor Positive Input	The VRSP and VRSN form a differential input for the Variable Reluctance Sensor attached to the crankshaft toothed wheel.
9	VRSN	Input	Variable Reluctance Sensor Negative Input	The VRSP and VRSN form a differential input for the Variable Reluctance Sensor attached to the crankshaft toothed wheel.
10	CSB	Input	SPI Chip Select	The Chip Select input pin is an active low signal sent by the MCU to indicate that the device is being addressed.
11	VPWR	Supply Input	Main Voltage Supply Input	VPWR is the main voltage supply input for the device. Should be connected to a 12 Volt battery with reverse battery protection and adequate transient protection.
12	SCLK	Input	SPI Clock Input	The SCLK input pin is used to clock in and out the serial data on the SI and SO pins while being addressed by the CSB.
13	SI	Input	SPI Data Input	The SI input pin is used to receive serial data into the device from the MCU.
14	VPPREF	Output	VPP Reference Base Drive	Base drive for external PNP pass transistor
15	GND	Ground	Ground	Ground pin, return for all voltage supplies
16	SO	Output	SPI Data Output	The SO output pin is used to transmit serial data from the device to the MCU.
17	VCC	Supply	VCC Supply Protected Output	5.0 Volt supply output for MCU V <sub>CC</sub> . This output supplies the V <sub>CC</sub> voltage for 5.0 Volt MCUs. It is short-circuit and overcurrent protected.
18	VPPSENS	Input	Voltage Sense from VPP	Feedback to internal V <sub>PP</sub> 6.5 Volt regulator from external pass transistor
19	RESETB	Output	RESETB Output to MCU	5.0 V Logic level reset signal used to reset the MCU during under and overvoltage conditions and for initial power-up, down and watchdog timeouts
20	VPROT	Output	Sensor Supply Protected Output	The VPROT Output is a protected 5.0 Volt output that tracks the V <sub>CC</sub> voltage but isolates the VCC output against shorts to ground and to battery. It is intended to supply sensors which are located off of the ECU board.
21	LAMP0UT	Output	Warning Lamp Output	Low-side driver output for MIL (warning lamp) driven by SPI input command
22	RGND2	Ground	ROUT2 Power Ground	Ground connection for ROUT 2 low-side driver. Must be tied to VPWR Ground.
23	ROUT2	Output	Relay Driver 2 Output	Low-side relay driver output # 2 driven by SPI input command or RIN2 logic input
24, 25, 30, 32, 39, 47, 48	N.C.	No Connect	Unused pin	
26	TACHOUT	Output	Tachometer output	This pin provides the low-side drive for a tachometer gauge or alternatively as a SPI controlled low-side driver, or oscillator output.
27	MRX	Output	Low-side Driver Output	Output 5.0 V logic level ISO9141 data to the MCU from the ISO9141 IN/OUT pin
28	MTX	Input	ISO9141 MCU Data Input	Input 5.0 V logic level ISO9141 data from the MCU to the ISO9141 IN/OUT pin
29	BATSW	Output	Battery Switch	This output is a 5.0 V logic level that is high when KEYSW is high. It is only low when KEYSW is low. It can also be controlled via the SPI.
31	INJIN1	Input	Injector Driver Input 1	5.0 V logic level input from the MCU to control the injector 1 driver output. (Can also be controlled via the SPI)
33	IGNIN1	Input	Ignition Input 1	5.0 V logic level input from MCU controlling the ignition coil # 1 current flow and spark. (Can also be controlled via the SPI)
34	O2HIN	Input	O2 Sensor Heater Input	5.0 V logic level input used to turn on and off the O2HOUT driver. The O2HOUT driver can also be turned on and off via the SPI if this pin is not present in a different package.
35	RIN2	Input	Relay Driver Input 2	5.0 V logic level input from the MCU to control the relay 2 driver output ROUT2. The ROUT2 driver can also be turned on and off via the SPI if this pin is not present in a different package.
36	RIN1	Input	Relay Driver Input 1	5.0 V logic level input from the MCU to control the relay 1 driver output ROUT1. The ROUT1 driver can also be turned on and off via the SPI if this pin is not present in a different package.

**Table 2. 33813 pin definitions**

Pin	Pin Name	Pin Function	Formal Name	Description
37	KEYSW	Input	Key Switch Input	The Key Switch Input is a $V_{PWR}$ level signal that indicates that the Key is inserted and turned to the ON/OFF position. In the ON position the (KEYSW = $V_{BAT}$ ) the IC is enabled and BATSW = HIGH (Relay 2 ON if programmed in the SPI). In the OFF position the IC is in Sleep mode, only when the PWREN bit in the SPI register is also low.
38	INJGND2	Ground	Injector Driver 2 Ground	Ground connection for injector 2 low-side driver. Must be tied to VPWR ground
40	RGND1	Ground	ROUT1 Power Ground	Ground connection for ROUT 1 low-side driver. Must be tied to VPWR ground
41	ROUT1	Output	Relay Driver 1 Output	Low-side relay driver output # 1 driven by the SPI input command or RIN1 logic input
42	INJGND1	Ground	Injector Driver 1 Ground	Ground connection for injector 1 low-side driver. Must be tied to VPWR ground
43	INJOUT1	Output	Injector Driver 1 Output	Low-side driver output for injector 1 driven by the SPI input or by parallel input INJIN1
44	ISO9141	Input/Output	ISO9141 K-Line Bidirectional Serial Data Signal	ISO9141 pin is $V_{PWR}$ level IN/OUT signal which is connected to an external ECU tester that uses the ISO9141 protocol. The output is open drain with an internal 32 k $\Omega$ pull-up resistor, and the Input is a ratiometric $V_{PWR}$ level threshold comparator.
45	IGNFB1	Input	Feedback from Collector 1	Voltage feedback from collector of ignition # 1 driver IGBT through 10:1 voltage divider (9R:1R)(or voltage feedback from the drain of the FET connected to IGNOUT1, if selected)
46	IGNOUT1	Output	Ignition Output 1	Output to gate of IGBT or GPGD for ignition # 1

# 4 General product characteristics

## 4.1 Maximum ratings

**Table 3. Maximum ratings**

All voltages are with respect to ground, unless mentioned otherwise. Exceeding these ratings may cause malfunction or permanent device damage.

Symbol	Parameter	Min.	Max.	Unit	Notes
<b>ELECTRICAL RATINGS</b>					
$V_{PWR}$	$V_{PWR}$ Supply Voltage	-0.3	45	$V_{DC}$	
$V_{PP\_Ext}$	$V_{PP}$ Supply Voltage (If supplied externally and not using internal VPP regulator) • $V_{PP\_REF}$ • $V_{PP\_SENSE}$	-0.3 -0.3	45 10	$V_{DC}$	
$V_{CC}$	$V_{CC}$ Regulator	-0.3	7.0	$V_{DC}$	
$V_{PROT}$	$V_{PROT}$ Regulator	-0.3	$V_{PWR}$	$V_{DC}$	
$V_{IL}, V_{IH}$	SPI Interface and Logic Input Voltage ( $V_{SI}, V_{SCLK}, V_{CSB}, V_{RIN1}, V_{RIN2}, V_{INJIN1}, V_{IGNIN1}, V_{O2HIN}, V_{MTX}$ )	-0.3	$V_{CC}$	$V_{DC}$	
$V_{IL}, V_{IH}$	SPI Interface and Logic Output Voltage ( $V_{SO}, V_{BATSW}, V_{MRX}, V_{VRSOUT}$ )	-0.3	$V_{CC}$	$V_{DC}$	
$V_{OUTX}$	All Low-side Drivers Drain Voltage ( $V_{INJOUT1}, V_{ROUT1}, V_{ROUT2}, V_{LAMP\_OUT}, V_{TACHOUT}$ )	-0.3	$V_{CLAMP}$	$V_{DC}$	
$V_{GDX}$	All Pre-drivers Output Voltage ( $V_{IGNOUT1}, V_{O2HOUT}$ )	-0.3	10	$V_{DC}$	
$V_{GDFB}$	All Pre-driver Feedback Inputs Voltage ( $V_{IGNFB1}, V_{IGNFB2}, V_{O2HFB}$ )	-1.5	60	$V_{DC}$	
$V_{ISENS}$	All Pre-driver Current Sense Inputs Voltage ( $V_{IGNSENSN}, V_{IGNSENSP}, V_{O2HSENSN}, V_{O2HSENSP}$ )	-0.3	1.0	$V_{DC}$	
$V_{KEYSW}$	KEYSW Input Voltage ( $V_{KEYSW}$ )	-18	$V_{PWR}$	$V_{DC}$	
$V_{RESETB}$	RESETB Output Voltage ( $V_{RESETB}$ )	-0.3	$V_{CC}$	$V_{DC}$	
$V_{ISO9141}$	ISO9141 Input/Output Voltage ( $V_{ISO9141}$ )	-18	$V_{PWR}$	$V_{DC}$	
$V_{VRS\_IN}$	Maximum Voltage for VRSN and VRSP inputs to ground	-0.5	6.0	$V_{DC}$	
$I_{VRSX\_IN}$	Maximum Current for VRSN and VRSP inputs (internal diodes limit voltage)	-	15	mA	
$E_{CLAMP}$	Output Clamp Energy (INJOUT1, ROUT1, ROUT2) • $T_{JUNCTION} = 150\text{ }^{\circ}\text{C}, I_{OUT} = 1.0\text{ A}$	-	100	mJ	
$E_{CLAMP\_LAMP}$	Output Clamp Energy (LAMP\_OUT) • $T_{JUNCTION} = 150\text{ }^{\circ}\text{C}, I_{OUT} = 0.5\text{ A}$	-	35	mJ	
$V_{ESD1}$ $V_{ESD2}$ $V_{ESD3}$	ESD Voltage • Human Body Model (HBM) • Charge Device Model (CDM) (corner pins) • Charge Device Model (CDM)	- - -	$\pm 2000$ $\pm 750$ $\pm 500$	V	(2)

Notes

- ESD testing is performed in accordance with the Human Body Model (HBM) ( $C_{ZAP} = 100\text{ pF}, R_{ZAP} = 1500\text{ }\Omega$ ) and the Charge Device Model.



**Table 3. Maximum ratings**

All voltages are with respect to ground, unless mentioned otherwise. Exceeding these ratings may cause malfunction or permanent device damage.

Symbol	Parameter	Min.	Max.	Unit	Notes
<b>THERMAL RATINGS</b>					
$T_A$ $T_J$ $T_C$	Operating Temperature (Automotive grade version) <ul style="list-style-type: none"> <li>• Ambient</li> <li>• Junction</li> <li>• Case</li> </ul>	-40 -40 -40	125 150 125	°C	
$T_{STG}$	Storage Temperature	-55	150	°C	
$T_{PPRT}$	Peak Package Reflow Temperature During Reflow	-	Note 4	°C	(3), (4)

Thermal Resistance and Package Dissipation Ratings

$R_{\theta JA}$ $R_{\theta JC}$	Thermal Resistance <ul style="list-style-type: none"> <li>• Junction-to-Ambient (LQFP-48-EP Package) (Single Layer Board)</li> <li>• Junction-to-Case (LQFP-48-EP Package)</li> </ul>	29 2.4	29 2.4	°C/W	
------------------------------------	---	-----------	-----------	------	--

Notes

- Pin soldering temperature limit is for 10 seconds maximum duration. Not designed for immersion soldering. Exceeding these limits may cause malfunction or permanent damage to the device.
- NXP's Package Reflow capability meets Pb-free requirements for JEDEC standard J-STD-020C. For Peak Package Reflow Temperature and Moisture Sensitivity Levels (MSL), go to [www.nxp.com](http://www.nxp.com), search by part number, remove prefixes/suffixes, and enter the core ID to view all orderable parts (for MC33xxxD enter 33xxx) and review parametrics.

## 4.2 Static electrical characteristics

**Table 4. Power input static electrical characteristics**

Characteristics noted under conditions of  $6.0\text{ V} \leq V_{PWR} \leq 18\text{ V}$ ,  $-40\text{ }^\circ\text{C} \leq T_{CASE} \leq 125\text{ }^\circ\text{C}$  and Calibrated Timers, unless otherwise noted. Where applicable, typical values reflect the parameter's approximate average value with  $V_{PWR} = 14\text{ V}$ ,  $T_A = 25\text{ }^\circ\text{C}$ .

Symbol	Characteristic	Min.	Typ.	Max.	Unit	Notes
<b>POWER INPUT (VPWR)</b>						
$V_{PWR(LS)}$ $V_{PWR(FO)}$ $V_{PWR(FP)}$	Supply Voltage (measured at VPWR pin) • Logic Stable Range • Full Operational Range • Full Parameter Specification Range	2.5 4.5 6.0	- - -	45 36 18	V	(5)
$I_{VPWR(ON)}$	Supply Current • All Outputs Disabled (Normal mode), excludes base current to the external pnp	-	10.0	14.0	mA	
$I_{VPWR(SS)}$	Sleep State Supply Current (Must have PWREN = 0 and KEYSW $\leq$ 0.8 V for sleep state), • $V_{PWR} = 18\text{ V}$	-	10	20	$\mu$ A	
$V_{PWR(OV)}$	$V_{PWR}$ Overvoltage Shutdown Threshold Voltage (OV Reset)	37.5	39	42	V	(6)
$V_{PWR(OV-HYS)}$	$V_{PWR}$ Overvoltage Shutdown Hysteresis Voltage	0.5	1.5	3.0	V	
$V_{CC(POR)}$	$V_{CC}$ Power On Reset Voltage Threshold (POR), (rising voltage)	3.9	-	4.9	V	
$V_{CC(UV)}$	$V_{CC}$ Undervoltage Shutdown Threshold Voltage (UV Reset), (falling voltage)	2.9	-	3.9	V	(7)
$V_{CC(UV/POR-HYS)}$	$V_{CC}$ POR and Undervoltage Shutdown Hysteresis Voltage	100	-	-	mV	
$V_{CC,NOVERLAP}$	$V_{CC}$ POR and Undervoltage Non-overlap (POR-UV)	0.8	1.0	1.2	V	
<b>VOLTAGE PRE-REGULATOR OUTPUT (VPPREF, VPPSENS)</b>						
$V_{PPSENS}$	VPPSENS Output Voltage	5.85	6.5	7.15	V	(8)
$I_{VPPREF\_CL}$	VPPREF Current Limit	-5.0	-15	-20	mA	
$V_{OCE}$	Output Capacitance External (ceramic)	2.2	-	25	$\mu$ F	
$I_{VPPSENS}$	VPPSENS Quiescent Current (excluding external PNP current)	-	-	3	mA	
REGLINE_VPP	Line Regulation $I_{VCC} = 100\text{ mA}$ , $I_{VPROT} = 50\text{ mA}$ , $9.0\text{ V} < V_{PWR} < 18\text{ V}$ and Diodes Inc. FZT753TA PNP	-	2.0	25	mV	
$V_{DROPOUT\_VPP}$	Dropout Voltage (Minimal Input/Output Voltage, tracks input below) $I_{VCC} = 100\text{ mA}$ , $I_{VPROT} = 50\text{ mA}$ and Diodes Inc. FZT753TA PNP	-	-	500	mV	
<b>VOLTAGE REGULATOR OUTPUTS (VCC, VPROT)</b>						
$V_{CC}$	$V_{CC}$ Output Voltage $0 \leq I_{VCC} \leq I_{VCC\_C}$	4.9	5.0	5.1	V	
$I_{VCC\_C}$	$V_{CC}$ Output Current Continuous	-	-	200	mA	
$I_{VCC-VPROT}$	$V_{PROT}$ Output Voltage (tracks VCC) $I_{VCC} = 100\text{ mA}$ , $I_{VPROT} = 50\text{ mA}$ $9.0\text{ V} < V_{PWR} < 18\text{ V}$	-	-	25	mV	
$I_{VPROT\_C}$	$V_{PROT}$ Output Current Continuous	-	-	100	mA	
$I_{VCC\_CL}$	$V_{CC}$ Output Current Limiting	200	-	500	mA	(8)
$I_{VPROT\_CL}$	$V_{PROT}$ Output Current Limiting	110	-	260	mA	
$V_{OCE}$	Output Capacitance External ( $V_{CC}$ and $V_{PROT}$ ) without reverse protection diode	2.2	-	47	$\mu$ F	

**Notes**

5. This parameter is guaranteed by design but is not production tested.
6. Overvoltage thresholds minimum and maximum include hysteresis.
7. Undervoltage thresholds minimum and maximum include hysteresis
8. Guaranteed at  $9.0\text{ V} \leq V_{PWR} \leq 18\text{ V}$

**Table 4. Power input static electrical characteristics**

Characteristics noted under conditions of  $6.0\text{ V} \leq V_{PWR} \leq 18\text{ V}$ ,  $-40\text{ }^\circ\text{C} \leq T_{CASE} \leq 125\text{ }^\circ\text{C}$  and Calibrated Timers, unless otherwise noted. Where applicable, typical values reflect the parameter's approximate average value with  $V_{PWR} = 14\text{ V}$ ,  $T_A = 25\text{ }^\circ\text{C}$ .

Symbol	Characteristic	Min.	Typ.	Max.	Unit	Notes
<b>VOLTAGE REGULATOR OUTPUTS (VCC, VPROT) (CONTINUED)</b>						
V <sub>CC</sub>	VCC Output Voltage $0 \leq I_{VCC} \leq I_{VCC\_C}$	4.9	5.0	5.1	V	
REG <sub>LINE_VB</sub>	Line Regulation (Both V <sub>CC</sub> and V <sub>PROT</sub> ) $I_{VCC} = 100\text{ mA}$ , $I_{PROT} = 50\text{ mA}$ , $9.0\text{ V} < V_{PWR} < 18\text{ V}$	-	2.0	25	mV	
REG <sub>LOAD_VB</sub>	Load Regulation (Both V <sub>CC</sub> and V <sub>PROT</sub> ) measured from 10% - 90% of I <sub>VCC_C</sub> and I <sub>PROT_C</sub> , $V_{PWR} = 13\text{ V}$	-	20	35	mV	
V <sub>DROPOUT_VCC/VPROT</sub>	Droput Voltage (Both V <sub>CC</sub> and V <sub>PROT</sub> ) (Minimal Input/Output Voltage $I_{VCC} = 100\text{ mA}$ , $I_{VPROT} = 50\text{ mA}$ , tracks input below)	-	-	500	mV	

**ALL LOW-SIDE DRIVERS (INJOUT1, ROUT1, ROUT2, LAMPOUT, TACHOUT)**

V <sub>OUT(FLT-TH)</sub>	Output Fault Detection Voltage Threshold, Outputs programmed OFF (Open Load), Outputs programmed ON (Short to Battery)	2.0	2.5	3.0	V	(9)
I <sub>(OFF)OCO</sub>	Output OFF Open Load Detection Current (INJ1, RELAY1, RELAY2 AND LAMP) • V <sub>DRAIN</sub> = 18 V, Outputs Programmed OFF	40	75	115	μA	
I <sub>(OFF)TACH</sub>	Output OFF Open Load Detection Current TachOut	10	-	30	μA	
I <sub>OUT(LKG)</sub>	Output Leakage Current • V <sub>DRAIN</sub> = 24 V, Open Load Detection Disabled and Output commanded OFF	-	-	20	μA	
T <sub>LIM</sub>	Overtemperature Shutdown (OT)	155	-	185	°C	(9)
T <sub>LIM(HYS)</sub>	Overtemperature Shutdown Hysteresis	5.0	10	15	°C	(9)
V <sub>OC</sub>	Output Clamp Voltage • I <sub>D</sub> = 20 mA	48	53	60	V	

**INJOUT1**

R <sub>DS(ON)_INJx</sub>	Drain-to-Source ON Resistance • I <sub>OUT</sub> = 1.0 A, T <sub>J</sub> = 150 °C, V <sub>PWR</sub> = 13 V	-	-	0.6	Ω	
I <sub>OUT(LIM)_INJx</sub>	Output Self Limiting Current	1.8	-	3.0	A	

**ROUT1**

R <sub>DS(ON)_R1</sub>	Driver Drain-to-Source ON Resistance • I <sub>OUT</sub> = 700 mA, T <sub>J</sub> = 150 °C, V <sub>PWR</sub> = 13 V	-	-	0.4	Ω	
I <sub>OUT(LIM)_R1</sub>	Output Self-limiting Current (Has inrush current timer)	3.0	-	6.0	A	

**ROUT2**

R <sub>DS(ON)_R2</sub>	Driver Drain-to-Source ON Resistance • I <sub>OUT</sub> = 350 mA, T <sub>J</sub> = 150 °C, V <sub>PWR</sub> = 13 V	-	-	1.5	Ω	
I <sub>OUT(LIM)_R2</sub>	Output Self-limiting Current	1.2	-	2.4	A	

**LAMPOUT**

R <sub>DS(ON)_LAMP</sub>	Driver Drain-to-Source ON Resistance • I <sub>OUT</sub> = 1.0 A, T <sub>J</sub> = 150 °C, V <sub>PWR</sub> = 13 V	-	-	1.5	Ω	
I <sub>OUT(LIM)_LAMP</sub>	Output Self-limiting Current (Has inrush current timer)	1.2	-	2.4	A	

## Notes

9. This parameter is guaranteed by design, however it is not production tested.

**Table 4. Power input static electrical characteristics**

Characteristics noted under conditions of  $6.0\text{ V} \leq V_{PWR} \leq 18\text{ V}$ ,  $-40\text{ }^\circ\text{C} \leq T_{CASE} \leq 125\text{ }^\circ\text{C}$  and Calibrated Timers, unless otherwise noted. Where applicable, typical values reflect the parameter's approximate average value with  $V_{PWR} = 14\text{ V}$ ,  $T_A = 25\text{ }^\circ\text{C}$ .

Symbol	Characteristic	Min.	Typ.	Max.	Unit	Notes
<b>TACHOUT</b>						
$R_{DS(ON)_TACH}$	Driver Drain-to-Source ON Resistance • $I_{OUT} = 50\text{ mA}$ , $T_J = 150\text{ }^\circ\text{C}$ , $V_{PWR} = 13\text{ V}$	-	-	20	$\Omega$	
$I_{OUT(SHUTDOWN)_TACH}$	Output Current Shutdown	60	-	110	mA	

**ALL PRE-DRIVERS (IGNOUT1 AND O2HOUT)**

$V_{GS(ON)}$ $V_{GS(OFF)}$	Pre-driver Output Voltage, $V_{PWR} = 13\text{ V}$ • $I_{GD} = 500\text{ }\mu\text{A}$ • $I_{GD} = -500\text{ }\mu\text{A}$	7.0 0.0	8.0 0.375	9.0 0.5	V	
$I_{IGN\_GD\_H}$	IGNOUT1 Output Source Current (IGNOUT1 by default) • $1.0 \leq V_{GD} \leq 3.0$ , $V_{PWR} = 13\text{ V}$	10	-	-	mA	
$I_{(OFF)OCO}$	Output OFF Open Load Detection Current • $V_{DRAIN} = 18\text{ V}$ , Outputs Programmed OFF	40	75	115	$\mu\text{A}$	
$I_{GPGD\_GD\_H}$	GPGD Output Source Current (O2HOUT by default) at $1.0 \leq V_{GD} \leq 3.0$ , $V_{PWR} = 13\text{ V}$	10	-	-	mA	
$V_{IGNFB(FLT\_TH)}$ $V_{GPGD(FLT\_TH)}$	Pre-driver Fault Detection Voltage Threshold, Outputs programmed OFF (open load), Outputs programmed ON (short to battery) • $I_{GD} = 500\text{ }\mu\text{A}$ • $I_{GD} = -500\text{ }\mu\text{A}$	100 1.0	250 2.5	400 4.0	mV V	
$V_{CLAMP}$	Output Clamp Voltage	48	53	60	V	
$V_{SENS-TH}$	Overcurrent Voltage Threshold for O2HOUT • $V_{O2HSENSN}$ to $V_{O2HSENSP}$	180	200	220	mV	
$V_{SENS-TH}$	Overcurrent Voltage Threshold for IGNOUT1 • $V_{IGNSENSN}$ to $V_{IGNSENSP}$ (IGNIN1 = 1)	180	200	220	mV	
$I_{SENS-OFFSET}$	Current Sense Input Offset Current (IGNSENSP,IGNSENSN, O2HSENSN, O2HSENSP)	-	-	15	$\mu\text{A}$	
$I_{SENS-BIAS}$	Current Sense Input Bias Current	-	-	15	$\mu\text{A}$	

**ISO-9141 TRANSCEIVER PARAMETERS (8.0 V <  $V_{PWR}$  < 18 V)**

$V_{IL\_ISO}$	Input Low Voltage at ISO I/O pin	-	-	$0.3 \times V_{PWR}$	V	
$V_{IH\_ISO}$	Input High Voltage at ISO I/O pin	$0.7 \times V_{PWR}$	-	-	V	
$V_{HYST\_ISO}$	Input Hysteresis at ISO I/O pin	$0.15 \times V_{PWR}$	-	-	V	
$V_{OL\_ISO}$	Output Low-voltage at ISO I/O pin	-	-	$0.2 \times V_{PWR}$	V	
$V_{OH\_ISO}$	Output High-voltage at ISO I/O pin	$0.8 \times V_{PWR}$	-	-	V	
$I_{LIM\_ISO}$	Output current limit at ISO I/O pin (MTX = 0)	50	100	150	mA	
$C_{L\_ISO}$	Load capacitance at ISO I/O pin	0.01	3.0	10	nF	(10)
$I_{\_ISO}$	Output load current at ISO I/O pin (MTX = 0, RLOAD = 1.0 k $\Omega$ , $\pm 10\%$ )	-	12	-	mA	
$T_{LIM}$	Overtemperature Shutdown (OT)	155	-	185	$^\circ\text{C}$	(10)
$T_{LIM(HYS)}$	Overtemperature Shutdown Hysteresis	5.0	10	15	$^\circ\text{C}$	(10)

**Notes**

10. This parameter is guaranteed by design, however it is not production tested.

**Table 4. Power input static electrical characteristics**

Characteristics noted under conditions of  $6.0\text{ V} \leq V_{\text{PWR}} \leq 18\text{ V}$ ,  $-40\text{ }^\circ\text{C} \leq T_{\text{CASE}} \leq 125\text{ }^\circ\text{C}$  and Calibrated Timers, unless otherwise noted. Where applicable, typical values reflect the parameter's approximate average value with  $V_{\text{PWR}} = 14\text{ V}$ ,  $T_{\text{A}} = 25\text{ }^\circ\text{C}$ .

Symbol	Characteristic	Min.	Typ.	Max.	Unit	Notes
<b>VRS CONDITIONER INPUT</b>						
$V_{\text{VRS\_THRESH}}$	Comparator Thresholds	-	See Table variable via SPI or dynamically		mV	
$\text{Accu}_{\text{THRESH}}$	Threshold Accuracy Steady State Condition ( $\pm 20\%$ only valid for VRS DAC thresholds 110 mV and higher. All other thresholds guaranteed monotonic only.)	-	-	$\pm 20$	%	
$I_{\text{BIASRSX}}$	Input Bias Current VRSP and VRSN (2.5 V common mode must be off)	-5.0		5.0	$\mu\text{A}$	
$V_{\text{CLAMP\_P}}$	VRS Positive Clamp Voltage at $I_{\text{CLAMP}} = 10\text{ mA}$	5.5	-	5.8	V	
$V_{\text{CLAMP\_N}}$	VRS Negative Clamp Voltage at $I_{\text{CLAMP}} = 10\text{ mA}$	-0.45	-	-0.22	V	
<b>DIGITAL INTERFACE (MRX, MTX, CSB, SI, SCLK, SO, RINX, O2HIN, INJIN1, IGNIN1, BATSW, VRSOUT, RESETB)</b>						
$V_{\text{IH}}$	Input Logic High-voltage Thresholds	$0.7 \times V_{\text{CC}}$	-	$V_{\text{CC}} + 0.3$	V	
$V_{\text{IL}}$	Input Logic Low-voltage Thresholds	$\text{GND} - 0.3$	-	$0.2 \times V_{\text{CC}}$	V	
$V_{\text{HYS}}$	Input Logic Voltage Hysteresis	500	-	-	mV	
$C_{\text{IN}}$	Input Logic Capacitance	-	-	20	pF	
$I_{\text{LOGIC\_SS}}$	Sleep Mode Input Logic Current • KEYSW = 0 V	-10	-	10	$\mu\text{A}$	(11)
$I_{\text{LOGIC\_PD}}$	Input Logic Pull-down Current INJIN1, RIN1, RIN2, SI, SCLK, IGNIN1, O2HIN • 0.8 V to 5.0 V	30	50	100	$\mu\text{A}$	(11)
$I_{\text{TRISO}}$	SO Tri-state Output (in Tri-state mode, CSB = 1) • 0 V to 5.0 V	-10	-	10	$\mu\text{A}$	
$I_{\text{CSB}}$	CSB Input Current • CSB = $V_{\text{CC}}$	-10	-	10	$\mu\text{A}$	
$I_{\text{LOGIC\_PU}}$	Input Logic Pull-up Current - CSB and MTX • 0.0 to 4.2 V	-20	-40	-90	$\mu\text{A}$	
$I_{\text{CSB(LKG)}}$	CSB Leakage Current to $V_{\text{CC}}$ • CSB = 5.0 V, KEYSW = 0.0 V	-	-	10	$\mu\text{A}$	
$V_{\text{SO\_HIGH}}$ $V_{\text{MRX\_HIGH}}$	SO, MRX High-state Output Voltage (CSB = 0 for SO) • $I_{\text{SO-HIGH}} = -1.0\text{ mA}$	$V_{\text{CC}} - 0.4$	-	-	V	
$V_{\text{SO\_LOW}}$ $V_{\text{MRX\_LOW}}$	SO, MRX Low-state Output Voltage (CSB = 0 for SO) • $I_{\text{SO-LOW}} = 1.0\text{ mA}$	-	-	0.4	V	
$V_{\text{BATSW\_HIGH}}$	BATSW High-state Output Voltage • $I_{\text{SO-HIGH}} = -10\text{ mA}$	$V_{\text{CC}} - 1.0$	-	-	V	
$V_{\text{BATSW\_LOW}}$	BATSW Low-state Output Voltage • $I_{\text{SO-LOW}} = 10\text{ mA}$	-	-	1.0	V	
$V_{\text{KEYSW\_HIGH}}$	KEYSW High-state Input Voltage	4.5	-	$V_{\text{PWR}}$	V	
$V_{\text{KEYSW\_LOW}}$	KEYSW Low-state Input Voltage	-0.3	-	2.5	V	
$V_{\text{KEYSW\_HYS}}$	KEYSW Hysteresis	100	-	-	mV	

**Notes**

11. This parameter is guaranteed by design, however it is not production tested.

**Table 4. Power input static electrical characteristics**

Characteristics noted under conditions of  $6.0\text{ V} \leq V_{PWR} \leq 18\text{ V}$ ,  $-40\text{ }^\circ\text{C} \leq T_{CASE} \leq 125\text{ }^\circ\text{C}$  and Calibrated Timers, unless otherwise noted. Where applicable, typical values reflect the parameter's approximate average value with  $V_{PWR} = 14\text{ V}$ ,  $T_A = 25\text{ }^\circ\text{C}$ .

Symbol	Characteristic	Min.	Typ.	Max.	Unit	Notes
<b>DIGITAL INTERFACE (MRX, MTX,CSB, SI, SCLK, SO, RINX,O2HIN, INJIN1, IGNIN1, BATSW, VRSOUT, RESETB) (CONTINUED)</b>						
$V_{VRSOUT\_LOW}$	VRS Low-state Output Voltage • $I_{VRS-LOW} = 1.0\text{ mA}$	-	-	0.4	V	
$V_{VRSOUT\_HIGH}$	VRS High-state Output Voltage • $I_{VRS-HIGH} = 1.0\text{ mA}$	$V_{CC} - 0.4$	-	5.0	V	
$V_{RESET\_LOW}$	RESET Low-state Output Voltage • $I_{RESET-LOW} = 1.0\text{ mA}$	-	-	0.4	V	
$I_{RESET\_LEAKAGE\_HIGH}$	RESET High-state Leakage Current	-	-	25	$\mu\text{A}$	
$R_{RESET\_PULDOWN}$	RESET Pull-down Resistor	200	-	500	$\text{k}\Omega$	

## 4.3 Dynamic electrical characteristics

**Table 5. Dynamic electrical characteristics** (13)

Characteristics noted under conditions of  $6.0\text{ V} \leq V_{\text{PWR}} \leq 18\text{ V}$ ,  $-40\text{ }^\circ\text{C} \leq T_{\text{CASE}} \leq 125\text{ }^\circ\text{C}$  and Calibrated Timers, unless otherwise noted. Where applicable, typical values reflect the parameter's approximate average value with  $V_{\text{PWR}} = 14\text{ V}$ ,  $T_{\text{A}} = 25\text{ }^\circ\text{C}$ .

Symbol	Characteristic	Min	Typ	Max	Unit	Notes
<b>POWER INPUT</b>						
$t_{\text{RESET}}$	Required Low State Duration on $V_{\text{CC}}$ for Power On Reset • $V_{\text{CC}} \leq 0.2\text{ V}$	1.0	-	-	$\mu\text{s}$	
$t_{\text{(POR)}}$	Power on RESET pulse width	100	-	-	$\mu\text{s}$	
$t_{\text{(KEYSW\_FILTER)}}$	KEYSW Filter Time	-	12.7	-	ms	(12)
<b>WATCHDOG TIMER</b>						
WDMAX	Maximum Time Value Watchdog can be loaded with (default time)	-	-	10	sec.	
WD <sub>MIN</sub>	Minimum Time Value Watchdog can be loaded with	1.0	-	-	ms	
WD <sub>RESET</sub>	Reset Pulse Width when Watchdog times out	100	-	-	$\mu\text{s}$	
<b>VRS CONDITIONING INPUT</b>						
OUTPUT <sub>BLANK</sub>	Output Blanking Time Programming Range (% of previous out pulse 0 to 15/32 in 1/32 steps, 15/32 = 46.9%)	0	-	50	%	
OUTPUT <sub>DEGLITCH</sub>	Output Deglitch Filter Time (1/128 of the previous output pulse)	-	1.0	-	%	
DELAY <sub>THRESH</sub>	Delay from CSB to Change in VRS Comparator Threshold	-	-	10	$\mu\text{s}$	(12)
DELAY <sub>OBT</sub>	Delay from CSB to Change in VRS Output Blank Time	-	-	10	$\mu\text{s}$	(12)
<b>ISO9141 TRANSCEIVER</b>						
ISO <sub>BR</sub>	Typical ISO9141 Data Rate	-	10	-	kbps	
$t_{\text{TXDF}}$	Turn OFF Delay MTX Input to ISO Output	-	-	2.0	$\mu\text{s}$	
$t_{\text{RXDF}}, t_{\text{RXDR}}$	Turn ON/OFF Delay ISO Input to MRX Output	-	-	1.0	$\mu\text{s}$	
$t_{\text{RXR}}, t_{\text{RXF}}$	Rise and Fall Time MRX Output (measured from 10% to 90%)	-	-	1.0	$\mu\text{s}$	
$t_{\text{XR}}, t_{\text{XF}}$	Maximum Rise and Fall Time MTX Input (measured from 10% to 90%)	-	-	1.0	$\mu\text{s}$	
<b>ALL LOW-SIDE DRIVERS</b>						
$t_{\text{SC1}}$	Output ON Current Limit Fault Filter Timer	30	60	90	$\mu\text{s}$	
$t_{\text{REF}}$	Output Retry Timer	7.0	10	13	ms	
$t_{\text{INRUSH}}$	Inrush Current Delay Timer	7.0	10	13	ms	(12)
$t_{\text{(OFF)OC}}$	Output OFF Open-circuit Fault Filter Timer	100	-	400	$\mu\text{s}$	
$t_{\text{SR(RISE)}}$	Output Slew Rate, INJOUT1, IROUT1, ROUT2 and LAMPOUT • $R_{\text{LOAD}} = 500\ \Omega$ , $V_{\text{LOAD}} = 14\text{ V}$	1.0	5.0	10	V/ $\mu\text{s}$	
$t_{\text{SR(FALL)}}$	Output Slew Rate, INJOUT1, ROUT1, ROUT2 and LAMPOUT • $R_{\text{LOAD}} = 500\ \Omega$ , $V_{\text{LOAD}} = 14\text{ V}$	1.0	5.0	10	V/ $\mu\text{s}$	
$t_{\text{PHL}}$	Propagation Delay (Input Rising Edge OR CSB to Output Falling Edge) • Input at 50% $V_{\text{DD}}$ to Output voltage 90% of $V_{\text{LOAD}}$ (INJOUT1, ROUT1, ROUT2, LAMP)	-	1.0	5.0	$\mu\text{s}$	
$t_{\text{PHL}}$	Propagation Delay (Input Rising Edge OR CSB to Output Falling Edge) • Input at 50% $V_{\text{DD}}$ to Output voltage 90% of $V_{\text{LOAD}}$ (TACHOMETER)	-	1.0	6.0	$\mu\text{s}$	

Notes

12. Guaranteed by Design
13. internal oscillator of 4.0 MHz  $\pm 10\%$  typical for  $V_{\text{PWR}} = 13\text{ V}$ , at room temp.

**Table 5. Dynamic electrical characteristics (13)**

Characteristics noted under conditions of  $6.0\text{ V} \leq V_{PWR} \leq 18\text{ V}$ ,  $-40\text{ }^\circ\text{C} \leq T_{CASE} \leq 125\text{ }^\circ\text{C}$  and Calibrated Timers, unless otherwise noted. Where applicable, typical values reflect the parameter's approximate average value with  $V_{PWR} = 14\text{ V}$ ,  $T_A = 25\text{ }^\circ\text{C}$ .

Symbol	Characteristic	Min	Typ	Max	Unit	Notes
<b>ALL LOW-SIDE DRIVERS (CONTINUED)</b>						
$t_{PLH}$	Propagation Delay (Input Falling Edge OR CSB to Output Rising Edge) • Input at 50% $V_{DD}$ to Output voltage 10% of $V_{LOAD}$ (INJOUT1, ROUT1, ROUT2, LAMP)	-	1.0	5.0	$\mu\text{s}$	
$t_{PLH}$	Propagation Delay (Input Falling Edge OR CSB to Output Rising Edge) • Input at 50% $V_{DD}$ to Output voltage 10% of $V_{LOAD}$ (TACHOMETER)	-	1.0	6.0	$\mu\text{s}$	
$t_{SR(FALL)}$	Output Slew Rate, Tachout • $R_{LOAD} = 500\ \Omega$ , $V_{LOAD} = 14\text{ V}$	6.0	-	14	$\text{V}/\mu\text{s}$	

**ALL GATE PRE-DRIVER (IGN1, AND O2H)**

$t_{(OFF)OC}$	Output OFF Open-circuit Fault Filter Timer	100	-	400	$\mu\text{s}$	
$t_{SC1}$	Overcurrent (short-circuit) Fault Filter Timer	30	-	90	$\mu\text{s}$	
$t_{PLH}$	Propagation Delay (Input Rising Edge OR CSB to Output Rising Edge) • Input at 50% $V_{DD}$ to Output voltage 10% of $V_{GS(ON)}$	-	1.0	5.0	$\mu\text{s}$	
$t_{PHL}$	Propagation Delay (Input Falling Edge OR CSB to Output Falling Edge) • Input at 50% $V_{DD}$ to Output voltage 90% of $V_{GS(ON)}$	-	1.0	5.0	$\mu\text{s}$	

**SPI DIGITAL INTERFACE TIMING (14)**

$t_{LEAD}$	Falling Edge of CSB to Rising Edge of SCLK • Required Setup Time	100	-	-	ns	
$t_{LAG}$	Falling Edge of SCLK to Rising Edge of CSB • Required Setup Time	50	-	-	ns	
$t_{SI(SU)}$	SI to Rising Edge of SCLK • Required Setup Time	16	-	-	ns	
$t_{SI(HOLD)}$	Rising Edge of SCLK to SI • Required Hold Time	20	-	-	ns	
$t_{R(SI)}$	SI, CSB, SCLK Signal Rise Time (15)	-	5.0	-	ns	
$t_{F(SI)}$	SI, CSB, SCLK Signal Fall Time (15)	-	5.0	-	ns	
$t_{SO(EN)}$	Time from Falling Edge of CSB to SO Low-impedance (16)	-	-	55	ns	
$t_{SO(DIS)}$	Time from Rising Edge of CSB to SO High-impedance	-	-	55	ns	
$t_{VALID}$	Time from Falling Edge of SCLK to SO Data Valid (17)	-	25	55	ns	
$t_{STR}$	Sequential Transfer Rate (14) • Time required between data transfers	-	-	1.0	$\mu\text{s}$	

## Notes

14. These parameters are guaranteed by design. Production test equipment uses 1.0 MHz, 5.0 V SPI interface (variable with magnitude input frequency).
15. Rise and Fall time of incoming SI, CSB and SCLK signals suggested for design consideration to prevent the occurrence of double pulsing.
16. Time required for output states data to be terminated at SO pin.
17. Time required to obtain valid data out from SO following the fall of SCLK with 200 pF load.



## 4.4 Timing diagrams

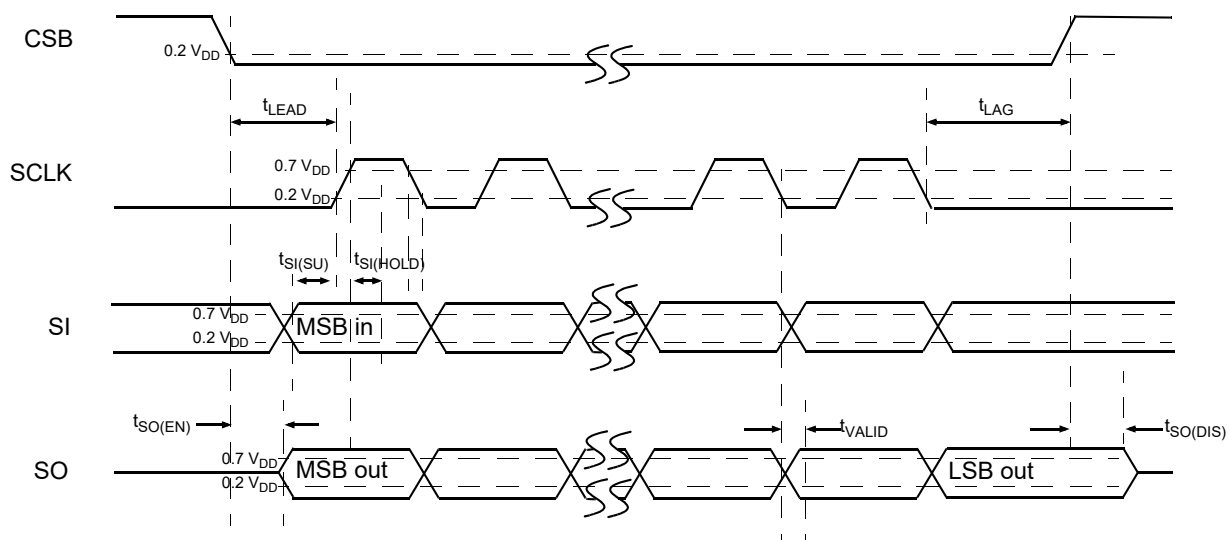

Figure 4. Timing diagram

## 4.5 Typical electrical characteristics

### 4.5.1 Driver and gate driver characteristics

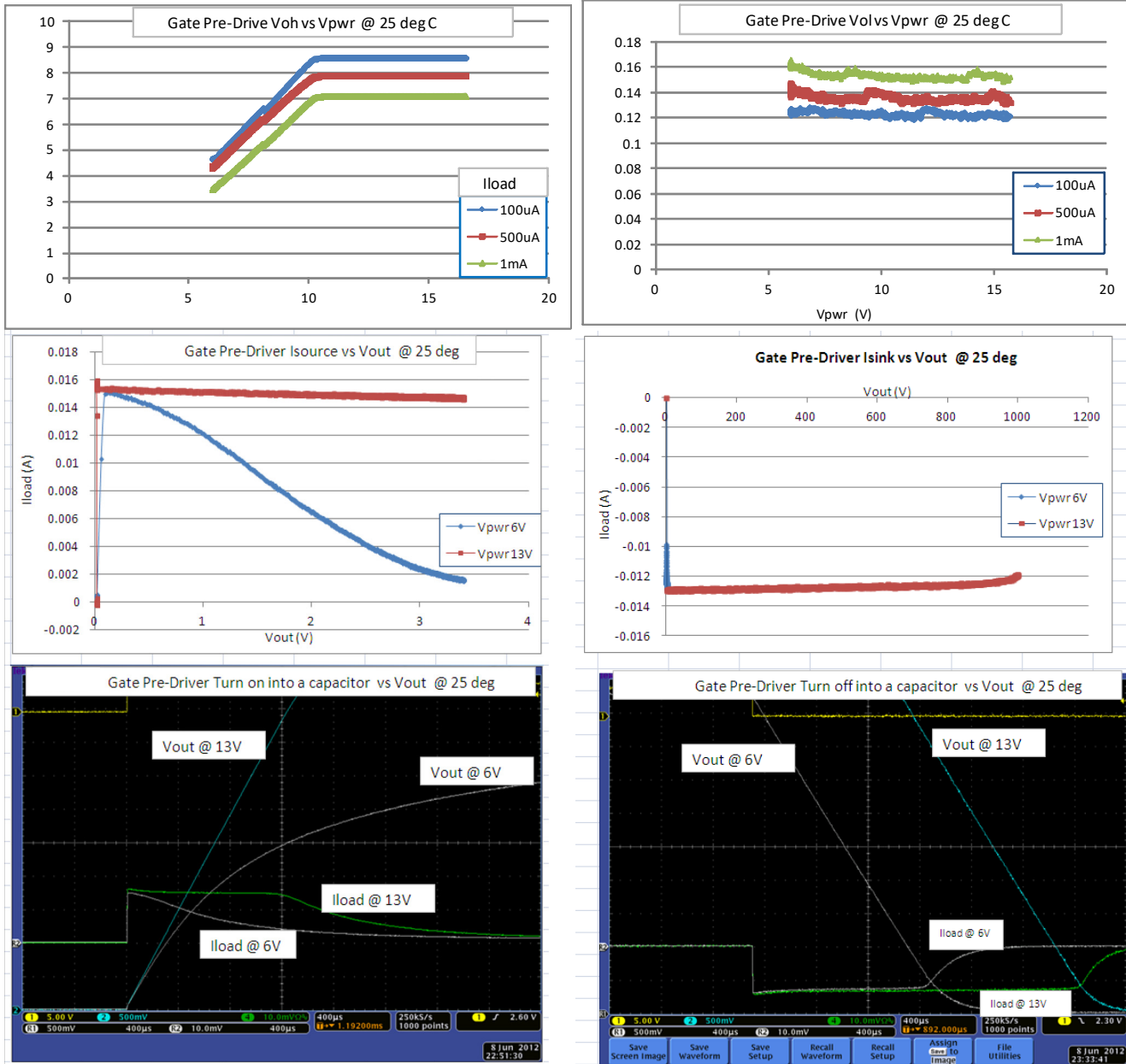

Figure 5. Typical electrical specifications

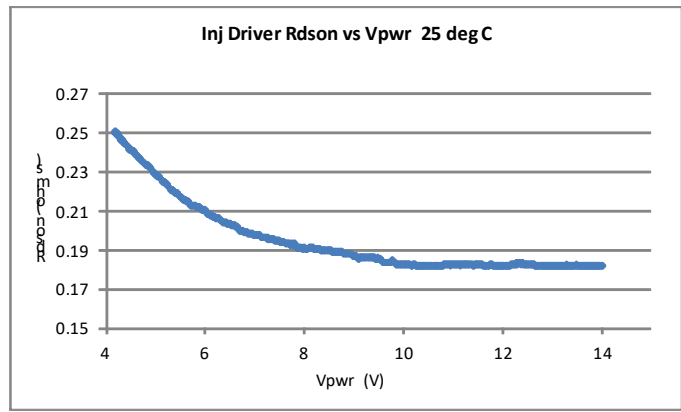

Figure 6. Typical electrical specifications (continued)

### 4.5.2 V<sub>CC</sub> and V<sub>PROT</sub> characteristics

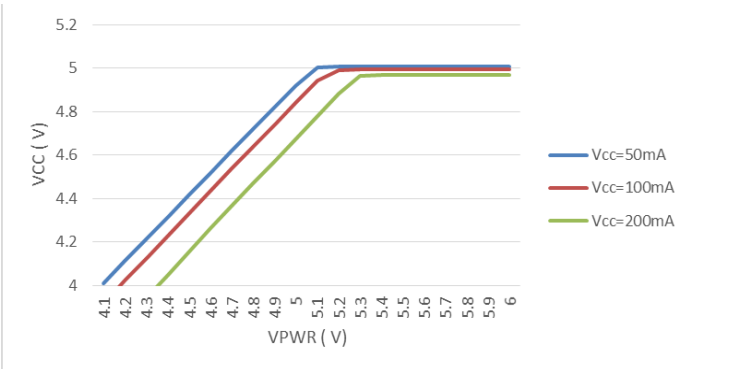

Figure 7. V<sub>CC</sub> voltage vs. V<sub>PWR</sub> at 125 °C

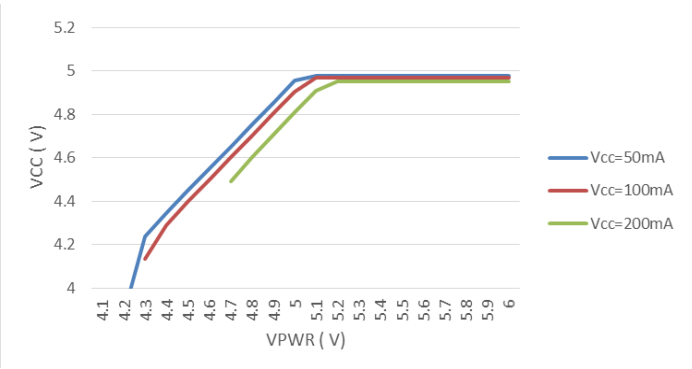

Figure 9. V<sub>CC</sub> voltage vs. V<sub>PWR</sub> at -40 °C

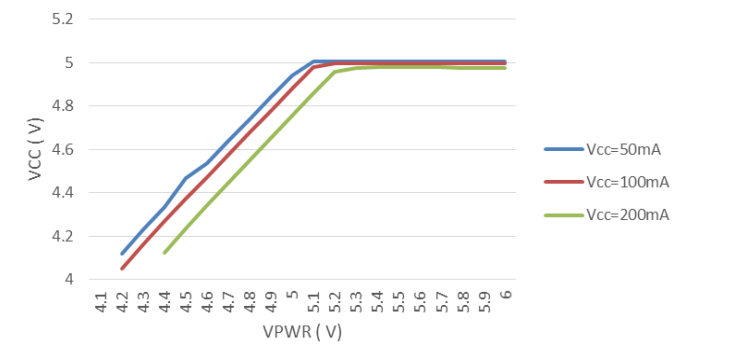

Figure 8. V<sub>CC</sub> voltage vs. V<sub>PWR</sub> at 25 °C

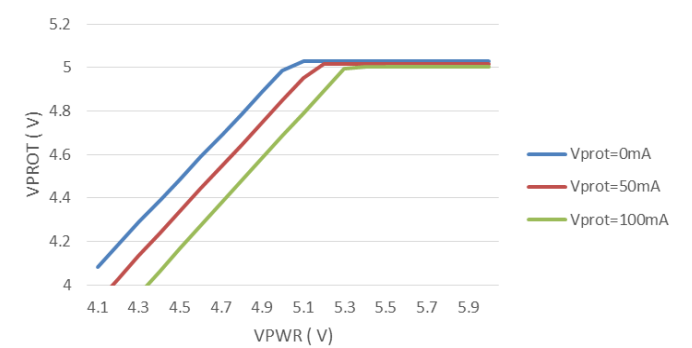

Figure 10. V<sub>PROT</sub> voltage vs. V<sub>PWR</sub> at 125 °C

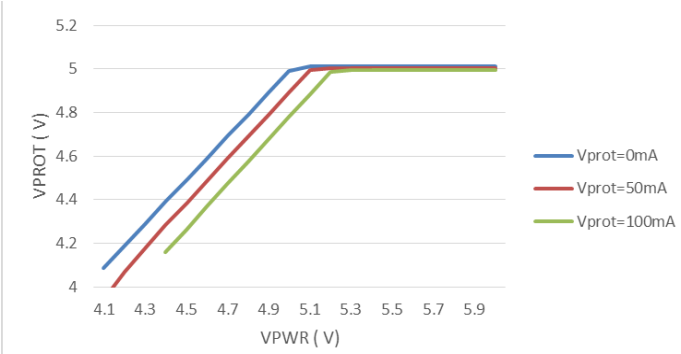

Figure 11. V<sub>PROT</sub> voltage vs. V<sub>PWR</sub> at 25 °C

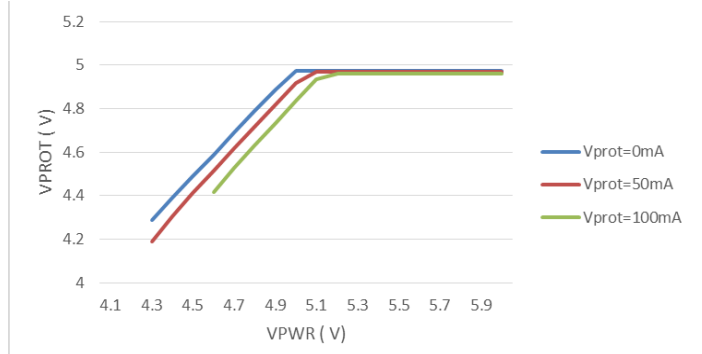

Figure 12. V<sub>PROT</sub> voltage vs. V<sub>PWR</sub> at -40 °C

# 5 General IC functional description and application information

## 5.1 System controller

### 5.1.1 System control signals

#### 5.1.1.1 KEYSW input pin

KEYSW is the input from the vehicle ignition key switch. This signal is at  $V_{BAT}$  (12 V) when the key is inserted and turned to the ON position. When the key is in the OFF position and/or removed from the key switch, this input is pulled to ground by an internal pull-down resistor. This pin is internally protected against a reverse battery condition by an internal diode. The state of the KEYSW input is also available as a bit in the SPI Status Register.

#### 5.1.1.2 BATSW output pin

The BATSW output pin is a 5.0 V logic level output, which by default is an indication of the state of the KEYSW input.

#### 5.1.1.3 PWREN SPI control register BIT

The PWREN signal is a bit in the SPI Control Register #1 allowing "Prepare to shutdown" state transition.

### 5.1.2 Operating modes

#### 5.1.2.1 Power On Reset (POR)

Applying  $V_{PWR}$  and bringing KEYSW high ( $V_{BAT}$ ), longer than the KEYSW filter time, generates a Power On Reset (POR) and places the device in the Normal operating state. The Power On Reset circuit incorporates a timer to prevent high frequency transients from causing an erroneous POR. Upon enabling the device (KEYSW High), outputs are activated based on the initial state of the control register or parallel input. All three supplies,  $V_{PP}$ ,  $V_{CC}$  and  $V_{PROT}$ , are enabled when KEYSW is brought high.

Table 6. Operational states

KEYSW Input	PWREN SPI Bit Input	BATSWB Output	All Supplies	STATE
L	L	L	OFF	Sleep
H	L	H	ON	NORMAL
H	H	H	ON	NORMAL
L	H	L	ON	Prepare to shutdown

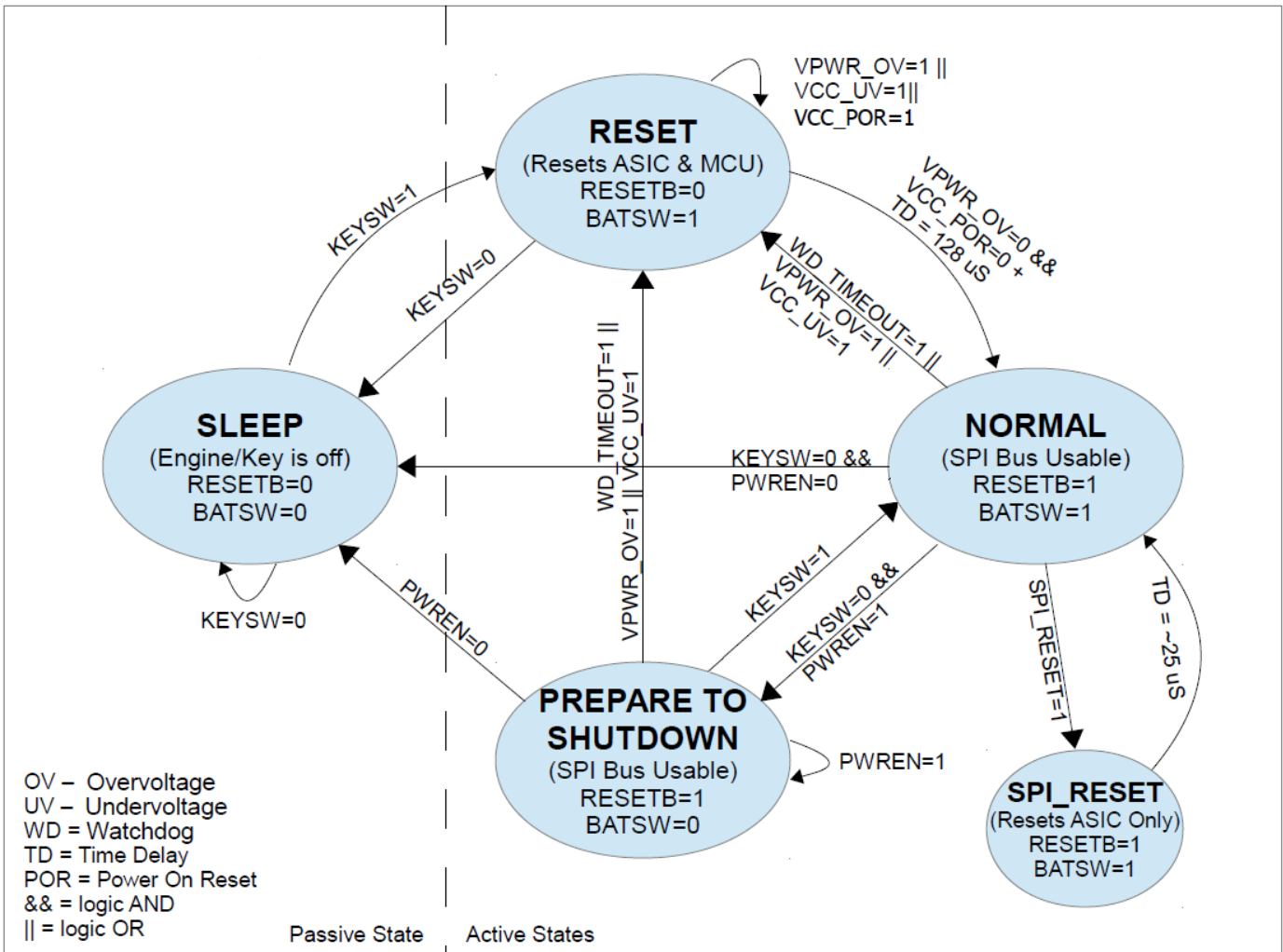

Figure 13. 33813 functional state diagram

### 5.1.2.2 Normal state

The default Normal state is entered when power is applied to the VPWR and KEYSW pins. Note that the device is designed to have VPWR present before KEYSW is brought high. It is acceptable to bring VPWR and KEYSW high simultaneously. However it is not recommended to bring KEYSW high while VPWR is low.

SPI register settings from Power On Reset (POR) are as follows:

- All outputs turned off
- Off State open load detection enabled (LSD)
- Default values in the SPI Configuration, Control and Status registers

### 5.1.2.3 Sleep state

When KEYSW signal is low and the PWREN SPI Control register bit is also low, the 33813 enters into Sleep mode. In the Sleep state, all outputs, current sources and sinks are off and the device consumes less than  $I_{VPWR(SS)}$ . When KEYSW signal goes high, it wakes up the IC, turns on the  $V_{PP}$  regulator and a Power On Reset signal is generated.

### 5.1.2.4 Prepare to shutdown state

The purpose of the PWREN signal is to allow the MCU to control the shutdown of power to itself when the user turns off the KEYSW. This may be necessary to allow the MCU the time required to perform its pre-shutdown routines. When the MCU wants to shutdown the power supplies in the 33813, it must write a logic zero (0) to the PWREN bit in the SPI Control register. Only the state of the PWREN bit in the SPI Control register controls the shutdown of the 33813 power supplies. In this state, only the outputs are turned off (except ROUT2 if the Shutdown Disable bit is set. See [5.5.3.3. Using ROUT2 as a power relay, page 37](#)).

Note: In case of KEYSW = 1 condition, 33813 goes back in Normal mode, retrieving the last register configuration. This suggests that before entering in Prepare to Shutdown mode, user needs to configure registers as appropriate (switching off drivers and pre-drivers for example).

### 5.1.2.5 Power On Self-test (POST)

When a power on occurs after a POR, it may be desired to go through an initial Power On Self-test routine to ensure the SPI is working correctly and the status registers in the 33813 are viable. After a POR, all the registers in the 33813 contain their 'default' values, as indicated in the SPI register tables later in this document. The watchdog is also set to its default timeout value of 10 seconds, so any POST routine must be accomplished within this time frame or a WD reset may occur.

To perform a POST routine, the MCU should first send a SPI message to set the POST enable bit in the SPI control register 1, bit 6. Once this bit is set, the status registers are disconnected from the analog and logic portions of the 33813 and are connected only to the SPI circuitry. The POST can then write various data patterns to the status registers and verify that none of the bits are 'stuck' and state of the bit is accurately reflected. Note that bits in the status register labeled 'x' are not implemented and testing these bits may result in erroneous data. After testing all the status registers and confirming they are viable, the status registers can be set back to their default values by clearing the POST Enable bit back to 0. The POST enable bit allows the MCU to write ones (1s) to the Status registers.

Normally, the status register can only be cleared to zeros by the MCU and ones can be written to the status register only by the 33813 internal logic. This is designed to prevent the MCU from missing any reported fault bits and, for the 33813, to prevent system status errors resulting from the MCU erroneously writing a one (1) to a fault bit.

Once the POST enable bit is set back to a zero (0) by the MCU, the status register returns to the condition where the 33813 can only write ones(1s) to it and the MCU can only write zeros (0s) to it. Again, it is important to note that any POST routine should be designed to take less than 10 seconds to avoid a watchdog reset from occurring and truncating the POST routine, because the WD reset clears the POST Enable bit as well.

## 5.1.3 BATSW output functionality

The BATSW output pin has several functionalities:

- By default, the BATSW output pin is an indication of the state of the KEYSW input.
- The BATSW output can also be used to control an LS driver, such as the Relay ROUT2 driver by connecting the BATSW output to the RIN2 input.
- The BATSW output can also be configured as a low current LED high-side driver controlled through the SPI interface.

### 5.1.3.1 BATSW pin as a KEYSW input indication

When KEYSW is at  $V_{BAT}$  (12 V) level, the BATSW output is a logic 1 (5.0 V) and when KEYSW is at ground (0 V) level, BATSW is at a logic 0. The BATSW output may be used to inform the MCU the user is trying to shutdown the vehicle.

### 5.1.3.2 BATSW pin as an LS driver control

The BATSW output can also be used to control an LS driver, such as the Relay ROUT2 driver, by connecting the BATSW output to the RIN2 input. (see [5.5.3.3. Using ROUT2 as a power relay, page 37](#))

### 5.1.3.3 BATSW pin as an LED driver

If the BATSW signal is not needed by the MCU or to control the Relay 2 output, it can be configured as a low current LED high-side driver controlled through the SPI interface. As a high-side driver, BATSW can be PWM'd to allow an LED to be dimmed. A bit in the SPI Battery Switch Logic Output Configuration register called 'HSD', controls whether the BATSW output is a simple high-side driver, or controlled by KEYSW as indicated previously.

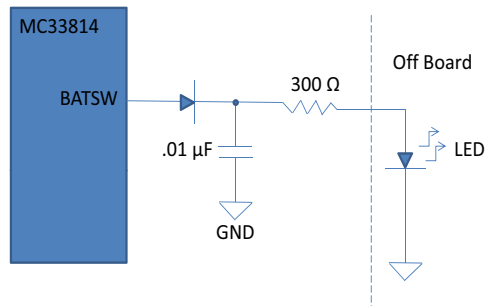

Figure 14. Recommended Circuit to Use BATSW as an LED Driver

If the BATSW output is used to control an LED, the LED cathode should be tied to ground and the LED anode should be connected to the BATSW pin through an external resistor. The value of the external resistor should be 340 Ω or greater. Care must be taken if the BATSW output is sent off-board due to the chance of shorts to the battery or shorts to ground, for which the output is not protected. At a minimum, this output should be protected by a diode, a current limit resistor and an ESD capacitor (0.01 μF ceramic).

## 5.1.4 System SPI registers

### 5.1.4.1 SPI configuration registers

Table 7. Battery switch logic output configuration register

Reg #	Hex			7	6	5	4	3	2	1	0
6	6	Battery Switch Logic Output		HSD mode	x	x	x	x	x	PWM Freq.1	PWM Freq. 0
			Reset	(0)	(0)	(0)	(0)	(0)	(0)	(0)	(0)

Table 8. Battery switch logic output configuration register field

Field	Description
7-HSD mode	BATSW mode selection 0 - BATSW is controlled by KEYSW 1 - BATSW is used as a high-side driver
1-0 PWM Freq.x	PWM Frequency and Duty Cycle mode <sup>(18)</sup> 00 - PWM Freq.: None 01 - PWM Freq.:100 HZ-D/C: Internal 10 - PWM Freq.: 1 kHz-D/C: Internal

Notes

18. See 5.5.2.2. Pulse Width Modulation mode, page 35

### 5.1.4.2 SPI control registers

Table 9. Other OFF/ON control register

Reg #	Hex			7	6	5	4	3	2	1	0
1	1	Other OFF/ON Control		Pwren OFF/ON	POST Enable OFF/ON	X	VProt ON/OFF	X	Batsw OFF/ON	Tach OFF/ON	RESET internal only
			Reset	(0)	(0)	(0)	(1)	(0)	(0)	(1)	(0)
8	8	Batsw		X	PWM6	PWM5	PWM4	PWM3	PWM2	PWM1	PWM0
			Reset	(0)	(0)	(0)	(0)	(0)	(0)	(0)	(0)



**Table 10. Other OFF/ON control register field description**

Field	Description
7-Pwren OFF/ON	Power Enable 0-Power Disable (allowing sleep mode entry) 1-Power Enable (allowing Prepare to Shutdown mode entry)
6-POST Enable OFF/ON	Power On Self Test Enable 0-POST Disable 1-POST Enable
2-BATSW OFF/ON	BATSW Output Control 0-BATSW Output OFF 1-BATSW Output ON

**Table 11. BATSW control register field description**

Field	Description
6-0 PWM x	PWM Duty Cycle Setting with 1% increment 0000000 to 1100100 (Dec. 100) represent 0% to 100% 1100100 (Dec. 100) to 1111111 (Dec.127) all map to 100%.

### 5.1.4.3 SPI status registers

**Table 12. Power supply and any system fault status register**

Reg #	Hex			7	6	5	4	3	2	1	0
13	D	Power Supply and Any System Faults		Any System Faults	Keysw	Pwren	Batsw	SPI Error	V <sub>PROT</sub> Short to Battery	V <sub>PROT</sub> Overtemp OT	V <sub>PROT</sub> Short to Ground
			Reset	(0)	(1)	(0)	(0)	(0)	(0)	(0)	(0)

**Table 13. Power supply and any system fault status register field description**

Field	Description
7-Any System Fault	System-wide any fault bit whose stats is the OR of all the other "Any fault" bits in the other status 0-No Fault reported 1-At least one Fault is reported <sup>(19)</sup>
6-Keysw	KEYSW Pin Status: 0-KEYSW is high (V <sub>BAT</sub> Present) 1-KEYSW is low (Prepare to Shutdown mode)
5-PWREN	PWREN Status 0-PWREN Control bit is low 1-PWREN Control bit is high
4-Batsw	BATSW Pin Status 0-BATSW Pin is low 1-BATSW Pin is high

Notes

19. The MCU must interrogate all the other status registers to determine the actual fault(s) present.

## 5.2 Watchdog

### 5.2.1 Watchdog Normal operation

The watchdog is a programmable timer used to monitor the operation of the MCU. The timer programming is done by the Watchdog Parameters SPI Configuration Register by selection the Time Multiplier Value (bit 6-4) and the Time Value (bit 3-0).

Watchdog Timer = Time Multiplier Value (1.0 s, 100 ms, or 10 ms) X Time Value (1 to 10)

Using this technique, time values from 1.0 ms. to 10 seconds can be programmed into the watchdog. (default value is 10 s)

When the MCU is executing code properly, its program code should contain instructions to periodically send a SPI message to the watchdog SPI control register to refresh the watchdog. The watchdog timer, once refreshed, reloads the time interval value stored in the SPI watchdog configuration register and begins counting time again. Under normal operating conditions this sequence continues until the MCU shuts down, typically, when the KEYSW is turned off.

### 5.2.2 Watchdog Fault operation

In the event that something goes wrong during the MCU program execution, such as an unexpected breakpoint or some other program hang-up such as the execution of a HALT instruction, the watchdog may not be refreshed. When the WD time interval value programmed in the SPI Configuration register elapses, the watchdog issues a RESETB pulse. This RESETB pulse causes the MCU to restart its program and correct operation should be restored. After any RESETB (power-on or other), the watchdog SPI configuration register contains the default value for the refresh time (10 seconds). The watchdog is also enabled by default. The MCU, in its initialization (start-up) code, can choose to change this default value and/or disable the watchdog by sending a SPI command to write new information in the watchdog SPI configuration register.

### 5.2.3 Disabling the Watchdog timer

A watchdog reset occurs, by default, 10 seconds after the POR. If the MCU needs to be programmed in-circuit, a means of disabling the watchdog must be provided to avoid interrupting the MCU programming procedure. This disable mechanism can be a jumper between the RESETB pin of the 33813 and the MCU's Reset input pin. Alternatively, an isolation resistor can be placed between the RESETB pin on the 33813 and the MCU's reset input pin, allowing the MCU's reset pin to be pulled high independently of the 33813 RESETB. The watchdog can also be disabled via a bit in the SPI WD configuration register.

### 5.2.4 Watchdog SPI register

#### 5.2.4.1 Watchdog SPI configuration register

Table 14. Watchdog parameters configuration registers

Reg #	Hex		7	6	5	4	3	2	1	0
10	A	Watchdog Parameters	Disable/ Enable	Load Time x1 sec	Load Time x100 ms	Load Time x10 ms	Load Time 8	Load Time 4	Load Time 2	Load Time 1
		Reset	(1)	(1)	(0)	(0)	(1)	(0)	(1)	(0)

Table 15. Watchdog parameter - register field descriptions

Field	Description
7-Disable/Enable	Watchdog Enable/Disable 0-Watchdog Disable 1-Watchdog Enable (Default State)
6-Load Time x1 sec	Time Multiplier Value <sup>(20)</sup> 0- Disable 1- Multiplier value = 1.0 sec (Default State)
5-Load Time x100 ms	Time Multiplier Value <sup>(20)</sup> 0- Disable (Default State) 1- Multiplier value = 100 ms

**Table 15. Watchdog parameter - register field descriptions**

Field	Description
4-Load Time x10 ms	Time Multiplier Value <sup>(20)</sup> 0- Disable (Default State) 1- Multiplier value = 10 ms
3-0 Load Time Value	Bits 3, 2, 1, 0 are a binary coded decimal (BCD) value from 1 to 10. (11 to 16 are mapped to 10 and 0 is mapped to 1) Default state = 1010 = X10

Notes

20. There are three time multiplier values so only one bit, 6, 5, or 4 may be set at one time. Setting more than one bit results in the highest multiplier value getting precedence.

## 5.2.4.2 Watchdog SPI control register

**Table 16. Watchdog control registers**

Reg #	Hex		7	6	5	4	3	2	1	0
12	C	Watchdog	WDRFSH	Load Time x1 sec	Load Time x100 ms	Load Time x10 ms	Load Time 8	Load Time 4	Load Time 2	Load Time 1
		Reset	(0)	(0)	(0)	(0)	(0)	(0)	(0)	(0)

**Table 17. Watchdog control - register field descriptions**

Field	Description
7-WDRFSH	Watchdog Refresh 0-No Watchdog refresh action 1-Refresh the watchdog timer. (reload the time value from the Watchdog Parameters Register)
6-Load Time x1 sec	Temporary Time Multiplier Value <sup>(21)</sup> 0- Disable 1- Multiplier value = 1.0 sec
5-Load Time x100 ms	Temporary Time Multiplier Value <sup>(21)</sup> 0- Disable 1- Multiplier value = 100 ms
4-Load Time x10 ms	Temporary Time Multiplier Value <sup>(21)</sup> 0- Disable 1- Multiplier value = 10 ms
3-0 Load Time Value	Bits 3, 2, 1, 0 are a Temporary Binary coded decimal (BCD) value from 1 to 10. (11 to 16 are mapped to 10 and 0 is mapped to 1)

Notes

21. There are three time multiplier values so only one bit, 6, 5, or 4 may be set at one time. Setting more than one bit results in the highest multiplier value getting precedence.

Note: The watchdog SPI Control Register can also be loaded with a time value to temporarily set a different value in the watchdog timer for the next cycle. When Bits 6 thru 0 in the watchdog SPI control register are zero, the value stored in the watchdog SPI configuration register loads into the watchdog timer. If there is a temporary time value written into the watchdog SPI control register, the value loads into the watchdog. The watchdog SPI control register is automatically cleared to zero when the watchdog timer is loaded. Unless a new temporary time value is again written to the watchdog SPI Control Register, the next watchdog timer load is from the value stored in the watchdog SPI configuration register,

## 5.2.4.3 Watchdog SPI status register

Table 18. Watchdog status register

Reg #	Hex			7	6	5	4	3	2	1	0
10	A	Watchdog State		Enable/ Disable	WD timer bit 6	WD timer bit 5	WD timer bit 4	WD timer bit 3	WD timer bit 2	WD timer bit 1	WD timer bit 0
			Reset	(0)	(0)	(0)	(0)	(0)	(0)	(0)	(0)

Table 19. Watchdog status - register field descriptions

Field	Description
7-Enable/Disable	Watchdog Enable/Disable Status 0-Watchdog disable 1-Watchdog Enable
6-0 WD Timer bit x	Reflecting the Watchdog Timer value Each step represents the WD timer/127

Bits [6:0] represent the value stored in the watchdog timer. If the watchdog is enabled, this value read on the fly represents the time left before a watchdog reset.

Table 20. Watchdog timer values

Status register							Value in ms
WD timer bit6	WD timer bit5	WD timer bit4	WD timer bit3	WD timer bit2	WD timer bit1	WD timer bit0	
0	0	0	0	0	0	1	1
0	0	0	0	0	1	0	2
0	0	0	0	0	1	1	3
0	0	0	0	1	0	0	4
0	0	0	0	1	0	1	5
0	0	0	0	1	1	0	6
0	0	0	0	1	1	1	7
0	0	0	1	0	0	0	8
0	0	0	1	0	0	1	9
0	0	1	0	0	0	1	10
0	0	1	0	0	1	0	20
0	0	1	0	0	1	1	30
0	0	1	0	1	0	0	40
0	0	1	0	1	0	1	50
0	0	1	0	1	1	0	60
0	0	1	0	1	1	1	70
0	0	1	1	0	0	0	80
0	0	1	1	0	0	1	90
0	1	0	0	0	0	1	100
0	1	0	0	0	1	0	200
0	1	0	0	0	1	1	300
0	1	0	0	1	0	0	400
0	1	0	0	10	0	1	500
0	1	0	0	1	1	0	600

**Table 20. Watchdog timer values (continued)**

0	1	0	0	1	1	1	700
0	1	0	1	0	0	0	800
0	1	0	1	0	0	1	900
1	0	0	0	0	0	1	1000
1	0	0	0	0	1	0	2000
1	0	0	0	0	1	1	3000
1	0	0	0	1	0	0	4000
1	0	0	0	1	0	1	5000
1	0	0	0	1	1	0	6000
1	0	0	0	1	1	1	7000
1	0	0	1	0	0	0	8000
1	0	0	1	0	0	1	9000
1	0	0	1	0	1	0	10000

## 5.3 System reset

### 5.3.1 RESETB output pin

The RESETB pin is a 5.0 volt logic, low level output used to reset the MCU. The RESETB pin is an open drain output. Without power on the 33813 circuit, the RESETB pin is held low by an internal pull-down resistor. In a typical application, the RESETB pin must be pulled up externally by a pull-up resistor to VCC.

### 5.3.2 Reset sources

When power is applied to the circuit and the voltage on the VCC pin reaches the lower voltage threshold, the RESETB pin remains at a low level (open drain FET turned on) for a period of time equal to the time value  $WD_{RESETB}$ . After this time period, the RESETB pin goes high and stays high until a reset pulse is generated due to any of the following events:

- A watchdog timer timeout event occurs
- An undervoltage event on VCC occurs
- An overvoltage event on VPWR occurs

A Power On Reset (POR) is always provided upon power ON (anytime the IC goes from sleep state to active state).

### 5.3.3 Internal reset

The SPI control register includes a bit labeled 'Reset'. When this bit is set to a one (1) by the MCU, it instructs the 33813 to perform an internal reset. This reset does NOT toggle the RESETB output pin. However, it causes all internal registers to be initialized back to their default values (including clearing the reset bit in the SPI control register).

**Table 21. Other OFF/ON control register**

Reg #	Hex		7	6	5	4	3	2	1	0	
1	1	Other OFF/ON Control		Pwren OFF/ON	POST Enable OFF/ON	X	VProt ON/OFF	X	Batsw OFF/ON	Tach OFF/ON	RESET internal only
			Reset	(0)	(0)	(0)	(1)	(0)	(0)	(1)	(0)

**Table 22. Other OFF/ON register field descriptions**

Field	Description
0-RESET Internal Only	Reset Internal Only Command 0-Do not perform an internal reset 1-Perform an internal reset

## 5.4 Power supplies

### 5.4.1 Pin description

#### 5.4.1.1 PWR supply input

The VPWR pin is the battery input to the 33813 IC. The VPWR pin requires an external reverse battery and adequate transient voltage protection. The VPWR pin should be bypassed to ground, as close to the IC as possible, with a 0.1  $\mu\text{F}$  ceramic capacitor.

#### 5.4.1.2 VPPREF output

The VPPREF output pin is used to drive the base of an external regulator PNP pass transistor. It is not recommended that this voltage be brought off of the module PC board, because it may not have adequate protection to prevent damage to the PNP pass transistor under short-to-ground or short-to-battery conditions.

#### 5.4.1.3 VPPSENS input

The VPPSENS pin is used to monitor the  $V_{PP}$  pre-regulator output voltage from the external pass transistor's collector and to supply the input voltage to the  $V_{CC}$  and  $V_{PROT}$  regulators. The VPPSENS pin should be bypassed to ground, as close to the IC as possible, with a 0.1  $\mu\text{F}$  ceramic capacitor and a higher value electrolytic capacitor in parallel. The VPPSENS pin should not be used to supply other components. The external regulator PNP pass transistor should be dedicated to the 33813.

#### 5.4.1.4 VCC output (5.0 V supply)

The VCC output supplies 5.0 V power to the system MCU and other on-board peripherals. An external capacitor  $V_{OCE}$  is recommend.

#### 5.4.1.5 VPROT output (5.0 V protected supply)

The VPROT Output is a protected 5.0 Volt output that tracks the  $V_{CC}$  voltage. The VPROT output should be protected against ESD by means of a 0.1  $\mu\text{F}$  ceramic capacitor on the output and a higher value electrolytic capacitor in parallel. An external capacitor  $V_{OCE}$  is also recommended.

#### 5.4.1.6 GND

The GND pin provides the ground reference for the  $V_{PWR}$ ,  $V_{PP}$ ,  $V_{PROT}$  and  $V_{CC}$  supplies. The GND pin is used as a return for both the power supplies, as well as power a ground for some of the lower current output drivers. The higher current output drivers have their own ground pins. All ground pins (INJGND1, INJGND2, RGND1 and RGND2) and the exposed pad must be directly connected to this pin and to the negative battery terminal. There is no separate ground pin associated with the LAMPOUT driver. It shares a ground with ROUT2.

### 5.4.2 Power supplies functions

#### 5.4.2.1 Power supply

The 33813 is designed to operate from  $VPWR_{MIN}$  to  $VPWR_{MAX}$  on the VPWR pin. The VPWR pin supplies power to all internal regulators and analog and logic circuit blocks. All IC analog current and internal logic current is provided from the VPWR pin. An overvoltage comparator monitors this pin. When an overvoltage condition is present, all outputs and voltage regulators are shut off for protection.

## 5.4.2.2 V<sub>PP</sub> pre-regulator

The V<sub>PP</sub> pre-regulator supplies the input voltage to the V<sub>CC</sub> and V<sub>PROT</sub> regulators. The V<sub>PP</sub> regulator is a low drop-out (LDO) regulator. It provides a regulated output voltage when the input is greater than its specified voltage level and it follows the input voltage when it is below its specified voltage level.

The V<sub>PP</sub> regulator uses an external PNP transistor as a pass element. This allows the user to choose the PNP's size and package considerations to meet the system requirements. The amount of power the external PNP transistor has to dissipate depends on the maximum voltage the system can be expected to run at and the maximum expected current drawn from the V<sub>CC</sub> and V<sub>PROT</sub> regulators. The VPPSENS pin is used to feedback the value of the V<sub>PP</sub> voltage for regulation. Since the V<sub>PP</sub> regulator is not intended to supply off-board loads, there is no short-to-ground or short-to-battery protection on the output of the external PNP.

## 5.4.2.3 V<sub>CC</sub> regulator

The V<sub>CC</sub> regulator obtains its input voltage from the V<sub>PP</sub> pre-regulator. The V<sub>CC</sub> regulator output is used for supplying 5.0 V to the MCU and for setting communication threshold levels via the internal SPI SO driver. The V<sub>CC</sub> regulator contains an internal pass transistor protecting against overcurrent.

A Power On Reset (POR) circuit monitors the V<sub>CC</sub> output voltage level. When the V<sub>CC</sub> voltage exceeds the V<sub>CC(POR)</sub> threshold, the RESETB line is held low for an additional delay time t<sub>(POR)</sub> before being brought to a logic one level. An undervoltage (UV) circuit monitors the output of the V<sub>CC</sub> regulator. When the voltage goes below the V<sub>CC(UV)</sub> threshold for more than the V<sub>CC</sub> filter time, t<sub>(VCC-UV)</sub>, the RESETB line is asserted to a logic zero state and remains there until the POR condition is met.

## 5.4.2.4 V<sub>PROT</sub> regulator

The protected output V<sub>PROT</sub> is a tracking regulator using the V<sub>CC</sub> output as a reference. Because the V<sub>PROT</sub> regulator is expected to supply 5.0 V to external sensors and other off-board peripherals in the vehicle, it is well protected against shorts-to battery, shorts-to-ground, overcurrent and overtemperature. The V<sub>PROT</sub> supply is enabled at power-on, but can be disabled via the SPI Control Register.

## 5.4.2.5 Power up sequence

**Table 23. Power up sequence**

t	Actions
t0	Battery connected to VPWR Pin
t1	User turns on ignition switch, KeySw => High <ul style="list-style-type: none"> <li>Internal regulators, band gap reference and bias current generator are enabled</li> </ul>
t2 = t1+ ~5.0 μs	Internal PORb de-asserted after internal 2.5 V regulator to the logic core stabilizes <ul style="list-style-type: none"> <li>Logic and oscillator are enabled</li> <li>Start KeySw filter time</li> </ul>
t3 = t2+ ~12.7 ms	KeySW filter time period expires <ul style="list-style-type: none"> <li>Enable V<sub>PP</sub> pre-regulator</li> <li>Soft start sets turn on ramp to ~ 400 μs</li> </ul>
t4 = t3+ (< 400 μs)	V <sub>PPSENS</sub> exceeds 4.8 V, enables V <sub>CC</sub> & V <sub>PROT</sub> regulators <ul style="list-style-type: none"> <li>Soft start sets turn on ramps to ~ 2.0 ms</li> <li>BatSw buffer receives power</li> <li>Output rises with V<sub>CC</sub></li> </ul>
t5 = t4+ (< 2.0 ms)	V <sub>CC</sub> exceed POR Threshold ~4.6 V <ul style="list-style-type: none"> <li>Start POR Timing ~128 μs</li> </ul>
t6 = t5+ ~128 μs	POR Time period expires <ul style="list-style-type: none"> <li>Release RESETB pin</li> </ul>

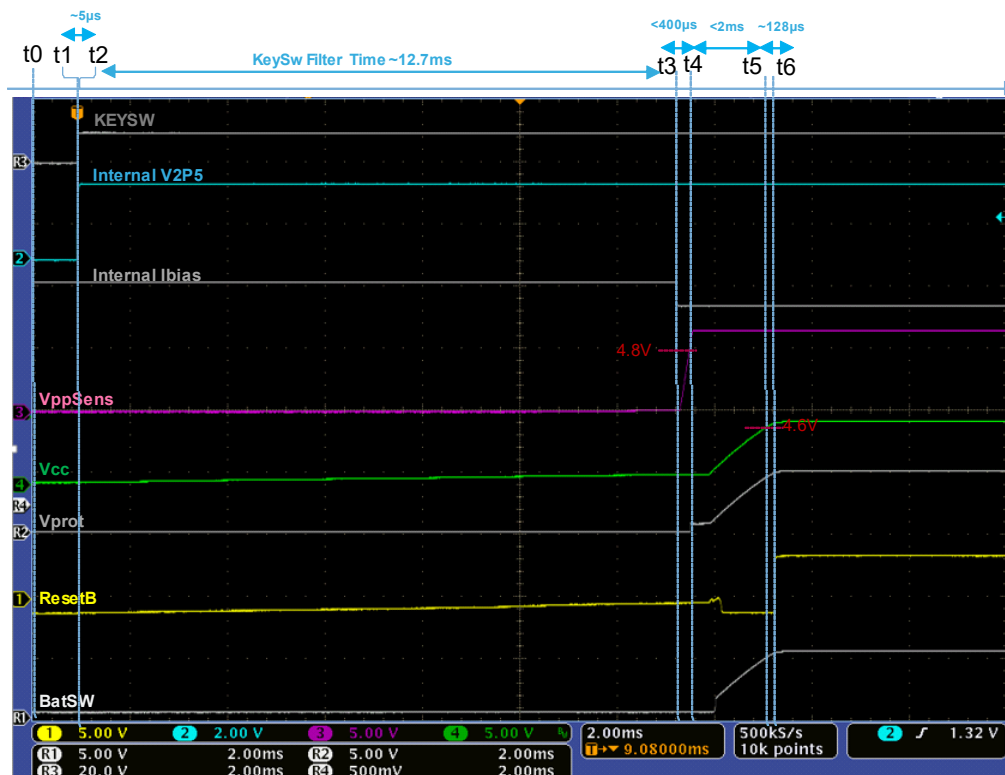

Figure 15. Power up sequence

## 5.4.3 Power supply SPI register

### 5.4.3.1 SPI control registers

Table 24. OFF/ON control register

Reg #	Hex		7	6	5	4	3	2	1	0
1	1	Other OFF/ON Control	Pwren OFF/ON	POST Enable OFF/ON	X	VProt OFF/ON	X	Batsw OFF/ON	Tach OFF/ON	RESET internal only
			Reset	(0)	(0)	(0)	(1)	(0)	(0)	(1)

Table 25. Other OFF/ON register field descriptions

Field	Description
4-VPROT OFF/ON	VPROT Regulator Enable 0-Disable 1-Enable (Default)



## 5.4.3.2 SPI status registers

Table 26. Power supply and any system fault status register

Reg #	Hex			7	6	5	4	3	2	1	0
13	D	Power Supply and Any System Faults		Any System Faults	Keysw	Pwren	Batsw	SPI Error	V <sub>PROT</sub> Short to Battery	V <sub>PROT</sub> Overtemp OT	V <sub>PROT</sub> Short to Ground
			Reset	(0)	(1)	(0)	(0)	(0)	(0)	(0)	(0)

Table 27. Power supply and any system fault status register field description

Field	Description
2-V <sub>PROT</sub> Short to Battery	V <sub>PROT</sub> Short to Battery Status: 0-No Fault reported 1-Fault reported
1-V <sub>PROT</sub> Overtemp OT	V <sub>PROT</sub> Overtemp: 0-No Fault reported 1-Fault reported
0-V <sub>PROT</sub> Short to Ground	V <sub>PROT</sub> Short To Ground: 0-No Fault reported 1-Fault reported

## 5.5 Drivers blocks

### 5.5.1 Pin description

#### 5.5.1.1 INJIN1 input

The INJIN1 pin is the parallel input controlling the Injector output, INJOUT1. The INJIN1 pin is a 5.0 V logic level input with a built-in pull-down to ground that prevents accidental actuation of an injector if the connection to the pin is lost.

#### 5.5.1.2 RIN1, RIN2 inputs

The RIN1 and RIN2 pins are the parallel inputs controlling the relay outputs ROUT1 and ROUT2 respectively. The RIN1 and RIN2 pins are 5.0 V logic level inputs with built-in pull-downs to ground to prevent accidental actuation of a relay if the connection to the pin is lost.

#### 5.5.1.3 INJOUT1 driver output

This is an output pin for the INJOUT1 low-side driver. This output can be used as an injector driver output. Injector output is forced off during all RESET events.

#### 5.5.1.4 ROUT1, ROUT2 driver outputs

These are output pins for ROUT1 and ROUT2 low-side drivers and have different current ratings and can be used to drive relays (like fuel pump, main power relay, ...) or other inductive loads.

#### 5.5.1.5 LAMPOUT driver output

The Lamp driver output, LAMPOUT is a low-side driver capable of driving an incandescent lamp even under cold filament conditions and can also be used to drive a LED if the open load feature is disabled.

#### 5.5.1.6 Tachometer (TACHOUT)

The TACHOUT pin is a low-side driver which can be used to drive a tachometer meter movement and can be programmed via the SPI to:

- Output the same signal as VRSOUT divided by a 1 to 32 programmable divider
- Output a PWM signal with a frequency and duty cycle programmable via the SPI
- Output one of eight fixed frequencies

### 5.5.2 Common functionality

The six open drain low-side drivers (LSDs) are designed to control various automotive loads, such as injectors, fuel pumps, solenoids, lamps and relays, etc. Each driver includes off-state open load detection, on-state short-to-ground detection, short-circuit to battery protection, overcurrent protection, overtemperature protection and diagnostic fault reporting via the SPI. The LSD outputs can be Pulse Width Modulated (PWM'd) based on an internal and/or external frequency for use as variable speed motor drivers, LED/lamp dimming drivers, or as a fuel pump driver.

All outputs except ROUT2 are disabled when the KEYSW input pin is brought low regardless of the state of the input pins. All outputs, including ROUT2 are disabled when the RESETB pin is low.

#### 5.5.2.1 LSD input logic control

The three LSDs (INJOUT1, ROUT1 and ROUT2) are controlled individually using a combination of the external pin input (respectively INJIN1, RIN1 and RIN2) and/or a SPI On/Off Control bit. The two LSDs (LAMPOUT and TACHOUT) are controlled individually using a SPI On/Off Control bit. The logic can be made to turn the outputs on or off by:

- a logical combination of the external pin **OR**ed with the SPI Control On/Off Bit (Default State)
- a logical combination of the external pin **AND**ed with the SPI Control On/Off Bit

A separate OR/AND select bit is found in the SPI configuration registers to accomplish this selection.

## 5.5.2.2 Pulse Width Modulation mode

Alongside just turning the outputs ON or OFF, the six LSD outputs can be Pulse Width Modulated (PWM'd) to control the outputs with a variable 0 to 100% duty cycle at a selection of different frequencies. There are two built-in PWM frequencies (100 Hz and 1.0 kHz) and the external input pin can also be used as either an external PWM frequency input (divided by 100) or a total PWM (frequency and duty cycle) input.

Two bits (Bits 1, 0) in the SPI configuration register control which mode of input control is selected. The internal PWM duty cycles (D/C) are controlled by the lower seven bits in the corresponding SPI control register with a 1% increment. The external PWM duty cycles (D/C) are provided by the MCU on the input pin of the corresponding output driver.

## 5.5.2.3 Overcurrent (OC) protection

Output protection uses two strategies—overcurrent (OC) protection and/or overtemperature (OT) protection—to detect a fault. When a fault occurs, the output protection feature automatically controls the output to prevent damage to the output device.

The overcurrent protection scheme senses an overcurrent condition by monitoring the voltage on the individual output device drain.

### 5.5.2.3.1 Inrush delay

The Inrush Delay bit in the SPI Configuration Register for each output, when set to a one(1), prevents the overcurrent fault bit from being set and the overcurrent protection from shutting off the output for  $t_{\text{INRUSH}}$  time (Typ. 10 ms) rather than  $t_{\text{SC1}}$  (Typ. 60  $\mu\text{s}$ ).

This means that during this fixed time period, the device enters into current limitation, and the output is switched off when the fixed period expires.

Note that for the Lampout Driver, the default state is Inrush Delay equal to 1 ( $t_{\text{INRUSH}}$ ).

### 5.5.2.3.2 Retry feature

When the Retry feature is enabled (Retry Bit for each output) during an overcurrent condition at the end of the Inrush period, the output device turns off and waits until a delay time ( $t_{\text{Ref}}$ ) has passed. After this off time, the output tries to turn on again. If the short is still present, the process starts again. This on/off cycling continues until the output is shut off by command or the overtemperature (OT) on the output device is reached. Note that the Inrush delay resets to its default state for this on/off cycling. See [Figure 16](#).

If the SPI configuration register retry enable bit is set to a zero (0), this on/off cycling does not occur and the output turns off if the overcurrent threshold is reached. The output does not turn on again until the output is shut off and then on again by command.

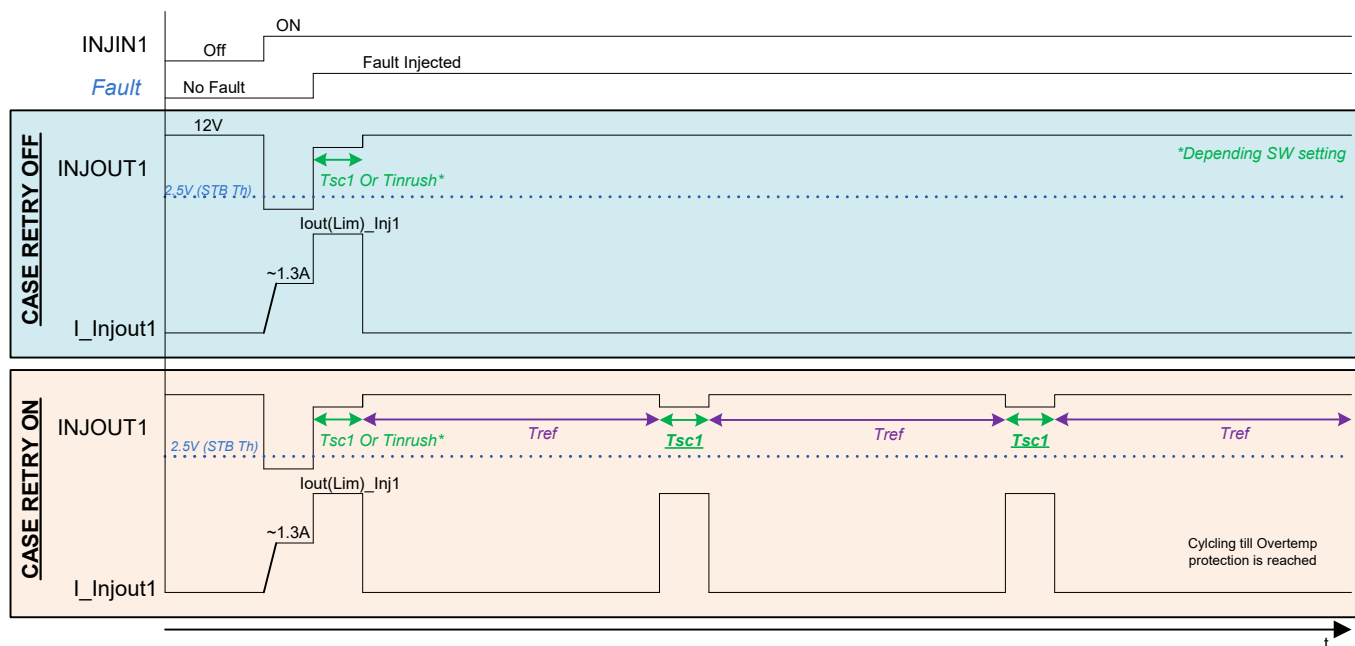

Figure 16. Retry and Inrush feature

## 5.5.2.4 Temperature limit (OT) protection

The second output protection scheme works by sensing the local temperature of the individual output device. During an overcurrent event, the device enters the current limit and remains there until the output driver maximum temperature limit is exceeded (OT). At this point, the device shuts down automatically regardless of the input state. The output tries to turn on again only when the junction temperature falls below the maximum temperature minus the  $T_{LIM}$  hysteresis temperature value and the input state is commanding the output to be on. The  $T_{LIM}$  hysteresis value is specified in the static parameter table.

The temperature limit ( $T_{LIM}$ ) protection is independent of the overcurrent protection and is not controlled by the SPI.  $T_{LIM}$  is always enabled and is always a retry operation. Outputs may be used in parallel to drive higher current loads as long as the turn-off energy of the load does not exceed the energy rating of a single output driver.

## 5.5.2.5 Open load (OL) and short-to-battery (OC) strategy

The injector, lamps, relays, and tachometer low-side outputs are capable of detecting an open load in the off state and short-to-battery condition in the on state. All faults are reported through the SPI status register communication (OL bit for open load fault and OC bit for short-to-battery fault).

For open load detection, a current source is placed between the MOSFET drain pin and the ground of the IC. An open load fault is reported when the drain voltage is less than the listed threshold. A shorted load fault is reported if the drain pin voltage is greater than the programmed short threshold voltage when the device is in the on state. The open load and short-to-battery fault threshold voltage is fixed and cannot be modified via the SPI.

The open load feature could be disabled (to allow the outputs to be used as LED drivers) by clearing the appropriate bit in the in the LSD configuration register.

## 5.5.2.6 Short-to-ground (SG) strategy

The injectors, lamps and relays (but not the Tachometer) low-side driver outputs are capable of detecting a short-to-ground by measuring the current flow in the output device and comparing it to a known current value. If a short-to-ground is detected, it is annunciated via a bit in the appropriate SPI status register.

## 5.5.2.7 Output driver diagnostics

Overcurrent (OC), temperature limit (OT) exceeded, short-to-ground (SG) and open load (OL) conditions are reported through the status register for each driver (no SG for the tachometer). A bit in the SPI status register indicates when any of the LSDs or pre-drivers are reporting a fault and when a particular output has any of the four possible fault conditions present. The MCU polls for fault conditions by looking for a single bit in one register to detect the presence of any fault in the circuit.

## 5.5.3 Special features

### 5.5.3.1 LAMP OUT

The Inrush delay bit is set to 1 by default to allow the driver to handle the inrush current of a cold lamp filament. It waits an additional time before annunciating an overcurrent condition. A pull-down current sink is provided to allow the IC to detect when the bulb is burned out (open filament). The LAMP is switched on and off via the SPI ON/OFF Control register word. It also has the ability to be PWM'd for advanced diagnostic (dimming) purposes via the SPI Lamp Control register. The output can also drive an LED if the open load detect current sink is commanded off via the SPI to prevent 'ghosting'.

## 5.5.3.2 TACHOUT

The TACHOUT pin is a low-side driver used to drive a tachometer meter movement. TACHOUT can be programmed via the SPI to:

- Output the same signal as VRSOUT divided by a 1 to 32 programmable divider
- Output a PWM signal with a frequency and duty cycle programmable via the SPI
- Output one of eight fixed frequencies, as indicated in [Table 30](#)

If a tachometer is not required, the TACHOUT output can also be used as a low current, SPI controlled, low-side driver to drive an LED or other low current load. The SPI Configuration register for the tachometer is used to determine for which mode this output is used. The TACHOUT output handles overcurrent (OC) differently than the other low-side drivers. When an overcurrent limit is reached, the TACHOUT output does not enter a current limiting state, but rather shuts the output off to protect the output device. The retry option works similarly to the other low-side drivers. In the LSD mode, bit 4 of the SPI Configuration register controls the turn on or turn off of the open load detect current sink.

## 5.5.3.3 Using ROUT2 as a power relay

The ROUT2 (Relay 2 Output) can be used to drive a power relay. The RIN2 input or the RIN2 bit in the SPI Control register can be used to turn the ROUT2 output on or off as desired. The BATSW output can be connected to the RIN2 input to control the power relay, or the MCU can choose to control the RIN2 bit in the SPI Control register to actuate the power relay. The ROUT2 output is unique in that it can be kept turned on even after KEYSW is turned off (as long as the PWREN bit is still set to a one), by setting the shutdown disable (SDD) bit in the ROUT2 Configuration register.

## 5.5.4 SPI drivers registers

### 5.5.4.1 SPI configuration registers

**Table 28. Injector 1/2, Relay1/2,Lampout configuration registers**

Reg #	Hex		7	6	5	4	3	2	1	0
0	0	Injector 1 Driver	Retry Enable	X	X	OL Current Sink Enable	In-Rush Delay	OR/AND	PWM Freq. 1	PWM Freq. 0
			Reset	(0)	(0)	(0)	(1)	(0)	(0)	(0)
1	1	Not Used	Retry Enable	X	X	X	X	X	X	X
			Reset	(0)	(0)	(0)	(0)	(0)	(0)	(0)
2	2	Relay 1 Driver	Retry Enable	X	X	OL Current Sink Enable	In-Rush Delay	OR/AND	PWM Freq. 1	PWM Freq. 0
			Reset	(0)	(0)	(0)	(1)	(0)	(0)	(0)
3	3	Relay 2 Driver	Retry Enable	Shutdown DisableSD D	X	OL Current Sink Enable	In-Rush Delay	OR/AND	PWM Freq. 1	PWM Freq. 0
			Reset	(0)	(0)	(0)	(1)	(0)	(0)	(0)
5	5	Lamp Driver	Retry Enable	X	X	OL Current Sink Enable	In-Rush Delay	X	PWM Freq. 1	PWM Freq. 0
			Reset	(0)	(0)	(0)	(1)	(1)	(0)	(0)

**Table 29. Injector 1 and Relay 1/2 Lampout configuration. Field description**

Field	Description
7-Retry Enable	Retry Enable 0-Disable 1-Enable
6-Shutdown Disable SDD	Shutdown Disable mode selection <sup>(22)</sup> allowing to keep ROUT2 ON even after KEYSW =0 0- SDD mode disable 1- SDD mode enable

**Table 29. Injector 1 and Relay 1/2 Lampout configuration. Field description**

Field	Description
4-OL Current Sink Enable	Open Load Current Sink Enable 0- Disable (OL Flag in status register will be forced to 0) 1- Enable (Default)
3-In-Rush Delay	In-rush Delay Time disabling overcurrent protection 0- $t_{SC1}$ (Default) 1- $t_{INRUSH}$ <sup>(23)</sup>
2-OR/AND	OR/AND logical action to control LS Output <sup>(24)</sup> 0- OR between Input pin and Control bit (Default) 1-AND between Input pin and Control bit
1/0- PWM Freq1/0	PWM Frequency and Duty Cycle mode <sup>(25)</sup> 00-PWM Freq.: None or Ext.Pin - D/C: None or ext.Pin 01-PWM Freq.:100 HZ-D/C: Internal 10-PWM Freq.: 1 KHZ-D/C: Internal 11-PWM Freq.:On ext. pin /100 -D/C: Internal

Notes

- 22. Valid only for Relay 2 Driver.
- 23. Default For Lampout Driver
- 24. NA for Lampout Driver
- 25. No ext Pin for Lampout Driver

**Table 30. Tachometer driver configuration registers**

Reg #	Hex			7	6	5	4	3	2	1	0
4	4	Tachometer Driver		Retry Enable	Vrsout/ LSD	Vrsout/ Osc. mode	N16/OL Current Sink Enable	N8/In-Rush Delay	N4/Osc 2	N2/Osc 1/ PWM Freq. 1	N1/Osc 0/ PWM Freq. 0
			Reset	(0)	(0)	(0)	(0)	(0)	(0)	(0)	(1)

**Table 31. Tachometer driver configuration registers. Field description**

Field	Description
7-Retry Enable	Retry Enable 0-Disable 1-Enable
6- $V_{RSOUT}$ /LSD 5- $V_{RSOUT}$ / Osc.mode	VRSOUT/LSD/OSC mode selection 00 (Default) - VRSOUT Output divided by N 01- Oscillator Output 10- Low-side Driver mode 11- Same as 10 (LSD)
4-N16/ OL Current Sink Enable	N16 or Open Load Current Sink Enable -When used as VRSOUT, see <a href="#">Table 32</a> . -When used as LSD: 0- Disable (Open Load Flag in status register will be forced to 0) 1- Enable (Default)
3-N8/In-Rush Delay	N8 / In-Rush Delay Time disabling overcurrent protection -When used as VRSOUT, see <a href="#">Table 32</a> . -When used as LSD: 0- $t_{SC1}$ 1- $t_{INRUSH}$
2-1-0:N(4,2,1), Osc (2,1,0) PWM freq (x,1,0)	N(4,2,1) or Output Frequency or PWM Output -When used as VRSOUT, see <a href="#">Table 32</a> . -When used as Oscillator Output, see <a href="#">Table 33</a> -When used as PWM output, see <a href="#">Table 34</a>

**Table 32. Tachout mode configuration when used as VSROUT**

SPI Configuration Register Bits 4, 3, 2, 1, 0 (N16, N8, N4, N2, N1)	TACHOUT mode VRSOUT divided by 'N' where 'N' is defined by bits 0 thru 4 of SPI
00000	N=32
00001 (default)	N=1
00010	N=2
.....	.....
11111	N=31

**Table 33. Fixed oscillator frequencies configuration when used as an oscillator output**

SPI Configuration Register Bits 2,1,0 (Osc2, Osc1, Osc0)	Oscillator Frequencies mode
000	10 Hz
001 (default)	100 Hz
010	1.0 kHz
011	5.0 kHz
100	10 kHz
101	20 kHz
110	40 kHz
111	100 kHz (not recommended for use)

**Table 34. PWM frequency configuration when used as LSD**

SPI Configuration Register Bits 1, 0 PWM Frequency	PWM mode
x00	None
x01 (default)	PWM Freq: 100 Hz - D/C: Internal
x10	PWM Freq: 1.0 kHz - D/C: Internal
x11	None

## 5.5.4.2 SPI control registers

**Table 35. Main OFF/ON control register**

Reg #	Hex		7	6	5	4	3	2	1	0
0	0	Main OFF/ON Control	INJ1	X	REL1	REL2	LAMP	IGN1	X	O2H
		Reset	(0)	(0)	(0)	(0)	(0)	(0)	(0)	(0)

**Table 36. Main OFF/ON control register field description**

Field	Description
7-INJ1	INJOUT1 Bit Control 0-OFF 1-ON
5-REL1	ROUT1 Bit Control 0-OFF 1-ON
4-REL2	ROUT2 Bit Control 0-OFF 1-ON
1-LAMP	LAMP Bit Control 0-OFF 1-ON

**Table 37. Other OFF/ON control register**

Reg #	Hex			7	6	5	4	3	2	1	0
1	1	Other OFF/ON Control		Pwren OFF/ON	POST Enable OFF/ON	X	VProt ON/OFF	X	Batsw OFF/ON	Tach OFF/ON	RESET internal only
			Reset	(0)	(0)	(0)	(1)	(0)	(0)	(1)	(0)

**Table 38. Other OFF/ON control register field description**

Field	Description
1-Tach OFF/ON	TACHOUT Bit Control 0-OFF 1-ON

**Table 39. PWM duty cycle setting control register**

Reg #	Hex			7	6	5	4	3	2	1	0
2	2	Injector 1 Driver		X	PWM6	PWM5	PWM4	PWM3	PWM2	PWM1	PWM0
			Reset	(0)	(0)	(0)	(0)	(0)	(0)	(0)	(0)
3	3	Not Used		X	X	X	X	X	X	X	X
			Reset	(0)	(0)	(0)	(0)	(0)	(0)	(0)	(0)
4	4	Relay 1 Driver		X	PWM6	PWM5	PWM4	PWM3	PWM2	PWM1	PWM0
			Reset	(0)	(0)	(0)	(0)	(0)	(0)	(0)	(0)
5	5	Relay 2 Driver		X	PWM6	PWM5	PWM4	PWM3	PWM2	PWM1	PWM0
			Reset	(0)	(0)	(0)	(0)	(0)	(0)	(0)	(0)
6	6	Tachometer Driver		X	PWM6	PWM5	PWM4	PWM3	PWM2	PWM1	PWM0
			Reset	(0)	(0)	(0)	(0)	(0)	(0)	(0)	(0)
7	7	Lamp Driver		X	PWM6	PWM5	PWM4	PWM3	PWM2	PWM1	PWM0
			Reset	(0)	(0)	(0)	(0)	(0)	(0)	(0)	(0)

**Table 40. PWM duty cycle setting control register field description**

Field	Description
6-0 -PWMx	PWM Duty Cycle Setting with 1% increment 0000000 to 1100100 (Dec. 100) represent 0% to 100% 1100100(Dec. 100) to 1111111 (Dec.127) all map to 100%.



### 5.5.4.3 SPI status registers

Table 41. LS driver status register

Reg #	Hex		7	6	5	4	3	2	1	0
0	0	Injector 1 Driver Faults	Faults	X	X	X	Open Load OL	Over - current OC	Overtemp OT	Short Gnd SG
			Reset	(0)	(0)	(0)	(0)	(0)	(0)	(0)
1	1	Not Used	X	X	X	X	X	X	X	X
			Reset	(0)	(0)	(0)	(0)	(0)	(0)	(0)
2	2	Relay 1 Driver Faults	Faults	X	X	X	Open Load OL	Overcurrent OC	Overtemp OT	Short Gnd SG
			Reset	(0)	(0)	(0)	(0)	(0)	(0)	(0)
3	3	Relay 2 Driver Faults	Faults	X	X	X	Open Load OL	Overcurrent OC	Overtemp OT	Short Gnd SG
			Reset	(0)	(0)	(0)	(0)	(0)	(0)	(0)
4	4	Tachometer Driver Faults	Faults	X	X	X	Open Load OL	Overcurrent OC	Overtemp OT	X
			Reset	(0)	(0)	(0)	(0)	(0)	(0)	(0)
5	5	Lamp Driver Faults	Faults	X	X	X	Open Load OL	Overcurrent OC	Overtemp OT	Short Gnd SG
			Reset	(0)	(0)	(0)	(0)	(0)	(0)	(0)

Table 42. LS driver status register description field

Field	Description
7-Faults	Global Driver Fault bit (by driver) Logical OR of bit 0-3 0-No Fault 1-Fault detected
3-Open Load OL	Open Load Fault Flag 0-No Fault (Forced to 0 if OL feature disabled) 1-Fault detected
2-Overcurrent OC	Overcurrent Fault Flag 0-No Fault 1-Fault detected
1-Over Temp OT	Over Temp Limit Fault Flag 0-No Fault 1-Fault detected
0-Short GND SG	Over Temp Limit Fault Flag <sup>(26)</sup> 0-No Fault 1-Fault detected

Notes

26. Not present on Tachometer Driver

Table 43. System On/Off indicators status register

Reg #	Hex		7	6	5	4	3	2	1	0
14	E	System On/Off Indicators	INJ1 Off/On	X	REL1 Off/On	REL2 Off/On	LAMP Off/On	IGN1 Off/On	X	O2H Off/On
			Reset	(0)	(0)	(0)	(0)	(0)	(0)	(0)

**Table 44. System On/Off indicators status register field description**

Field	Description
7-3 Driver Off/On	Driver On/Off Status 0- Off 1- On

## 5.6 Pre-driver

### 5.6.1 Pin description

#### 5.6.1.1 IGNIN1 input

The IGNIN1 pin is the parallel input controlling the IGNOUT1 pre-driver output. The IGNIN1 pin is a 5.0 V logic level inputs with built-in pull-downs to ground that prevents accidental actuation of a pre-driver output if the connection to the pin is lost.

#### 5.6.1.2 O2HIN input

The O2HIN pin is the parallel input controlling the O2HOUT pre-driver output. The O2HIN pin is a 5.0 V logic level input with a built-in pull-down to ground that prevents accidental actuation of the pre-driver output if the connection to the pin is lost.

#### 5.6.1.3 IGNOUT1 Pre-driver output with feedback IGNFB1 and current sense inputs IGNSENSP and IGNSENSN

The IGNOUT1 output is a pre-driver output driving either an ignition (IGBT) pre-driver or a general purpose gate driver (GPGD). INGOUT1 is configured by default as an IGBT driver to control the ignition coil current to produce a spark.

The IGNOUT1 output and its associated feedback pin IGNFB1 provides one short-to-battery and one current sense resistor provides overcurrent protection for the external driver transistor. When used as an IGBT driver, a 10:1 voltage divider (9R:1R) must be used on the feedback pins to prevent the 400 V flyback from damaging the IC. More accurate current control can be provided by placing a current sense resistor between the IGNSENSP and IGNSENSN pins.

#### 5.6.1.4 O2HOUT Pre-driver output with drain feedback input O2HFB and current sense inputs O2HSENSP and O2HSENSN

The O2HOUT output is a pre-driver output driving either an ignition (IGBT) pre-driver or a general purpose gate driver (GPGD). O2HOUT is configured by default as GPDC to control the gate of a MOSFET to drive a heater on an O2 (Lamda) sensor. The pre-driver is capable of driving most power MOSFETs. The O2HOUT output and associated drain feedback pin O2HFB provide short-to-battery, overcurrent protection for the external driver MOSFET. When used as an IGBT driver, a 10:1 voltage divider (9R:1R) must be used on the feedback pins to prevent the 400 V flyback from damaging the IC. More accurate current control can be provided by placing a current sense resistor between the O2HSENSP and O2HSENSN pins.

## 5.6.2 Functions description

There are two identical pre-drivers in the 33813. Each pre-driver can be configured as either an ignition (IGBT) pre-driver or a general purpose gate driver (GPGD). By default, one pre-driver is configured as a GPGD (O2HOUT) and one pre-driver is configured as an ignition (IGNOUT1) pre-driver. A bit in each pre-driver's SPI Configuration register defines whether the pre-driver behaves as an ignition or a GPGD pre-driver.

Each pre-driver includes off-state open load detection and can be Pulse Width Modulated (PWM'd) based on an internal and/or external frequency for use as variable speed motor drivers, LED/lamp dimming drivers, or as a fuel pump driver.

### 5.6.2.1 Pre-driver input logic control

The two Pre-drivers (IGNOUT1 and O2HOUT) are controlled individually using a combination of the external pin input (respectively IGNIN1 and O2HIN) and/or a SPI On/Off Control bit.

The logic can be made to turn the outputs on or off by:

- a logical combination of the external pin **OR**ed with the SPI Control On/Off Bit (Default State)
- a logical combination of the external pin **AND**ed with the SPI Control On/Off Bit

A separate OR/AND select bit is found in the SPI configuration registers to accomplish this selection.

### 5.6.2.2 Pulse Width Modulation mode

See [5.5.2.2. Pulse Width Modulation mode, page 35](#).

### 5.6.2.3 Open load (OL) and short-to-battery (OC) strategy

The Pre-drivers are capable of detecting an open load in the off state and short-to-battery condition in the on state. All faults are reported through the SPI status register communication (OL bit for open load fault and OC bit for short-to-battery fault).

For open load detection, a current source is placed between the MOSFET drain pin and ground of the IC. An open load fault is reported when the drain voltage is less than the specified threshold. A shorted load fault is reported when the drain pin voltage is greater than the programmed short threshold voltage when the device is in the on state. The open load and short-to-battery fault threshold voltage is fixed and cannot be modified via the SPI.

The Open Load feature could be disabled (current source disable) by clearing the appropriate bit in the in the pre-driver configuration register.

### 5.6.2.4 Current sense protection (OC) strategy

Two current measurement circuits, ISGNSP/N and O2HSP/N, are available for more accurate current control and better protection of pre-driver. A current sense resistor should be place between the IGNSP and IGNSN pins for IGNOUT1 and between O2HSENSEP and O2HSENSEN for O2HOUT.

The input controls determine the value of the current sense threshold voltage across the current sense resistor ( $V_{SENS\_Th}$ ).

### 5.6.2.5 Inrush delay

See [5.5.2.3.1. Inrush delay, page 35](#).

### 5.6.2.6 Output pre-driver diagnostics.

Overcurrent (OC) and open load (OL) conditions are reported through the status register for each pre-driver. There is also a bit in the SPI status register to indicate when any of the pre-drivers report a fault and when a particular output has any of the four possible fault conditions present. The MCU polls for fault conditions by looking for a single bit in one register to detect the presence of any fault in the circuit.

## 5.6.3 SPI drivers registers

### 5.6.3.1 SPI configuration registers

Table 45. Pre-driver configuration registers

Reg #	Hex			7	6	5	4	3	2	1	0
7	7	O2 Heater Pre-driver		GPGD/IGN Select	Retry Enable	X	OL Current Sink	X	OR/AND	PWM Freq. 1	PWM Freq. 0
			Reset	(0)	(0)	(0)	(1)	(0)	(0)	(0)	(0)
8	8	Ignition 1 Pre-driver		GPGD/IGN Select	Retry Enable	X	OL Current Sink	X	OR/AND	PWM Freq. 1	PWM Freq. 0
			Reset	(1)	(0)	(0)	(0)	(0)	(0)	(0)	(0)

Table 46. Pre-driver configuration registers field description

Field	Description
7-GPGD/IGN	GPGD/IGN mode selection 0- General Purpose Gate Driver (Default for O2HOUT) 1-IGBT Driver (Default for IGNOUT1)
6-Retry Enable	Retry Enable 0-Disable 1-Enable
4-OL Current Sink	Open Load Current Sink Enable 0- Disable (Open Load Flag in status register will be forced to 0) 1- Enable (Default for O2Heater Pre-driver)
2-OR/AND	OR/AND logical action to control Output 0- OR between Input pin and Control bit (Default) 1-AND between Input pin and Control bit
1/0 -PWM Freq1/0.	PWM Frequency and Duty Cycle mode 00-PWM Freq.: None or Ext.Pin - D/C: None or ext.Pin 01-PWM Freq.:100 HZ-D/C: Internal 10-PWM Freq.: 1 kHz-D/C: Internal 01-PWM Freq.:On ext. pin /100 -D/C: Internal

### 5.6.3.2 SPI control registers

Table 47. Main OFF/ON control register

Reg #	Hex			7	6	5	4	3	2	1	0
0	0	Main OFF/ON Control		INJ1	X	REL1	REL2	LAMP	IGN1	X	O2H
			Reset	(0)	(0)	(0)	(0)	(0)	(0)	(0)	(0)

Table 48. Main OFF/ON control register field description

Field	Description
2-IGN1	IGN1 Bit Control 0-OFF 1-ON
0-O2H	O2H Bit Control 0-OFF 1-ON

**Table 49. PWM D/C configuration register**

Reg #	Hex			7	6	5	4	3	2	1	0
9	9	O2 Heater Pre-driver		X	PWM6	PWM5	PWM4	PWM3	PWM2	PWM1	PWM0
			Reset	(0)	(0)	(0)	(0)	(0)	(0)	(0)	(0)
10	A	Ignition 1 Pre-driver		X	PWM6	PWM5	PWM4	PWM3	PWM2	PWM1	PWM0
			Reset	(0)	(0)	(0)	(0)	(0)	(0)	(0)	(0)

**Table 50. PWM D/C configuration register field description**

Field	Description
6-0 -PWMx	PWM Duty Cycle Setting with 1% increment 0000000 to 1100100 (Dec. 100) represent 0% to 100% 1100100(Dec. 100) to 1111111 (Dec.127) all map to 100%.

### 5.6.3.3 SPI status registers

**Table 51. Pre-driver status registers**

Reg #	Hex			7	6	5	4	3	2	1	0
7	7	O2 Heater Pre-driver Faults		Faults	X	X	X	Open Load OL	Overcurrent OC	X	X
			Reset	(0)	(0)	(0)	(0)	(0)	(0)	(0)	(0)
8	8	Ignition 1 Pre-driver Faults		Faults	X	X	X	Open Load OL	Overcurrent OC	X	X
			Reset	(0)	(0)	(0)	(0)	(0)	(0)	(0)	(0)

**Table 52. Pre-driver status registers field description**

Field	Description
7-Faults	Global Driver Fault bit (by driver) Logical OR of bit 3-2 0-No Fault 1-Fault detected
3-Open Load OL	Open Load Fault Flag 0-No Fault (Forced to 0 if OL feature disabled) 1-Fault detected
2-Overcurrent OC	Overcurrent Fault Flag (including Short To V <sub>BAT</sub> Fault) 0-No Fault 1-Fault detected

**Table 53. System On/Off indicators status register**

Reg #	Hex			7	6	5	4	3	2	1	0
14	E	System On/Off Indicators		INJ1 Off/On	X	REL1 Off/On	REL2 Off/On	LAMP Off/On	IGN1 Off/On	X	O2H Off/On
			Reset	(0)	(0)	(0)	(0)	(0)	(0)	(0)	(0)

**Table 54. System On/Off indicators status register field description**

Field	Description
2-0 xxx Off/On	Pre-driver On/Off Status 0- Off 1- On

## 5.7 VRS circuitry

### 5.7.1 PIN Description

#### 5.7.1.1 VRSP and VRSN inputs

The VRSP and VRSN form a differential input for the Variable Reluctance Sensor attached to the crankshaft toothed wheel. It is important to provide an external 15 k $\Omega$  current limiting resistors to prevent damage to the VRSP and VRSN inputs (See [Figure 17](#)). The VRS can be connected to the 33813 in either a differential or single-ended fashion. The use of a differential filtering capacitor and grounded capacitors of at least 100 nF are also advisable. In some applications, placing a damping resistor of approximately 5.0 k $\Omega$  directly across the pickup coil is also useful to minimize high frequency ringing.

#### 5.7.1.2 VRSOUT output

The VRSOUT Pin is the output of the VRS circuit, which is a 5.0 Volt logic level signal provided to the MCU.

## 5.7.2 Functions description

The 33813 contains a VRS input conditioning circuit employing a differential input. VRSP and VRSN are the positive and negative inputs from the VRS (See [Figure 17](#)). An internal zener diode clamps to ground and  $V_{CC}$  limits the input voltage to within the safe operating range of the circuit.

The VRS circuit conditions and digitizes the input from the crankshaft mounted toothed wheel to provide an angle clock and RPM data to the MCU. This circuit provides a comparator with multiple thresholds programmed via the SPI. This allows the VRS circuit to handle different sensors and a dynamic range of VRS output at engine speeds ranging from cranking to running. The output of this circuit is provided on the VRSOUT pin to the MCU. The comparator threshold values can also be controlled automatically based on the input signal amplitude.

The output of the comparator contains a programmable one shot, noise blanking circuit. The time value of this blanking pulse can be selected via the SPI as a percentage of the last input high (or low) pulse. The VRSOUT output can also be divided and sent to the TACHOUT pin to drive a tachometer.

Two different SPI registers are provided to control the VRS circuit values in the manual mode. The SPI VRS configuration register is used to set the 'engine running' values for the threshold and blanking filter, and the SPI VRS control register is used to provide the 'engine cranking' threshold and blanking filter values. Once the engine is running, the MCU clears the SPI VRS control register (engine cranking) and the 33813 uses the values found in the SPI VRS configuration register (engine running).

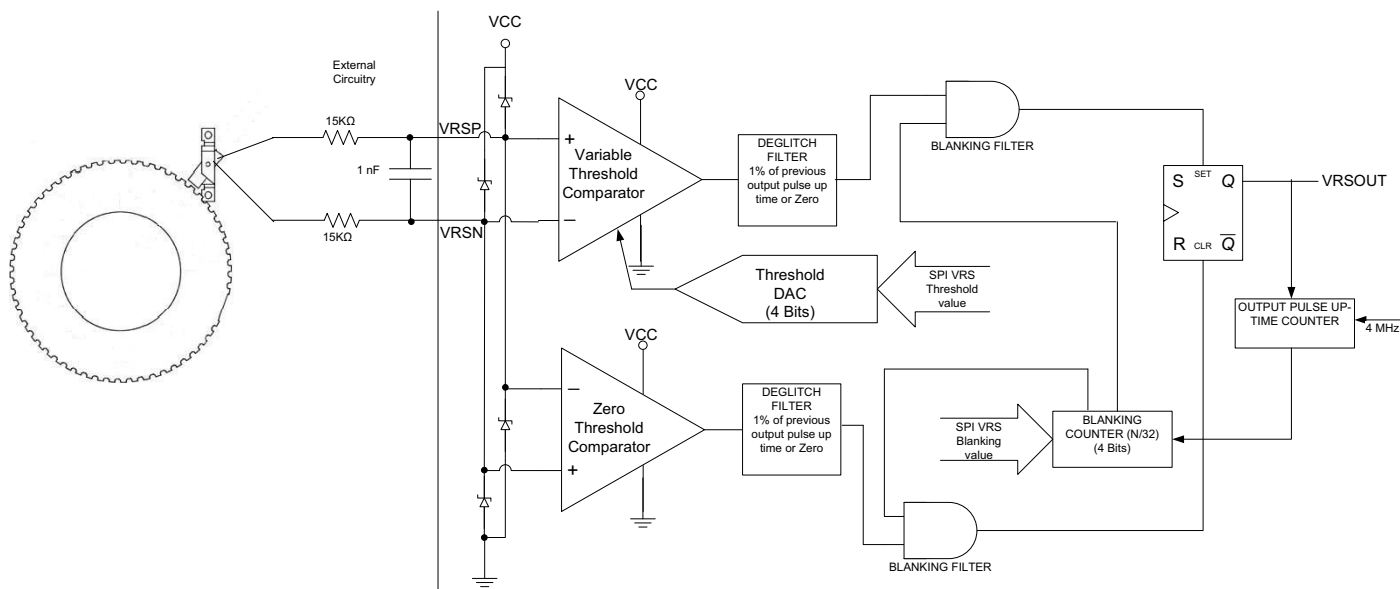

Figure 17. VRS schematic

### 5.7.2.1 'Engine Running' and 'Engine Cranking' parameters

Two different SPI registers are provided to define two different sets of parameters (Input Threshold and Blanking Time) for 'engine running' and 'engine cranking' conditions, in the manual mode. The SPI VRS Engine Running Parameters register is used to set the 'engine running' values for the threshold and blanking filter. The SPI VRS Engine Cranking Parameters register is used to set the 'engine cranking' values for the threshold and blanking filter.

When the contents of the SPI VRS Engine Cranking Parameters register contains all zeros, the value for parameters is taken from the value in the SPI VRS Engine Running Parameters register.

When the contents of the SPI VRS Engine Cranking Parameters register is non-zero, the value for parameters is taken from this register. So from system point of view, once the engine is running, the MCU should clear the SPI VRS Engine Cranking Parameters register and the 33813 uses the values found in the SPI VRS Engine Running Parameters.

#### 5.7.2.1.1 Input comparator threshold values

The threshold voltage for the input comparator is produced by a 4-bit D/A converter. The SPI VRS Engine Cranking Parameters register or SPI VRS Engine Running Parameters register controls the output value of the D/A. The values output by this D/A, using one or the other register, are listed in the below threshold values table.

**Table 55. Input comparator threshold value table**

SPI VRS Manual Parameter Configuration Registers Bits 7, 6, 5, 4	Min. Threshold Value	Threshold Values (Nominal)	Max. Threshold Value	Comment
0000	—	10 mv	28 mv	Tolerance not specified, for information only. Monotonicity not guaranteed.
0001	—	14 mv	36 mv	
0010	3.0 mv	20 mv	38 mv	Tolerance not specified, for information only. Only specified for monotonicity.
0011	5.0 mv	28 mv	50 mv	
0100	21 mv	40 mv	55 mv	
0101 (default)	25 mv	56 mv	80 mv	
0110	56 mv	80 mv	92 mv	
0111	-20%	110 mv	+20%	Tolerance and monotonicity specified.
1000	-20%	150 mv	+20%	
1001	-20%	215 mv	+20%	
1010	-20%	300 mv	+20%	
1011	-20%	425 mv	+20%	
1100	-20%	600 mv	+20%	
1101	-20%	850 mv	+20%	
1110	-20%	1.21 V	+20%	
1111	-20%	1.715 V	+20%	

### 5.7.2.1.2 Blanking time definitions

The values for the one shot blanking as a percentage of the last high output pulse period is shown in [Table 56](#).

**Table 56. SPI VRS manual configuration register**

SPI VRS Configuration/Control Register Bits 3,2,1,0	Blanking Time in% (of last pulse high period)
0000 (default)	0.0
0001	3.12
0010	6.25
0011	9.37
0100	12.5
0101	15.62
0110	18.75
0111	21.87
1000	25
1001	28.1
1010	31.3
1011	34.4
1100	37.5
1101	40.6
1110	43.8
1111	46.9



## 5.7.2.2 Manual and Automatic modes

The SPI VRS miscellaneous configuration register has a bit to enable the automatic selection of the comparator threshold (bit 7). At this time, the operation of automatic mode remains.

Under cranking conditions in Manual mode, the selected threshold value is fixed (VT Selected) by the SPI VRS Engine Cranking Parameters register. To avoid invalid detection due to noise close to the selected threshold, Automatic mode allows the VRS system to be less sensitive to noise in the cranking mode.

As soon as the VRS Input signal crosses zero, the VRS system selects the highest Input Comparator Threshold (VT Max 1.715 V Typ.). A decay circuitry ensures the VRS system decays from VT Max to VT Selected with the correct timing. The setting of the decay timing is done through the SPI VRS Automatic Parameters Configuration Register.

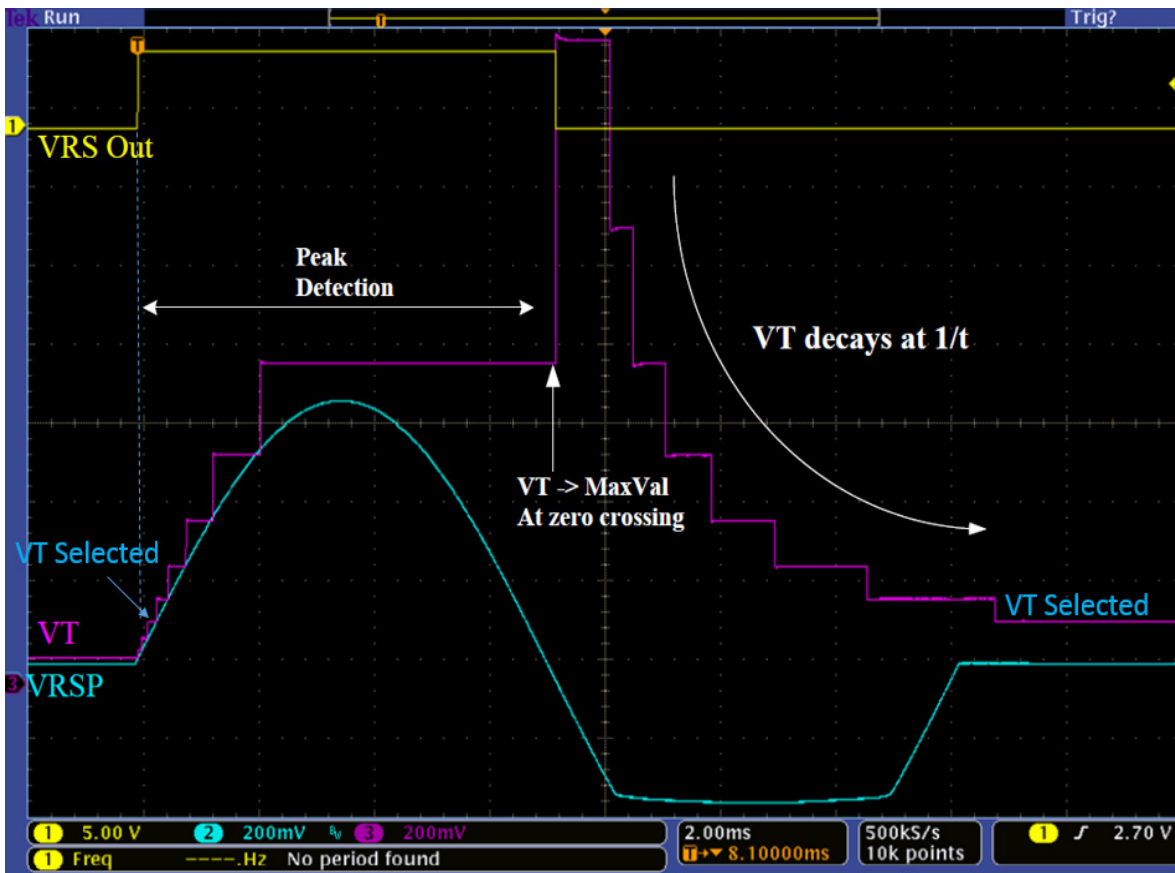

Figure 18. Automatic mode illustration (VT signal in pink is internal IC signal not observable in application)

Mantissa and Exponent parameters defined in the VRS Automatic mode parameters register set the decay time of the system.

The Mathematical formula is:

$$E = \log_2[(V_{\text{peak}} \times \text{Tau})/18.1] - 4 \text{ truncated}$$

$$M = \{[(V_{\text{peak}} \times \text{Tau})/18.1]/2^E\} - 16 \text{ rounded to nearest integer}$$

So Tau (timing between zero crossing and  $V_{\text{PEAK}}$ ) and the  $V_{\text{PEAK}}$  value are required to determine M and E parameters. Tau and  $V_{\text{PEAK}}$  could be calculated, based on system specification (number of teeth, minimum RPM,...). However, NXP recommends measuring physical parameters on the real application to define the best setting. A dedicated application note is available to explain the mathematical principle and measurement instructions.

### 5.7.2.3 Disable VRS bit

The disable VRS bit in the SPI VRS miscellaneous configuration register is used to disable the VRS input circuitry when there is no need for a VRS input conditioning circuit. This would be the case, for example, if the crankshaft wheel sensor was a hall effect device whose output could be directly input to the MCU. The default for this bit is zero (0) indicating the VRS input conditioning circuitry is active.

### 5.7.2.4 High/Low reference bit

The High/Low reference bit in the SPI VRS miscellaneous configuration register is used to change the use of the input high pulse timing to input low pulse timing, in cases where an elongated tooth wheel is being used rather than the missing tooth wheel. The default for this bit is zero (0), indicating the use of a crankshaft wheel with a missing tooth (or teeth).

### 5.7.2.5 VRS deglitching filters

The VRS input circuit has additional filters on the rising and falling edges of the input waveforms to reduce the effect of short transitions occurring during noise sensitive times. The deglitching filters are approximately 1% of the last positive pulse period. The deglitch filters are enabled by setting the deglitch bit (bit 3) in the SPI VRS miscellaneous parameters configuration register. This bit is, by default, zero (0), meaning the deglitch filters are disabled.

### 5.7.2.6 GND VRSN bit

To use the VRS inputs in a single-ended configuration, the “GND VRSN” bit in the SPI Configuration register must be set to indicate to the 33813 that this mode is being used. The VRS is then connected between the VRSP input and ground. The default for this bit is zero (0), indicating the differential mode is selected. Note that, in a single-ended configuration, the 2.5 V reference should be disconnected from the associated bit when using a Variable Reluctance Sensor.

Note that a hall effect sensor can be used instead of a VRS. To do so, the bits GND VRSN and disable 2.5 V ref must be 0 and the VRSN pin must not be connected. In this case, the voltage on VRSN is 2.5 V and the 0 crossing can be done even if low state output of the hall effect is 0 V or little higher.

### 5.7.2.7 Inverting inputs

The Inv. Inputs Bit in the SPI VRS Miscellaneous Parameter Register is used to make a logical inversion of all functions. This is swapping the VRSP and VRSN signals.

### 5.7.2.8 2.5 Volt reference disconnect bit

The disconnect 2.5 V reference bit in the SPI VRS configuration register is used to disconnect the internal 2.5 V reference signal from the VRSN and VRSP inputs so an external reference voltage can be employed. The default state of this bit is zero (0), indicating the internal 2.5 Volt reference voltage is connected to the VRSN and VRSP inputs.

### 5.7.2.9 VRS peak detector

The VRS peak detector determines the magnitude of the positive peak of the VRS input signal and digitizes it. The value of the VRS peak voltage is reported in the VRS SPI status register bits 7, 6, 5 and 4. The MCU reads the input pulse peak voltage value after the zero crossing time and uses this information to set the threshold and blanking parameters for subsequent input pulses. Status bits reflect the last detected peak and only read 0000 after a POR or SPI reset command.

**Table 57. Peak detector output in SPI VRS status register**

SPI VRS Status Register Bits 7,6,5,4	Peak Values (nominal)
0000	10 mV
0001	14 mV
0010	20 mV
0011	28 mV
0100	40 mV
0101	56 mV

**Table 57. Peak detector output in SPI VRS status register (continued)**

0110	80 mV
0111	110 mV
1000	150 mV
1001	215 mV
1010	300 mV
1011	425 mV
1100	600 mV
1101	850 mV
1110	1.210 V
1111	1.715 V

### 5.7.2.10 Clamp active status bits

There are two clamp active status bits in the SPI VRS status register. One is for the low pulse clamp and the other is for the high pulse clamp. When either of these bits are a one (1), it indicates the peak voltage for the part of the input waveform which has exceeded the clamp voltage and is clamped to the high or low voltage limit. These status bits can be used to indicate the engine has attained the speed necessary to switch from 'cranking' values for the threshold and blanking (in the SPI VRS control register) to the 'running' values (in the SPI VRS configuration register).

## 5.7.3 SPI drivers registers

### 5.7.3.1 SPI configuration registers

**Table 58. VRS configuration registers**

Reg #	Hex		7	6	5	4	3	2	1	0
11	B	VRS Engine Running Parameters	Threshold 3	Threshold 2	Threshold 1	Threshold 0	Filter Time 3	Filter Time 2	Filter Time 1	Filter Time 0
			Reset	(0)	(1)	(0)	(1)	(0)	(0)	(1)
12	C	VRS Automatic Parameters	mantiss 8	mantiss 4	mantiss 2	mantiss 1	exponent 8	exponent 4	exponent 2	exponent 1
			Reset	(0)	(0)	(1)	(0)	(0)	(0)	(0)
13	D	VRS Miscellaneous Parameters	Man./Auto	Disable VRS	X	High/Low Ref	De-glitch	Gnd VRSN	Inv Inputs	Disable 2.5 V CM
			Reset	(0)	(0)	(0)	(0)	(0)	(0)	(0)

**Table 59. VRS engine running parameters register field description**

Field	Description
7-4 Threshold x	Input Comparator Threshold Value Selection, <a href="#">Table 55</a>
3-0 Filter Time x	Blanking Time Selection, <a href="#">Table 56</a>

**Table 60. VRS automatic parameters register field**

Field	Description
7-5 Mantissa x	Mantissa parameter to set the decay timing in Automatic mode
3-0 Exponent x	Exponent parameter to set the decay timing in Automatic mode

**Table 61. VRS miscellaneous parameters register field**

Field	Description
7-MAN/Auto	Manual/Automatic mode selection 0-Manual mode (Default) 1-Automatic mode
6-Disable VRS	Disabling the VRS System 0- VRS Enable (Default) 1-VRS disable
4-High/Low Ref	High/Low reference 0-High Pulse Timing (Missing tooth Wheel) 1-Low Pulse Timing (Elongated Tooth Wheel)
3-De-glitch	Additional Deglitching Filter 0-De-glitch Disable 1-De-glitch enable
2-Gnd VRSN	Single Ended Configuration (VRSN = GND) or Differential mode configuration 0-Differential mode configuration 1-Single ended configuration
1-Inv inputs	Logical Inversion of all functions 0-VRSN and VRSP not swapped 1-VRSN and VRSP swapped
0-Disable 2.5V CM	Disable 2.5 V reference 0-Internal 2.5 V Ref connected to VRSN and VRSP 1-Internal 2.5 V Ref disconnected from VRSN and VRSP

### 5.7.3.2 SPI control registers

**Table 62. VRS engine cranking parameters register**

Reg #	Hex			7	6	5	4	3	2	1	0
13	D	VRS Engine Cranking Parameters		Threshold 3	Threshold 2	Threshold 1	Threshold 0	Filter Time 3	Filter Time 2	Filter Time 1	Filter Time 0
			Reset	(0)	(0)	(0)	(0)	(0)	(0)	(0)	(0)

**Table 63. VRS engine cranking parameters register field description**

Field	Description
7-4 Threshold x	Input Comparator Threshold Value Selection, <a href="#">Table 55</a>
3-0 Filter Time x	Blanking Time Selection, <a href="#">Table 56</a>

### 5.7.3.3 SPI status registers

**Table 64. VRS status register**

Reg #	Hex			7	6	5	4	3	2	1	0
11	B	VRS Conditioner and ISO9141 Faults		Peak 8	Peak 4	Peak 2	Peak 1	X	Clamp-active VRSP	Clamp-active VRSN	ISO Overtemp OT
			Reset	(0)	(0)	(0)	(0)	(0)	(0)	(0)	(0)

**Table 65. VRS status register description field**

Field	Description
7-4 Peak x	Reflect the magnitude of the positive peak of the VRS input according to <a href="#">Table 57</a>
2-Clamp Active VRSP	Positive Clamp Active status 0-Clamp Value not reached 1-Clamp Value reached
1-Clamp Active VRSN	Negative Clamp Active status 0-Clamp Value not reached 1-Clamp Value reached

## 5.8 ISO9141 bus

Three pins are used to provide an ISO9141 K-line communication link for the MCU to support system diagnostics.

### 5.8.1 MTX output pin

MTX is the 5.0 V logic level serial input to the IC from the MCU.

### 5.8.2 MRX input pin

MRX is the 5.0 V logic level serial output line to the MCU.

### 5.8.3 ISO9141 pin

The ISO9141 pin is a bi-directional line with an internal 32 kΩ pull-up resistor to  $V_{PWR}$ . This allows the customer to save an external pull-up resistor.

### 5.8.4 Functions description

Three pins are used to provide an ISO9141 K-line communication link for the MCU to support system diagnostics. This system is consistent with the ISO9141 specification for signaling to and from the MCU.

K-Line has its own overtemperature protection and fault bit reporting.

### 5.8.5 SPI drivers registers

There is only one bit in the SPI Status register to indicate an overtemperature fault from the ISO9141 functional block. There are no Configuration or Control registers associated with this functional block.

**Table 66. ISO status register**

Reg #	Hex		7	6	5	4	3	2	1	0	
11	B	VRS Conditioner and ISO9141 Faults		Peak 8	Peak 4	Peak 2	Peak 1	x	Clamp-active VRSP	Clamp-active VRSN	ISO Overtemp OT
			Reset	(0)	(0)	(0)	(0)	(0)	(0)	(0)	(0)

**Table 67. ISO status register description field**

Field	Description
0-ISO Overtemp OT	Overtemp condition fault 0-No over temp condition reached 1-Overtemp condition reached

## 5.9 Mode code and revision number

One status register is reserved for reporting the model code and revision of the C circuits. The model code for the 33813 is 001. The revision code is the current version number for the circuit. This register is read-only.

**Table 68. Model code/revision number register**

Reg #	Hex			7	6	5	4	3	2	1	0
15	F	Model Code/ Revision Number* *Read Only except for POST Enable		Model Code 2	Model Code 1	Model Code 0	Rev #	Rev #	Rev #	Rev #	Rev #
		Reset		(0)	(1)	(0)	(X)	(X)	(X)	(X)	(X)

**Table 69. Model code/revision number register field description**

Field	Description
7-5 Model Code	Model Code #010 = 33813 device
4-0 Rev #	Rev #

## 5.10 SPI

### 5.10.1 PIN description

#### 5.10.1.1 SCLK input

The serial clock (SCLK) pin clocks the internal SPI shift register of the 33813. The SI data is latched into the input shift register on the rising edge of SCLK signal. The SO pin shifts status bits out on the falling edge of SCLK. The SO data is available for the MCU to read on the rising edge of SCLK. With CSB in a logic high state, signals on the SCLK and SI pins are ignored and the SO pin is in a high-impedance state. The SCLK signal consists of a 50% duty cycle with CMOS logic levels referenced to  $V_{CC}$ . All SPI transfers consist of exactly 16 SCLK pulses. If any more or less than 16 clock pulses are received within one frame of CSB going low and then high, a SPI error is reported in the SPI Status Register. The SPI error bit also sets whenever an invalid SPI message is received, even though it may contain 16 bits.

#### 5.10.1.2 CSB input

The system MCU selects which slave is to receive SPI communication using separate chip select (CSB) pins. With the CSB in a logic low state, SPI words may be sent to the 33813 via the serial input (SI) pin and status information is received by the MCU via the serial output (SO) pin. The falling edge of CSB enables the SO output and transfers status information into the SO buffer.

The rising edge of the CSB initiates the following operation:

- Disables the SO driver (high-impedance)
- Activates the received command word, allowing the 33813 to activate/deactivate output drivers

To avoid spurious data, the high-to-low and low-to-high transitions of the CSB signal must occur only when SCLK is in a logic low state. Internal to the 33813 device is an active pull-up to  $V_{CC}$  on CSB. In cases where voltage exists on CSB without the application of  $V_{CC}$ , no current flows from CSB to the VCC pin. This input requires CMOS logic levels referenced to  $V_{CC}$  and has an internal active pull-up current source.

### 5.10.1.3 SI input

The SI pin is used for serial instruction data input. SI information is latched into the input register on the rising edge of SCLK and the input data transitions on the falling edge of SCLK. A logic high state present on SI programs a one in the command word on the rising edge of the CSB signal. To program a complete word, 16 bits of information must be entered into the device. This input requires CMOS logic levels referenced to  $V_{CC}$ .

### 5.10.1.4 SO output

The SO pin is the output from the SPI shift register. The SO pin remains high-impedance until the CSB pin transitions to a logic low state. All normal operating drivers are reported as zero, all faulted drivers are reported as one. The negative transition of CSB enables the SO driver. The SI/SO shifting of the data follows a first-in-first-out protocol with both input and output words transferring the most significant bit (MSB) first. The serial output data is available to be latched by the MCU on the rising edge of SCLK. The SO data transitions on the falling edge of the SCLK. This output provides CMOS logic levels referenced to  $V_{CC}$ .

## 5.10.2 MCU SPI interface description

The 33813 device directly interfaces to a 5.0 V microcontroller unit (MCU) using a 16-bit serial peripheral interface (SPI) protocol. SPI serial clock frequencies up to 8.0 MHz can be used when programming and reading output status information (production tested at 1.0 MHz). [Figure 19](#) illustrates the SPI configuration between an MCU and one 33813.

Data is sent to the 33813 device through the SI input pin. As data is being clocked into the SI pin, other data is being clocked out of the device by the SO output pin. The response data received by the MCU during SPI communication depends on the previous SPI message sent to the device. The SPI can be used to read or write data to the configuration and control registers and to read or write the data contained in the status registers.

The MCU is only allowed to read or clear bits (write zeros) in the status register unless the Power ON Self-test (POST) enable bit in the control register is set. When the POST enable bit is set, the MCU can read and write zeros or ones to the status register. Note that the MCU must clear the POST enable bit before operation is resumed or the status register does not update with fault indications.

### 5.10.2.1 SPI integrity check

One SPI word is reserved as a SPI check message. When bits 12 through 15 are all zero, the SPI echoes the remaining 12-bit SPI word sent and flips bits 12 through 14, bit 15 remains a 0. This allows the MCU to poll the SPI and compare the received message to confirm the integrity of the SPI communication channel to the 33813. There is a SPI error bit in the SPI status register indicating if an incorrect SPI message has been received. The SPI error bit in the SPI status register is set whenever any SPI message error is detected.

**Important** A SCLK pulse count strategy has been implemented to ensure integrity of SPI communications. Only SPI messages consisting of 16 SCLK pulses are acknowledged. SPI messages consisting of other than 16 SCLK pulses are ignored by the device and reported as a SPI error. Invalid SPI messages, containing invalid commands or addresses are also flagged as a SPI error.

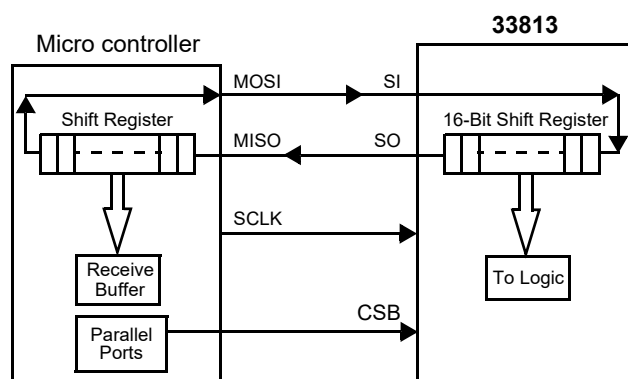

**Figure 19. SPI interface with microprocessor**

Two or more 33813 devices can be used in a module system. Multiple ICs can be SPI configured in parallel only. [Figure 19](#) demonstrates the configuration.

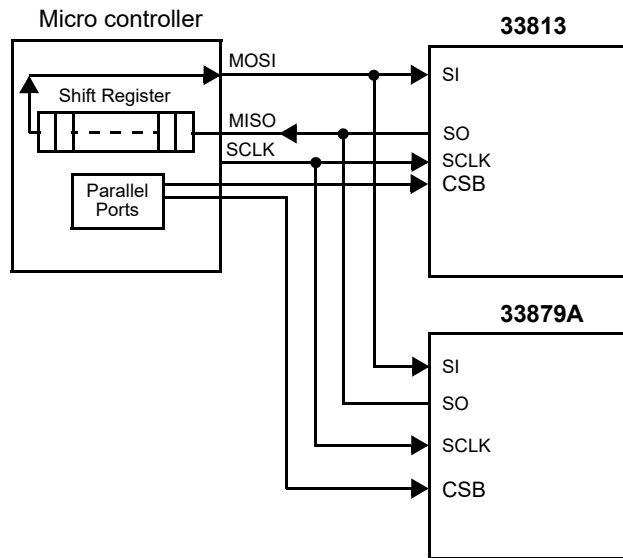

Figure 20. SPI parallel interface (only) with microprocessor

### 5.10.2.2 SPI register definitions

There are three basic SPI register types:

**Configuration registers** - used to set the operating modes and parameters for the 33813 functional blocks. Each output can be configured by setting the individual bits in the configuration register for output according to the descriptions in the previous functional descriptions for each particular output.

**Control registers** - used to turn outputs on and off and set the PWM duty cycle for outputs used as PWM outputs. Setting the temporary operating parameters for the watchdog timer and the VRS circuit is also used.

**Status registers** - used to announce faults and other values the MCU may need to act upon. Each output and functional block has a status register associated with it and the individual fault bits for each of the faults monitored are contained in these registers.

Non-fault bits in the status register can be set and cleared by the 33813 circuit. All status register bits not marked as 'x' can be cleared by the MCU only when the POST bit is zero (0). When the POST bit is one (1), the MCU can read or write any existing bit in the status register. Non-existing bits (marked with an 'x' in the table) cannot be changed from the default zero (0) value.

Entries in the following SPI Registers marked with an 'x' are non-existent bits. They are set to zero (0) by default and cannot be changed by reading or writing to them. They should be ignored when testing registers during POST.

### 5.10.2.3 SPI command summary

The SPI commands are defined as 16 bits with 4 address control bits and 12 command data bits. There are 7 separate commands used to set the operational parameters of device. The operational parameters are stored internally in 8-bit registers. Write commands write the data contained in the present SPI word whereas read commands must wait until the next SPI command is sent to read the data requested. Table 11 defines the commands and default state of the internal registers at POR. SPI commands may be sent to the device at any time while the device is in the Normal state. Messages sent are acted upon on the rising edge of the CSB input. The bit value returned equals bit value sent for this command.

Table 70. SPI command messages

Command	Control Address Bits				Data Bits												
	hex	15	14	13	12	11	10	9	8	7	6	5	4	3	2	1	0
SPI Check	0	0	0	0	0	X*	X*	X*	X*	X*	X*	X*	X*	X*	X*	X*	X*
Read Configuration Register	1	0	0	0	1	<0000> Internal Register Address				0/1	0/1	0/1	0/1	0/1	0/1	0/1	0/1
Write Configuration Register	2	0	0	1	0	<0000> Internal Register Address				0/1	0/1	0/1	0/1	0/1	0/1	0/1	0/1



**Table 70. SPI command messages (continued)**

Command	hex	Control Address Bits				Data Bits											
		15	14	13	12	11	10	9	8	7	6	5	4	3	2	1	0
Read Status Register	3	0	0	1	1	<0000> Internal Register Address				0/1	0/1	0/1	0/1	0/1	0/1	0/1	0/1
Write Status Register	4	0	1	0	0	<0000> Internal Register Address				0/1	0/1	0/1	0/1	0/1	0/1	0/1	0/1
Read Control Register	5	0	1	0	1	<0000> Internal Register Address				0/1	0/1	0/1	0/1	0/1	0/1	0/1	0/1
Write Control Register	6	0	1	1	0	<0000> Internal Register Address				0/1	0/1	0/1	0/1	0/1	0/1	0/1	0/1
SPI Check Response	7	0	1	1	1	X*	X*	X*	X*	X*	X*	X*	X*	X*	X*	X*	X*

There are seven SPI commands issued by the MCU to:

- Do a SPI Check verification
- Read the contents of the SPI configuration registers
- Write the contents of the SPI configuration registers
- Read the contents of the SPI status registers
- Write the contents of the SPI status registers
- Read the contents of the SPI control registers
- Write the contents of the SPI control registers

### 5.10.3 SPI drivers register

**Table 71. Power supply and any system fault status register**

Reg #	Hex		7	6	5	4	3	2	1	0
13	D	Power Supply and Any System Faults	Any System Faults	Keysw	Pwren	Batsw	SPI error	V <sub>PROT</sub> Short to Battery	V <sub>PROT</sub> Overtemp OT	V <sub>PROT</sub> Short to Ground
			Reset	(0)	(0)	(0)	(0)	(0)	(0)	(0)

**Table 72. Power supply and any system fault status register description field**

Field	Description
3-SPI Error	SPI Error fault status 0-No fault reported 1-Fault reported

## 5.11 SPI registers mapping

The SPI interface consists of three blocks of four, 8-bit read/write registers. There are three types of SPI registers:

- **Configuration registers** - These registers allow the MCU to configure the various parameters and options for the various functional blocks.
- **Control registers** - These registers are used to command the outputs on and off and set the PWM duty cycle values.
- **Status registers** - These registers report back faults and other conditions of the various functional blocks.

The following conventions are used in the SPI register tables:

- All default selections are in **BOLD** fonts.
- Non-default selections are in normal font.
- The first selection listed is the default selection.
- The binary values shown, (0 or 1) are the default values after a reset has occurred.

**Table 73. SPI configuration registers**

Reg #	Hex		7	6	5	4	3	2	1	0	
0	0	Injector 1 Driver		Retry Enable	X	X	OL Current Sink Enable	In-Rush Delay	OR/AND	PWM Freq. 1	PWM Freq. 0
			Reset	(0)	(0)	(0)	(1)	(0)	(0)	(0)	(0)
1	1	Not Used		X	X	X	X	X	X	X	X
			Reset	(0)	(0)	(0)	(0)	(0)	(0)	(0)	(0)
2	2	Relay 1 Driver		Retry Enable	X	X	OL Current Sink Enable	In-Rush Delay	OR/AND	PWM Freq. 1	PWM Freq. 0
			Reset	(0)	(0)	(0)	(1)	(0)	(0)	(0)	(0)
3	3	Relay 2 Driver		Retry Enable	Shutdown DisableSD D	X	OL Current Sink Enable	In-Rush Delay	OR/AND	PWM Freq. 1	PWM Freq. 0
			Reset	(0)	(0)	(0)	(1)	(0)	(0)	(0)	(0)
4	4	Tachometer Driver		Retry Enable	Vrsout/ LSD	Vrsout/ Osc. mode	N16/OL Current Sink Enable	N8/In-Rush Delay	N4/Osc 2	N2/Osc 1/ PWM Freq. 1	N1/Osc 0/ PWM Freq. 0
			Reset	(0)	(0)	(0)	(0)	(0)	(0)	(0)	(1)
5	5	Lamp Driver		Retry Enable	X	X	OL Current Sink Enable	In-Rush Delay	X	PWM Freq. 1	PWM Freq. 0
			Reset	(0)	(0)	(0)	(1)	(1)	(0)	(0)	(0)
6	6	Battery Switch Logic Output		HSD Mode	X	X	X	X	X	PWM Freq.1	PWM Freq. 0
			Reset	(0)	(0)	(0)	(0)	(0)	(0)	(0)	(0)
7	7	O2 Heater Pre-driver		GPGD/IGN Select	Retry Enable	X	OL Current Sink	X	OR/AND	PWM Freq. 1	PWM Freq. 0
			Reset	(0)	(0)	(0)	(1)	(0)	(0)	(0)	(0)
8	8	Ignition 1 Pre-driver		GPGD/IGN Select	Retry Enable	X	OL Current Sink	X	OR/AND	PWM Freq. 1	PWM Freq. 0
			Reset	(1)	(0)	(0)	(0)	(0)	(0)	(0)	(0)
9	9	Not Used		X	X	X	X	X	X	X	X
			Reset	(0)	(0)	(0)	(0)	(0)	(0)	(0)	(0)
10	A	Watchdog Parameters		Disable/ Enable	Load Time x1 sec	Load Time x100 ms	Load Time x10 ms	Load Time 8	Load Time 4	Load Time 2	Load Time 1
			Reset	(1)	(1)	(0)	(0)	(1)	(0)	(1)	(0)
11	B	VRS Engine Running Parameters		Threshold 3	Threshold 2	Threshold 1	Threshold 0	Filter Time 3	Filter Time 2	Filter Time 1	Filter Time 0
			Reset	(0)	(1)	(0)	(1)	(0)	(0)	(1)	(1)
12	C	VRS Automatic Parameters		mantiss 8	mantiss 4	mantiss 2	mantiss 1	exponent 8	exponent 4	exponent 2	exponent 1
			Reset	(0)	(0)	(1)	(0)	(0)	(0)	(0)	(1)
13	D	VRS Miscellaneous Parameters		Man./Auto	Disable VRS	X	High/Low Ref	De-glitch	Gnd VRSN	Inv Inputs	Disable 2.5 V CM
			Reset	(0)	(0)	(0)	(0)	(0)	(0)	(0)	(0)

**Table 74. SPI control registers**

Reg #	Hex		7	6	5	4	3	2	1	0	
0	0	Main OFF/ON Control		INJ1	X	REL1	REL2	LAMP	IGN1	X	O2H
			Reset	(0)	(0)	(0)	(0)	(0)	(0)	(0)	(0)
1	1	Other OFF/ON Control		Pwren OFF/ON	POST Enable OFF/ON	X	VProt OFF/ ON	X	Batsw OFF/ON	Tach OFF/ON	RESET internal only
			Reset	(0)	(0)	(0)	(1)	(0)	(0)	(1)	(0)
2	2	Injector 1 Driver		X	PWM6	PWM5	PWM4	PWM3	PWM2	PWM1	PWM0
			Reset	(0)	(0)	(0)	(0)	(0)	(0)	(0)	(0)
3	3	Not Used		X	X	X	X	X	X	X	X
			Reset	(0)	(0)	(0)	(0)	(0)	(0)	(0)	(0)
4	4	Relay 1 Driver		X	PWM6	PWM5	PWM4	PWM3	PWM2	PWM1	PWM0
			Reset	(0)	(0)	(0)	(0)	(0)	(0)	(0)	(0)
5	5	Relay 2 Driver		X	PWM6	PWM5	PWM4	PWM3	PWM2	PWM1	PWM0
			Reset	(0)	(0)	(0)	(0)	(0)	(0)	(0)	(0)
6	6	Tachometer Driver		X	PWM6	PWM5	PWM4	PWM3	PWM2	PWM1	PWM0
			Reset	(0)	(0)	(0)	(0)	(0)	(0)	(0)	(0)
7	7	Lamp Driver		X	PWM6	PWM5	PWM4	PWM3	PWM2	PWM1	PWM0
			Reset	(0)	(0)	(0)	(0)	(0)	(0)	(0)	(0)
8	8	Batsw		X	PWM6	PWM5	PWM4	PWM3	PWM2	PWM1	PWM0
			Reset	(0)	(0)	(0)	(0)	(0)	(0)	(0)	(0)
9	9	O2 Heater Pre-driver		X	PWM6	PWM5	PWM4	PWM3	PWM2	PWM1	PWM0
			Reset	(0)	(0)	(0)	(0)	(0)	(0)	(0)	(0)
10	A	Ignition 1 Pre-driver		X	PWM6	PWM5	PWM4	PWM3	PWM2	PWM1	PWM0
			Reset	(0)	(0)	(0)	(0)	(0)	(0)	(0)	(0)
11	B	Not Used		X	X	X	X	X	X	X	X
			Reset	(0)	(0)	(0)	(0)	(0)	(0)	(0)	(0)
12	C	Watchdog		WDRFSH	Load Time x1 sec	Load Time x100 ms	Load Time x10 ms	Load Time 8	Load Time 4	Load Time 2	Load Time 1
			Reset	(0)	(0)	(0)	(0)	(0)	(0)	(0)	(0)
13	D	VRS Engine Cranking Parameters		Threshold 3	Threshold 2	Threshold 1	Threshold 0	Filter Time 3	Filter Time 2	Filter Time 1	Filter Time 0
			Reset	(0)	(0)	(0)	(0)	(0)	(0)	(0)	(0)

**Table 75. SPI status registers**

Reg #	Hex		7	6	5	4	3	2	1	0	
0	0	Injector 1 Driver Faults		Faults	X	X	X	Open Load OL	Over - current OC	Overtemp OT	Short Gnd SG
			Reset	(0)	(0)	(0)	(0)	(0)	(0)	(0)	(0)
1	1	Not Used		X	X	X	X	X	X	X	X
			Reset	(0)	(0)	(0)	(0)	(0)	(0)	(0)	(0)
2	2	Relay 1 Driver Faults		Faults	X	X	X	Open Load OL	Overcurrent OC	Overtemp OT	Short Gnd SG
			Reset	(0)	(0)	(0)	(0)	(0)	(0)	(0)	(0)

**Table 75. SPI status registers (continued)**

3	3	Relay 2 Driver Faults		Faults	X	X	X	Open Load OL	Overcurrent OC	Overtemp OT	Short Gnd SG
			Reset	(0)	(0)	(0)	(0)	(0)	(0)	(0)	(0)
4	4	Tachometer Driver Faults		Faults	X	X	X	Open Load OL	Overcurrent OC	Overtemp OT	X
			Reset	(0)	(0)	(0)	(0)	(0)	(0)	(0)	(0)
5	5	Lamp Driver Faults		Faults	X	X	X	Open Load OL	Overcurrent OC	Overtemp OT	Short Gnd SG
			Reset	(0)	(0)	(0)	(0)	(0)	(0)	(0)	(0)
7	7	O2 Heater Pre-driver Faults		Faults	X	X	X	Open Load OL	Overcurrent OC	X	X
			Reset	(0)	(0)	(0)	(0)	(0)	(0)	(0)	(0)
8	8	Ignition 1 Pre-driver Faults		Faults	X	X	X	Open Load OL	Overcurrent OC	X	X
			Reset	(0)	(0)	(0)	(0)	(0)	(0)	(0)	(0)
9	9	Not Used		X	X	X	X	X	X	X	X
			Reset	(0)	(0)	(0)	(0)	(0)	(0)	(0)	(0)
10	A	Watchdog State		Enable/ Disable	WD timer bit 6	WD timer bit 5	WD timer bit 4	WD timer bit 3	WD timer bit 2	WD timer bit 1	WD timer bit 0
			Reset	(0)	(0)	(0)	(0)	(0)	(0)	(0)	(0)
11	B	VRS Conditioner and ISO9141 Faults		Peak 8	Peak 4	Peak 2	Peak 1	X	Clamp- active VRSP	Clamp- active VRSN	ISO Overtemp OT
			Reset	(0)	(0)	(0)	(0)	(0)	(0)	(0)	(0)
13	D	Power Supply and Any System Faults		Any System Faults	Keysw	Pwren	Batsw	SPI Error	V <sub>PROT</sub> Short to Battery	V <sub>PROT</sub> Overtemp OT	V <sub>PROT</sub> Short to Ground
			Reset	(0)	(1)	(0)	(0)	(0)	(0)	(0)	(0)
14	E	System On/Off Indicators		INJ1 Off/On	X	REL1 Off/On	REL2 Off/On	LAMP Off/On	IGN1 Off/On	X	O2H Off/On
			Reset	(0)	(0)	(0)	(0)	(0)	(0)	(0)	(0)
15	F	Model Code/ Revision Number* *Read Only except for POST Enable		Model Code 2	Model Code 1	Model Code 0	Rev #	Rev #	Rev #	Rev #	Rev #
			Reset	(0)	(1)	(0)	(0)	(0)	(0)	(0)	(0)

**Table 76. SPI configuration bits R/W access**

R e g #	Hex	Description	7		6		5		4		3		2		1		0		
Configuration registers	0	0	Injector 1 driver	Retry enable	R/W	x	R <sup>(27)</sup>	x	R <sup>(27)</sup>	OL current sink enable	R/W	In-rush delay	R/W	OR/AND	R/W	PWM Freq. 1	R/W	PWM Freq. 0	R/W
	1	1	Not used	x	R <sup>(27)</sup>	x	R <sup>(27)</sup>	x	R <sup>(27)</sup>	x	R <sup>(27)</sup>	x	R <sup>(27)</sup>	x	R <sup>(27)</sup>	x	R <sup>(27)</sup>	x	R <sup>(27)</sup>
	2	2	Relay 1 driver	Retry enable	R/W	x	R <sup>(27)</sup>	x	R <sup>(27)</sup>	OL current sink enable	R/W	In-rush delay	R/W	OR/AND	R/W	PWM Freq. 1	R/W	PWM Freq. 0	R/W
	3	3	Relay 2 driver	Retry enable	R/W	Shut down disable SDD	R/W	x		OL current sink enable		In-rush delay	R/W	OR/AND	R/W	PWM Freq. 1	R/W	PWM Freq. 0	R/W
	4	4	Tachometer driver	Retry enable	R/W	VRSout /LSD	R/W	Vrsout/ Osc mode	R/W	N16/OL current sink enable	R/W	N8/In-rush delay	R/W	N4/Osc 2	R/W	N2/OSC 1/ PWM Freq.1	R/W	N1/OSC 0/ PWM Freq.0	R/W
	5	5	Lamp driver	Retry enable	R/W	x	R <sup>(27)</sup>	x	R <sup>(27)</sup>	OL current sink enable	R/W	In-rush delay	R/W	x	R <sup>(27)</sup>	PWM Freq. 1	R/W	PWM Freq. 0	R/W
	6	6	Battery switch logic output	HSD mode	R/W	x	R <sup>(27)</sup>	x	R <sup>(27)</sup>	x	(28)	x	R <sup>(27)</sup>	x	R <sup>(27)</sup>	PWM Freq. 1	R/W	PWM Freq. 0	R/W
	7	7	O2 heater predriver	CPGD/ IGN select	R/W	Retry enable	R/W	x	R <sup>(27)</sup>	OL current sink enable	R/W	x	R <sup>(27)</sup>	OR/AND	R/W	PWM Freq. 1	R/W	PWM Freq. 0	R/W
	8	8	Ignition 1 predriver	CPGD/ IGN select	R/W	Retry enable	R/W	x	R <sup>(27)</sup>	OL current sink enable	R/W	x	R <sup>(27)</sup>	OR/AND	R/W	PWM Freq. 1	R/W	PWM Freq. 0	R/W
	9	9	Not used	x	R <sup>(27)</sup>	x	R <sup>(27)</sup>	x	R <sup>(27)</sup>	x	R <sup>(27)</sup>	x	R <sup>(27)</sup>	x	R <sup>(27)</sup>	x	R <sup>(27)</sup>	x	R <sup>(27)</sup>
	10	A	Watchdog parameters	Disable/ Enable	R/W	Load time x1 sec	R/W	Load time x100 ms	R/W	Load time x10 ms	R/W	Load time 8	R/W	Load time 4	R/W	Load time 2	R/W	Load time 1	R/W
	11	B	VRS engine running parameters	Threshold 3	R/W	Thresh old 2	R/W	Threshold 1	R/W	Threshold 0	R/W	Filter time 3	R/W	Filter time 2	R/W	Filter time 1	R/W	Filter time 0	R/W
	12	C	VRS automatic parameters	Mantiss 8	R/W	Mantiss 4	R/W	Mantiss 2	R/W	Mantiss 1	R/W	Exponent 8	R/W	Exponent 4	R/W	Exponent 2	R/W	Exponent 1	R/W
13	D	VRS miscellaneous parameters	Man/Auto	R/W	Disable VRS	R/W	x	R <sup>(27)</sup>	High/low ref	R/W	De-glitch	R/W	GND VRSN	R/W	Inv inputs	R/W	Disable 2.5 V CM	R/W	
Notes 27. Only read as 0 28. Cannot be written, always read as 0																			

**Table 77. SPI control bits R/W access**

Reg #	Hex	Description	7		6		5		4		3		2		1		0		
Control registers	0	0	Main ON/OFF control	INJ1	R/W	INJ2	R/W	REL1	R/W	REL2	R/W	LAMP	R/W	IGN1	R/W	IGN2	R/W	O2H	R/W
	1	1	Other OFF/ON control	Pwren OFF/ON	R <sup>(29)</sup>	POST enable OFF/ON	R/W	x	R <sup>(30)</sup>	Vprot OFF/ON	R/W	x	R <sup>(30)</sup>	Batsw OFF/ON	R/W	Tach OFF/ON	R/W	RESET internal only	W
	2	2	Injector 1 driver	x	R <sup>(29)</sup>	PWM6	R/W	PWM5	R/W	PWM4	R/W	PWM3	R/W	PWM2	R/W	PWM1	R/W	PWM0	R/W
	3	3	Not used	x	R <sup>(29)</sup>	x	R <sup>(29)</sup>	x	R <sup>(29)</sup>	x	R <sup>(29)</sup>	x	R <sup>(29)</sup>	x	R <sup>(29)</sup>	x	R <sup>(29)</sup>	x	R <sup>(29)</sup>
	4	4	Relay 1 driver	x	R <sup>(29)</sup>	PWM6	R/W	PWM5	R/W	PWM4	R/W	PWM3	R/W	PWM2	R/W	PWM1	R/W	PWM0	R/W
	5	5	Relay 2 driver	x	R <sup>(29)</sup>	PWM6	R/W	PWM5	R/W	PWM4	R/W	PWM3	R/W	PWM2	R/W	PWM1	R/W	PWM0	R/W
	6	6	Tachometer driver	x	R <sup>(29)</sup>	PWM6	R/W	PWM5	R/W	PWM4	R/W	PWM3	R/W	PWM2	R/W	PWM1	R/W	PWM0	R/W
	7	7	Lamp driver	x	R <sup>(29)</sup>	PWM6	R/W	PWM5	R/W	PWM4	R/W	PWM3	R/W	PWM2	R/W	PWM1	R/W	PWM0	R/W
	8	8	Batsw	x	R <sup>(29)</sup>	PWM6	R/W	PWM5	R/W	PWM4	R/W	PWM3	R/W	PWM2	R/W	PWM1	R/W	PWM0	R/W
	9	9	O2 heater predriver	x	R <sup>(29)</sup>	PWM6	R/W	PWM5	R/W	PWM4	R/W	PWM3	R/W	PWM2	R/W	PWM1	R/W	PWM0	R/W
	10	A	Ignition 1 predriver	x	R <sup>(29)</sup>	PWM6	R/W	PWM5	R/W	PWM4	R/W	PWM3	R/W	PWM2	R/W	PWM1	R/W	PWM0	R/W
	11	B	Not used	x	R <sup>(29)</sup>	x	R <sup>(29)</sup>	x	R <sup>(29)</sup>	x	R <sup>(29)</sup>	x	R <sup>(29)</sup>	x	R <sup>(29)</sup>	x	R <sup>(29)</sup>	x	R <sup>(29)</sup>
	12	C	Watchdog	WDRFSH	(31)	Load time x1 sec	R/W	Load time x100 ms	R/W	Load time x10 ms	R/W	Load time 8	R/W	Load time 4	R/W	Load time 2	R/W	Load time 1	R/W
13	D	VRS engine cranking parameters	Threshold 3	R/W	Threshold 2	R/W	Threshold 1	R/W	Threshold 0	R/W	Filter time 3	R/W	Filter time 2	R/W	Filter time 1	R/W	Filter time 0	R/W	
<b>Notes</b> 29. Only read as 0 30. Cannot be written, always read as 0 31. Can only be written to 1. Write 0 has no effect. Only read as 0.																			

Table 78. SPI status bits R/W access

R e g #	Hex	Description	7		6		5		4		3		2		1		0		
Status registers	0	0	Injector 1 driver faults	Faults	R <sup>(32)</sup>	x	R <sup>(33)</sup>	x	R <sup>(33)</sup>	x	R <sup>(33)</sup>	Openload OL	R <sup>(34)</sup>	Over current OC	R <sup>(34)</sup>	Over temp OT	R <sup>(34)</sup>	Short to GND (SG)	R <sup>(34)</sup>
	1	1	Not used	x	R <sup>(33)</sup>	x	R <sup>(33)</sup>	x	R <sup>(33)</sup>	x	R <sup>(33)</sup>	x	R <sup>(33)</sup>	x	R <sup>(33)</sup>	x	R <sup>(33)</sup>	x	R <sup>(33)</sup>
	2	2	Relay 1 driver faults	Faults	R <sup>(32)</sup>	x	R <sup>(33)</sup>	x	R <sup>(33)</sup>	x	R <sup>(33)</sup>	Openload OL	R <sup>(34)</sup>	Over current OC	R <sup>(34)</sup>	Over temp OT	R <sup>(34)</sup>	Short to GND (SG)	R <sup>(34)</sup>
	3	3	Relay 2 driver faults	Faults	R <sup>(32)</sup>	x	R <sup>(33)</sup>	x	R <sup>(33)</sup>	x	R <sup>(33)</sup>	Openload OL	R <sup>(34)</sup>	Over current OC	R <sup>(34)</sup>	Over temp OT	R <sup>(34)</sup>	Short to GND (SG)	R <sup>(34)</sup>
	4	4	Tachometer driver faults	Faults	R <sup>(32)</sup>	x	R <sup>(33)</sup>	x	R <sup>(33)</sup>	x	R <sup>(33)</sup>	Openload OL	R <sup>(34)</sup>	Over current OC	R <sup>(34)</sup>	Over temp OT	R <sup>(34)</sup>	x	R <sup>(33)</sup>
	5	5	Lamp driver faults	Faults	R <sup>(32)</sup>	x	R <sup>(33)</sup>	x	R <sup>(33)</sup>	x	R <sup>(33)</sup>	Openload OL	R <sup>(34)</sup>	Over current OC	R <sup>(34)</sup>	Over temp OT	R <sup>(34)</sup>	Short to GND (SG)	R <sup>(34)</sup>
	7	7	O2 heater predriver faults	Faults	R <sup>(32)</sup>	x	R <sup>(33)</sup>	x	R <sup>(33)</sup>	x	R <sup>(33)</sup>	Openload OL	R <sup>(34)</sup>	Over current OC	R <sup>(34)</sup>	x	R <sup>(33)</sup>	x	R <sup>(33)</sup>
8	8	Ignition 1 predriver faults	Faults	R <sup>(32)</sup>	x	R <sup>(33)</sup>	x	R <sup>(33)</sup>	x	R <sup>(33)</sup>	Openload OL	R <sup>(34)</sup>	Over current OC	R <sup>(34)</sup>	x	R <sup>(33)</sup>	x	R <sup>(33)</sup>	
9	9	Not used	x	R <sup>(33)</sup>	x	R <sup>(33)</sup>	x	R <sup>(33)</sup>	x	R <sup>(33)</sup>	x	R <sup>(33)</sup>	x	R <sup>(34)</sup>	x	R <sup>(33)</sup>	x	R <sup>(33)</sup>	
10	A	Watchdog state	Disable/Enable	R	WD timer bit 6	R	WD timer bit 5	R	WD timer bit 4	R	WD timer bit 3	R	WD timer bit 2	R	WD timer bit 1	R	WD timer bit 0	R	
11	B	VRS conditioner and ISO 9141 faults	Peak 8	R	Peak 4	R	Peak 2	R	Peak 1	R	x	R <sup>(33)</sup>	Clamp active VRSP	R	Clamp active VRSN	R	ISO overtemp OT	R <sup>(34)</sup>	
13	D	Power supply and any system faults	Any system faults	R <sup>(32)</sup>	Keysw	R	PWREN	R	BATSW	R	SPI error	R <sup>(34)</sup>	Vprot short to battery	R <sup>(34)</sup>	Vprot overtemp	R <sup>(34)</sup>	Vprot short to ground	R <sup>(34)</sup>	
14	E	System On/Off indicators	INJ1 OFF/ON	R	INJ12 OFF/ON	R	REL1 OFF/ON	R	REL2 OFF/ON	R	LAMP OFF/ON	R	IGN1 OFF/ON	R	IGN2 OFF/ON	R	O2H OFF/ON	R	
15	F	Model code/revision number	Model code 2	R	Model code 1	R	Model code 0	R	REV#	R	Rev#	R	Rev#	R	Rev#	R	Rev#	R	
<p>Notes</p> <p>32. Can only be written to 0 when faults have disappeared</p> <p>33. Only read as 0</p> <p>34. Can only be written to 0 when the fault has disappeared</p>																			

## 6 Typical applications

### 6.1 Output OFF open load fault

An Output OFF Open Load Fault is the detection and reporting of an open load when the corresponding output is disabled (input bit programmed to a logic low state). The Output OFF Open Load Fault is detected by comparing the drain-to-source voltage of the specific MOSFET output to an internally generated reference. Each output has one dedicated comparator for this purpose.

Each output has an internal pull-down current source or resistor. The pull-down current sources are enabled on power-up and must be enabled for Open Load Detect to function. In cases where the Open Load Detect current is disabled, the status bit always responds with logic 0. The device only shuts down the pull-down current in Sleep mode or when disabled via the SPI.

During output switching, especially with capacitive loads, a false Output OFF Open Load Fault may be triggered. To prevent this false fault from being reported, an internal fault filter of 100 to 450  $\mu$ s is incorporated. The duration for which a false fault may be reported is a function of the load impedance  $R_{DS(ON)}$ ,  $C_{OUT}$  of the MOSFET as well as the supply voltage  $V_{PWR}$ . The rising edge of CSB triggers the built-in fault delay timer. The timer must time out before the fault comparator is enabled to detect a faulted threshold. Once the condition causing the Open Load Fault is removed, the device resumes normal operation. The Open Load Fault, however, is latched in the output SO Response register for the MCU to read.

### 6.2 Low voltage operation

Low voltage condition ( $6.5\text{ V} < V_{PWR} < 9.0\text{ V}$ ) operates per the command word, however parameter tables may be out of specification and status reported on SO pin is not guaranteed.

### 6.3 Low-side injector driver voltage clamp

Each Injector output of the 33813 incorporates an internal voltage clamp to provide fast turn-OFF and transient protection. Each clamp independently limits the drain-to-source voltage to  $V_{CL}$ . The total energy clamped ( $E_J$ ) can be calculated by multiplying the current area under the current curve ( $I_A$ ) times the clamp voltage ( $V_{CL}$ ) (see [Figure 21](#)). Characterization of the output clamps indicates the maximum energy to be 100 mJ at 125 °C junction temperature per output.

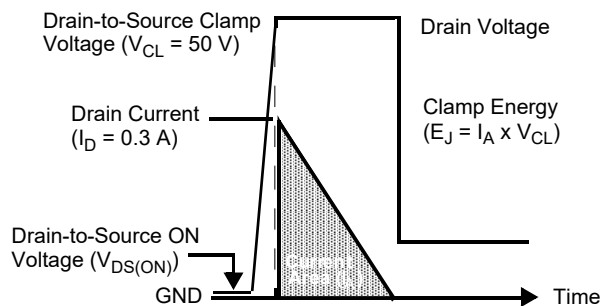

Figure 21. Output voltage clamping

### 6.4 Reverse battery protection

The 33813 device requires external reverse battery protection on the  $V_{PWR}$  pin. All outputs consist of a power MOSFET with an integral substrate diode. During a reverse battery condition, current flows through the load via the substrate diode. Under this condition load, devices turn on. If load reverse battery protection is desired, a diode must be placed in series with the load.



# 7 Packaging

## 7.1 Package mechanical dimensions

Package dimensions are provided in package drawings. To find the most current package outline drawing, go to [www.nxp.com](http://www.nxp.com) and perform a keyword search for the drawing's document number.

**Table 79. 98A reference documents**

Package	Suffix	Package outline drawing number
48-Pin LQFP-EP	AE	98ASA00737D

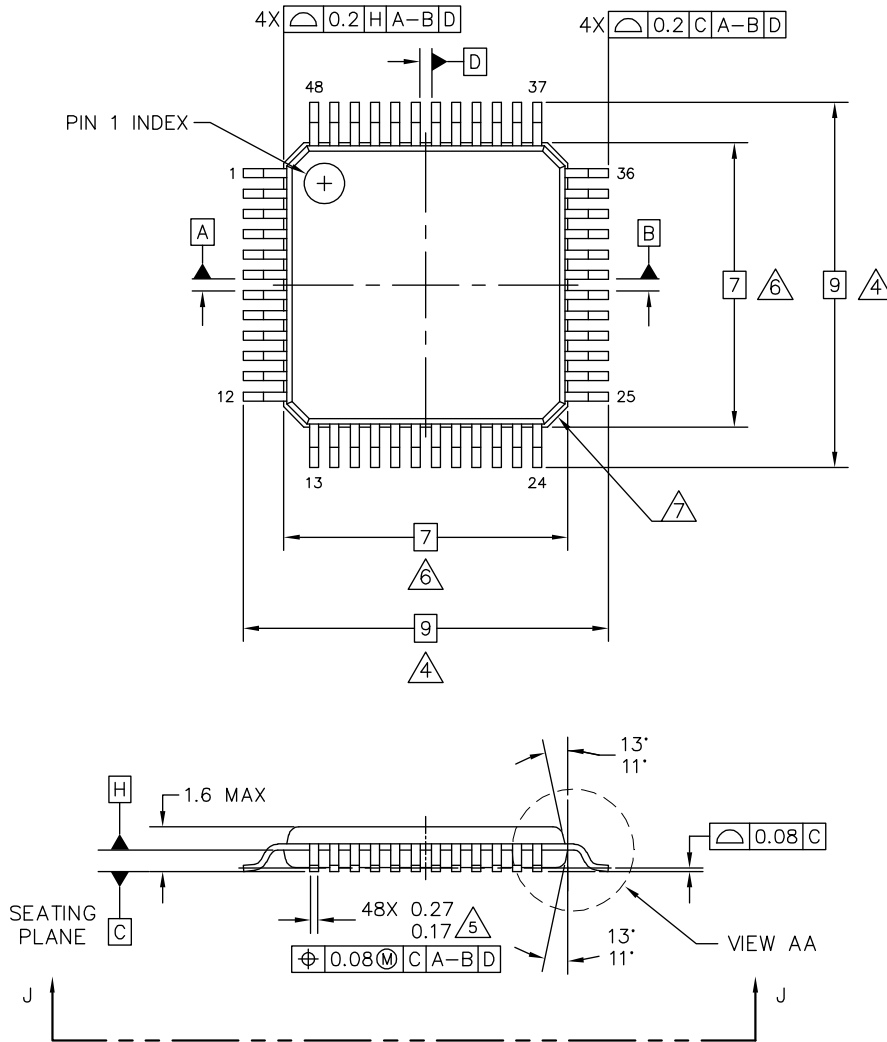

© NXP SEMICONDUCTORS N. V. ALL RIGHTS RESERVED	MECHANICAL OUTLINE	PRINT VERSION NOT TO SCALE
TITLE: 48 LEAD LQFP, 7X7X1.4 PKG, 0.5 PITCH, 4.15X4.15 EXPOSED PAD	DOCUMENT NO: 98ASA00737D	REV: A
	STANDARD: JEDEC MS-026 BBC	
	SOT1571-3	12 JAN 2016

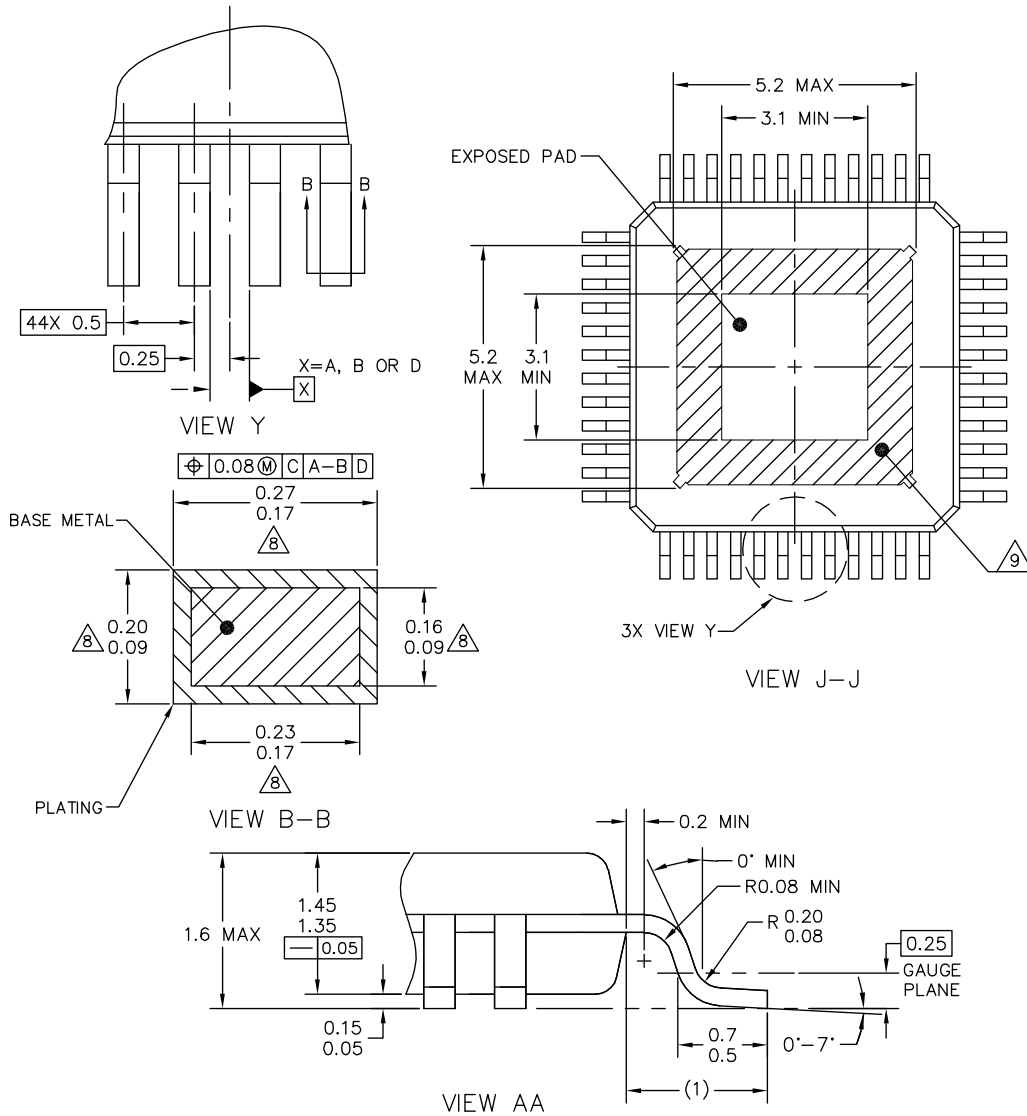

© NXP SEMICONDUCTORS N. V. ALL RIGHTS RESERVED	MECHANICAL OUTLINE	PRINT VERSION NOT TO SCALE
TITLE: 48 LEAD LQFP, 7X7X1.4 PKG, 0.5 PITCH, 4.15X4.15 EXPOSED PAD	DOCUMENT NO: 98ASA00737D	REV: A
	STANDARD: JEDEC MS-026 BBC	
	SOT1571-3	12 JAN 2016



NOTES:

1. DIMENSIONS ARE IN MILLIMETERS.
2. DIMENSIONING AND TOLERANCING PER ASME Y14.5M-1994.
3. DATUMS A, B AND D TO BE DETERMINED AT DATUM PLANE H.
4. DIMENSION TO BE DETERMINED AT SEATING PLANE C.
5. THIS DIMENSION DOES NOT INCLUDE DAMBAR PROTRUSION. ALLOWABLE DAMBAR PROTRUSION SHALL NOT CAUSE THE LEAD WIDTH TO EXCEED THE UPPER LIMIT BY MORE THAN 0.08MM AT MAXIMUM MATERIAL CONDITION. DAMBAR CANNOT BE LOCATED ON THE LOWER RADIUS OR THE FOOT. MINIMUM SPACE BETWEEN PROTRUSION AND ADJACENT LEAD SHALL NOT BE LESS THAN 0.07MM.
6. THIS DIMENSION DOES NOT INCLUDE MOLD PROTRUSION. ALLOWABLE PROTRUSION IS 0.25MM PER SIDE. THIS DIMENSION IS MAXIMUM PLASTIC BODY SIZE DIMENSION INCLUDING MOLD MISMATCH.
7. EXACT SHAPE OF EACH CORNER IS OPTIONAL.
8. THESE DIMENSIONS APPLY TO THE FLAT SECTION OF THE LEAD BETWEEN 0.1MM AND 0.25MM FROM THE LEAD TIP.
9. HATCHED AREA TO BE KEEP OUT ZONE FOR PCB ROUTING.

© NXP SEMICONDUCTORS N. V. ALL RIGHTS RESERVED	MECHANICAL OUTLINE	PRINT VERSION NOT TO SCALE
TITLE: 48 LEAD LQFP, 7X7X1.4 PKG, 0.5 PITCH, 4.15X4.15 EXPOSED PAD	DOCUMENT NO: 98ASA00737D	REV: A
	STANDARD: JEDEC MS-026 BBC	
	SOT1571-3	12 JAN 2016

## 8 Revision history

REVISION	DATE	DESCRIPTION OF CHANGES
1.0	3/2012	<ul style="list-style-type: none"> <li>Initial release</li> <li>Removed Freescale Confidential Proprietary on page 1</li> </ul>
2.0	8/2012	<ul style="list-style-type: none"> <li>Changed second instance of "VRS Low-state Output Voltage" to "VRS High-state Output Voltage" on <a href="#">Page 14</a></li> <li>Changed the word "Voltage" to "Current" on <a href="#">Page 15</a></li> <li>Replaced "ISO914" (incorrect) with "ISO9141" on p.27</li> <li>Adjusted Peak Values in <a href="#">Table 57</a></li> <li>Changed <a href="#">VPP Supply Voltage (If supplied externally and not using internal VPP regulator)</a> to reflect two separate limits</li> <li>Changed VPROT Output Voltage (tracks VCC) IVCC = 100 mA, IVPROT = 50 mA 9.0 V &lt; VPWR &lt; 18 V Max limit.</li> <li>Changed Typ and Max limit on <a href="#">Load Regulation (Both VCC and VPROT) measured from 10% - 90% of IVCC_C and IPROT_C, VPWR = 13 V</a></li> <li>Changed Min limit on <a href="#">VRS Negative Clamp Voltage at ICLAMP = 10 mA</a></li> <li>Removed any remaining references to INJIN2, INJOUT2, IGNIN2, IGNOUT2, and IGNFB2</li> <li>Added <a href="#">Typical electrical characteristics</a></li> <li>Added <a href="#">VRS schematic</a></li> <li>Updated <a href="#">Table 56</a></li> <li>Added lower limit note for <a href="#">VCC Output Current Limiting</a></li> </ul>
3.0	4/2013	<ul style="list-style-type: none"> <li>Updated <a href="#">Output Clamp Energy (INJOUT1, ROUT1, ROUT2)</a> and added <a href="#">Output Clamp Energy (LAMPOUT)</a></li> <li>Added <a href="#">ESD Voltage</a></li> <li>Added clarification to <a href="#">5.5.1.5. LAMPOUT driver output, page 34</a></li> </ul>
4.0	5/2013	<ul style="list-style-type: none"> <li>Added symbol to <a href="#">Output OFF Open Load Detection Current TachOut</a></li> <li>Corrected limits to <a href="#">Pre-driver</a></li> <li>Corrected limits to <a href="#">VRS Positive Clamp Voltage at ICLAMP = 10 mA</a></li> <li>Deleted SCLK Input Current parameter for <a href="#">DIGITAL INTERFACE (MRX, MTX, CSB, SI, SCLK, SO, RINx, O2HIN, INJIN1, IGNIN1, BATSW, VRSOUT, RESETB)</a></li> </ul>
5.0	5/2013	<ul style="list-style-type: none"> <li>Changed part number from PC33813AE to MC33813AE in <a href="#">Table 1, Orderable part variations</a></li> </ul>
6.0	5/2013	<ul style="list-style-type: none"> <li>Corrected package from 98ASA00173D to 98ASA00430D</li> </ul>
7.0	10/2015	<ul style="list-style-type: none"> <li>Corrected package from 98ASA00430D to 98ASA00737D and associated images as per PCN # 16956</li> </ul>
8.0	3/2016	<ul style="list-style-type: none"> <li>Rewrite of section <a href="#">4.4. Timing diagrams, page 17</a></li> <li>Updated the IC description and list of features</li> <li>Updated <a href="#">Figure 1</a> with better representations</li> <li>Updated description for pre-driver pins in <a href="#">3.2. Pin definitions, page 5</a></li> <li>Removed Output clamp energy in continuous operation mode</li> <li>Corrected VESD1 parameter</li> <li>Updated the INJOUT1 Output Self Limiting Current low limit from 1.6A to 1.8A</li> <li>Corrected the description in pre-driver section for VIGNFB/GPGD</li> <li>ISO9141 section: Added Overtemperature threshold &amp; Hysteresis parameter</li> <li>Added KEYSW Filter time parameter</li> <li>Updated <a href="#">4.5.2. VCC and VPROT characteristics, page 19</a></li> <li>Rewrite of section <a href="#">5. General IC functional description and application information, page 21</a></li> <li>Corrected typo (100 KHz changed to 100 Hz)</li> <li>Updated <a href="#">5.7.2.6. GND VRSN bit, page 50</a></li> <li>Updated data sheet document format and style</li> </ul>
	4/2016	<ul style="list-style-type: none"> <li>Corrected <a href="#">Figure 16</a></li> </ul>
9.0	9/2016	<ul style="list-style-type: none"> <li>Added V<sub>CC</sub> max rating (7.0 V)</li> <li>Clarified overcurrent and short to VBAT fault bit reporting for drivers and pre-drivers</li> <li>Corrected the effect of open load sink current disable bit</li> <li>Added the 32 kΩ internal pull-up present on ISO Pin</li> <li>Updated <a href="#">Figure 13</a></li> </ul>
10.0	7/2017	<ul style="list-style-type: none"> <li>Design enhancement to fulfill ISO 16750 test, and modification of the state machine related to exit condition from Prepare to Shutdown mode as per CIN# 201706024I</li> <li>Updated <a href="#">Figure 13</a></li> <li>Added note to <a href="#">5.1.2.4. Prepare to shutdown state, page 23</a></li> </ul>

REVISION	DATE	DESCRIPTION OF CHANGES
11.0	6/2018	<ul style="list-style-type: none"><li>• Minor typo corrections</li><li>• Added <a href="#">Table 20</a>, <a href="#">Table 76</a>, <a href="#">Table 77</a> and <a href="#">Table 78</a></li></ul>
12.0	12/2019	<ul style="list-style-type: none"><li>• Updated I<sub>RESET_LEAKAGE_HIGH</sub> minimum value in <a href="#">Table 4</a> as per CIN 2019120081</li></ul>