

ABS motorcycle braking chip

The SB0401 device is an antilock brake controller designed for use in harsh motorcycle environments.

It has two high-current low-side drivers for use with solenoid valves, two configurable wheel speed sense inputs capable of handling active sensors, and high-side gate drivers for controlling two external N-channel MOSFETs for use with a pump motor and master relay for solenoid coil. Along with this main functionality, the SB0401 also has a warning lamp driver and a K-line transceiver. The SB0401 boosts an internal charge pump allowing the high-side drivers to use inexpensive N-channel MOSFETs. The digital I/O pins can be configured for both 5.0 V and 3.3 V levels for easy connection to any microprocessor. The SB0401 uses standard SPI protocol for communication.

The SB0401 is a solution for ABS braking application, and is powered by SMARTMOS technology.

Features

- Two PWMed valves driver
- High-side pre-driver for valves protection
- Two wheel speed sensor interfaces (active)
- Dual vehicle speed outputs
- Pump motor pre-driver
- 16 bit SPI interface with watchdog
- K-line interface
- Warning lamp driver
- Die temperature warning
- Supervision

33SB0401

MOTORCYCLE BRAKING CHIP

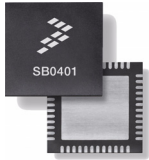

ES SUFFIX
48-PIN QFN-EP
98ASA00620D

Applications

- Motorcycle braking on one wheel

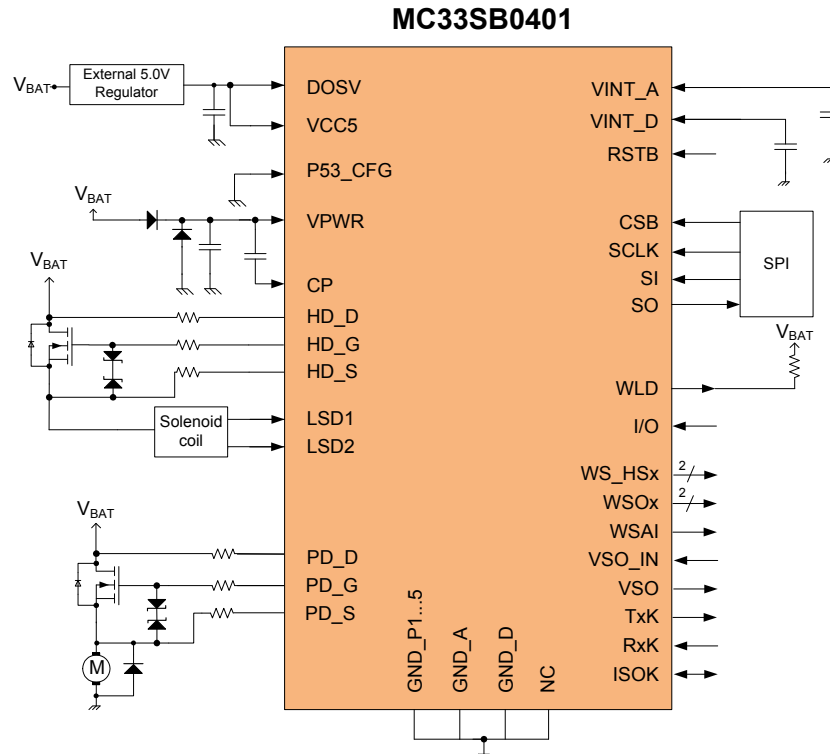

Figure 1. SB0401 simplified application diagram

* This document contains certain information on a new product. Specifications and information herein are subject to change without notice.

Table 1. Orderable part variations

Part number	Notes	Temperature (T _A)	Package	Description
MC33SB0401ES	(1)	-40 °C to 125 °C	7 x 7 x 0.9, 48-Pin QFN Exposed Pad, with 0.5 mm pitch, and a 5.6 x 5.6 exposed pad	<ul style="list-style-type: none"> • Two PWMed valves control • Safe switch control • Two wheel speed sensors • Pump motor control • ISO K-line interface • One warning lamp

Notes

1. To order parts in Tape & Reel, add the R2 suffix to the part number.

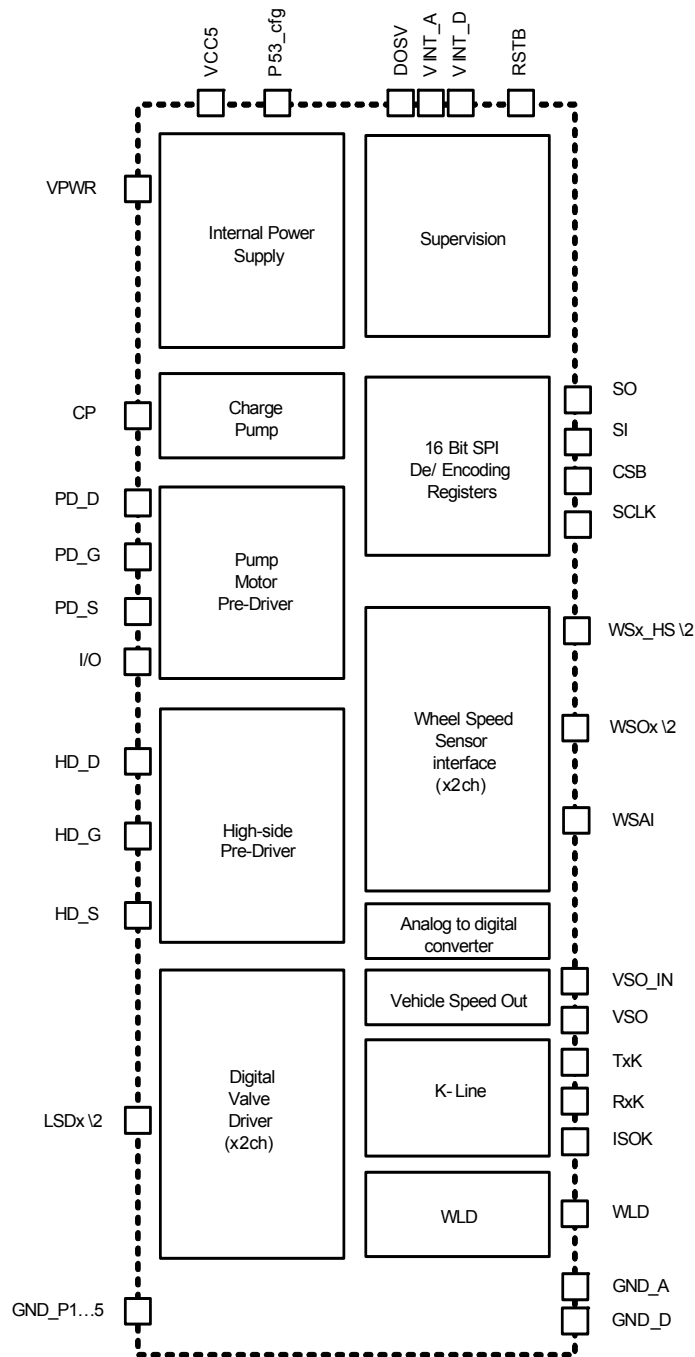

Figure 2. SB0401 simplified block diagram

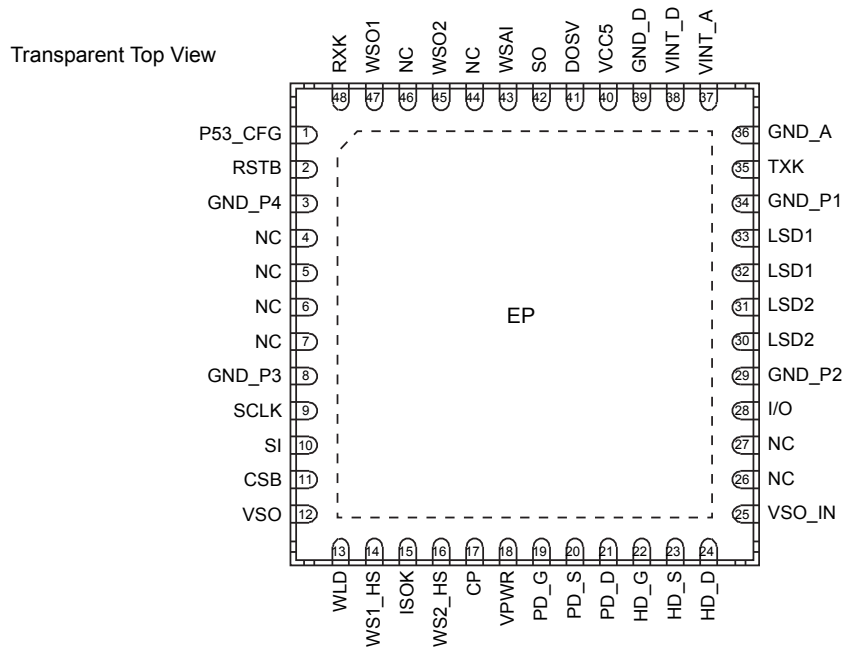

Figure 3. SB0401 48-Pin QFN-EP pinout diagram

Table 2. SB0401 pin definitions

Pin number	Pin name	Pin function
1	P53_CFG	Supply
2	RSTB	Reset
3	GND_P4	Supply
4	NC	
5	NC	
6	NC	
7	NC	
8	GND_P3	Supply
9	SCLK	SPI
10	SI	SPI
11	CSB	SPI
12	VSO	Vehicle Speed Output
13	WLD	Warning Lamp Driver
14	WS1_HS	Wheel Speed Sensor Interface
15	ISOK	K-LINE
16	WS2_HS	Wheel Speed Sensor Interface
17	CP	Charge Pump
18	VPWR	Supply
19	PD_G	Motor Pump Driver
20	PD_S	Motor Pump Driver
21	PD_D	Motor Pump Driver
22	HD_G	High-side Driver for Valve's Fail Safe FET
23	HD_S	High-side Driver for Valve's Fail Safe FET
24	HD_D	High-side Driver for Valve's Fail Safe FET
25	VSO_IN	Digital Input of VSO

Pin number	Pin name	Pin function
28	I/O	General I/O
29	GND_P2	Supply
30, 31	LSD2	Low-side Driver for Valves
32, 33	LSD1	Low-side Driver for Valves
34	GND_P1	Supply
35	TxK	K-LINE
36	GND_A	Supply
37	VINT_A	Internal Function
38	VINT_D	Internal Function
39	GND_D	Supply
40	VCC5	Supply
41	DOSV	Supply
42	SO	SPI
43	WSAI	Wheel Speed Sensor Interface
44, 46	NC	Not connected
45	WSO2	Wheel Speed Sensor Interface
47	WSO1	Wheel Speed Sensor Interface
48	RxK	K-LINE
4, 5, 6, 7, 26, 27	NC	Not connected
Exposed pad	GND_P5	Supply

Table 3. Key parameters

Characteristics noted under conditions $6.0\text{ V} \leq V_{PWR} \leq 20\text{ V}$, $4.75\text{ V} \leq V_{CC5} \leq 5.25\text{ V}$, $3.13\text{ V} \leq V_{DOSV} \leq 5.25\text{ V}$, $-40\text{ }^\circ\text{C} \leq T_J \leq 150\text{ }^\circ\text{C}$, $GND = 0\text{ V}$, unless otherwise noted.

Symbol	Characteristic	Typ.	Unit	Notes
--------	----------------	------	------	-------

VPWR current consumptions

I_{QVPWR}	Sleep mode measured at $V_{PWR} = 14\text{ V}$	3.0	μA	
I_{VPWR}	Operating mode	10	mA	

VCC5 current consumptions

I_{VCC5}	Operating mode	10	mA	
------------	----------------	----	----	--

Timings

LF_PWM	Output PWM frequency <ul style="list-style-type: none"> • LF_PWM_12 = 111 • LF_PWM_12 = 110 • LF_PWM_12 = 101 • LF_PWM_12 = 100 • LF_PWM_12 = 000 (default) • LF_PWM_12 = 011 • LF_PWM_12 = 001 • LF_PWM_12 = 010 	3.0 3.2 3.4 3.6 3.9 4.2 4.5 5.0	kHz	
0000 0000 0000 0001 ... 1111 1110 1111 1111	PWM Duty cycle Programming (8bits)	OFF 0.39 ... 99.61 ON	%	

Revision	Date	Description of changes
2.0	8/2016	• Added revision history table.