

## Features

- Low Quiescent Current: 5 $\mu$ A
- Operating Voltage Range: 2.0V~7.0V
- Low Dropout Voltage: 150mV@150mA
- Output Voltage: 1.2~ 5.0V
- High Accuracy:  $\pm 2\%$ (Typ.)
- High Ripple Rejection: 65dB@1kHz
- TTL-Logic-Controlled Shutdown Input
- Excellent Line and Load Transient Response
- Built-in Current Limiter, Short-Circuit Protection
- Epoxy Meets UL 94 V-0 Flammability Rating
- Halogen Free. "Green" Device (Note 1)
- Lead Free Finish/RoHS Compliant ("P" Suffix designates RoHS Compliant. See ordering information)

## Applications

- Cellular and Smart Phones
- Radio Control Systems
- Laptop, Palmtops and PDAs
- Digital Still and Video Cameras
- MP3,MP4 Player
- Battery-Powered Equipment

## Description

The MC6230 series are a group of positive voltage regulators manufactured by CMOS technologies with high ripple rejection, ultra-low noise, low power consumption and low dropout voltage, which can prolong battery life in portable electronics. The MC6230 series work with low-ESR ceramic capacitors, reducing the amount of board space necessary for power applications. The MC6230 series consume less than 0.1 $\mu$ A in shutdown mode and have fast turn-on time less than 50 $\mu$ S. The series are very suitable for the battery-powered equipments, such as RF applications and other systems requiring a quiet voltage source.

MCC Part Number	Device Marking
MC6230-1.2	9VBM
MC6230-1.5	B9qYM
MC6230-1.8	9VKM
MC6230-2.5	B9vYM
MC6230-2.8	9VXM
MC6230-3.0	B9zYM
MC6230-3.3	9A2M
MC6230-3.6	9A5M

### Note:

1. Halogen free "Green" products are defined as those which contain <900ppm bromine, <900ppm chlorine (<1500ppm total Br + Cl) and <1000ppm antimony compounds.

# Low Consumption Current High PSRR 300mA CMOS Voltage Regulators

## SOT23-5L

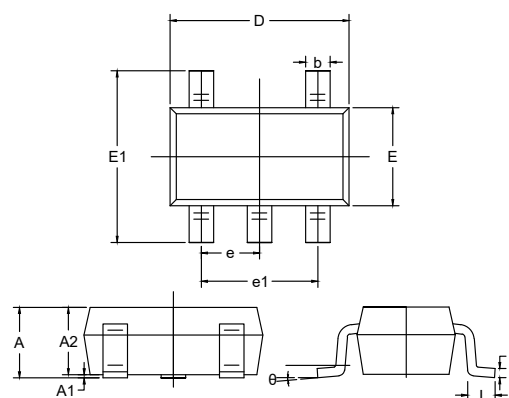

DIM	INCHES		MM		NOTE
	MIN	MAX	MIN	MAX	
A	0.041	0.049	1.05	1.25	
A1	0.000	0.004	0.00	0.10	
A2	0.041	0.045	1.05	1.15	
b	0.012	0.020	0.30	0.50	
c	0.004	0.008	0.10	0.20	
D	0.111	0.119	2.82	3.02	
E	0.059	0.067	1.50	1.70	
E1	0.104	0.116	2.65	2.95	
e	0.037(BSC)		0.950(BSC)		
e1	0.071	0.079	1.80	2.00	
L	0.012	0.024	0.30	0.60	
$\theta$	0°	8°	0°	8°	

### Suggested Solder Pad Layout

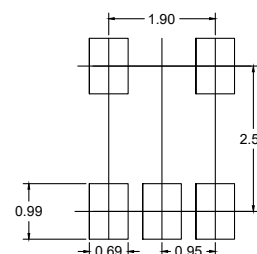

### Functional Block Diagram

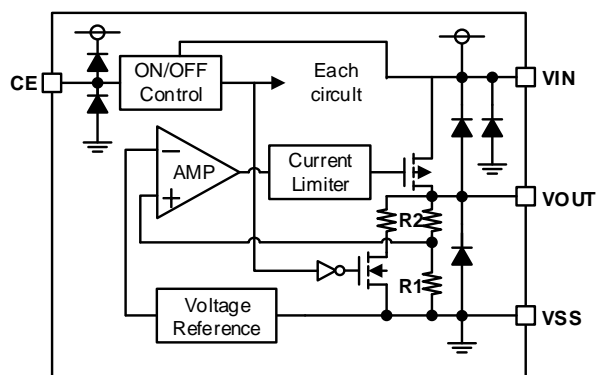

### Pin Configuration and Functions (Top View)

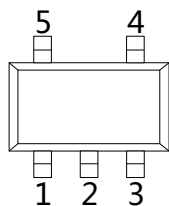

Number	Name	Function
1	$V_{IN}$	Power Input Pin
2	$V_{SS}$	Ground
3	CE	Chip Enable Pin
4	NC	No Connection
5	$V_{OUT}$	Output Pin

### Typical Application Circuit

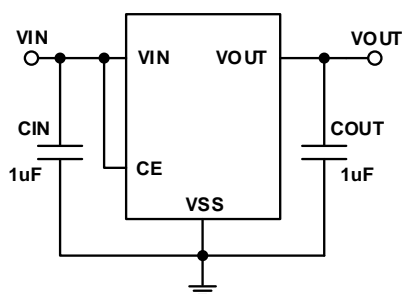

## Absolute Maximum Ratings

- Input Voltage:  $V_{SS}-0.3V \sim V_{SS}+8V$
- Output Voltage:  $V_{SS}-0.3V \sim V_{IN}+0.3V$
- Output Current: 300mA
- Power Dissipation: 500mW
- Operating Free Air Temperature Range:  $-40\sim+85^{\circ}C$
- Operating Junction Temperature Range:  $-40\sim+125^{\circ}C$
- Storage Temperature Range:  $-40\sim+125^{\circ}C$
- Lead Temperature & Time:  $260^{\circ}C, 10s$

## Electrical Characteristics

( $V_{IN}=V_{OUT}+1V, C_{IN}=C_{OUT}=1\mu F, T_A=25^{\circ}C$ , unless otherwise specified)

Parameter	Symbol	Conditions	Min.	Typ.	Max.	Units
Output Voltage	$V_{OUT(E)}^{(1)}$	$I_{OUT}=1mA$	$V_{OUT} * 0.98$	$V_{OUT}$	$V_{OUT} * 1.02$	V
Supply Current	$I_{SS}$	$I_{OUT}=0$		5	10	$\mu A$
Standby Current	$I_{STBY}$	$CE = V_{SS}$			0.1	$\mu A$
Output Current	$I_{OUT}$	—	300			mA
Dropout Voltage <sup>(2)</sup>	$V_{dif}$	$I_{OUT} = 150mA$ $V_{OUT} \geq 3.0V$		150		mV
Load Regulation	$\Delta V_{OUT}$	$V_{IN} = V_{OUT} + 1V,$ $1mA \leq I_{OUT} \leq 100mA$		10		mV
Line Regulation	$\frac{\Delta V_{OUT}}{V_{OUT} \times \Delta V_{IN}}$	$I_{OUT} = 10mA$ $V_{OUT} + 1V \leq V_{IN} \leq 6V$		0.01	0.2	%/V
Output Voltage Temperature Characteristics	$\frac{\Delta V_{OUT}}{\Delta T \times V_{OUT}}$	$I_{OUT} = 10mA$ $-40 \leq T \leq +85$		100		ppm
Current Limit	$I_{LIM}$	$V_{OUT} = 0.5 \times V_{OUT(Normal)}$ $V_{IN} = V_{OUT} + 1V$	350	750		mA
Short Current	$I_{Short}$	$V_{OUT} = V_{SS}$		50		mA
Input Voltage	$V_{IN}$	—	2.0		7.0	V
Power Supply Rejection Rate	1kHz	PSRR	$I_{OUT}=50mA$		65	dB
	10kHz				50	
CE "High" Voltage	$V_{CE} "H"$		1.5		$V_{IN}$	V
CE "Low" Voltage	$V_{CE} "L"$				0.3	V

Note:

1.  $V_{OUT(E)}$  : Effective Output Voltage ( i.e. The output voltage when  $V_{IN}=(V_{OUT} + 1.0V)$  and maintain a certain  $I_{OUT}$  Value).
2.  $V_{dif}$  : The Difference Of Output Voltage And Input Voltage When Input Voltage Is Decreased Gradually Till Output Voltage Equals To 98% Of  $V_{OUT(E)}$ .

**Curve Characteristics**

**Output Characteristics**

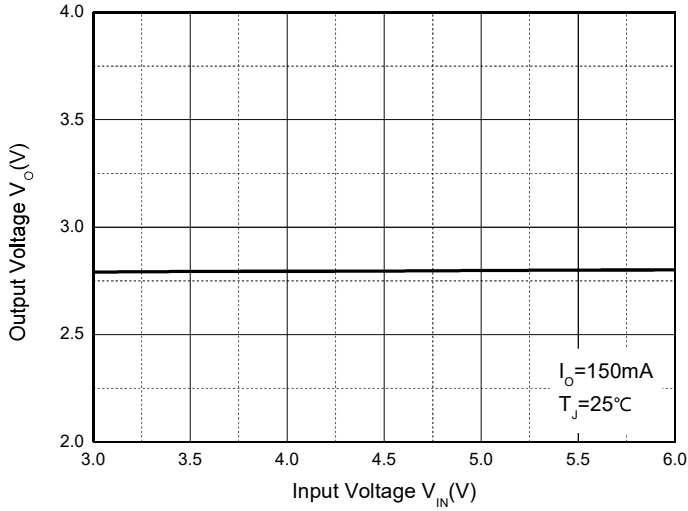

**Output Voltage vs. Temperature**

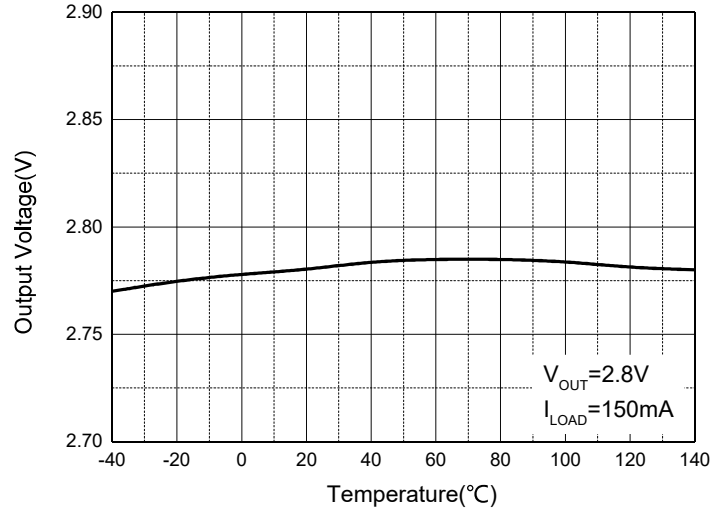

**Quiescent Current**

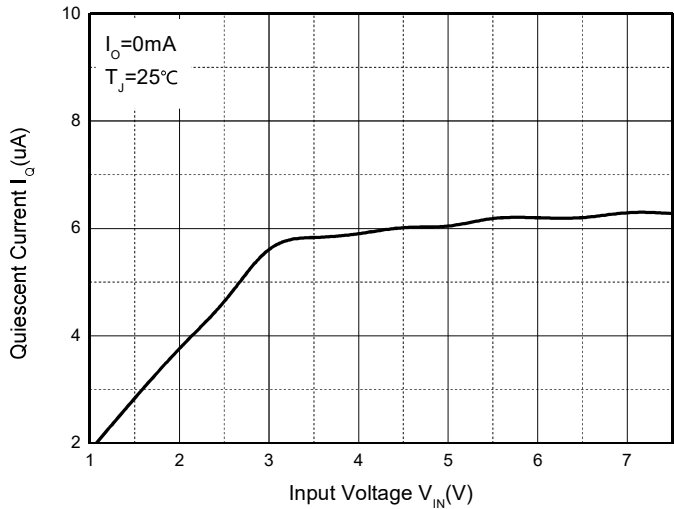

**Current Cut-off Grid Voltage**

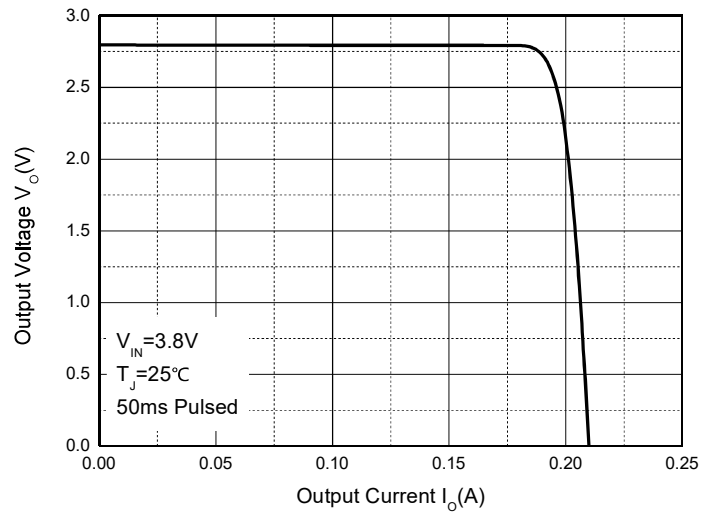

**Dropout Voltage vs. Load Current**

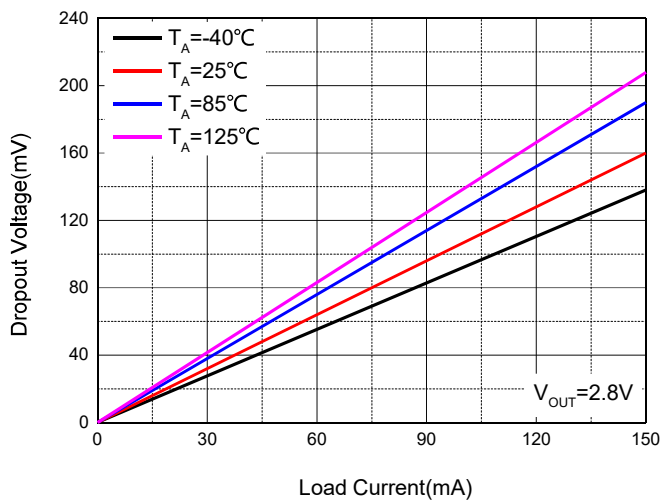

**PSRR vs. Frequency**

