

MC74LVX4051

Analog Multiplexer/ Demultiplexer High-Performance Silicon-Gate CMOS

The MC74LVX4051 utilizes silicon-gate CMOS technology to achieve fast propagation delays, low ON resistances, and low leakage currents. This analog multiplexer/demultiplexer controls analog voltages that may vary across the complete power supply range (from V_{CC} to V_{EE}).

The LVX4051 is similar in pinout to the LVX8051, the HC4051A, and the metal-gate MC14051B. The Channel-Select inputs determine which one of the Analog Inputs/Outputs is to be connected, by means of an analog switch, to the Common Output/Input. When the Enable pin is HIGH, all analog switches are turned off.

The Channel-Select and Enable inputs are compatible with standard CMOS outputs. These inputs are overvoltage tolerant (OVT) for level translation from 6.0 V down to 3.0 V.

This device has been designed so the ON resistance (R_{ON}) is more linear over input voltage than the R_{ON} of metal-gate CMOS analog switches and High-Speed CMOS analog switches.

Features

- Fast Switching and Propagation Speeds
- Low Crosstalk Between Switches
- Analog Power Supply Range ($V_{CC} - V_{EE}$) = -3.0 V to +3.0 V
- Digital (Control) Power Supply Range ($V_{CC} - GND$) = 2.5 to 6.0 V
- Improved Linearity and Lower ON Resistance Than Metal-Gate, HSL, or VHC Counterparts
- Low Noise
- Designed to Operate on a Single Supply with $V_{EE} = GND$, or Using Split Supplies up to ± 3.0 V
- Break-Before-Make Circuitry
- These Devices are Pb-Free and are RoHS Compliant



ON Semiconductor®

<http://onsemi.com>



QFN16
MN SUFFIX
CASE 485AW

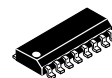

SOIC-16
D SUFFIX
CASE 751B



TSSOP-16
DT SUFFIX
CASE 948F

MARKING DIAGRAMS

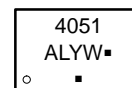

QFN16

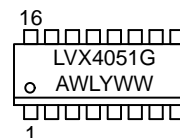

SOIC-16

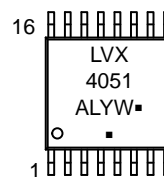

TSSOP-16

LVX4051 = Specific Device Code
A = Assembly Location
WL, L = Wafer Lot
Y = Year
WW, W = Work Week
G or ■ = Pb-Free Package

(Note: Microdot may be in either location)

ORDERING INFORMATION

See detailed ordering and shipping information in the package dimensions section on page 2 of this data sheet.

MC74LVX4051

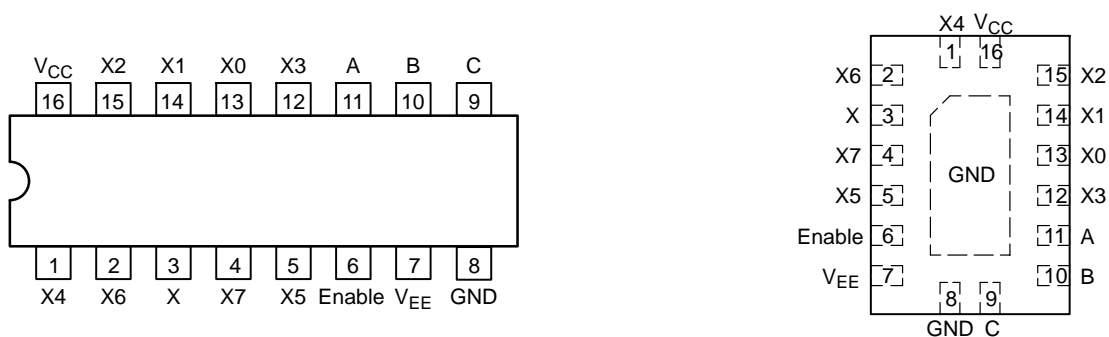

Figure 1. Pin Connection Diagrams
(Top View)

FUNCTION TABLE

Control Inputs				ON Channels
Enable	Select			
	C	B	A	
L	L	L	L	X0
L	L	L	H	X1
L	L	H	L	X2
L	L	H	H	X3
L	H	L	L	X4
L	H	L	H	X5
L	H	H	L	X6
L	H	H	H	X7
H	X	X	X	NONE

X = Don't Care

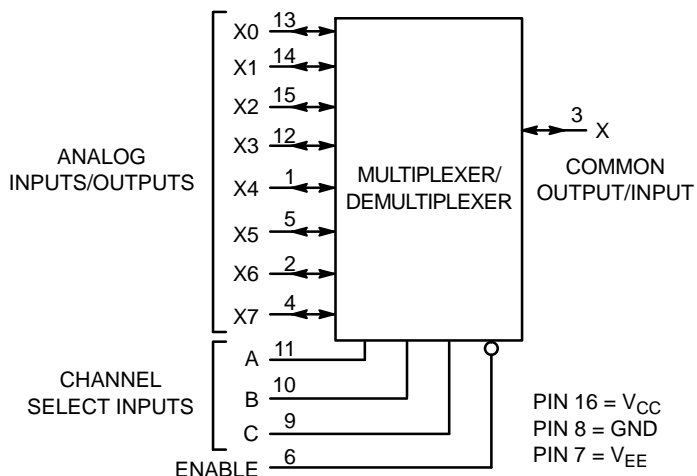

Figure 2. Logic Diagram
Single-Pole, 8-Position Plus Common Off

ORDERING INFORMATION

Device	Package	Shipping [†]
MC74LVX4051DG	SOIC-16 (Pb-Free)	48 Units / Rail
MC74LVX4051DR2G	SOIC-16 (Pb-Free)	2500 / Tape & Reel
MC74LVX4051DTG	TSSOP-16 (Pb-Free)	96 Units / Rail
MC74LVX4051DTR2G	TSSOP-16 (Pb-Free)	2500 / Tape & Reel
MC74LVX4051MNTWG	QFN-16 (Pb-Free)	3000 / Tape & Reel

[†]For information on tape and reel specifications, including part orientation and tape sizes, please refer to our Tape and Reel Packaging Specifications Brochure, BRD8011/D.

MC74LVX4051

MAXIMUM RATINGS

Symbol	Parameter	Value	Unit
V_{EE}	Negative DC Supply Voltage (Referenced to GND)	-7.0 to +0.5	V
V_{CC}	Positive DC Supply Voltage (Referenced to GND) (Referenced to V_{EE})	0.5 to + 7.0 -0.5 to + 7.0	V
V_{IS}	Analog Input Voltage	$V_{EE} - 0.5$ to $V_{CC} + 0.5$	V
V_{IN}	Digital Input Voltage (Referenced to GND)	-0.5 to 7.0	V
I	DC Current, Into or Out of Any Pin	±50	mA
T_{STG}	Storage Temperature Range	-65 to +150	°C
T_L	Lead Temperature, 1 mm from Case for 10 Seconds	260	°C
T_J	Junction Temperature under Bias	+150	°C
θ_{JA}	Thermal Resistance	SOIC 143 TSSOP 164	°C/W
P_D	Power Dissipation in Still Air,	SOIC 500 TSSOP 450	mW
MSL	Moisture Sensitivity	Level 1	
F_R	Flammability Rating	Oxygen Index: 30% – 35% UL 94-V0 @ 0.125 in	
V_{ESD}	ESD Withstand Voltage	Human Body Model (Note 1) > 2000 Machine Model (Note 2) > 200 Charged Device Model (Note 3) > 1000	V
$I_{LATCHUP}$	Latchup Performance	Above V_{CC} and Below GND at 125°C (Note 4)	±300 mA

Stresses exceeding those listed in the Maximum Ratings table may damage the device. If any of these limits are exceeded, device functionality should not be assumed, damage may occur and reliability may be affected.

1. Tested to EIA/JESD22-A114-A.
2. Tested to EIA/JESD22-A115-A.
3. Tested to JESD22-C101-A.
4. Tested to EIA/JESD78.

RECOMMENDED OPERATING CONDITIONS

Symbol	Parameter	Min	Max	Unit
V_{EE}	Negative DC Supply Voltage (Referenced to GND)	-6.0	GND	V
V_{CC}	Positive DC Supply Voltage (Referenced to GND) (Referenced to V_{EE})	2.5 2.5	6.0 6.0	V
V_{IS}	Analog Input Voltage	V_{EE}	V_{CC}	V
V_{IN}	Digital Input Voltage (Note 5) (Referenced to GND)	0	6.0	V
T_A	Operating Temperature Range, All Package Types	-55	125	°C
t_r, t_f	Input Rise/Fall Time (Channel Select or Enable Inputs) $V_{CC} = 3.0\text{ V} \pm 0.3\text{ V}$ $V_{CC} = 5.0\text{ V} \pm 0.5\text{ V}$	0 0	100 20	ns/V

5. Unused inputs may not be left open. All inputs must be tied to a high-logic voltage level or a low-logic input voltage level.

DEVICE JUNCTION TEMPERATURE VERSUS TIME TO 0.1% BOND FAILURES

Junction Temperature °C	Time, Hours	Time, Years
80	1,032,200	117.8
90	419,300	47.9
100	178,700	20.4
110	79,600	9.4
120	37,000	4.2
130	17,800	2.0
140	8,900	1.0

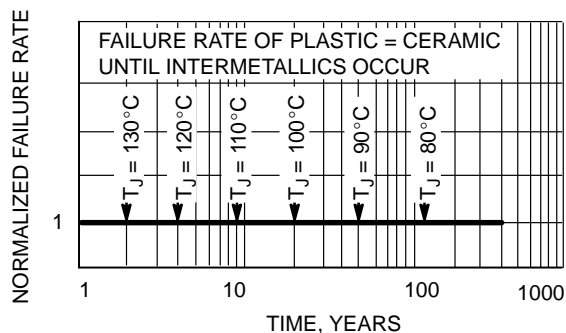

Figure 3. Failure Rate vs. Time Junction Temperature

MC74LVX4051

DC CHARACTERISTICS – Digital Section (Voltages Referenced to GND)

Symbol	Parameter	Condition	V _{CC} V	Guaranteed Limit			Unit
				-55 to 25°C	≤85°C	≤125°C	
V _{IH}	Minimum High-Level Input Voltage, Channel-Select or Enable Inputs		2.5	1.90	1.90	1.90	V
			3.0	2.10	2.10	2.10	
			4.5	3.15	3.15	3.15	
			6.0	4.2	4.2	4.2	
V _{IL}	Maximum Low-Level Input Voltage, Channel-Select or Enable Inputs		2.5	0.6	0.6	0.6	V
			3.0	0.9	0.9	0.9	
			4.5	1.35	1.35	1.35	
			6.0	1.8	1.8	1.8	
I _{IN}	Maximum Input Leakage Current, Channel-Select or Enable Inputs	V _{IN} = 6.0 or GND	0 V to 6.0 V	±0.1	±1.0	±1.0	μA
I _{CC}	Maximum Quiescent Supply Current (per Package)	Channel Select, Enable and V _{IS} = V _{CC} or GND	6.0	4.0	40	80	μA

DC ELECTRICAL CHARACTERISTICS – Analog Section

Symbol	Parameter	Test Conditions	V _{CC} V	V _{EE} V	Guaranteed Limit			Unit
					-55 to 25°C	≤85°C	≤125°C	
R _{ON}	Maximum "ON" Resistance	V _{IN} = V _{IL} or V _{IH} V _{IS} = ½ (V _{CC} - V _{EE}) I _S = 2.0 mA (Figure 4)	3.0	0	86	108	120	Ω
			4.5	0	37	46	55	
			3.0	-3.0	26	33	37	
ΔR _{ON}	Maximum Difference in "ON" Resistance Between Any Two Channels in the Same Package	V _{IN} = V _{IL} or V _{IH} V _{IS} = ½ (V _{CC} - V _{EE}) I _S = 2.0 mA	3.0	0	15	20	20	Ω
			4.5	0	13	18	18	
			3.0	-3.0	10	15	15	
I _{off}	Maximum Off-Channel Leakage Current, Any One Channel	V _{in} = V _{IL} or V _{IH} ; V _{IO} = V _{CC} or GND; Switch Off (Figure 3)	5.5 +3.0	0 -3.0	0.1 0.1	0.5 0.5	1.0 1.0	μA
	Maximum Off-Channel Leakage Current, Common Channel	V _{in} = V _{IL} or V _{IH} ; V _{IO} = V _{CC} or GND; Switch Off (Figure 4)	5.5 +3.0	0 -3.0	0.2 0.2	2.0 2.0	4.0 4.0	
I _{on}	Maximum On-Channel Leakage Current, Channel-to-Channel	V _{in} = V _{IL} or V _{IH} ; Switch-to-Switch = V _{CC} or GND; (Figure 5)	5.5 +3.0	0 -3.0	0.2 0.2	2.0 2.0	4.0 4.0	μA

AC CHARACTERISTICS (Input t_r = t_f = 3 ns)

Symbol	Parameter	Test Conditions	V _{CC} V	V _{EE} V	Guaranteed Limit				Unit
					-55 to 25°C		≤85°C	≤125°C	
					Min	Typ*			
t _{BBM}	Minimum Break-Before-Make Time	V _{IN} = V _{IL} or V _{IH} V _{IS} = V _{CC} R _L = 300 Ω, C _L = 35 pF (Figures 12 and 13)	3.0	0.0	1.0	6.5	-	-	ns
			4.5	0.0	1.0	5.0	-	-	
			3.0	-3.0	1.0	3.5	-	-	

*Typical Characteristics are at 25°C.

MC74LVX4051

AC CHARACTERISTICS ($C_L = 50$ pF, Input $t_r = t_f = 3$ ns)

Symbol	Parameter	V_{CC} V	V_{EE} V	Guaranteed Limit						Unit	
				-55 to 25°C			≤85°C		≤125°C		
				Min	Typ	Max	Min	Max	Min		Max
t_{PLH} , t_{PHL}	Maximum Propagation Delay, Channel-Select to Analog Output (Figures 16 and 17)	2.5	0			40		45		50	ns
		3.0	0			28		30		35	
		4.5	0			23		25		30	
		3.0	-3.0			23		25		28	
t_{PLZ} , t_{PHZ}	Maximum Propagation Delay, Enable to Analog Output (Fig- ures 14 and 15)	2.5	0			40		45		50	ns
		3.0	0			28		30		35	
		4.5	0			23		25		30	
		3.0	-3.0			23		25		28	
t_{PZL} , t_{PZH}	Maximum Propagation Delay, Enable to Analog Output (Fig- ures 14 and 15)	2.5	0			40		45		50	ns
		3.0	0			28		30		35	
		4.5	0			23		25		30	
		3.0	-3.0			23		25		28	

		Typical @ 25°C, $V_{CC} = 5.0$ V, $V_{EE} = 0$ V			Unit
C_{PD}	Power Dissipation Capacitance (Figure 18) (Note 6)	45			pF
C_{IN}	Maximum Input Capacitance, Channel-Select or Enable Inputs	10			pF
$C_{I/O}$	Maximum Capacitance (All Switches Off)	Analog I/O		10	pF
		Common O/I		10	
		Feedthrough		1.0	

6. Used to determine the no-load dynamic power consumption: $P_D = C_{PD} V_{CC}^2 f + I_{CC} V_{CC}$.

ADDITIONAL APPLICATION CHARACTERISTICS (GND = 0 V)

Symbol	Parameter	Condition	V_{CC} V	V_{EE} V	Typ	Unit
					25°C	
BW	Maximum On-Channel Bandwidth or Minimum Frequency Response	$V_{IS} = \frac{1}{2} (V_{CC} - V_{EE})$ Ref and Test Attn = 10 dB Source Amplitude = 0 dB (Figure 7)	3.0	0.0	80	MHz
			4.5	0.0	80	
			6.0	0.0	80	
			3.0	-3.0	80	
V_{ISO}	Off-Channel Feedthrough Isolation	$f = 1$ MHz; $V_{IS} = \frac{1}{2} (V_{CC} - V_{EE})$ Adjust Network Analyzer output to 10 dBm on each output from the power splitter (Figures 8 and 9)	3.0	0.0	-70	dB
			4.5	0.0	-70	
			6.0	0.0	-70	
			3.0	-3.0	-70	
V_{ONL}	Maximum Feedthrough On Loss	$V_{IS} = \frac{1}{2} (V_{CC} - V_{EE})$ Adjust Network Analyzer output to 10 dBm on each output from the power splitter (Figure 11)	3.0	0.0	-2	dB
			4.5	0.0	-2	
			6.0	0.0	-2	
			3.0	-3.0	-2	
Q	Charge Injection	$V_{IN} = V_{CC}$ to V_{EE} , $f_{IS} = 1$ kHz, $t_r = t_f = 3$ ns $R_{IS} = 0 \Omega$, $C_L = 1000$ pF, $Q = C_L \cdot \Delta V_{OUT}$ (Figure 10)	5.0	0.0	9.0	pC
			3.0	-3.0	12	
THD	Total Harmonic Distortion THD + Noise	$f_{IS} = 1$ MHz, $R_L = 10$ K Ω , $C_L = 50$ pF, $V_{IS} = 5.0$ V _{PP} sine wave $V_{IS} = 6.0$ V _{PP} sine wave (Figure 19)	6.0	0.0	0.10	%
			3.0	-3.0	0.05	

MC74LVX4051

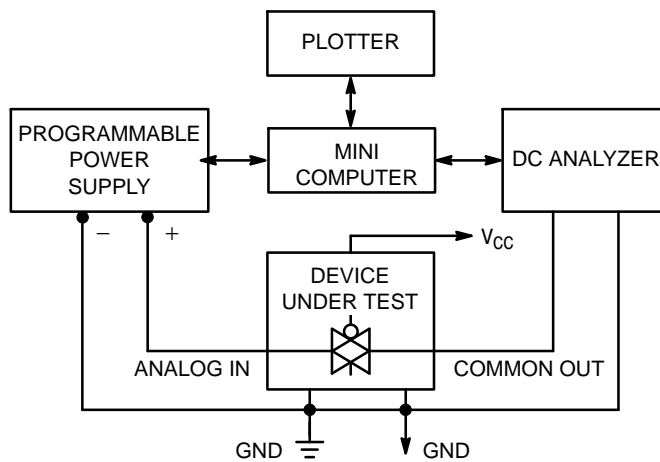

Figure 4. On Resistance, Test Set-Up

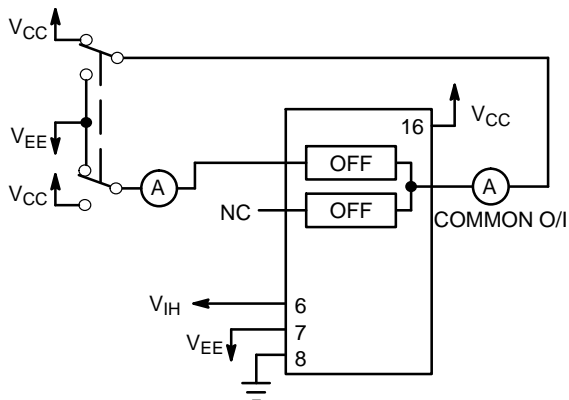

Figure 5. Maximum Off Channel Leakage Current, Any One Channel, Test Set-Up

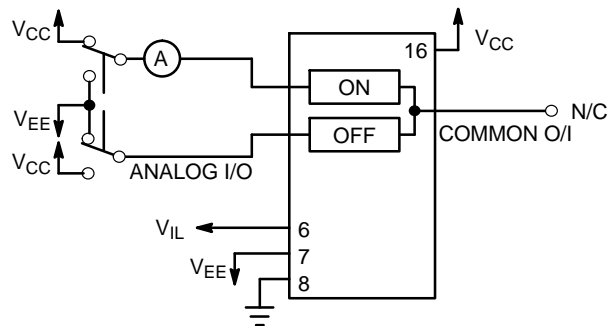

Figure 6. Maximum On Channel Leakage Current, Channel to Channel, Test Set-Up

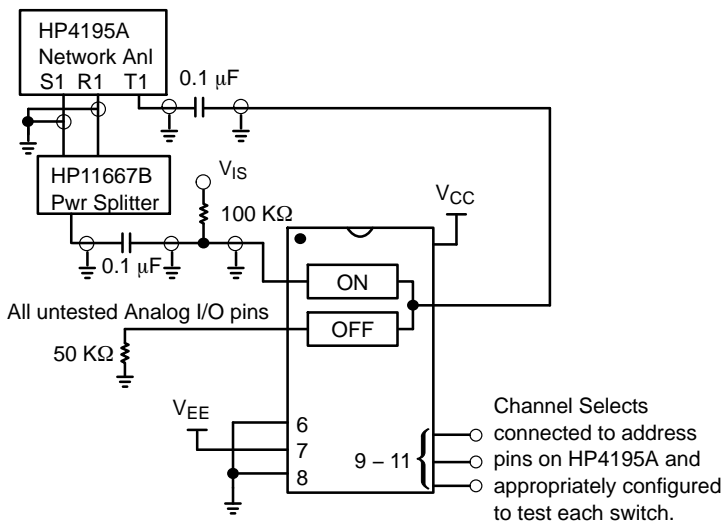
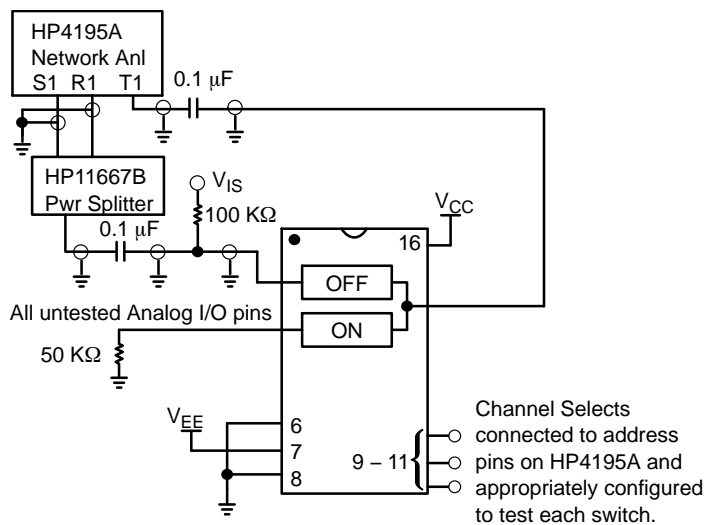

Figure 7. Maximum On Channel Bandwidth, Test Set-Up

MC74LVX4051



Config = Network
 Format = T/R (dB)
 CAL = Trans Cal
 Display = Rectan X - A + B
 Scale Ref = Auto Scale
 View = Off, Off, Off
 Trig = Cont Mode
 Source Amplitude = + 13 dB
 Reference Attenuation = 20 dB
 Test Attenuation = 0 dB

$$V_{ISO}(dB) = 20 \log (V_{T1}/V_{R1})$$

Figure 8. Maximum Off Channel Feedthrough Isolation, Test Set-Up

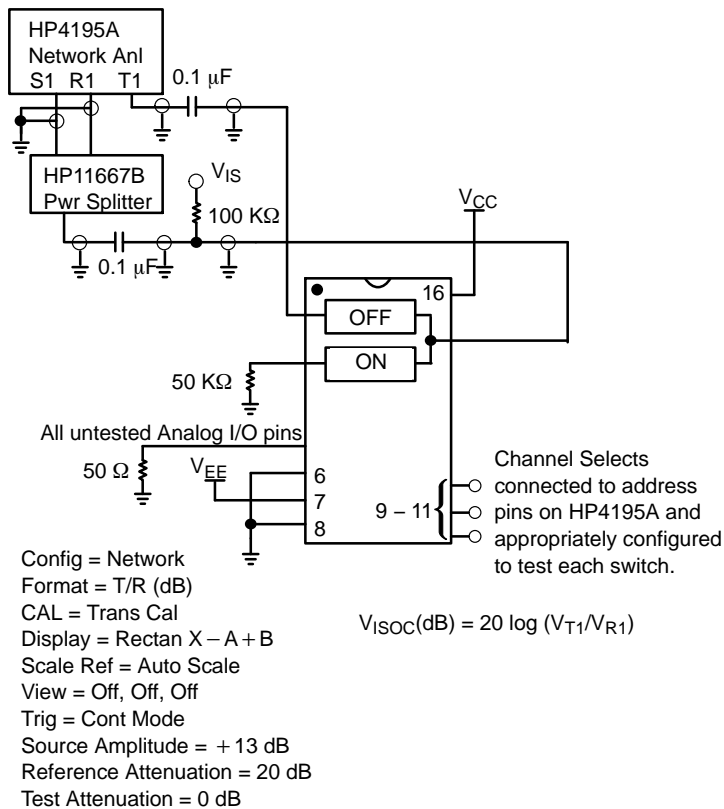

Config = Network
 Format = T/R (dB)
 CAL = Trans Cal
 Display = Rectan X - A + B
 Scale Ref = Auto Scale
 View = Off, Off, Off
 Trig = Cont Mode
 Source Amplitude = + 13 dB
 Reference Attenuation = 20 dB
 Test Attenuation = 0 dB

$$V_{ISOC}(dB) = 20 \log (V_{T1}/V_{R1})$$

Figure 9. Maximum Common-Channel Feedthrough Isolation, Test Set-Up

MC74LVX4051

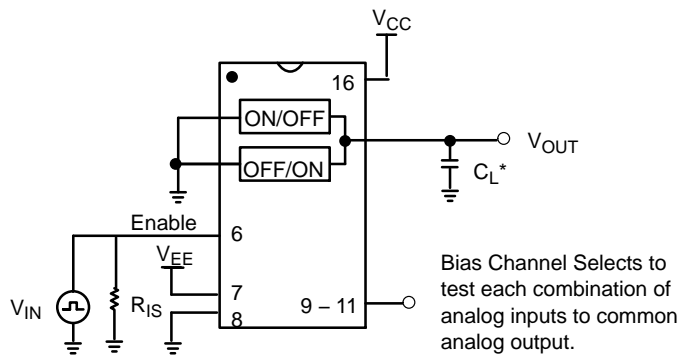

*Includes all probe and jig capacitance.

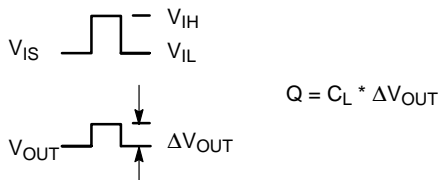

Figure 10. Charge Injection, Test Set-Up

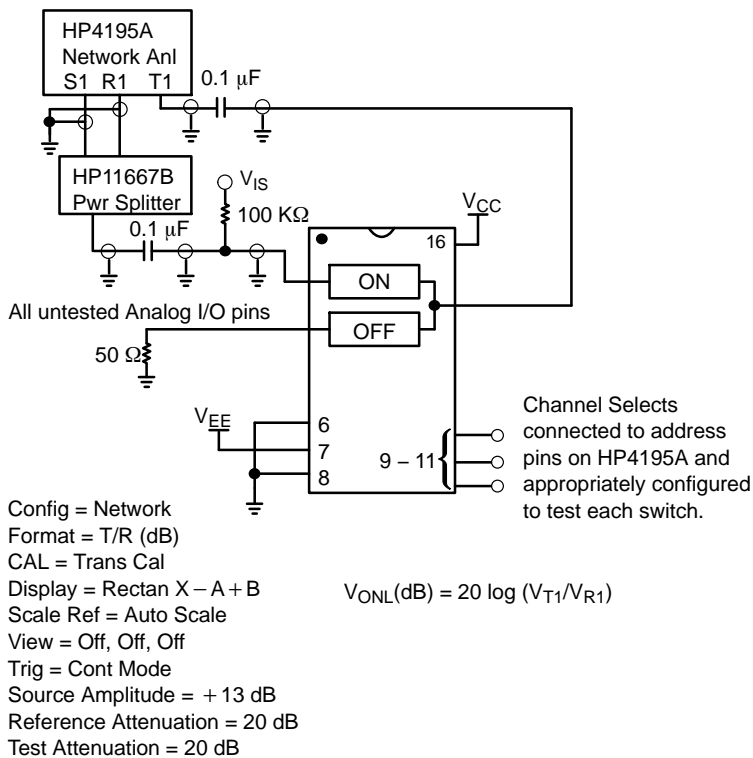

Figure 11. Maximum On Channel Feedthrough On Loss, Test Set-Up

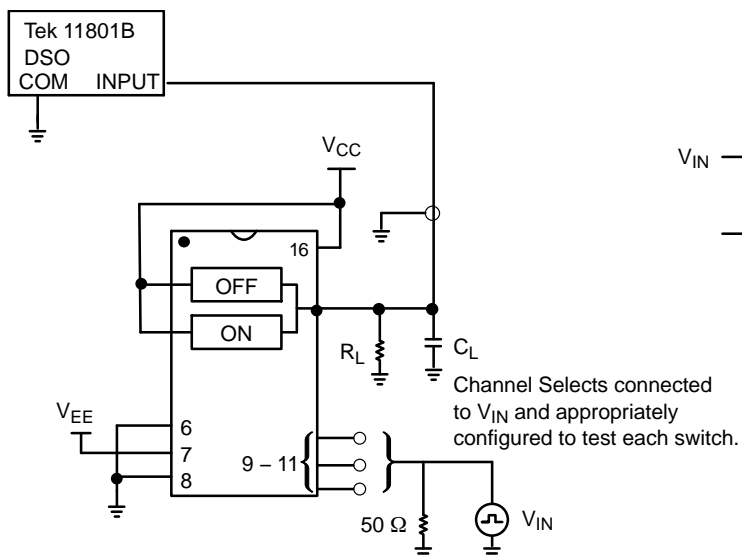

Figure 12. Break-Before-Make, Test Set-Up

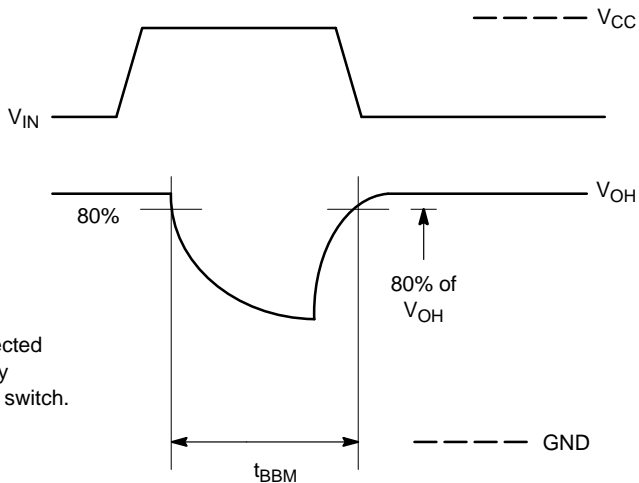

Figure 13. Break-Before-Make Time

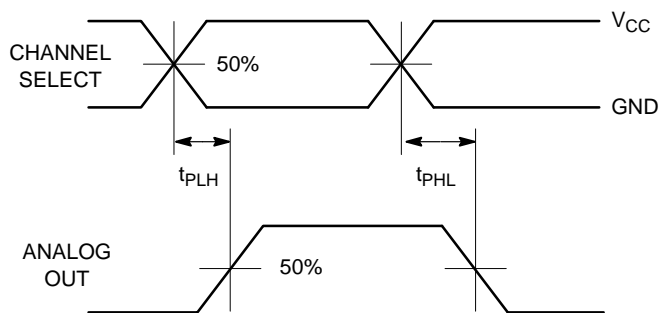
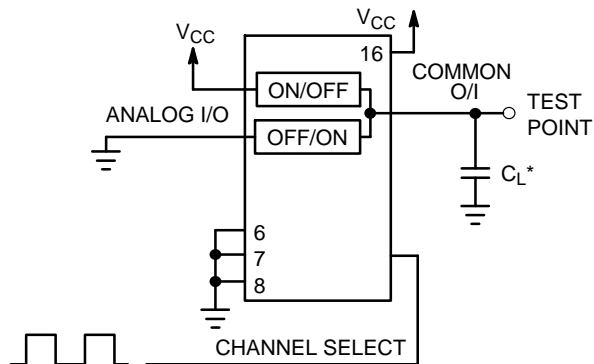

Figure 14. Propagation Delays, Channel Select to Analog Out



*Includes all probe and jig capacitance.

Figure 15. Propagation Delay, Test Set-Up Channel Select to Analog Out

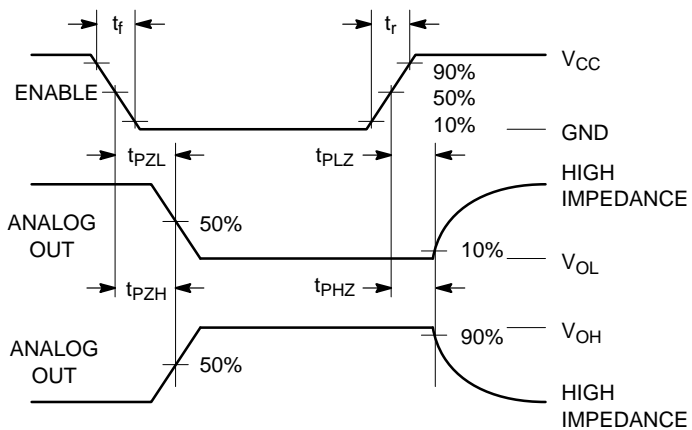

Figure 16. Propagation Delays, Enable to Analog Out

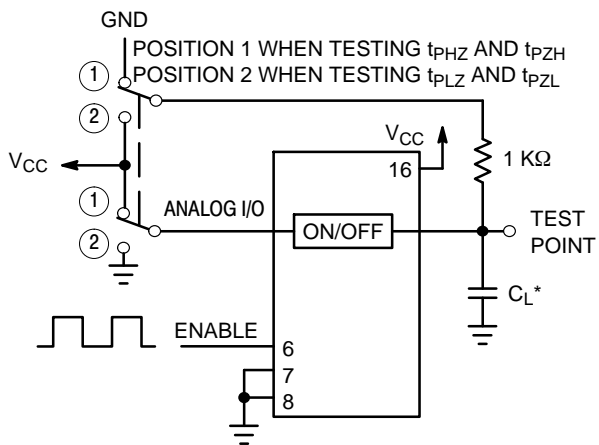

Figure 17. Propagation Delay, Test Set-Up Enable to Analog Out

MC74LVX4051

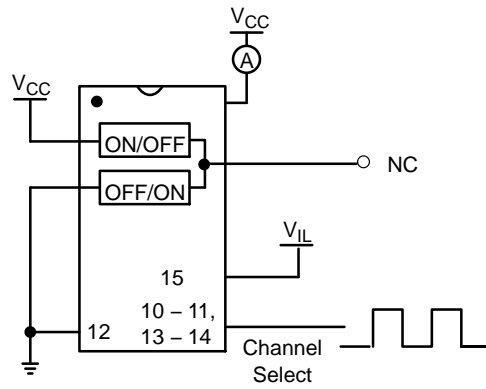

Figure 18. Power Dissipation Capacitance, Test Set-Up

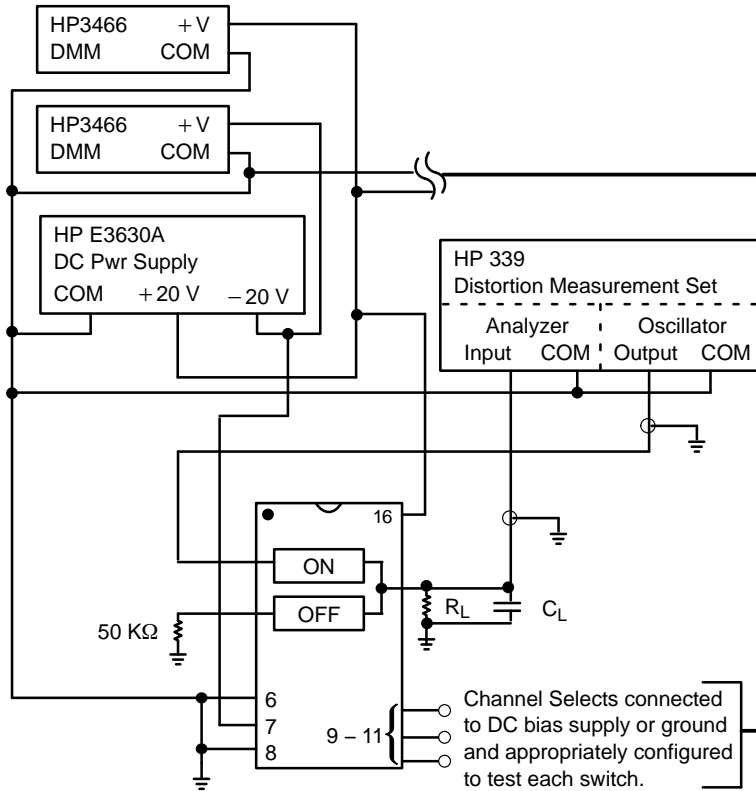

Figure 19. Total Harmonic Distortion, Test Set-Up

APPLICATIONS INFORMATION

The Channel Select and Enable control pins should be at V_{CC} or GND logic levels. V_{CC} being recognized as a logic high and GND being recognized as a logic low. In this example:

$$V_{CC} = +5 \text{ V} = \text{logic high}$$

$$GND = 0 \text{ V} = \text{logic low}$$

The maximum analog voltage swing is determined by the supply voltages V_{CC} and V_{EE} . The positive peak analog voltage should not exceed V_{CC} . Similarly, the negative peak analog voltage should not go below V_{EE} . In this example, the difference between V_{CC} and V_{EE} is five volts. Therefore, using the configuration of Figure 21, a maximum analog signal of five volts peak-to-peak can be controlled. Unused analog inputs/outputs may be left floating (i.e., not connected). However, tying unused analog inputs and

outputs to V_{CC} or GND through a low value resistor helps minimize crosstalk and feedthrough noise that may be picked up by an unused switch.

Although used here, balanced supplies are not a requirement. The only constraints on the power supplies are that:

$$V_{EE} - GND = 0 \text{ to } -6 \text{ volts}$$

$$V_{CC} - GND = 2.5 \text{ to } 6 \text{ volts}$$

$$V_{CC} - V_{EE} = 2.5 \text{ to } 6 \text{ volts}$$

$$\text{and } V_{EE} \leq GND$$

When voltage transients above V_{CC} and/or below V_{EE} are anticipated on the analog channels, external Germanium or Schottky diodes (D_x) are recommended as shown in Figure 22. These diodes should be able to absorb the maximum anticipated current surges during clipping.

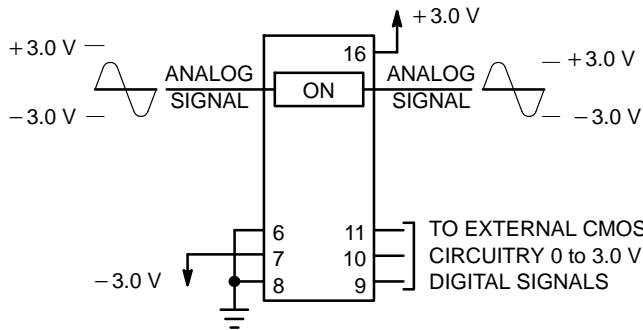

Figure 20. Application Example

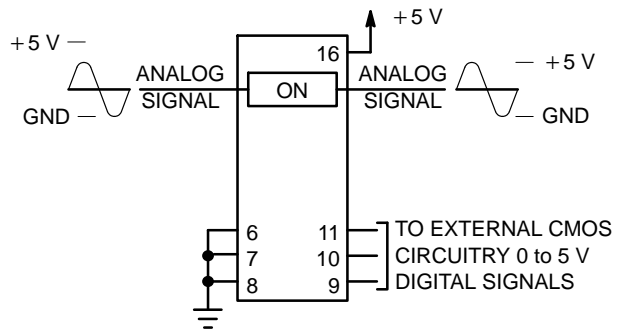

Figure 21. Application Example

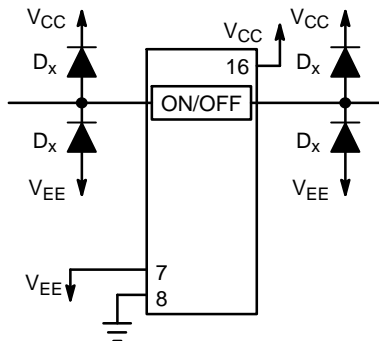

Figure 22. External Germanium or Schottky Clipping Diodes

MC74LVX4051

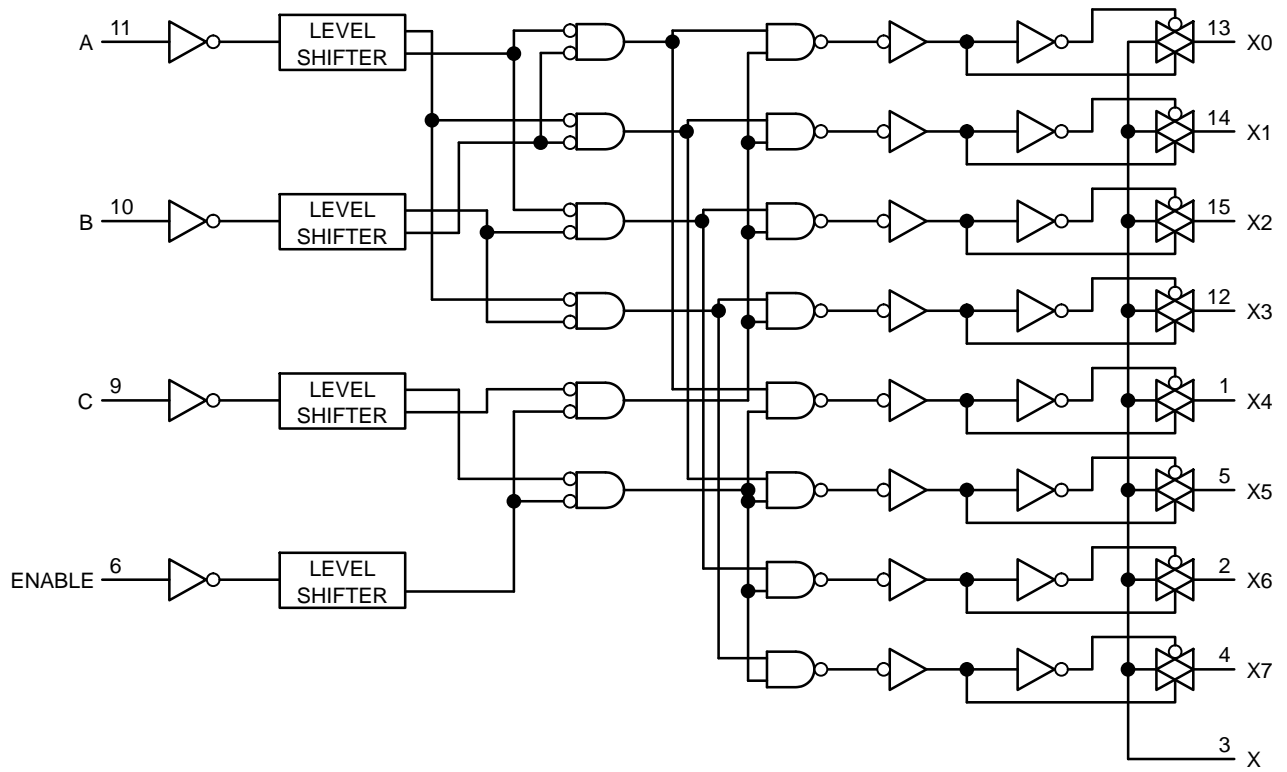

Figure 23. Function Diagram, LVX4051

MECHANICAL CASE OUTLINE

PACKAGE DIMENSIONS

ON Semiconductor®



SCALE 2:1

QFN16, 2.5x3.5, 0.5P
CASE 485AW-01
ISSUE 0

DATE 11 DEC 2008

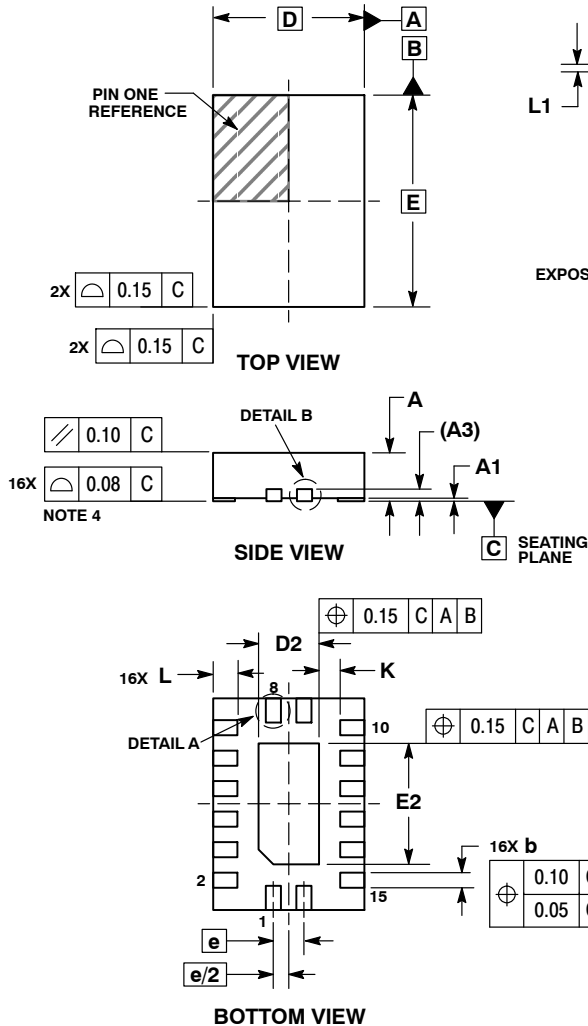

- NOTES:
1. DIMENSIONING AND TOLERANCING PER ASME Y14.5M, 1994.
 2. CONTROLLING DIMENSION: MILLIMETERS.
 3. DIMENSIONS b APPLIES TO PLATED TERMINAL AND IS MEASURED BETWEEN 0.15 AND 0.30 MM FROM TERMINAL.
 4. COPLANARITY APPLIES TO THE EXPOSED PAD AS WELL AS THE TERMINALS.

DIM	MILLIMETERS	
	MIN	MAX
A	0.80	1.00
A1	0.00	0.05
A3	0.20 REF	
b	0.20	0.30
D	2.50 BSC	
D2	0.85	1.15
E	3.50 BSC	
E2	1.85	2.15
e	0.50 BSC	
K	0.20	---
L	0.35	0.45
L1	---	0.15

GENERIC MARKING DIAGRAM*

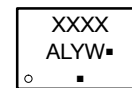

- XXXX = Specific Device Code
- A = Assembly Location
- L = Wafer Lot
- Y = Year
- W = Work Week
- = Pb-Free Package

(Note: Microdot may be in either location)

*This information is generic. Please refer to device data sheet for actual part marking. Pb-Free indicator, "G" or microdot "▪", may or may not be present.

SOLDERING FOOTPRINT*

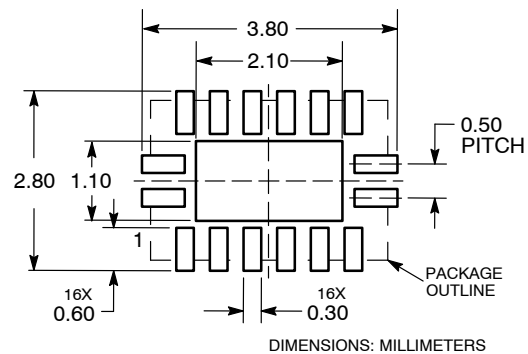

*For additional information on our Pb-Free strategy and soldering details, please download the ON Semiconductor Soldering and Mounting Techniques Reference Manual, SOLDERRM/D.

DOCUMENT NUMBER:	98AON36347E	Electronic versions are uncontrolled except when accessed directly from the Document Repository. Printed versions are uncontrolled except when stamped "CONTROLLED COPY" in red.
DESCRIPTION:	QFN16, 2.5X3.5, 0.5P	PAGE 1 OF 1

ON Semiconductor and ON are trademarks of Semiconductor Components Industries, LLC dba ON Semiconductor or its subsidiaries in the United States and/or other countries. ON Semiconductor reserves the right to make changes without further notice to any products herein. ON Semiconductor makes no warranty, representation or guarantee regarding the suitability of its products for any particular purpose, nor does ON Semiconductor assume any liability arising out of the application or use of any product or circuit, and specifically disclaims any and all liability, including without limitation special, consequential or incidental damages. ON Semiconductor does not convey any license under its patent rights nor the rights of others.

MECHANICAL CASE OUTLINE PACKAGE DIMENSIONS

ON Semiconductor®



SCALE 1:1

SOIC-16 CASE 751B-05 ISSUE K

DATE 29 DEC 2006



NOTES:

1. DIMENSIONING AND TOLERANCING PER ANSI Y14.5M, 1982.
2. CONTROLLING DIMENSION: MILLIMETER.
3. DIMENSIONS A AND B DO NOT INCLUDE MOLD PROTRUSION.
4. MAXIMUM MOLD PROTRUSION 0.15 (0.006) PER SIDE.
5. DIMENSION D DOES NOT INCLUDE DAMBAR PROTRUSION. ALLOWABLE DAMBAR PROTRUSION SHALL BE 0.127 (0.005) TOTAL IN EXCESS OF THE D DIMENSION AT MAXIMUM MATERIAL CONDITION.

DIM	MILLIMETERS		INCHES	
	MIN	MAX	MIN	MAX
A	9.80	10.00	0.386	0.393
B	3.80	4.00	0.150	0.157
C	1.35	1.75	0.054	0.068
D	0.35	0.49	0.014	0.019
F	0.40	1.25	0.016	0.049
G	1.27 BSC		0.050 BSC	
J	0.19	0.25	0.008	0.009
K	0.10	0.25	0.004	0.009
M	0°	7°	0°	7°
P	5.80	6.20	0.229	0.244
R	0.25	0.50	0.010	0.019

- | | | | |
|--|--|--|--|
| <p>STYLE 1:</p> <p>PIN 1. COLLECTOR</p> <p>2. BASE</p> <p>3. EMITTER</p> <p>4. NO CONNECTION</p> <p>5. EMITTER</p> <p>6. BASE</p> <p>7. COLLECTOR</p> <p>8. COLLECTOR</p> <p>9. BASE</p> <p>10. EMITTER</p> <p>11. NO CONNECTION</p> <p>12. EMITTER</p> <p>13. BASE</p> <p>14. COLLECTOR</p> <p>15. EMITTER</p> <p>16. COLLECTOR</p> | <p>STYLE 2:</p> <p>PIN 1. CATHODE</p> <p>2. ANODE</p> <p>3. NO CONNECTION</p> <p>4. CATHODE</p> <p>5. CATHODE</p> <p>6. NO CONNECTION</p> <p>7. ANODE</p> <p>8. CATHODE</p> <p>9. CATHODE</p> <p>10. ANODE</p> <p>11. NO CONNECTION</p> <p>12. CATHODE</p> <p>13. CATHODE</p> <p>14. NO CONNECTION</p> <p>15. ANODE</p> <p>16. CATHODE</p> | <p>STYLE 3:</p> <p>PIN 1. COLLECTOR, DYE #1</p> <p>2. BASE, #1</p> <p>3. EMITTER, #1</p> <p>4. COLLECTOR, #1</p> <p>5. COLLECTOR, #2</p> <p>6. BASE, #2</p> <p>7. EMITTER, #2</p> <p>8. COLLECTOR, #2</p> <p>9. COLLECTOR, #3</p> <p>10. BASE, #3</p> <p>11. EMITTER, #3</p> <p>12. COLLECTOR, #3</p> <p>13. COLLECTOR, #4</p> <p>14. BASE, #4</p> <p>15. EMITTER, #4</p> <p>16. COLLECTOR, #4</p> | <p>STYLE 4:</p> <p>PIN 1. COLLECTOR, DYE #1</p> <p>2. COLLECTOR, #1</p> <p>3. COLLECTOR, #2</p> <p>4. COLLECTOR, #2</p> <p>5. COLLECTOR, #3</p> <p>6. COLLECTOR, #3</p> <p>7. COLLECTOR, #4</p> <p>8. COLLECTOR, #4</p> <p>9. BASE, #4</p> <p>10. EMITTER, #4</p> <p>11. BASE, #3</p> <p>12. EMITTER, #3</p> <p>13. BASE, #2</p> <p>14. EMITTER, #2</p> <p>15. BASE, #1</p> <p>16. EMITTER, #1</p> |
| <p>STYLE 5:</p> <p>PIN 1. DRAIN, DYE #1</p> <p>2. DRAIN, #1</p> <p>3. DRAIN, #2</p> <p>4. DRAIN, #2</p> <p>5. DRAIN, #3</p> <p>6. DRAIN, #3</p> <p>7. DRAIN, #4</p> <p>8. DRAIN, #4</p> <p>9. GATE, #4</p> <p>10. SOURCE, #4</p> <p>11. GATE, #3</p> <p>12. SOURCE, #3</p> <p>13. GATE, #2</p> <p>14. SOURCE, #2</p> <p>15. GATE, #1</p> <p>16. SOURCE, #1</p> | <p>STYLE 6:</p> <p>PIN 1. CATHODE</p> <p>2. CATHODE</p> <p>3. CATHODE</p> <p>4. CATHODE</p> <p>5. CATHODE</p> <p>6. CATHODE</p> <p>7. CATHODE</p> <p>8. CATHODE</p> <p>9. ANODE</p> <p>10. ANODE</p> <p>11. ANODE</p> <p>12. ANODE</p> <p>13. ANODE</p> <p>14. ANODE</p> <p>15. ANODE</p> <p>16. ANODE</p> | <p>STYLE 7:</p> <p>PIN 1. SOURCE N-CH</p> <p>2. COMMON DRAIN (OUTPUT)</p> <p>3. COMMON DRAIN (OUTPUT)</p> <p>4. GATE P-CH</p> <p>5. COMMON DRAIN (OUTPUT)</p> <p>6. COMMON DRAIN (OUTPUT)</p> <p>7. COMMON DRAIN (OUTPUT)</p> <p>8. SOURCE P-CH</p> <p>9. SOURCE P-CH</p> <p>10. COMMON DRAIN (OUTPUT)</p> <p>11. COMMON DRAIN (OUTPUT)</p> <p>12. COMMON DRAIN (OUTPUT)</p> <p>13. GATE N-CH</p> <p>14. COMMON DRAIN (OUTPUT)</p> <p>15. COMMON DRAIN (OUTPUT)</p> <p>16. SOURCE N-CH</p> | |

SOLDERING FOOTPRINT



DIMENSIONS: MILLIMETERS

DOCUMENT NUMBER:	98ASB42566B	Electronic versions are uncontrolled except when accessed directly from the Document Repository. Printed versions are uncontrolled except when stamped "CONTROLLED COPY" in red.
DESCRIPTION:	SOIC-16	PAGE 1 OF 1

ON Semiconductor and ON are trademarks of Semiconductor Components Industries, LLC dba ON Semiconductor or its subsidiaries in the United States and/or other countries. ON Semiconductor reserves the right to make changes without further notice to any products herein. ON Semiconductor makes no warranty, representation or guarantee regarding the suitability of its products for any particular purpose, nor does ON Semiconductor assume any liability arising out of the application or use of any product or circuit, and specifically disclaims any and all liability, including without limitation special, consequential or incidental damages. ON Semiconductor does not convey any license under its patent rights nor the rights of others.

MECHANICAL CASE OUTLINE

PACKAGE DIMENSIONS

ON Semiconductor®



TSSOP-16
CASE 948F-01
ISSUE B

DATE 19 OCT 2006



NOTES:

1. DIMENSIONING AND TOLERANCING PER ANSI Y14.5M, 1982.
2. CONTROLLING DIMENSION: MILLIMETER.
3. DIMENSION A DOES NOT INCLUDE MOLD FLASH. PROTRUSIONS OR GATE BURRS. MOLD FLASH OR GATE BURRS SHALL NOT EXCEED 0.15 (0.006) PER SIDE.
4. DIMENSION B DOES NOT INCLUDE INTERLEAD FLASH OR PROTRUSION. INTERLEAD FLASH OR PROTRUSION SHALL NOT EXCEED 0.25 (0.010) PER SIDE.
5. DIMENSION K DOES NOT INCLUDE DAMBAR PROTRUSION. ALLOWABLE DAMBAR PROTRUSION SHALL BE 0.08 (0.003) TOTAL IN EXCESS OF THE K DIMENSION AT MAXIMUM MATERIAL CONDITION.
6. TERMINAL NUMBERS ARE SHOWN FOR REFERENCE ONLY.
7. DIMENSION A AND B ARE TO BE DETERMINED AT DATUM PLANE -W-.

DIM	MILLIMETERS		INCHES	
	MIN	MAX	MIN	MAX
A	4.90	5.10	0.193	0.200
B	4.30	4.50	0.169	0.177
C	---	1.20	---	0.047
D	0.05	0.15	0.002	0.006
F	0.50	0.75	0.020	0.030
G	0.65 BSC		0.026 BSC	
H	0.18	0.28	0.007	0.011
J	0.09	0.20	0.004	0.008
J1	0.09	0.16	0.004	0.006
K	0.19	0.30	0.007	0.012
K1	0.19	0.25	0.007	0.010
L	6.40 BSC		0.252 BSC	
M	0°	8°	0°	8°

SOLDERING FOOTPRINT



GENERIC MARKING DIAGRAM*



- XXXX = Specific Device Code
- A = Assembly Location
- L = Wafer Lot
- Y = Year
- W = Work Week
- G or ■ = Pb-Free Package

*This information is generic. Please refer to device data sheet for actual part marking. Pb-Free indicator, "G" or microdot "■", may or may not be present.

DOCUMENT NUMBER:	98ASH70247A	Electronic versions are uncontrolled except when accessed directly from the Document Repository. Printed versions are uncontrolled except when stamped "CONTROLLED COPY" in red.
DESCRIPTION:	TSSOP-16	PAGE 1 OF 1

ON Semiconductor and ON are trademarks of Semiconductor Components Industries, LLC dba ON Semiconductor or its subsidiaries in the United States and/or other countries. ON Semiconductor reserves the right to make changes without further notice to any products herein. ON Semiconductor makes no warranty, representation or guarantee regarding the suitability of its products for any particular purpose, nor does ON Semiconductor assume any liability arising out of the application or use of any product or circuit, and specifically disclaims any and all liability, including without limitation special, consequential or incidental damages. ON Semiconductor does not convey any license under its patent rights nor the rights of others.